

LSE

Atmospheres containing explosive GAS



totally enclosed three-phase asynchronous motors

**CATEGORY 2
ZONE 1**

General information



Increased safety, totally enclosed three-phase asynchronous motors, LSE series, according to IEC 60034, 60072, IEC 60079-0 and 60079-7.

- Single speed: power 0.25 to 37 kW¹, frame size 63 to 250 mm, 2, 4 and 6 poles; 230/400 V or 400 V Δ, 50 Hz.
- Two speed: on request.

Protection IP 55
(or IP 65 if GD application).

- Motors for variable speed operation:**
- fitted with thermal probes in winding (obligatory) and bearing probes for frame size ≥ 160 mm.
 - on consultation (for selection).

Finish: aluminium casing

- Assembled with protected screws.
- RAL 2004 (orange)** finishing paint
- Protection of flange and shaft end against atmospheric corrosion.
- Individual anti-shock packaging.
- Motors in accordance with the VIK recommendations (option).

Mains supply

- Standard construction according to IEC 60038:
- 230/400 V +10% -10% at 50 Hz ;
- 400 V Δ +10% -10% at 50 Hz.

1. Other powers: consult us.

Motors in accordance with the European Directive 94/9/CE.



**II 2G Ex e IIT3
(Ex tD A21 T125)**

Description of the LSE three-phase motors

Component	Materials	Remarks
Finned housing	Aluminium alloy	- with bolt-on or cast foot, or without foot <ul style="list-style-type: none"> • 4 or 6 mounting holes for the foot housings • lifting rings for frame size ≥ 132 M, in option for 132 S and 112 - earth terminal optional
Stator	Insulated low carbon magnetic steel laminations Enameled electrolytic copper	- the low carbon content guarantees long term stability of the characteristics - assembled laminated pack - semi-enclosed slots - insulation system class F
Rotor	Insulated low carbon magnetic steel laminations Aluminium	- inclined slots - squirrel cage pressure die cast in aluminium (or alloy for special applications) - mounted on shaft by heat shrinking or keying on the shaft - dynamically balanced rotor class A - 1/2 key
Shaft	Steel	- for frame size < 132: <ul style="list-style-type: none"> • centre holes fitted with a screw and a shaft end washer • closed keyway - for frame size ≥ 132: <ul style="list-style-type: none"> • tapped centre hole • open key
End shields	Aluminium alloy	- frame size 63 - 71 front and rear - frame size 80 - 90 rear
	Cast iron	- frame size 80 - 90 front (optional for 80 and 90 rear) - frame size ≥ 100
Bearings and lubrication		- ball bearings - reverse preloaded bearings
Labyrinth seals Lipseals	Technopolymer or steel Synthetic rubber	- sealing by lipseals - front or rear jet deflector or labyrinth seals
Fan	Composite or aluminium alloy	- 2 directions of rotation: straight blades
Fan cover	Sheet steel	- on request, fitted with a drip cover for operation in vertical position, shaft facing down
Terminal box	Aluminium alloy	- IP 55 or IP 65 for "GD" application - rotatable, opposite to the position of foot - fitted with a 6 stud safety certified terminal board Ex e - delivered fitted with Ex e safety certified cable glands - 1 staple earth terminal in all terminal boxes

LSE



Atmospheres containing explosive GAS totally enclosed three-phase asynchronous motors

**CATEGORY 2
ZONE 1**

Mounting positions

A

Foot mounted motors

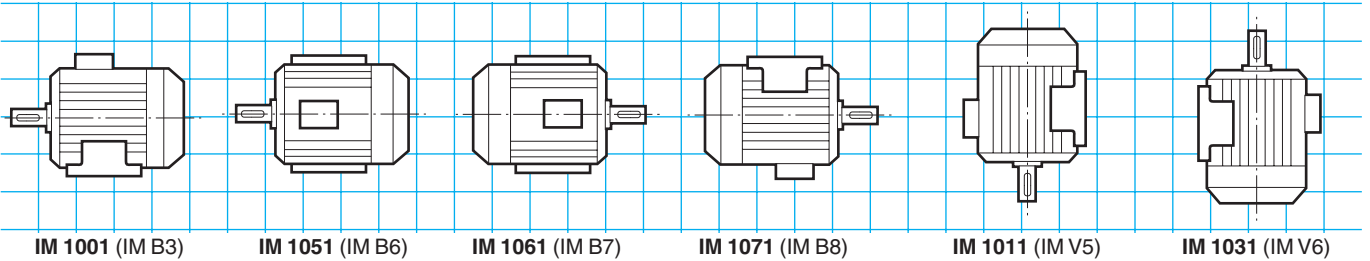

(FF) plain hole flange mounted motors

• Possible position IM 3001 (IM B5) up to 225 frame size inclusive

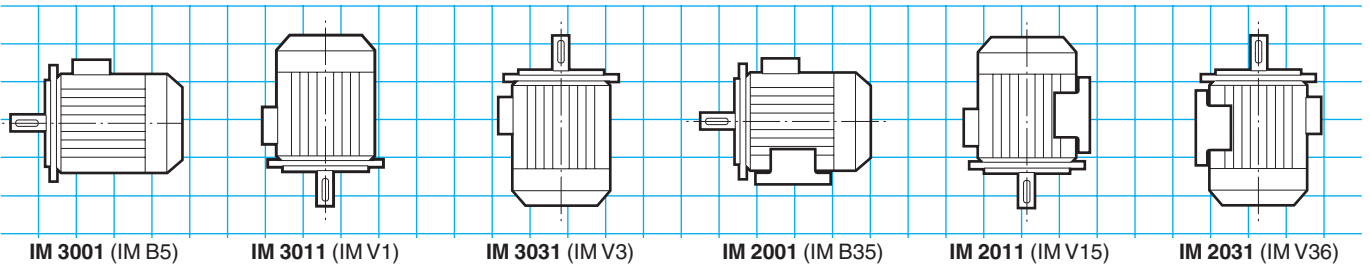

(FT) tapped hole flange mounted motors

• Possible position up to 132 frame size inclusive

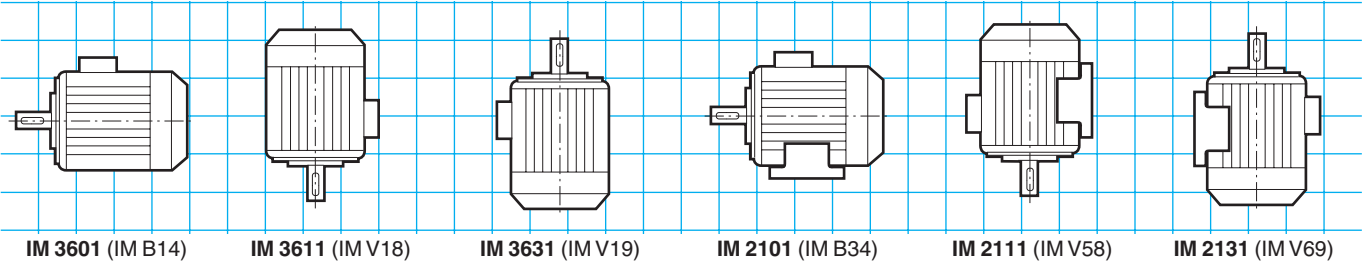

Terminal box position in relation to the motor shaft end

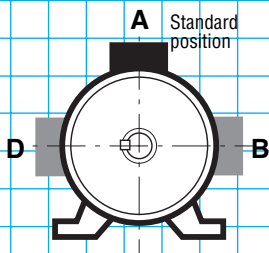

A : standard

Cable gland position in relation to the motor shaft end

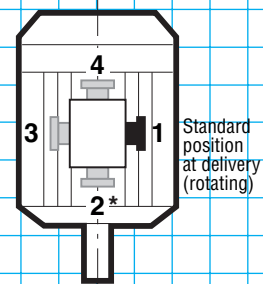

1: standard

* Position 2 not recommended and not feasible
plain hole flange standard mounted motors (FF)

LSE

Atmospheres containing explosive GAS



totally enclosed three-phase asynchronous motors

Selection

**CATEGORY 2
ZONE 1**

IP 55 - 50 Hz - Class F - ΔT 80 K - 400 V - S1

II - 2G - Ex e II T3

**2
poles
3000 min⁻¹**

Type	Rated power P_N kW	Rated speed N_N min-1	Rated moment M_N Nm	Rated current $I_{N(400V)}$ A	Power factor $\cos \Phi$ 100 %	Efficiency IEC 60034-2; 1996 η 100 %	Starting torque/ Rated torque I_d / I_n	Weight IM B3 kg
LSE 80 L	0.75	2872	2.5	1.6	0.84	79.4	7.1	9.7
LSE 80 L	1.1	2870	3.75	2.3	0.86	78.5	7.5	11.3
LSE 90 S	1.5	2860	5	2.9	0.88	83.6	7.5	14
LSE 90 L	2.2	2884	7.5	4.2	0.87	85.7	6.7	17.8
LSE 100 L	3	2887	10.1	5.6	0.89	86.2	5.5	24
LSE 112 MU	4	2928	13.5	7.1	0.92	88.6	7.5	39
LSE 132 SM	5.5	2926	18.6	9.7	0.91	89.8	6.5	49
LSE 132 SM	7.5	2929	25.4	13.1	0.92	90.4	6.9	54
LSE 160 MP	11	2935	36	19.1	0.92	90.5	7.1	72
LSE 160 L	15	2933	48.8	26.7	0.89	91	7.8	88
LSE 180 MT	18.5	2930	60.3	32.5	0.9	91.3	7.8	99
LSE 200 LT	22	2946	71.3	36.8	0.92	93.7	8.5	154
LSE 200 L	30	2956	96.9	50.9	0.91	93.5	7.8	180
LSE 225 MT	37	2951	120	62.7	0.91	93.6	7.8	200

IP 55 - 50 Hz - Class F - ΔT 80 K - 400 V - S1

II - 2G - Ex e II T3 VIK

**2
poles
3000 min⁻¹**

Type	Rated power P_N kW	Rated speed N_N min-1	Rated moment M_N Nm	Rated current $I_{N(400V)}$ A	Power factor $\cos \Phi$ 100 %	Efficiency IEC 60034-2; 1996 η 100 %	Starting torque/ Rated torque I_d / I_n	Weight IM B3 kg
LSE 90 S	1.5	2865	5	3	0.87	82.8	7.5	14
LSE 90 L	1.85	2890	6.3	3.6	0.86	86.2	6.5	17.8
LSE 100 L	2.5	2865	8.5	4.8	0.89	94.7	5.8	22
LSE 112 MG	3.3	2925	11.2	6.3	0.93	82.4	9.2	35
LSE 132 SM	4.6	2932	15.6	8.2	0.9	90	6.8	49
LSE 132 SM	5.5	2940	18.6	9.9	0.89	90	7.2	54
LSE 160 MP	7.5	2940	25.4	13	0.91	91	7.3	72
LSE 160 MP	10	2937	34	17.5	0.92	91	7.5	72
LSE 160 L	12.5	2950	40.5	22.4	0.88	91.6	9.3	88
LSE 180 MT	15	2950	48.6	26.5	0.89	91.9	9.3	99
LSE 200 LT	20	2954	64.7	33.5	0.92	93.7	9.2	154
LSE 200 L	24	2968	77.2	41	0.9	93.8	9.3	180
LSE 225 MT	28	2964	90.2	47.4	0.91	93.7	9.3	200

LSE

Atmospheres containing explosive GAS



totally enclosed three-phase asynchronous motors

Selection

**CATEGORY 2
ZONE 1**

IP 55 - 50 Hz - Class F - ΔT 80 K - 400 V - S1

II - 2G - Ex e II T3

**2
poles
3000 min⁻¹**

A

Type	Rated power at 50 Hz P_N kW	IM 1001 (IM B3)		IM 3001 (IM B5)	
		Code	Qty	Code	Qty
LSE 80 L	0.75	-	-	-	-
LSE 80 L	1.1	-	-	-	-
LSE 90 S	1.5	-	-	-	-
LSE 90 L	2.2	-	-	-	-
LSE 100 L	3	-	-	-	-
LSE 112 MU	4	-	-	-	-
LSE 132 SM	5.5	-	-	-	-
LSE 132 SM	7.5	-	-	-	-
LSE 160 MP	11	-	-	-	-
LSE 160 L	15	-	-	-	-
LSE 180 MT	18.5	-	-	-	-
LSE 200 LT	22	-	-	-	-
LSE 200 L	30	-	-	-	-
LSE 225 MT	37	-	-	-	-

IP 55 - 50 Hz - Class F - ΔT 80 K - 400 V - S1

II - 2G - Ex e II T3 VIK

**2
poles
3000 min⁻¹**

Type	Rated power at 50 Hz P_N kW	IM 1001 (IM B3)		IM 3001 (IM B5)	
		Code	Qty	Code	Qty
LSE 90 S	1.5	-	-	-	-
LSE 90 L	1.85	-	-	-	-
LSE 100 L	2.5	-	-	-	-
LSE 112 MG	3.3	-	-	-	-
LSE 132 SM	4.6	-	-	-	-
LSE 132 SM	5.5	-	-	-	-
LSE 160 MP	7.5	-	-	-	-
LSE 160 MP	10	-	-	-	-
LSE 160 L	12.5	-	-	-	-
LSE 180 MT	15	-	-	-	-
LSE 200 LT	20	-	-	-	-
LSE 200 L	24	-	-	-	-
LSE 225 MT	28	-	-	-	-

LSE

Atmospheres containing explosive GAS



totally enclosed three-phase asynchronous motors

Selection

**CATEGORY 2
ZONE 1**

IP 55 - 50 Hz - Class F - ΔT 80 K - 400 V - S1

II - 2G - Ex e II T3

**4
poles
1500 min⁻¹**

Type	Rated power P_N kW	Rated speed N_N min-1	Rated moment M_N Nm	Rated current $I_{N(400V)}$ A	Power factor $\cos \Phi$ 100 %	Efficiency IEC 60034-2; 1996 η 100 %	Starting torque/ Rated torque I_d / I_n	Weight IM B3 kg
LSE 80 L	0.75	1430	5	2	0.72	74	5.6	10.9
LSE 90 S	1.1	1443	7.5	2.4	0.83	81.5	5.2	13.5
LSE 90 L	1.5	1450	10	3.7	0.75	78	6.4	15.2
LSE 100 L	2.2	1444	15	4.5	0.85	83.5	5.8	22.5
LSE 100 LR	3	1423	20	6.2	0.85	83	5.2	27.5
LSE 112 MU	4	1458	27.2	7.7	0.86	86.9	6.7	36.5
LSE 132 SM	5.5	1464	37.4	10.3	0.87	88.4	6.5	54.7
LSE 132 M	7.5	1457	50	14.8	0.85	86	8.4	59.9
LSE 160 MR	11	1468	74.7	22	0.82	89	8.1	78
LSE 160 L	15	1455	98.5	28	0.86	89.8	7.3	100
LSE 180 MR	18.5	1458	121	34	0.86	91.2	7.9	112
LSE 180 LU	22	1464	144	39.7	0.87	91.9	7.1	165
LSE 200 L	30	1472	195	54.8	0.85	93	6.6	205
LSE 225 SR	37	1471	240	68.2	0.84	93.2	6.6	235

IP 55 - 50 Hz - Class F - ΔT 80 K - 400 V - S1

II - 2G - Ex e II T3 VIK

**4
poles
1500 min⁻¹**

Type	Rated power P_N kW	Rated speed N_N min-1	Rated moment M_N Nm	Rated current $I_{N(400V)}$ A	Power factor $\cos \Phi$ 100 %	Efficiency IEC 60034-2; 1996 η 100 %	Starting torque/ Rated torque I_d / I_n	Weight IM B3 kg
LSE 90 S	1	1450	6.8	2.3	0.81	81.7	5.8	13.5
LSE 90 L	1.35	1450	9.2	2.9	0.81	83.5	6.6	15.2
LSE 100 L	1.85	1451	12.6	4	0.78	84	7	22.5
LSE 100 L	2.5	1436	16.9	5.6	0.79	81.2	5.8	24.9
LSE 112 MU	3.6	1455	24.4	7.1	0.84	86.4	7.1	36.5
LSE 132 SM	5	1456	33.9	9.7	0.87	85.5	8.5	54.7
LSE 132 M	6.8	1457	46.2	13	0.88	84.9	7.9	59.9
LSE 160 MR	10	1469	67.9	20.5	0.81	88	9.5	78
LSE 160 L	13.5	1461	88.2	25.4	0.85	90.4	7.8	100
LSE 180 MR	15	1469	97.5	28.4	0.83	91.8	9.4	112
LSE 180 LU	17.5	1475	113	32.5	0.84	92.4	8.6	165
LSE 200 L	24	1481	155	44.6	0.83	93.6	8	205
LSE 225 SR	30	1479	194	57.1	0.81	93.6	7.9	235
LSE 225 MR	36	1471	234	66.3	0.84	93.3	6.8	235

LSE

Atmospheres containing explosive GAS



totally enclosed three-phase asynchronous motors

Selection

**CATEGORY 2
ZONE 1**

IP 55 - 50 Hz - Class F - ΔT 80 K - 400 V - S1

II - 2G - Ex e II T3

A

**4
poles
1500 min⁻¹**

Type	Rated power at 50 Hz P_N kW	IM 1001 (IM B3)		IM 3001 (IM B5)	
		Code	Qty	Code	Qty
LSE 80 L	0.75		-		-
LSE 90 S	1.1		-		-
LSE 90 L	1.5		-		-
LSE 100 L	2.2		-		-
LSE 100 LR	3		-		-
LSE 112 MU	4		-		-
LSE 132 SM	5.5		-		-
LSE 132 M	7.5		-		-
LSE 160 MR	11		-		-
LSE 160 L	15		-		-
LSE 180 MR	18.5		-		-
LSE 180 LU	22		-		-
LSE 200 L	30		-		-
LSE 225 SR	37		-		-

IP 55 - 50 Hz - Class F - ΔT 80 K - 400 V - S1

II - 2G - Ex e II T3 VIK

**4
poles
1500 min⁻¹**

Type	Rated power at 50 Hz P_N kW	IM 1001 (IM B3)		IM 3001 (IM B5)	
		Code	Qty	Code	Qty
LSE 90 S	1		-		-
LSE 90 L	1.35		-		-
LSE 100 L	1.85		-		-
LSE 100 L	2.5		-		-
LSE 112 MU	3.6		-		-
LSE 132 SM	5		-		-
LSE 132 M	6.8		-		-
LSE 160 MR	10		-		-
LSE 160 L	13.5		-		-
LSE 180 MR	15		-		-
LSE 180 LU	17.5		-		-
LSE 200 L	24		-		-
LSE 225 SR	30		-		-
LSE 225 MR	36		-		-

LSE

Atmospheres containing explosive GAS



totally enclosed three-phase asynchronous motors

Selection

**CATEGORY 2
ZONE 1**

IP 55 - 50 Hz - Class F - ΔT 80 K - 400 V - S1

II - 2G - Ex e II T3

**6
poles
1000 min⁻¹**

A

Type	Rated power P_N kW	Rated speed N_N min-1	Rated moment M_N Nm	Rated current $I_{N(400V)}$ A	Power factor $\cos \Phi$ 100 %	Efficiency IEC 60034-2; 1996 η 100 %	Starting torque/ Rated torque I_d / I_n	Weight IM B3 kg
LSE 80 L	0.37	948	3.7	1.2	0.68	65.3	3.7	9.7
LSE 80 L	0.55	955	5.5	1.8	0.64	68.6	4.5	11
LSE 90 S	0.75	935	7.5	2.2	0.67	75	4.6	13.5
LSE 90 L	1.1	918	11	3	0.72	75.2	4.1	15.2
LSE 100 L	1.5	928	15	4.2	0.67	76.8	4.6	19.7
LSE 112 MG	2.2	938	22	5.4	0.74	80.1	4.3	33
LSE 132 SM	3	963	30	7	0.74	84.6	4.3	43.4
LSE 132 M	4	966	40	9.1	0.74	85.9	4.6	59.4
LSE 132 MU	5.5	963	55	12.3	0.75	86.4	4.7	66.5
LSE 160 M	7.5	965	74.2	15.9	0.79	86	5	81
LSE 160 L	11	963	109	23.6	0.78	86.2	5.1	105
LSE 180 L	15	965	148	30.1	0.82	87.8	5.6	135
LSE 200 LT	18.5	969	182	38	0.79	89	6.2	160
LSE 200 L	22	974	216	44.1	0.8	90.1	6.2	190
LSE 225 MR	30	976	294	61.9	0.77	90.8	6.7	235

IP 55 - 50 Hz - Class F - ΔT 80 K - 400 V - S1

II - 2G - Ex e II T3 VIK

**6
poles
1000 min⁻¹**

Type	Rated power P_N kW	Rated speed N_N min-1	Rated moment M_N Nm	Rated current $I_{N(400V)}$ A	Power factor $\cos \Phi$ 100 %	Efficiency IEC 60034-2; 1996 η 100 %	Starting torque/ Rated torque I_d / I_n	Weight IM B3 kg
LSE 90 S	0.65	937	6.5	1.8	0.68	75	4.7	13.5
LSE 90 L	0.95	920	9.5	2.5	0.73	75.4	4.2	15.2
LSE 100 L	1.3	930	13	3.5	0.68	76.9	4.3	19.7
LSE 112 MG	1.9	937	19	4.7	0.73	79.7	4.2	33
LSE 132 SM	2.6	964	26	6	0.73	84.7	4	43.4
LSE 132 M	3.5	967	35	8	0.74	85.6	4.5	59.4
LSE 132 MU	4.8	967	48	10.8	0.74	86.8	5	66.5
LSE 160 M	6.6	972	64.8	14.5	0.76	86.6	5.5	81
LSE 160 L	9.7	970	95.5	21.5	0.75	86.9	5.7	105
LSE 180 L	13.2	972	130	26.8	0.8	88.9	6.3	135
LSE 200 LT	16.5	974	162	34.6	0.77	89.5	6.8	160
LSE 200 L	20	977	196	40.4	0.79	90.5	6.8	190
LSE 225 MR	27	979	263	57	0.75	91	7.2	235

LSE

Atmospheres containing explosive GAS



totally enclosed three-phase asynchronous motors

Selection

**CATEGORY 2
ZONE 1**

IP 55 - 50 Hz - Class F - ΔT 80 K - 400 V - S1

II - 2G - Ex e II T3

**6
poles
1000 min⁻¹**

A

Type	Rated power at 50 Hz P_N kW	IM 1001 (IM B3)		IM 3001 (IM B5)	
		Code	Qty	Code	Qty
LSE 80 L	0.37	-	-	-	-
LSE 80 L	0.55	-	-	-	-
LSE 90 S	0.75	-	-	-	-
LSE 90 L	1.1	-	-	-	-
LSE 100 L	1.5	-	-	-	-
LSE 112 MG	2.2	-	-	-	-
LSE 132 SM	3	-	-	-	-
LSE 132 M	4	-	-	-	-
LSE 132 MU	5.5	-	-	-	-
LSE 160 M	7.5	-	-	-	-
LSE 160 L	11	-	-	-	-
LSE 180 L	15	-	-	-	-
LSE 200 LT	18.5	-	-	-	-
LSE 200 L	22	-	-	-	-
LSE 225 MR	30	-	-	-	-

IP 55 - 50 Hz - Class F - ΔT 80 K - 400 V - S1

II - 2G - Ex e II T3 VIK

**6
poles
1000 min⁻¹**

Type	Rated power at 50 Hz P_N kW	IM 1001 (IM B3)		IM 3001 (IM B5)	
		Code	Qty	Code	Qty
LSE 90 S	0.65	-	-	-	-
LSE 90 L	0.95	-	-	-	-
LSE 100 L	1.3	-	-	-	-
LSE 112 MG	1.9	-	-	-	-
LSE 132 SM	2.6	-	-	-	-
LSE 132 M	3.5	-	-	-	-
LSE 132 MU	4.8	-	-	-	-
LSE 160 M	6.6	-	-	-	-
LSE 160 L	9.7	-	-	-	-
LSE 180 L	13.2	-	-	-	-
LSE 200 LT	16.5	-	-	-	-
LSE 200 L	20	-	-	-	-
LSE 225 MR	27	-	-	-	-



LSE

Atmospheres containing explosive GAS

totally enclosed three-phase asynchronous motors

CATEGORY 2
ZONE 1

Dimensions

Dimensions of the LSE totally enclosed three-phase asynchronous motors - IP 55
Cage rotor

Dimensions in millimetres

- shaft end

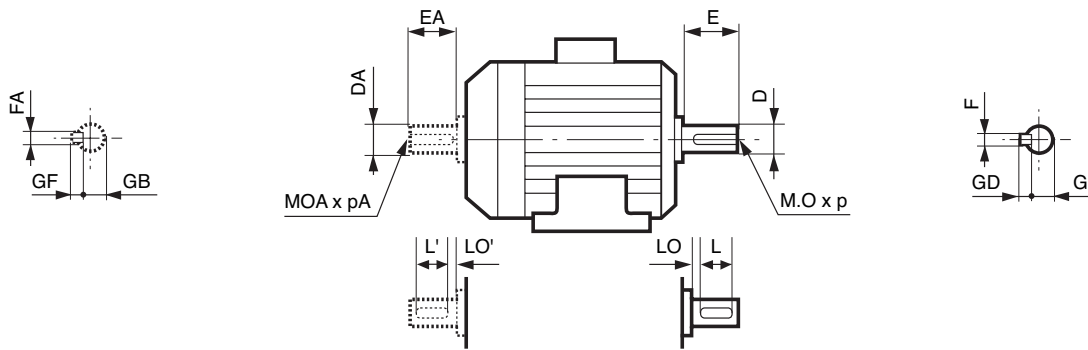

Type	Main shaft end																	
	4 and 6 poles									2 poles								
	F	GD	D	G	E	O	p	L	LO	F	GD	D	G	E	O	p	L	LO
LSE 80 L	6	6	19j6	15.5	40	6	16	30	6	6	6	19j6	15.5	40	6	16	30	6
LSE 90 S/L	8	7	24j6	20	50	8	19	40	6	8	7	24j6	20	50	8	19	40	6
LSE 100 L	8	7	28j6	24	60	10	22	50	6	8	7	28j6	24	60	10	22	50	6
LSE112 MG/MU	8	7	28j6	24	60	10	22	50	6	8	7	28j6	24	60	10	22	50	6
LSE 132 S/M/SM	10	8	38k6	33	80	12	28	63	10	10	8	38k6	33	80	12	28	63	10
LSE 160 M/L/MP/LU/MR	12	8	42k6	37	110	16	36	100	6	12	8	42k6	37	110	16	36	100	6
LSE 180 MT/L/LU/MR	14	8	48k6	42.5	110	16	36	98	12	14	9	48k6	42.5	110	16	36	98	12
LSE 200 LT/L	16	10	55m6	49	110	20	42	97	13	16	10	55m6	49	110	20	42	97	13
LSE 225 ST/MR/SR/MT	18	11	60m6	53	140	20	42	126	14	16	10	55m6	49	110	20	42	97	13

Type	Secondary shaft end																	
	4 and 6 poles									2 poles								
	FA	GF	DA	GB	EA	OA	pA	L'	LO'	FA	GF	DA	GB	EA	OA	pA	L'	LO'
LSE 80 L	5	5	14j6	11	30	5	15	25	3.5	5	5	14j6	11	30	5	15	25	3.5
LSE 90 S/L	6	6	19j6	15.5	40	6	16	30	6	6	6	19j6	15.5	40	6	16	30	6
LSE 100 L	8	7	24j6	20	50	8	19	40	6	8	7	24j6	20	50	8	19	40	6
LSE 112 MG/MU	8	7	24j6	20	50	8	19	40	6	8	7	24j6	20	50	8	19	40	6
LSE 132 S/M	8	7	28j6	24	60	10	22	50	6	8	7	28j6	24	60	10	22	50	6
LSE 160 MP/MR	10	8	38k6	33	80	12	28	63	10	10	8	38k6	33	80	12	28	63	10
LSE 160 M/L	12	8	42k6	37	110	16	36	100	6	12	8	42k6	37	110	16	36	100	6
LSE 180 MT/L/LU/MR	14	9	48k6	42.5	110	16	36	98	12	14	9	48k6	42.5	110	16	36	98	12
LSE 200 LT/L	16	10	55m6	49	110	20	42	97	13	16	10	55m6	49	110	20	42	97	13
LSE 225 ST/MR/SR/MT	18	11	60m6	53	140	20	42	126	14	16	10	55m6	49	110	20	42	97	13

LSE

Atmospheres containing explosive GAS



totally enclosed three-phase asynchronous motors

**CATEGORY 2
ZONE 1**

Dimensions

Dimensions of the LSE totally enclosed three-phase asynchronous motors - IP 55
Cage rotor

Dimensions in millimetres

– foot mounted

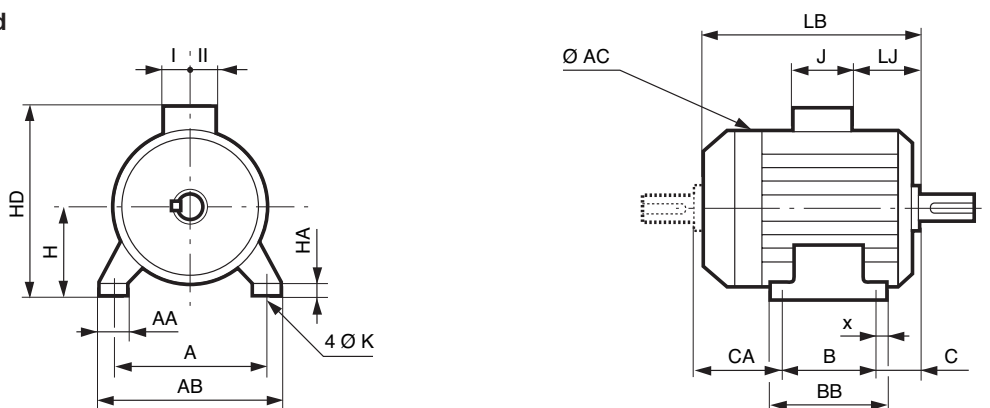

Type	Main dimensions																	
	A	AB	B	BB	C	x	AA	K	HA	H	AC	HD	LB	LJ	J	I	II	CA
LSE 80 L	125	157	100	120	50	10	29	9	10	80	170	226	215	13.5	160	55	55	68
LSE 90 S	140	172	100	120	56	10	37	10	11	90	190	246	218	13.5	160	55	55	66
LSE 90 L	140	172	125	162	56	28	37	10	11	90	190	246	245	13.5	160	55	55	68
LSE 100 L	160	196	140	165	63	12	40	12	13	100	200	261	290	14	160	55	55	93
LSE 100 LR	160	196	140	165	63	12	40	12	13	100	200	261	290	14	160	55	55	93
LSE 100 LG	160	196	140	165	63	12	40	12	13	100	200	261	290	14	160	55	55	93
LSE 112 MU	190	220	140	165	70	12	52	12	14	112	235	267	334	41	160	55	55	130
LSE 112 MG	190	220	140	165	70	12	52	12	14	112	235	276	315	24	160	55	55	110
LSE 132 SM	216	250	178	208	89	16	59	12	18	132	280	307	387	25	160	55	55	126
LSE 132 M	216	250	178	208	89	16	59	12	18	132	280	307	387	25	160	55	55	126
LSE 132 MU	216	250	178	208	89	16	59	12	18	132	280	307	410	25	160	55	55	148
LSE 160 MP	254	294	210	294	108	20	64	14.5	25	160	280	368	468	55.5	160	55	55	154
LSE 160 L	254	294	254	294	108	20	60	14.5	25	160	310	395	495	44	134	92	63	138
LSE 160 MR	254	294	254	294	108	20	64	14.5	25	160	315	357	495	55.5	160	55	55	138
LSE 160 M	254	294	210	294	108	20	60	14.5	25	160	310	395	495	44	134	92	63	182
LSE 180 MT	279	324	241	316	121	20	79	14.5	28	180	316	428	495	45	205	100	95	138
LSE 180 MR	279	324	241	316	121	20	79	14.5	28	180	316	428	520	45	205	100	95	163
LSE 180 LU	279	339	279	329	121	25	86	14.5	25	180	350	435	593	54	205	100	95	199
LSE 180 L	279	339	279	329	121	25	86	14.5	25	180	350	435	552	54	205	100	95	159
LSE 200 LT	318	378	305	365	133	30	108	18.5	32	200	350	455	599	60	205	100	95	167
LSE 200 L	318	388	305	375	133	35	103	18.5	36	200	390	475	621	68	205	100	95	194
LSE 225 MT	356	431	311	386	149	50	127	18.5	36	225	390	500	627	74	205	100	95	203
LSE 225 SR	356	431	286	386	149	50	127	18.5	36	225	390	500	676	74	205	100	95	253
LSE 225 MR	356	431	311	386	149	50	127	18.5	36	225	390	500	676	74	205	100	95	228

LSE



Atmospheres containing explosive GAS totally enclosed three-phase asynchronous motors

**CATEGORY 2
ZONE 1**

Dimensions

Dimensions of the LSE totally enclosed three-phase asynchronous motors - IP 55
Cage rotor

Dimensions in millimetres

– (FF) foot and plain hole flange mounted

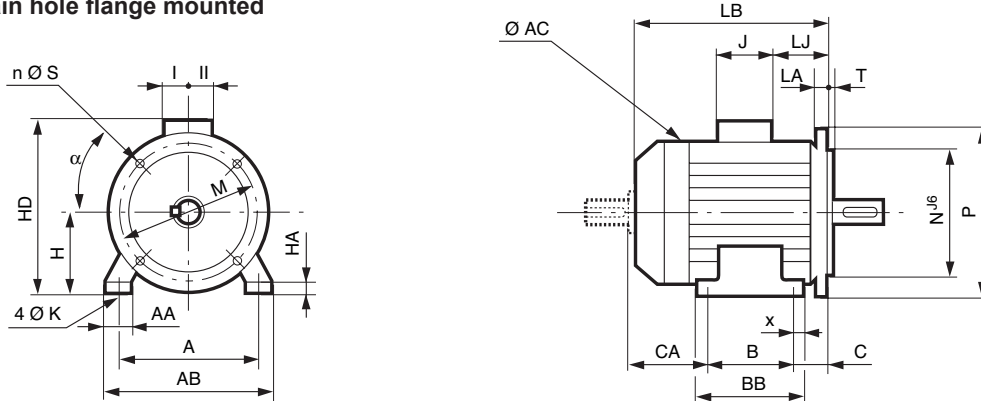

Type	Main dimensions																	
	A	AB	B	BB	C	x	AA	K	HA	H	AC	HD	LB	LJ	J	I	II	Sym.
LSE 80 L	125	157	100	120	50	10	29	9	10	80	170	226	215	13.5	160	55	55	FF165
LSE 90 S	140	172	100	120	56	10	37	10	11	90	190	246	218	13.5	160	55	55	FF165
LSE 90 L	140	172	125	162	56	28	37	10	11	90	190	246	245	13.5	160	55	55	FF165
LSE 100 L	160	196	140	165	63	12	40	12	13	100	200	261	290	14	160	55	55	FF215
LSE 100 LR	160	196	140	165	63	12	40	12	13	100	200	261	290	14	160	55	55	FF215
LSE 100 LG	160	196	140	165	63	12	40	12	13	100	200	261	290	14	160	55	55	FF215
LSE 112 M	190	220	140	165	70	12	52	12	14	112	235	267	334	41	160	55	55	FF215
LSE 112 MG	190	220	140	165	70	12	52	12	14	112	235	276	315	24	160	55	55	FF215
LSE 132 SM	216	250	178	208	89	16	59	12	18	132	280	307	387	25	160	55	55	FF265
LSE 132 M	216	250	178	208	89	16	59	12	18	132	280	307	387	25	160	55	55	FF265
LSE 132 MU	216	250	178	208	89	16	59	12	18	132	280	307	410	25	160	55	55	FF265
LSE 160 MP	254	294	210	294	108	20	64	14.5	25	160	280	368	468	55.5	160	55	55	FF300
LSE 160 L	254	294	254	294	108	20	60	14.5	25	160	310	395	495	44	134	92	63	FF300
LSE 160 MR	254	294	254	294	108	20	64	14.5	25	160	315	357	495	55.5	160	55	55	FF300
LSE 160 M	254	294	210	294	108	20	60	14.5	25	160	310	395	495	44	134	92	63	FF300
LSE 180 MT	279	324	241	316	121	20	79	14.5	28	180	316	428	495	45	205	100	95	FF300
LSE 180 MR	279	324	241	316	121	20	79	14.5	28	180	316	428	520	45	205	100	95	FF300
LSE 180 LU	279	339	279	329	121	25	86	14.5	25	180	350	435	593	54	205	100	95	FF300
LSE 180 L	279	339	279	329	121	25	86	14.5	25	180	350	435	552	54	205	100	95	FF300
LSE 200 LT	318	378	305	365	133	30	108	18.5	32	200	350	455	599	60	205	100	95	FF350
LSE 200 L	318	388	305	375	133	35	103	18.5	36	200	390	475	621	68	205	100	95	FF350
LSE 225 ST	356	431	311	386	149	50	127	18.5	36	225	390	500	627	74	205	100	95	FF400
LSE 225 SR	356	431	286	386	149	50	127	18.5	36	225	390	500	676	74	205	100	95	FF400
LSE 225 MR	356	431	311	386	149	50	127	18.5	36	225	390	500	676	74	205	100	95	FF400

CA dimension and shaft end dimensions identical to those of foot mounted motors.



LSE

Atmospheres containing explosive GAS

totally enclosed three-phase asynchronous motors

CATEGORY 2
ZONE 1

Dimensions

Dimensions of the LSE totally enclosed three-phase asynchronous motors - IP 55
Cage rotor

Dimensions in millimetres

– (FF) plain hole flange mounted

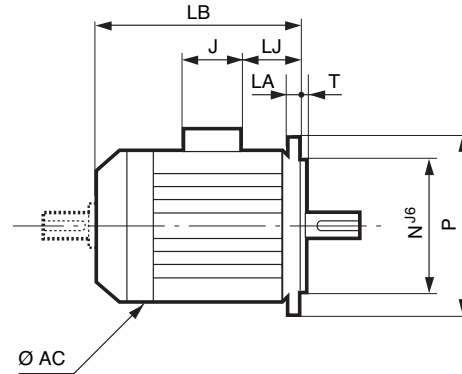
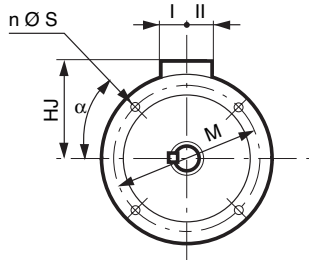

IEC symbol	Flange dimensions								
	M	N	P	T	n	α	S	LA	
FF 165	165	130	200	3.5	4	45	12	10	
FF 165	165	130	200	3.5	4	45	12	10	
FF 165	165	130	200	3.5	4	45	12	10	
FF 215	215	180	250	4	4	45	14.5	12	
FF 215	215	180	250	4	4	45	14.5	12	
FF 215	215	180	250	4	4	45	14.5	12	
FF 215	215	180	250	4	4	45	14.5	12	
FF 215	215	180	250	4	4	45	14.5	12	
FF 265	265	230	300	4	4	45	14.5	14	
FF 265	265	230	300	4	4	45	14.5	14	
FF 265	265	230	300	4	4	45	14.5	14	
FF 300	300	250	350	5	4	45	18.5	14	
FF 300	300	250	350	5	4	45	18.5	14	
FF 300	300	250	350	5	4	45	18.5	14	
FF 300	300	250	350	5	4	45	18.5	14	
FF 300	300	250	350	5	4	45	18.5	14	
FF 300	300	250	350	5	4	45	18.5	14	
FF 300	300	250	350	5	4	45	18.5	14	
FF 350	350	300	400	5	4	45	18.5	15	
FF 350	350	300	400	5	4	45	18.5	15	
FF 400	400	350	450	5	8	22.5	18.5	16	
FF 400	400	350	450	5	8	22.5	18.5	16	
FF 400	400	350	450	5	8	22.5	18.5	16	

Type	Main dimensions						
	AC	LB	HJ	LJ	J	I	II
LSE 80 L	170	215	140	13.5	160	55	55
LSE 90 S	190	238	150	33.5	160	55	55
LSE 90 L	190	265	150	33.5	160	55	55
LSE 100 L	200	290	161	14	160	55	55
LSE 100 LR	200	290	161	14	160	55	55
LSE 100 LG	200	290	161	14	160	55	55
LSE 112 MU	235	334	155	41	160	55	55
LSE 112 MG	235	315	164	41	160	55	55
LSE 132 SM	280	387	175	25	160	55	55
LSE 132 M	280	387	175	25	160	55	55
LSE 132 MU	280	410	175	25	160	55	55
LSE 160 MP	280	468	208	55.5	160	55	55
LSE 160 L	310	495	235	44	134	92	63
LSE 160 MR	315	495	197	55.5	160	55	55
LSE 160 M	310	495	235	44	134	92	63
LSE 180 MT	316	495	248	45	205	100	95
LSE 180 MR	316	520	248	45	205	100	95
LSE 180 LU	350	593	255	54	205	100	95
LSE 180 L	350	552	255	54	205	100	95
LSE 200 LT	350	599	255	60	205	100	95
LSE 200 L	390	621	275	68	205	100	95
LSE 225 MT	390	627	275	74	205	100	95
LSE 225 SR	390	676	275	74	205	100	95
LSE 225 MR	390	676	275	74	205	100	95

Shaft end dimensions identical to those of foot mounted motors.

LSE

Atmospheres containing explosive GAS totally enclosed three-phase asynchronous motors



**CATEGORY 2
ZONE 1**

Dimensions

Dimensions of the LSE totally enclosed three-phase asynchronous motors - IP 55
Cage rotor

Dimensions in millimetres

– (FT) foot and tapped hole flange mounted

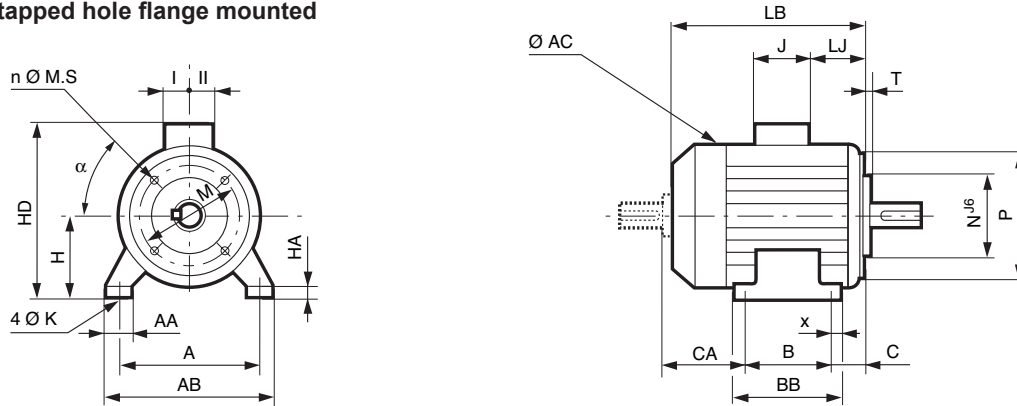

Main dimensions

Type	A	AB	B	BB	C	x	AA	K	HA	H	AC	HD	LB	LJ	J	I	II	Sym.
LSE 80 L	125	157	100	120	50	10	29	9	10	80	170	226	215	13.5	160	55	55	FT100
LSE 90 S	140	172	100	120	56	10	37	10	11	90	190	246	218	13.5	160	55	55	FT115
LSE 90 L	140	172	125	162	56	28	37	10	11	90	190	246	245	13.5	160	55	55	FT115
LSE 100 L	160	196	140	165	63	12	40	12	13	100	200	261	290	14	160	55	55	FT130
LSE 100 LR	160	196	140	165	63	12	40	12	13	100	200	261	290	14	160	55	55	FT130
LSE 100 LG	160	196	140	165	63	12	40	12	13	100	200	261	290	14	160	55	55	FT130
LSE 112 MU	190	220	140	165	70	12	52	12	14	112	235	267	334	41	160	55	55	FT130
LSE 112 MG	190	220	140	165	70	12	52	12	14	112	235	276	315	24	160	55	55	FT130
LSE 132 SM	216	250	178	208	89	16	59	12	18	132	280	307	387	25	160	55	55	FT215
LSE 132 M	216	250	178	208	89	16	59	12	18	132	280	307	387	25	160	55	55	FT215
LSE 132 MU	216	250	178	208	89	16	59	12	18	132	280	307	410	25	160	55	55	FT215
LSE 160 MP	254	294	210	294	108	20	64	14.5	25	160	280	368	468	55.5	160	55	55	FT215
LSE 160 MR	254	294	254	294	108	20	60	14.5	25	160	310	395	495	44	134	92	63	FT215

CA dimension and shaft ends dimensions identical to those of the foot mounted motors.

LSE

Atmospheres containing explosive GAS



totally enclosed three-phase asynchronous motors

**CATEGORY 2
ZONE 1**

Dimensions

Dimensions of the LSE totally enclosed three-phase asynchronous motors - IP 55
Cage rotor

Dimensions in millimetres

– (FT) tapped hole flange mounted

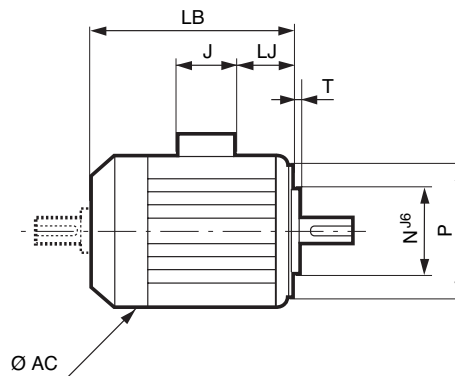
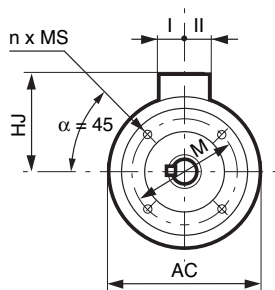

IEC symbol	Flange dimensions					
	M	N	P	T	n	MS
FT 100	100	80	120	3	4	M6
FT 115	115	95	140	3	4	M8
FT 115	115	95	140	3	4	M8
FT 130	130	110	160	3.5	4	M8
FT 130	130	110	160	3.5	4	M8
FT 130	130	110	160	3.5	4	M8
FT 130	130	110	160	3.5	4	M8
FT 215	215	180	250	4	4	M12
FT 215	215	180	250	4	4	M12
FT 215	215	180	250	4	4	M12
FT 215	215	180	250	4	4	M12
FT 215	215	180	250	4	4	M12

Type	Main dimensions						
	AC	LB	HJ	LJ	J	I	II
LSE 80 L	170	215	146	13.5	160	55	55
LSE 90 L	190	245	156	13.5	160	55	55
LSE 90 S	190	218	156	13.5	160	55	55
LSE 100 L	200	290	161	14	160	55	55
LSE 100 LG	200	290	161	14	160	55	55
LSE 100 LR	200	290	161	14	160	55	55
LSE 112 MG	235	315	164	41	160	55	55
LSE 112 MU	235	334	155	41	160	55	55
LSE 132 M	280	387	175	25	160	55	55
LSE 132 MU	280	410	175	25	160	55	55
LSE 132 SM	280	387	175	25	160	55	55
LSE 160 MP	280	468	208	55.5	160	55	55
LSE 160 MR	315	495	197	55.5	160	55	55

Shaft end dimensions identical to those of foot mounted motors.

