

Open continuous current (DC) motors MS 1 - MS 2

General information



Open continuous current (dc) motors conforming to the IEC specifications.

- MS 1 :
 - frame size 80 to 132 mm,
 - power 0.44 to 8.85 kW.
- MS 2 :
 - frame size 112 and 132 mm,
 - power 1.9 to 18.5 kW.

Use conditions

S1 duty.
 Altitude below 1000 m.
 Ambient temperature less than or equal to 40°C.
 Absolute humidity within the range 5 to 23g/m³.
 Current range from 50 to 100 % of I_N in continuous operation and higher in transient operation.

N.B.: refer to the technical catalogue to check the axial or radial loads, overload capacities, protection system of the motor.



Component	Materials	Remarks
Stator (or casing)	Magnetic sheet steel assembly Enameled electrolytic copper, class H	- pre-stressed steel lamination assembly welded using TIG process - main poles integrated throughout range range - auxiliary poles are separate (MS 1001, 1121 and 1122), or integrated (MS 1321 and 1322) - insulation system class F (MS 1) or H (MS 2)
Armature	Insulated low carbon magnetic steel laminations Enameled electrolytic copper, class H	- the low carbon content guarantees long term stability of the magnetic characteristics - semi-enclosed inclined slots - binding reinforced with heat-treated polymerised fibreglass - insulation system class F (MS 1) or H (MS 2)
Commutator	Silver-plated copper on resin	- toothed type - large number of blades
Shaft	Steel	- open key - straight ended key (MS 1), round ended key (MS 2)
Brush holder Brushes	Thermoset resin and bronze Electrographitic compound	- moulded, rigid - adjustment position marked - evenly-spaced accurate brush holders
End shields	FGL cast iron	- plain hole flange (FF) fixed to end shield (MS 801 to 1321) - plain hole flange (FF) fixed to end shield or tapped hole flange (FT) plain hole flange mounted shaft ends (MS 1122 to 1322)
Bearings and lubrication	Steel	- ball bearings, set C3 - 2RS type, sealed, greased for life - front bearing preloaded - translational movement of rear bearing blocked
Fan	Composite material (MS 1) Aluminium alloy or steel sheet metal (MS 2)	- self-cooled motor (MS 801 to 1121 and 1321) - radial fan (MS 1122 and 1322)
Terminal box	Composite material (MS 1) or aluminium alloy (MS 2)	- IP 55 (sealed) - can be turned in 4 directions - 4 terminals (MS 801 to 1121, 1122 and 1321) - 6 terminals (for series-parallel excitation (MS 1322) - connection of options to dominos (MS 2)

Armature voltage according to power supplies					
Single phase sector	Maximum armature voltage		Three-phase sector	Maximum armature voltage	
	Variable speed drive			Variable speed drive	
	1 quadrant	4 quadrants		1 quadrant	4 quadrants
V	V	V	V	V	V
220 - 230	180 - 190	140 - 150	220	250	250
380 - 400	310 - 320	250 - 260	230	260	260
415	340	270	240	270	270
			380	440	440
			400	460	460
			415	470	470

Excitation voltage according to power supplies	
Single phase sector	Excitation voltage
V	V
220 - 230	190 - 210
240	220
380	340 (only MS 1322)
400	360 (only MS 1322)
415	360 (only MS 1322)

Open continuous current (DC) motors MS 1 - MS 2

Mounting positions and protection indices

Foot mounted motors

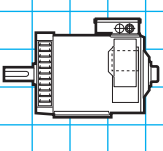
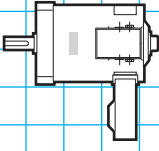
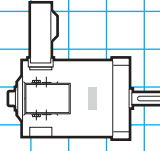
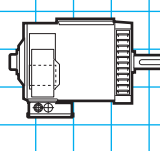
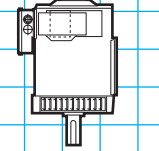
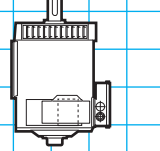
					
IM 1001 (IM B3)	IM 1051 (IM B6)	IM 1061 (IM B7)	IM 1071 (IM B8)	IM 1011 (IM V5)	IM 1031 (IM V6)
MS 1 IP 21	MS 1 IP 20	MS 1 IP 20	MS 1 IP 20	MS 1 IP 21	MS 1 IP 21
MS 2 IP 23	MS 2 IP 20	MS 2 IP 20	MS 2 IP 20	MS 2 IP 20	MS 2 IP 21

(FF) plain hole flange mounted motors

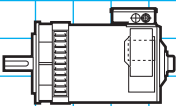
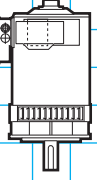
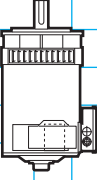
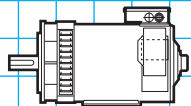
			
IM 3001 (IM B5)	IM 3011 (IM V1)	IM 3031 (IM V3)	IM 2001 (IM B35) ¹
MS 1 IP 21	MS 1 IP 21	MS 1 IP 21	MS 1 IP 21
MS 2 IP 23	MS 2 IP 20	MS 2 IP 21	MS 2 IP 23

(FT) tapped hole flange mounted motors (only MS 2)

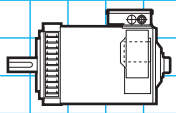
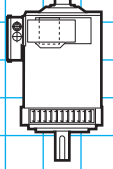
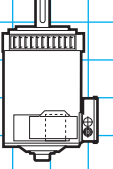
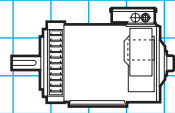
			
IM 3601 (IM B14)	IM 3611 (IM V18)	IM 3631 (IM V19)	IM 2101 (IM B34) ¹
MS 2 IP 23	MS 2 IP 20	MS 2 IP 21	MS 2 IP 23

Position of the terminal box (TB) and the forced ventilation (VF)

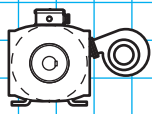
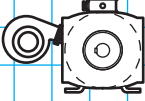
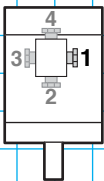
			
TB : standard	VF : D	MS 1 - 1 : standard	MS 2 - 1 : standard
MS 2 ² VF : B standard			

1. Flange and feet position.

2. Cooling mode IC 06 as standard, or IC 17 (air supply by entry of piped air, free output).

Open continuous current (DC) motors MS 1

Adaptation possibilities

Leroy-Somer offers various options and adaptation possibilities for its motors. They are described below and offered in this catalogue, in the section relating to gearboxes, or in the chapter Speed variation for the types of motorised variable speed drives selected. For the applications that are not specified in the selection tables, consult the technical specialists at Leroy-Somer.

MS 1 motors may be associated to :

- speed reducers with universal mounting :
 - Cb 2000 with coaxial or parallel axles,
 - Ot 2000 with conical torque,
 - Mub 2000 with hollow shaft,
 - Pl 2000 with planetary gear .
- electronic variable speed drive :
 - 1 single phase quadrant DMV 201,
 - 4 single phase quadrants DMV 242,
 - 1 three-phase quadrant DMV 2322,
 - 4 three-phase quadrants DMV 2342.

The options :

- plain holes flange
- speed detection :
 - tachometric dynamo, 60 V/1000 min⁻¹.

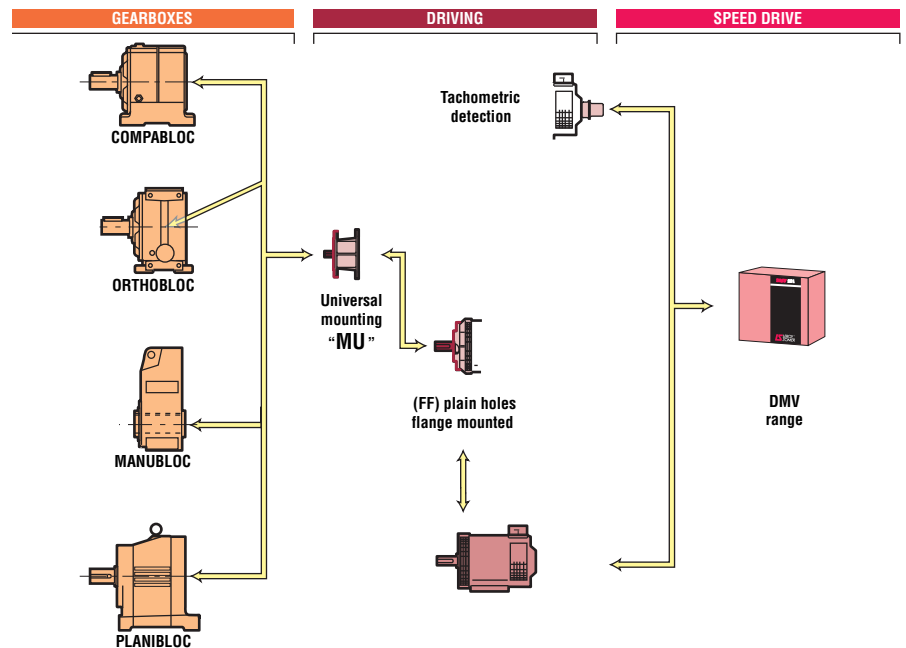

Designation / Codification

MS	801	L 08	260 V	2300 min⁻¹	0.7 kW	IM 1001	190 V	IC 01	IP 20
Motor type	Frame size Polarity	Stator designation Builder index	Armature voltage	Rated speed	Rated power	Construction form	Excitation voltage	Cooling index	Protection index

Codification example:

Motor 0.7 kW, 2 300 min⁻¹, IM 1001, 260/190 V

Designation

MS 801 L08 0.7 kW

Code

-

All the products in this catalogue have a code.

The coding table is incorporated in the price list together with the list of designations.

Each electromechanical product is classified first in order of power and then in order of speed.

Open continuous current (DC) motors MS 2

Adaptation possibilities

MS 2 motors may be associated to :

gearboxes with universal mounting :

- Cb 2000 with coaxial or parallel axes,
- Ot 2000 with conical torque,
- Mub 2000 with hollow shaft,
- PI 2000 with planetary gear .

electronic variable speed drive :

- 1 single phase quadrant DMV 201,
- 4 single phase quadrants DMV 242,
- 1 three-phase quadrant DMV 2322,
- 4 three-phase quadrants DMV 2342.

The options :

- **tapped hole or plain hole flanges**
- **hollow shaft speed detection (i) :**
- tachometric dynamo, 60 V/1000 min⁻¹,
- **coupling speed detection (i) :**
- tachometric dynamo, 60 V/1000 min⁻¹,
- **safety brakes (i), with or without release lever :**
- 32 and 80 Nm.
- **air filter for forced ventilation**
- **air flow detection**
- **second shaft end**
- **possible combinations :**
- i + i

Leroy-Somer offers various options and adaptation possibilities for its motors. They are described below and offered in this catalogue, in the section relating to reducers, or in the chapter Speed variation for the types of motorised variable speed drives selected. For the applications that are not specified in the selection tables , consult the technical specialists at Leroy-Somer.

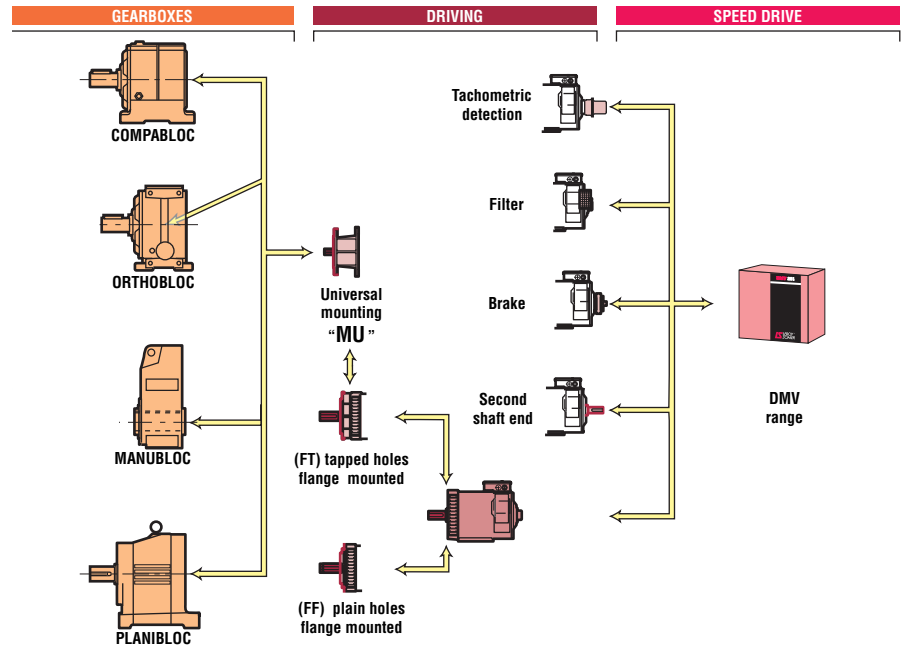

Designation / Codification

MS	1322	M 32	440 V	3350 min⁻¹	18.5 kW	IM 1001	190 V	IC 06	IP 21S
Motor type	Frame size Polarity	Stator designation Builder index	Armature voltage	Rated speed	Rated power	Construction form	Excitation voltage	Cooling index	Protection index

Codification example :

Motor 18.5 kW, 3350 min⁻¹, IM 1001, 440/190 V

Designation	Code
MS 1322 M32 18.5 kW	-

All the products in this catalogue have a code. The coding table is incorporated in the price list together with the list of designations. Each electromechanical product is classified first in order of power and then in order of speed.

Open continuous current (DC) motors MS 1 - MS 2

Preselection chart

Selection example :

Data:

- 1.7 kW at 2900 min⁻¹
- variable speed drive output voltage 170 V.

Operating mode:

- Preselect the motor size using the chart opposite : MS 1001.

- In the selection table (see the next page for this size, of which an extract appears below) look for the power closest to 1.7 kW : P = 1.85 kW at 3000 min⁻¹

How can the rated speed be adjusted to the required speed?

By adjusting the armature voltage (output of the variable speed drive), without exceeding the rated value, the power being corrected proportionally.

In this situation, in order to be used at 2900 min⁻¹, the motor will be supplied at:

$$170 \times \frac{2900}{3000} = 164 \text{ V,}$$

$$\text{and } P = 1.85 \times \frac{164}{170}, \text{ or } 1.78 \text{ kW.}$$

Selected motor :

MS 1001 L 03 - 170 V - 1.85 kW...
IC 01

Note : By introducing an additional self-induction coil into the power supply circuit (see the 1st column in the selection table), the output power will be changed to :

$$P = 2.13 \times \frac{164}{170}, \text{ that is to say } 2.05 \text{ kW.}$$

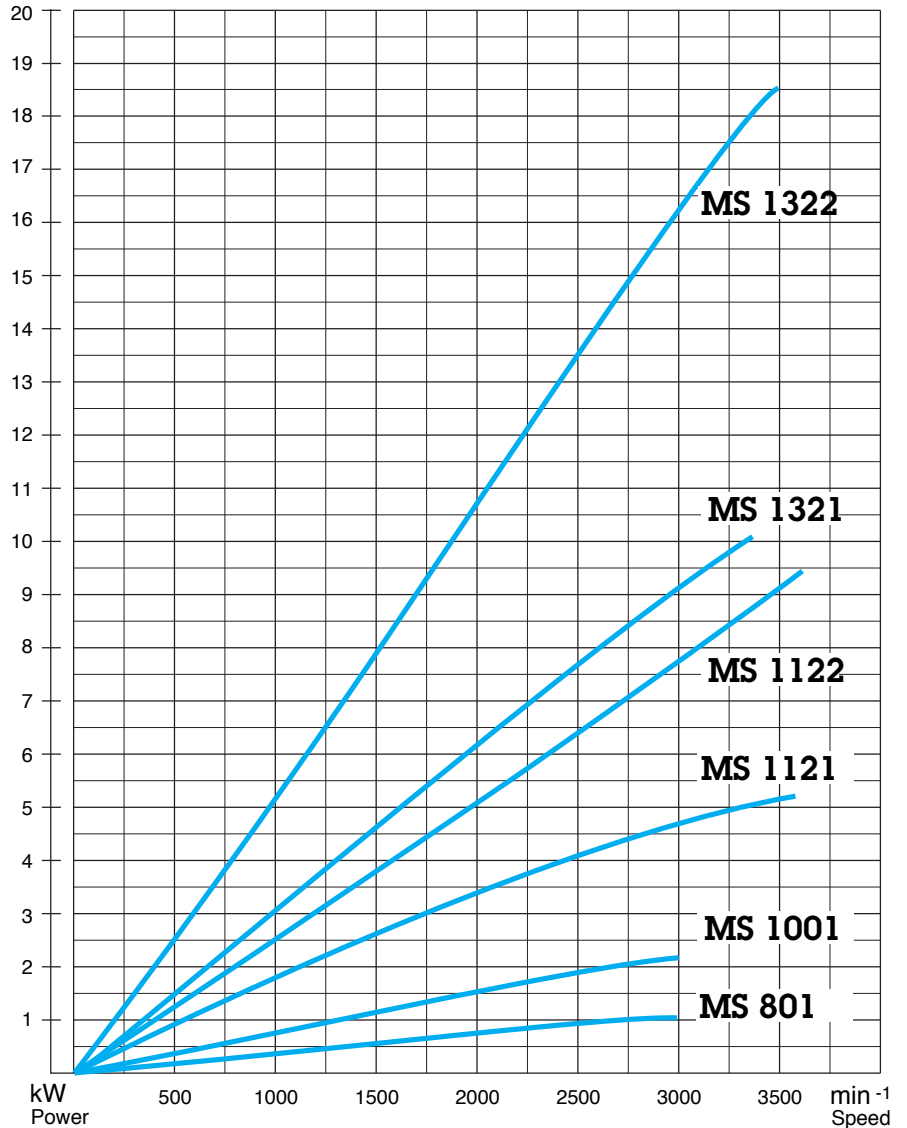

P	P	Single phase power supply				Three-phase power supply	Additional self-induction coil FF = 1.2 ¹	MS motor size	Stator designation and builder index
		Rotation speed n for armature voltage U							
with self-induction coil ¹	without self-induction coil	170 V	260 V	310 V	440 V				
kW	kW	min ⁻¹	min ⁻¹	min ⁻¹	min ⁻¹	mH			
1.5	1.3	900				30	1121	M 06	
1.61	1.4		2300			20	1001	L 06	
1.96	1.7		2750			15	1001	L 05	
1.96	1.7			2740		20	1001	L 06	
2.13	1.85	3000				5	1001	L 03	
2.3	2	1400				10	1121	M 04	
2.3	2		1400			30	1121	M 06	
2.3	2			3300		15	1001	L 05	
	2.41				3870		1001	L 06	
2.76	2.4	1300				15	1321	S 33	

Open continuous current (DC) motors MS 1

Selection

MS 1 motor - Class F
Mixed bridge single phase or full bridge three-phase power supply
IC 01 cooling (self-ventilated)
S1 duty - Ambient temperature $\leq 40\text{ }^{\circ}\text{C}$

P	P	Single phase supply				Three phase supply		Additional self-induction coil	J	M	I	η	L	$R_{115^{\circ}}$	U_{\max}	Motor	Stator
		170 V	260 V	310 V	440 V	FF = 1.2 ¹	FF = 1.6 ¹										
with self-induction coil ^f	without self-induction coil	min ⁻¹	min ⁻¹	min ⁻¹	min ⁻¹	mH	kg.m ²	N.m	A		mH	Ω	V		index	Qty	
0.5	0.44	1500				30	0.003	3	3.5	0.74	94	5.5	460	801	L 08	2	
0.7	0.6	995				50	0.006	6	4.4	0.81	130	5.1	340	1001	L 09	2	
0.8	0.7		2300			30	0.003	3	3.5	0.77	94	5.5	440	801	L 08	2	
0.92	0.8			2750		30	0.003	3	3.5	0.74	94	5.5	440	801	L 08	2	
1.03	0.9		1530			50	0.006	6	4.4	0.79	130	5.1	340	1001	L 09	2	
1.07	0.93	3000				10	0.003	3	7	0.79	23	1.35	180	801	L 04	2	
1.1	0.93	1500				20	0.006	6	6.5	0.84	57	2.35	440	1001	L 06	2	
1.26	1.1	1800				15	0.006	6	7.5	0.86	43	1.75	340	1001	L 05	2	
1.26	1.1			1830		50	0.006	6	4.4	0.81	130	5.1	340	1001	L 09	2	
	1.2				3870		0.003	3	3.5	0.79	94	5.5	460	801	L 08	2	
1.5	1.3	900				30	0.02	14	9	0.85	80	3.01	440	1121	M 06	2	
1.61	1.4		2300			20	0.006	6	6.5	0.83	57	2.35	440	1001	L 06	2	
1.96	1.7		2750			15	0.006	6	7.5	0.87	43	1.75	340	1001	L 05	2	
1.96	1.7			2740		20	0.006	6	6.5	0.85	57	2.35	440	1001	L 06	2	
2.13	1.85	3000				5	0.006	6	12.5	0.87	15	0.5	180	1001	L 03	2	
2.3	2	1400				10	0.02	14	13.5	0.87	34	1.26	440	1121	M 04	2	
2.3	2		1400			30	0.02	14	9	0.86	80	3.01	440	1121	M 06	2	
2.3	2			3300		15	0.006	6	7.5	0.86	43	1.75	340	1001	L 05	2	
	2.41				3870		0.006	6	6.5	0.85	57	2.35	460	1001	L 06	2	
2.76	2.4	1300				15	0.04	18	16.5	0.86	37	1.14	440	1321	S 33	2	
2.76	2.4	950				20	0.05	24	17	0.83	54	1.32	440	1321	M 33	2	
2.82	2.45			1700		30	0.02	14	9	0.87	80	3.01	440	1121	M 06	2	
2.82	2.6	1850				5	0.02	13	18	0.85	20	0.8	340	1121	M 03	2	
3.57	3.1		2150			10	0.02	14	13.5	0.88	34	1.26	440	1121	M 04	2	
	3.46				2410		0.02	14	9	0.87	80	3.01	460	1121	M 06	2	
4.26	3.7		2000			10	0.04	18	16.5	0.86	37	1.14	440	1321	S 33	2	
4.31	3.75			2600		10	0.02	14	13.5	0.88	34	1.26	440	1121	M 04	2	
4.49	3.9		1450			20	0.05	26	17	0.88	54	1.32	440	1321	M 33	2	
4.6	4	2900				3	0.02	13	28	0.84	9	0.34	180	1121	M 02	2	
4.6	4		2800			5	0.02	14	18	0.86	20	0.8	340	1121	M 03	2	
5	4.35			2350		10	0.04	18	16.5	0.85	37	1.14	440	1321	S 33	2	
5.29	4.6			1800		20	0.05	24	17	0.87	54	1.32	440	1321	M 33	2	
5.64	4.9			3400		5	0.02	14	18	0.83	20	0.8	340	1121	M 03	2	
	5.24				3670		0.02	14	13.5	0.88	34	1.26	460	1121	M 04	2	
	6.18				3350		0.04	18	16.5	0.85	37	1.14	460	1321	S 33	2	
6.9	6	2250				3	0.05	25	40	0.88	11	0.34	260	1321	M 22	2	
	6.7				2510		0.05	25	17	0.89	54	1.32	460	1321	M 33	2	
10.2	8.85		3300			3	0.05	26	40	0.85	11	0.34	260	1321	M 22	2	

1. For single phase power supply.
Selection example : see page B4.5.

P : Rated power
J : Inertia moment
M : Rated moment
I : Permissible current in continuous operation
 η : Efficiency
L : Motor self-induction coil
R : Armature resistance at 115 °C
 U_{\max} : Maximum armature voltage

Open continuous current (DC) motors MS 1122 M

Selection

MS 2 motor - IC 06 ventilation - Class H

Mixed bridge single phase or full bridge three-phase power supply

S1 duty - Ambient temperature $\leq 40\text{ }^{\circ}\text{C}$ - Total weight : foot, 56 kg ; flange, 59 kg - Moment of inertia : 0.02 kg.m²

P FF=1.05	P with self induction coil	P without self induction coil	Single phase supply				Three phase supply				Addition self-induc- tion coil FF = 1,2	M N.m	I A	η except for excit.	L mH	R _{115°} Ω	U _{max} V	Manuf. index	Qty
			Rotation speed n for armature voltage U																
			160 V min ⁻¹	180 V min ⁻¹	260 V min ⁻¹	310 V min ⁻¹	400 V min ⁻¹	440 V min ⁻¹	460 V min ⁻¹										
1.9								890			20	6.5 ¹	0.72	430	16.5	460	14		
2.1										970	21	6.4 ¹	0.73	430	16.5	460	14		
2.2											21	6.4 ¹	0.73	430	16.5	460	14		
3.4									1380		24	10.3 ¹	0.81	171	6.63	460	09		
3.7										1500	24	10.3 ¹	0.82	171	6.63	460	09		
3.8											23	10 ¹	0.82	171	6.63	460	09		
	1.4	1.2	630								30	21	10.5 ²	0.7	110	3.82	460	07	
	1.5	1.3		720							30	20	10 ²	0.73	110	3.82	460	07	
	2.2	1.9			1080						30	19	9.5 ²	0.78	110	3.82	460	07	
	2.8	2.4				1320					30	20	9.5 ¹	0.81	110	3.82	460	07	
4.7									1760		26	14 ¹	0.83	110	3.82	460	07		
5.3										1940	26	14 ¹	0.85	110	3.82	460	07		
5.3											25	13.5 ¹	0.86	110	110	460	07		
	1.7	1.5	730								25	22	11.5 ²	0.73	90	3.01	460	06	
	1.9	1.6		830							25	22	11 ²	0.78	90	3.01	460	06	
	2.7	2.3			1260						25	20	11 ²	0.81	90	3.01	460	06	
	3.2	2.8				1530					25	20	11 ²	0.83	90	3.01	460	06	
5.5									2060		25	16 ¹	0.86	90	3.01	460	06		
6.1										2270	26	16 ¹	0.86	90	3.01	460	06		
6.2											25	15.5 ¹	0.87	90	3.01	460	06		
	2.3	2	880								15	25	14.5 ²	0.78	62	1.97	460	05	
	2.3	2		1000							15	22	14 ²	0.8	62		460	05	
	3.5	3			1520						15	22	13.6 ²	0.84	62		460	05	
	4.2	3.6				1840					15	22	13.6 ²	0.85	62		460	05	
6.9									2480		27	20 ¹	0.86	62		460	05		
7.7										2720	27	20 ¹	0.87	62		460	05		
7.8											26	19.5 ¹	0.87	62		460	05		
	2.6	2.3	1100								10	23	17.5 ²	0.82	38	1.26	460	04	
	3	2.6		1250							10	23	17 ²	0.84	38	1.26	460	04	
	4.4	3.8			1900						10	22	17 ²	0.85	38	1.26	460	04	
	5.3	4.6				2300					10	22	17 ²	0.86	38	1.26	460	04	2
8.6									3090		27	24.7 ¹	0.87	38	1.26	460	04		
9.5										3400	27	24.7 ¹	0.88	38	1.26	460	04		
9.5										3550	26	23.5 ¹	0.88	38	1.26	460	04		

1. Maximum permissible overload: 1.2 I_N for motor without tachometric detector, and 1.6 I_N for motor fitted with tachometric detector.
2. Current corresponding to power supply without self-induction coil (FF = 1.6).

Selection example : see page B4.5.

P : Rated power
J : Inertia moment
M : Rated moment
I : Permissible current in continuous operation

η : Efficiency
L : Motor self-induction coil
R : Armature resistance at 115 °C
U_{max} : Maximum armature voltage

Open continuous current (DC) motors MS 1322 S

Selection

MS 2 motor - IC 06 ventilation - Class H

Mixed bridge single phase or full bridge three-phase power supply

S1 duty - Ambient temperature $\leq 40\text{ }^{\circ}\text{C}$ - Total weight : foot, 76 kg ; flange, 79 kg - Moment of inertia : 0.04 kg.m²

P FF=1.05	P with	P without	Single phase supply				Three phase supply			Addition self-induc- tion coil FF = 1.2	M	I	η except for excit.	L	$R_{115^{\circ}}$	U_{\max}	Manuf. index	Qty
			Rotation speed n for armature voltage U															
			160 V	180 V	260 V	310 V	400 V	440 V	460 V									
kW	kW	kW	min ⁻¹	min ⁻¹	min ⁻¹	min ⁻¹	min ⁻¹	min ⁻¹										
3.3								840		38	11 ¹	0.74	325	10.3	460	39		
3.4										35	10.5 ¹	0.74	325	10.3	460	39		
3.5										35	10 ¹	0.75	325	10.3	460	39		
	2.9	2.5			870					50	12.5 ²	0.75	133	4.53	460	36		
	3.5	3				1040				50	12.4 ²	0.79	133	4.53	460	36		
5.6								1350		40	16.5 ¹	0.84	133	4.53	460	36		
5.9										38	16 ¹	0.85	133	4.53	460	36		
5.9										36	15 ¹	0.85	133	4.53	460	36		
	2.8	2.4	760							20	20.5 ²	0.73	57	1.96	460	34		
	3.4	2.9		850						20	20 ²	0.78	57	1.96	460	34		
	5	4.3			1320					20	20 ²	0.82	57	1.96	460	34		
	6	5.2				1570				20	20 ²	0.84	57	1.96	460	34		
8.6								2050		40	25 ¹	0.86	57	1.96	460	34		
9.5										40	25 ¹	0.86	57	1.96	460	34		
9.6										39	24 ¹	0.87	57	1.96	460	34		
	3.8	3.3	1040							15	26 ²	0.79	37	1.14	460	33		
	4.2	3.7		1170						15	25.5 ²	0.8	37	1.14	460	33		
	6.2	5.4			1810					15	25 ²	0.83	37	1.14	460	33		
	7.6	6.6				2150				15	25 ²	0.85	37	1.14	460	33	2	
11.2								2830		38	32 ¹	0.87	37	1.14	460	33		
12.3										38	32 ¹	0.88	37	1.14	460	33		
12.3										36	30.5 ¹	0.88	37	1.14	460	33		
	5.4	4.7	1540							10	35.2 ²	0.83	32	0.52	340	32		
	6.2	5.4		1720						10	35 ²	0.85	32	0.52	340	32		
	9.1	7.9			2690					10	34.7 ²	0.87	32	0.52	340	32		
	10.8	9.4				3190				10	34.7 ²	0.88	32	0.52	340	32		

1. Maximum permissible overload: 1.2 I_N for motor without tachometric detector, and 1.6 I_N for motor fitted with tachometric detector.

2. Current corresponding to power supply without self-induction coil (FF = 1.6).

Selection example : see page B4.5.

P : Rated power

J : Inertia moment

M : Rated moment

I : Permissible current in continuous operation

η : Efficiency

L : Motor self-induction coil

R : Armature resistance at 115 °C

U_{\max} : Maximum armature voltage

Open continuous current (DC) motors MS 1322 M

Selection

MS 2 motor - IC 06 ventilation - Class H

Mixed bridge single phase or full bridge three-phase power supply

S1 duty - Ambient temperature $\leq 40\text{ }^{\circ}\text{C}$ - Total weight : foot, 91 kg ; flange, 94 kg - Moment of inertia : 0.05 kg.m²

P FF=1.05	P with	P without	Single phase supply				Three phase supply			Addition self-induction coil FF = 1.2	M N.m	I A	η except for excit.	L mH	$R_{115^{\circ}}$ Ω	U_{\max} V	Manuf. index	Qty
			Rotation speed for armature voltage U															
			160 V	180 V	260 V	310 V	400 V	440 V	460 V									
4.1							840		47	14 ¹	0.73	271	6.92	460	37			
4.5								920	47	14 ¹	0.73	271	6.92	460	37			
4.6								960	46	13.5 ¹	0.74	271	6.92	460	37			
	3.6	3.1			820				50	42	16 ²	0.74	131	3.52	460	35		
	4.4	3.8				980			50	43	15.6 ²	0.78	131	3.52	460	35		
6.4							1270		48	19.2 ¹	0.83	131	3.52	460	35			
7.1								1390	49	19.2 ¹	0.84	131	3.52	460	35			
7.2								1460	47	18.5 ¹	0.84	131	3.52	460	35			
	4.7	4.1			980				30	46	20.5 ²	0.76	104	2.28	460	34		
	5.8	5				1170			30	47	20 ²	0.8	104	2.28	460	34		
8.1							1520		51	24 ¹	0.84	104	2.28	460	34			
9.2								1670	53	24 ¹	0.85	104	2.28	460	34			
9.2								1740	50	23.5 ¹	0.85	104	2.28	460	34			
	3.5	3	750						15	45	26 ²	0.72	49	1.32	460	33		
	4	3.5		840					15	45	25.5 ²	0.77	49	1.32	460	33		
	6.1	5.3			1310				15	44	25 ²	0.81	49	1.32	460	33		
	7.4	6.4				1560			15	45	25 ²	0.83	49	1.32	460	33		
10.9							2030		51	32 ¹	0.85	49	1.32	460	33			
11.7								2240	50	32 ¹	0.86	49	1.32	460	33			
12								2320	49	30.5 ¹	0.86	49	1.32	460	33			
	5.2	4.5	1120						10	44	35.2 ²	0.79	21	0.33	460	32		
	5.8	5.1		1260					10	44	35 ²	0.81	21	0.33	460	32		
	8.7	7.6			1960				10	42	34.7 ²	0.84	21	0.33	460	32		
	10.6	9.2				2340			10	43	34.7 ²	0.86	21	0.33	460	32		
16.8							3050		53	48 ¹	0.88	21	0.33	460	32			
18.5								3350	53	48 ¹	0.88	21	0.33	460	32			
18.5								3500	50	46 ¹	0.88	21	0.33	460	32			

1. Maximum permissible overload: 1.2 I_N for motor without tachometric detector, and 1.6 I_N for motor fitted with tachometric detector.
2. Current corresponding to power supply without self-induction coil (FF = 1.6).

Selection example : see page B4.5.

P : Rated power
J : Inertia moment
M : Rated moment
I : Permissible current in continuous operation

η : Efficiency
L : Motor self-induction coil
R : Armature resistance at 115 °C
 U_{\max} : Maximum armature voltage

Open continuous current (DC) motors MS 1 - MS 2

Availability according to construction

Type	Construction characteristics
MS 801 MS 1001 MS 1121 MS 1122 MS 1321 MS 1322	<ul style="list-style-type: none"> • IP 20 protection • Self-ventilated • (FF) plain holes foot, flange, or foot and flange mounted • Terminal box in position A • Standard main shaft end • Sealed ball bearings • Balancing normal class N • Mounting of a tachometric dynamo REO or equivalent • Separate excitation voltage 190 V
MS 1122 MS 1322	<ul style="list-style-type: none"> • Forced ventilation in position B or D • Stopped air flow detector • Air filter • Thermal detection via PTO
MS 1122 MS 1322	<ul style="list-style-type: none"> • Other flanges available on estimate • Special shaft end on estimate • Optional 2nd shaft end • Balancing class R (reduced) • Sealed joint in the flange • Brake option • Brake with tachometric dynamo or pulse generator • Brake with release lever • Thermal detection via PTC • Excitation : <ul style="list-style-type: none"> - 210V - other voltages on estimate • Execution other than IEC

Open continuous current (DC) motors MS 1 - MS 2

Notes

B

Open continuous current (DC) motors MS 1

Dimensions

Dimensions of the MS 1 open continuous current (dc) motors

Dimensions in millimetres

- foot mounted

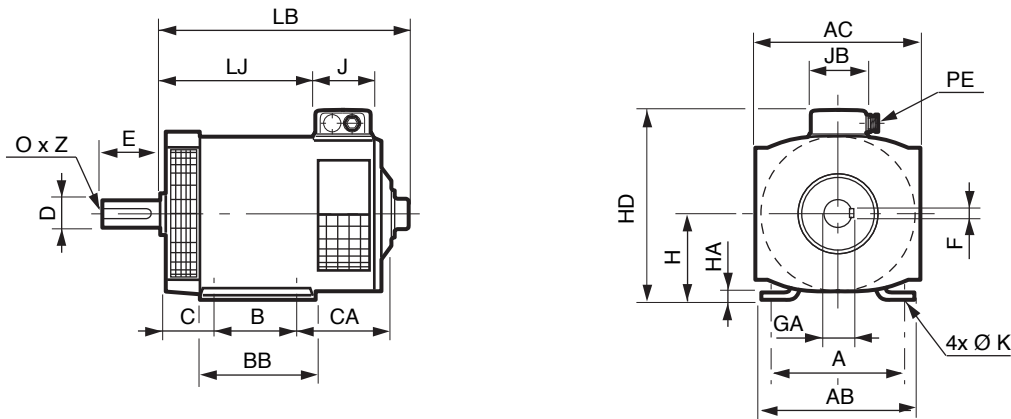

- (FF) plain hole flange mounted

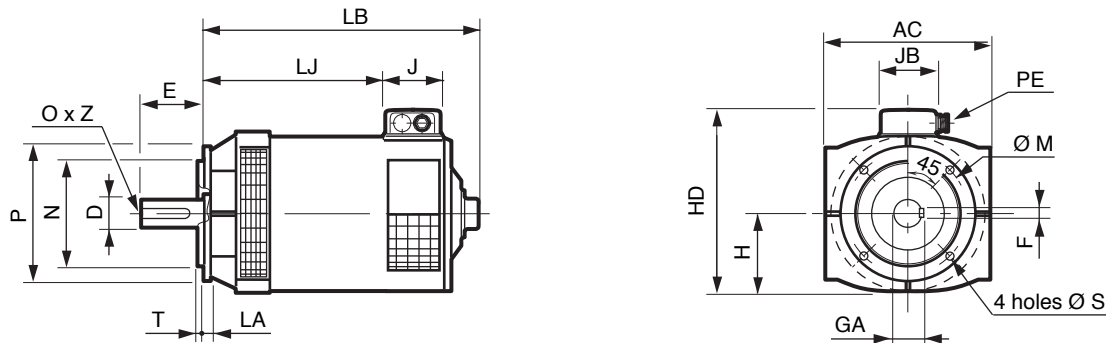

Type	Motor																Weight (kg)	
	A	AB	AC	B	BB	C	CA	H	HA	HD	J	JB	K	LB	LJ	PE	feet	flange
MS 801 L	125	150	160	100	120	50	151	80	2	204	80	80	9	316	167	16	20	21
MS 1001 L	160	185	200	140	170	63	161	100	3	248	80	80	10	364	227	16	37	38
MS 1121 M	190	220	225	140	170	70	205	112	3	272	80	80	12	414	278	16	54	57
MS 1321 S	216	250	260	140	180	89	202	132	3	332	163	163	12	471	218	21	74	77
MS 1321 M	216	250	260	178	218	89	224	132	3	332	163	163	12	491	278	21	89	92

Type	Plain hole flange							Shaft end					
	LB	M	NJ6	P	LA	S	T	DJ6	E	F	GA	O	Z
MS 801 L	353	115	95	140	10	9	3	14	30	5	16	M5	12
MS 1001 L	402	130	110	160	10	9	3.5	19	40	6	21.5	M6	12
MS 1121 M	456	165	130	200	12	11	3.5	24	50	8	27	M8	15
MS 1321 S	518	215	180	250	14	14	4	28	60	8	31	M10	20
MS 1321 M	538	215	180	250	14	14	4	28	60	8	31	M10	20

Open continuous current (DC) motors MS 2

Dimensions

Dimensions of the MS 2 open continuous current (dc) motors

Dimensions in millimetres

- feet mounted

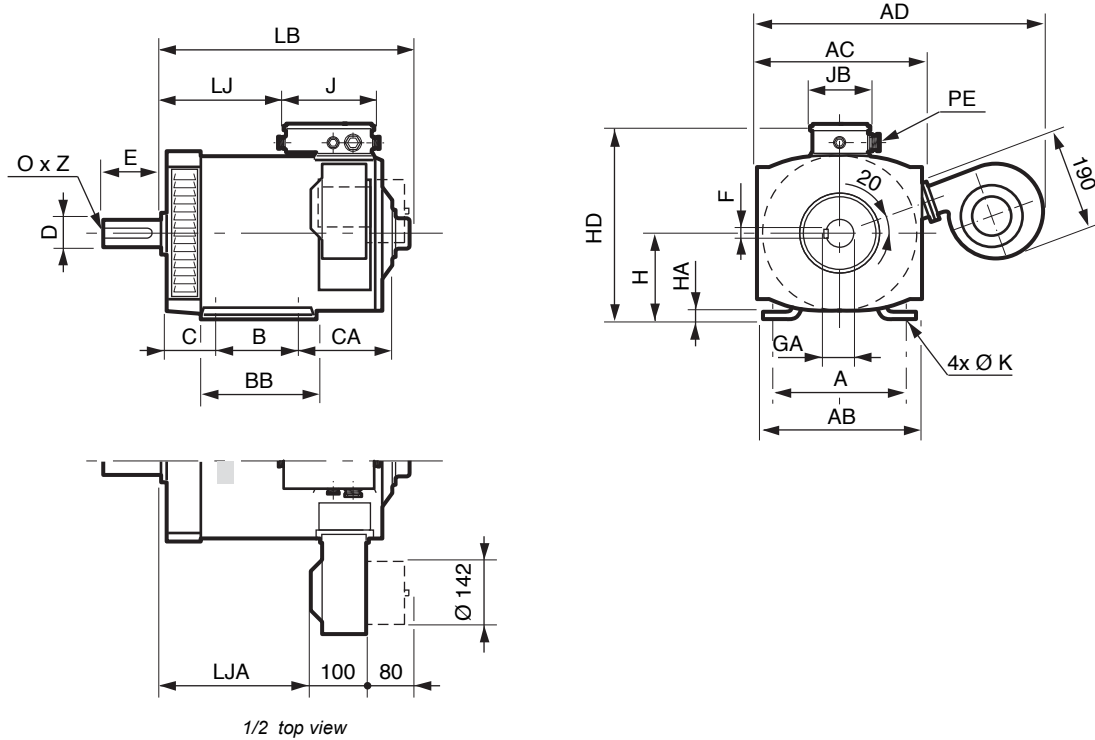

- (FF) plain hole flange mounted or (FT) tapped hole flange mounted

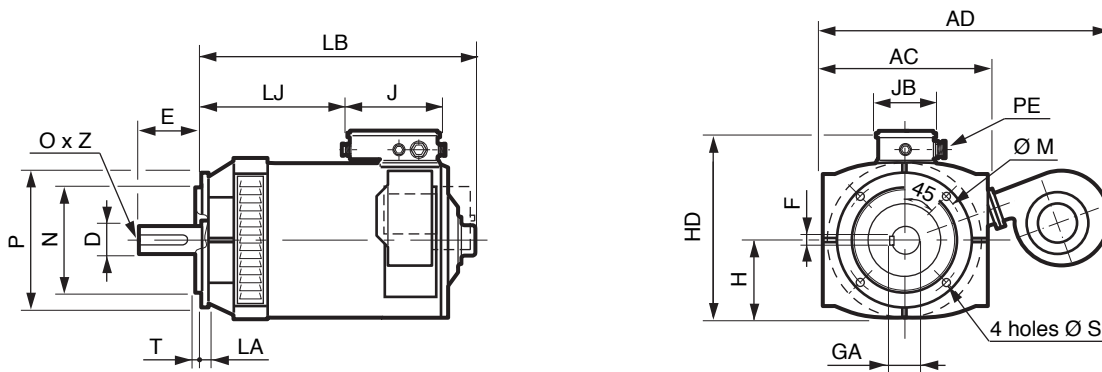

Type	Motors																	
	A	AB	AC	AD	B	BB	C	CA	H	HA	HD	J	JB	K	LB	LJ	LJA	PE
MS 1122 M	190	220	223	427	140	170	70	179	112	4	290	160	110	12	417	210	257	¹
MS 1322 S	216	250	260	460	140	180	89	200	132	5	329	160	110	12	454	213	290	¹
MS 1322 M	216	250	260	460	178	218	89	202	132	5	329	160	110	12	494	253	330	¹

1. 21 for motor supply, + PE of 9 and of 7 depending on options used, spread over 3 sides of the TB.

Type	(FF) plain hole flange							(FT) tapped hole flange							Shaft end					
	LB	M	N J6	P	LA	S	T	LB	M	N J6	P	LA	S	T	D J6	E	F	GA	O	Z
MS 1122 M	462	215	180	250	12	15	4	420	165	130	200	-	M10	3.5	28	60	8	31	M10	22
MS 1322 S	501	265	230	300	14	15	4	454	215	180	250	-	M12	4	38	80	10	41	M12	28
MS 1322 M	544	265	230	300	14	15	4	494	215	180	250	-	M12	4	38	80	10	41	M12	28

Open continuous current (DC) motors MS 1 - MS 2

Dimensions

Dimensions of options for MS open continuous current (dc) motors
Foot, flange or foot and flange mounted

Dimensions in millimetres

-Tachometric dynamos

MS 801, 1001, 1121 and 1321

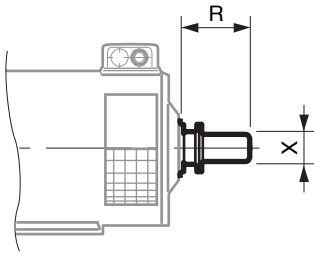

MS 1122 and 1322

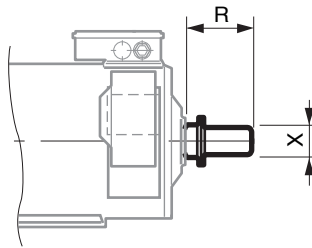

Reinforced tachometric dynamo

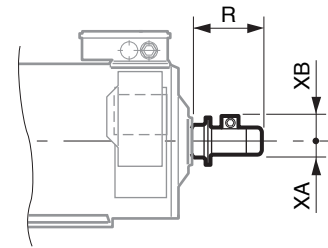

Type	REO 444N (normal)				REO 444R (reinforced)						RDC 15 (hollow shaft)	
	1 commutator		2 commutators		1 commutator			2 commutators			1 commutator	
	R	X	R	X	R	XA	XB	R	XA	XB	R	X
MS 801	159	75	175	75	169	45	72.5	188	45	72.5	-	-
MS 1001	158	75	174	75	168	45	72.5	187	45	72.5	-	-
MS 1121	158	75	174	75	168	45	72.5	187	45	72.5	-	-
MS 1122	157	75	173	75	167	45	72.5	186	45	72.5	43	98
MS 1321	158	75	174	75	168	45	72.5	187	45	72.5	-	-
MS 1322	159	75	175	75	169	45	72.5	188	45	72.5	51	98

- Tachometric dynamos and brake

MS 1122 and 1322

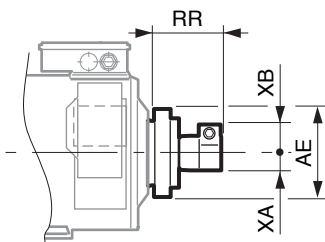

Type	REO 444N (normal) ¹				REO 444R (reinforced)							
	1 commutator		2 commutators		1 commutator				2 commutators			
	AE	RR	AE	RR	AE	RR	XA	XB	AE	RR	XA	XB
MS 1122	162	226	162	242	162	236	45	72.5	162	181	45	75
MS 1322	204	240	204	256	204	250	45	72.5	204	223	45	75

¹. End X : see table and figure MS 1122 and 1322 at the top of the page.

Type	RDC 15 (hollow shaft)			TD3 (hollow shaft)				KTD3 (hollow shaft)			
	1 commutator			1 commutator				1 commutator			
	AE	RR	X ¹	AE	RR	XA	XB	AE	RR	XA	XB
MS 1122	162	103	98	162	71	50	52	162	91	50	70
MS 1322	204	132	98	204	90	50	52	204	109	50	70

¹. See figure MS 1122 and 1322 at the top of the page.

N. B. : dimensions given for Radio Energie (REO) or Thalheim (TD & KTD) brands. Equivalent dynamos of different brands may be supplied depending on stocks available.

Open continuous current (DC) motors MS 2

Dimensions

Dimensions of options for MS 1122 and 1322 open continuous current (dc) motors
Foot, flange or foot and flange mounted

Dimensions in millimetres

- Air filter

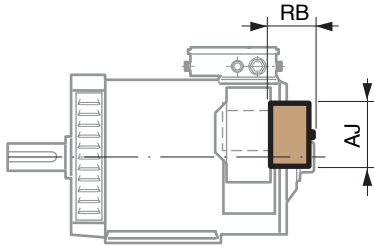

Type	Filter	
	AJ	RB
MS 1122	Ø 142	80
MS 1322	Ø 142	80

- Brake

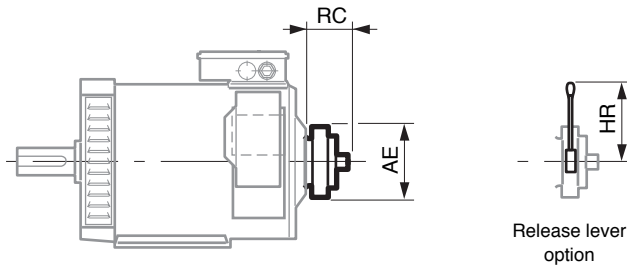

Type	Type 458 ¹		
	AE	HR	RC max
MS 1122	162	146	70
MS 1322	204	196	85

¹ See tachometric dynamos dimensions page B4.14.
Dimensions given for type 458. Depending on stocks available, equivalent types may be supplied.

- Second shaft end

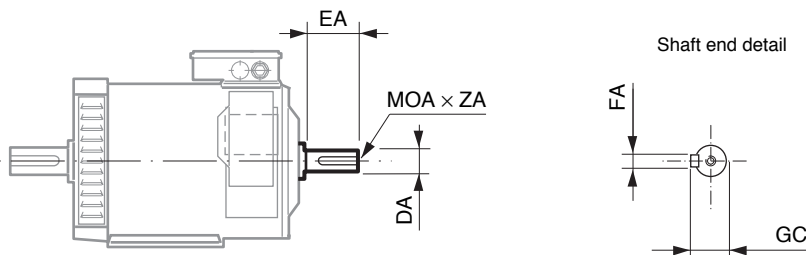

Type	Shaft end					
	DA	EA	FA	GC	OA ¹	ZA
MS 1122	19 j6	40	6	21.5	M6	16
MS 1322	22 j6	50	6	24.5	M8	19

¹ According to standard DIN 332.

