

Electronic drives for direct current motors VE/B - VE/RG

General information



VE/B

The VE/B are IP20, single phase unidirectional variable speed drives operating in quadrants 1 or 3 from the torque / speed diagram (mixed bridge diodes / thyristors). Their compactness and ease of operation without associated programming, allows most of the applications within the fractional horsepower motor market to be satisfied. They are adapted for both the MFA range of permanent magnet dc motors or the MS series of separately excited machines. They can operate by regulation of armature voltage or by closed loop speed (tacho-generator feedback). These drives are protected against overvoltages by resistance / capacitance circuits and by chopping (VE/B), and against the overcurrent by current limitation. Demagnetization of the motor magnets is therefore avoided on start up or during an overload condition.

VE/RG

The VE/RG is an IP 20, single phase reversible variable speed drives. Its full bridge with four thyristors allows operation in all four quadrants of the torque / speed diagram. It provides excellent control of the motor (it maintains a torque in both directions of rotation) attaining close to servo-motor performance. Its compactness and ease of operation without associated programming, allows most of the applications within the fractional horsepower motor market to be satisfied. It is adapted for the MFA series of permanent magnet dc motors and can operate in regulation of armature voltage or by closed loop speed (tacho-generator feedback). Inputs/outputs allow operation by regulation of torque. The drives are protected against over voltage by resistance / capacitance circuits and by chopping and against the overcurrent by current limitation. Demagnetization of the motor magnets is therefore avoided on start up or during an overload condition.

Torque / speed diagram

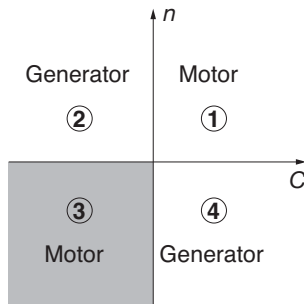

Operating chart VE/B

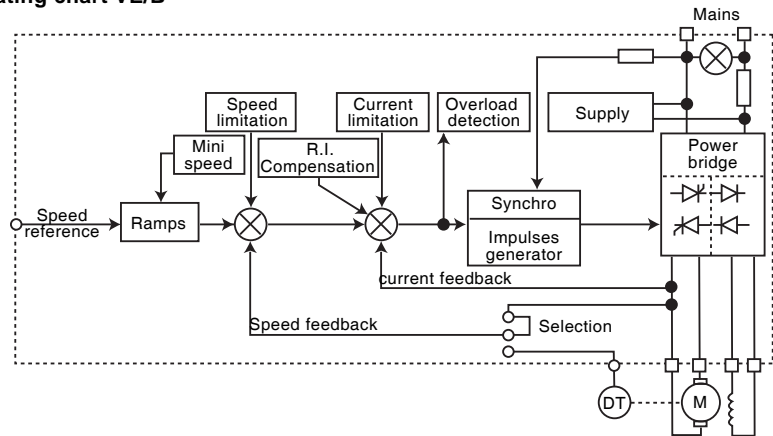

Operating chart VE/RG

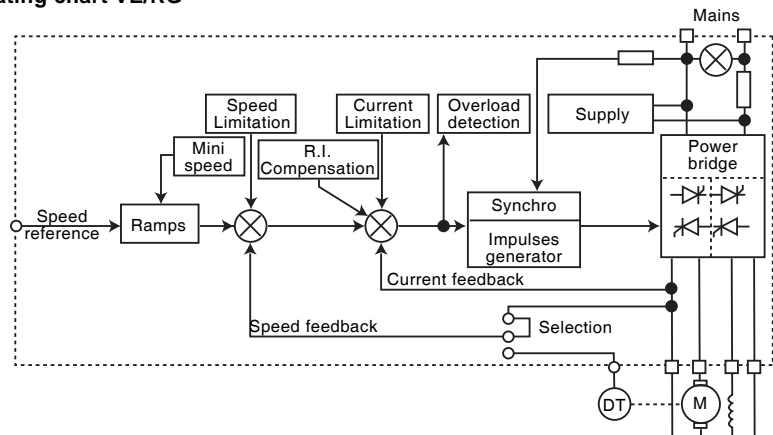

Electronic drives for direct current motors VE/B - VE/RG

Mounting positions

Electronic drive VE/B - VE/RG

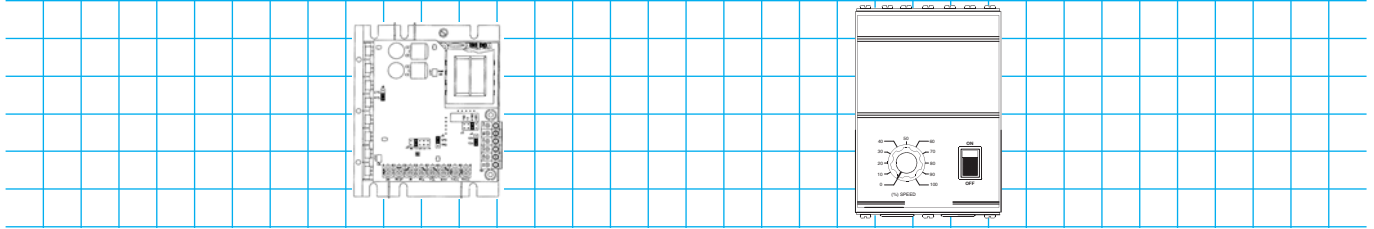

Only possibility

VE/B IP 20
VE/RG IP 20

VE/B IP 40



Electronic drives for direct current motors VE/B

Adaptation possibilities

For applications not specified in the selection charts, please consult the Leroy-Somer technical specialists.

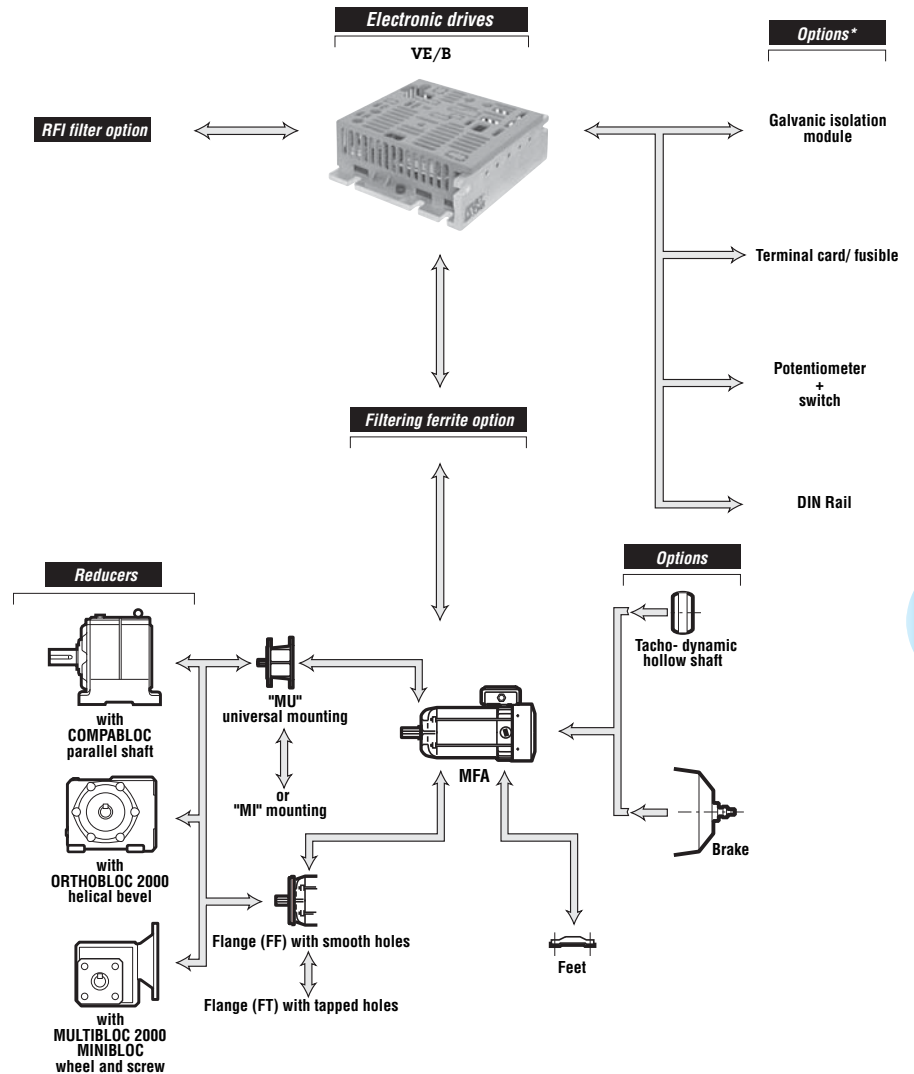

Designation / Coding

VE/B	12	IP 20
Type	Rating Power of ± 10	Protection indication

Example of coding :
Single-phase, reversible drive,
for motor 120 w
Designation
VE/B 12 IP 20

Code
-

All the products from this catalogue have a code.
The coding table is incorporated in the price list with the list of designations.

Electronic drives for direct current motors VE/RG

Adaptation possibilities

For applications not specified in the selection charts, please consult Leroy-Somer technical specialists.

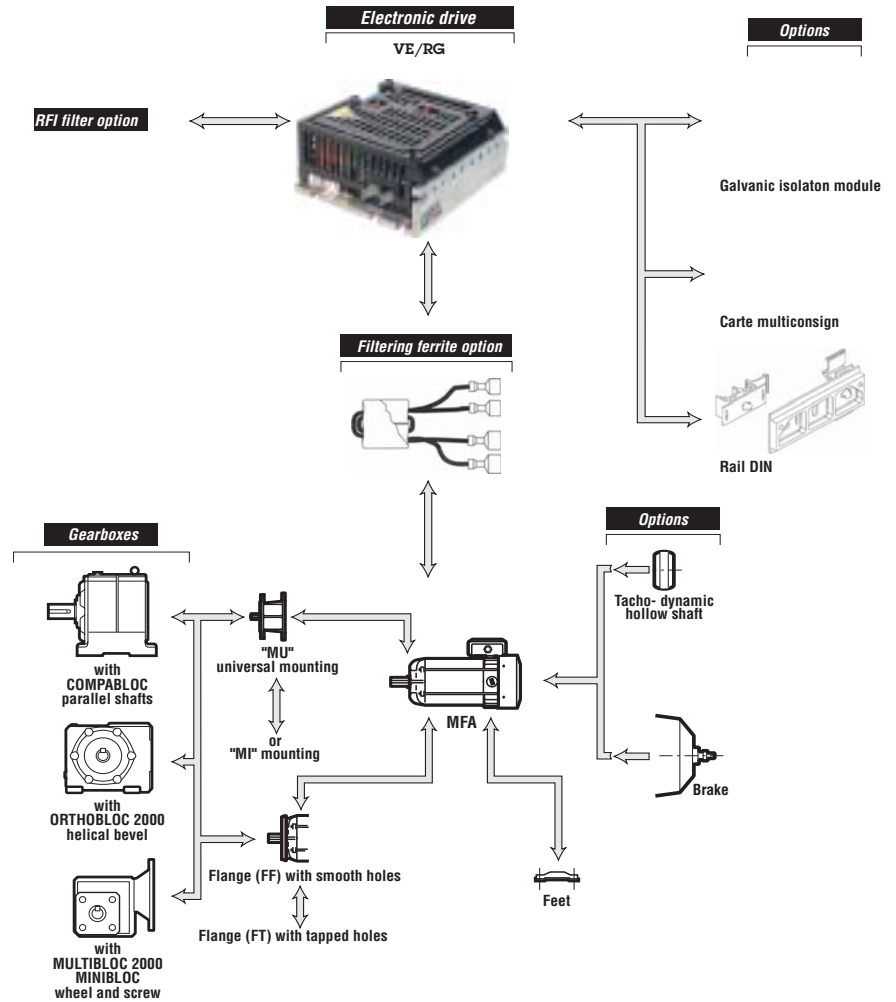

Designation / Coding

VE/RG	25	IP 20
Type	Rating Power of ± 10	Protection index

Example of coding :
Reversible, single-phase drive
for motor 250 w
Designation
VE/RG 25 IP 20

Code
-

All the products from this catalogue are coded.
The coding table is incorporated in the price list with the list of designations.

Electronic drives for direct current motors VE/B - VE/RG

Control circuit and functions

General information	VE/B	VE/RG
• 1 quadrant drive, 1 direction of rotation, comprises a mixed bridge (2 thyristors and 2 diodes)	●	
• 4 quadrants drives, comprising of a full bridge with thyristors		●
• Speed range : ratio	1 to 30	1 to 50
• Possibility of having either voltage or in torque command.	□	●
• Speed regulation :		
- input no load and full load : 1 % from rated speed	●	●
- for a mains variation $\pm 10\%$: 0.5 % from rated speed	●	●
- linearity of speed regulation as % of the rated speed	2 %	0.5 %
• Allowable overload : 150 % of the rated current- visualization of overload mode	●	●
• Compensation of the motor ohmic drop (R.I.)	●	●
• Protection against the driven load	□	●
• Protection against mains overvoltage by a varistor	●	●
Pilot control		
• Input Run/ Stop :		
- by run ocommand through dry, insulated n/o contact	●	●
- stop mode with free wheel or regeneration	□	●
• Input command non galvanically isolated:		
- for potentiometer 4.7 or 10 k Ω (5 k Ω provided)	●	●
- analogue through voltage (0 V = stop) V DC	0 - 10 V	± 10 V
• Possible tachogenerator feedback :		
- for generator 7 V DC - 1000 min ⁻¹	●	●
- for generator 20-30 V - 1000 min ⁻¹	□	□
- for generator or rectified alternator 50 V DC - 1000 min ⁻¹	●	●
Regulation		
• Maxi speed: from 50 to 110 % of rated speed	●	●
• Min. speed: in % of rated speed	0 to 30 %	□
• Ramps :		
- acceleration : from 0.5 to 10 seconds	●	□
- deceleration : from 2 to 10 seconds	●	□
• Acceleration ramp from 0.1 to 15 seconds	□	●
• RI Compensation	●	●
• Outside range order to stop mode	□	●
• Dynamic response	□	●
Signalling		
• Light emitting diodes		
- LED under voltage indication	●	●
- LED limitation	●	●

- : predicted
□ : unpredicted

Electronic drives for direct current motors VE/B - VE/RG

Selection

Electronic drives for direct current (dc) motors VE/B - Control via terminal block

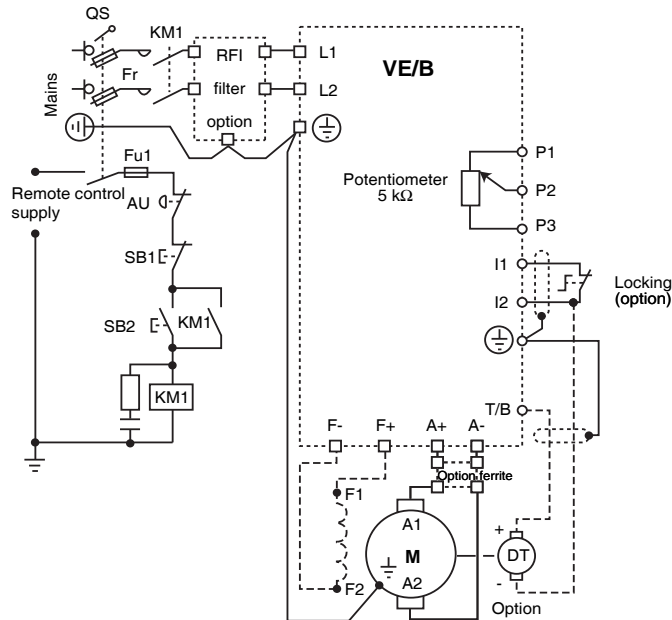

Electronic drives for direct current (dc) motors VE/RG - Control via terminal block

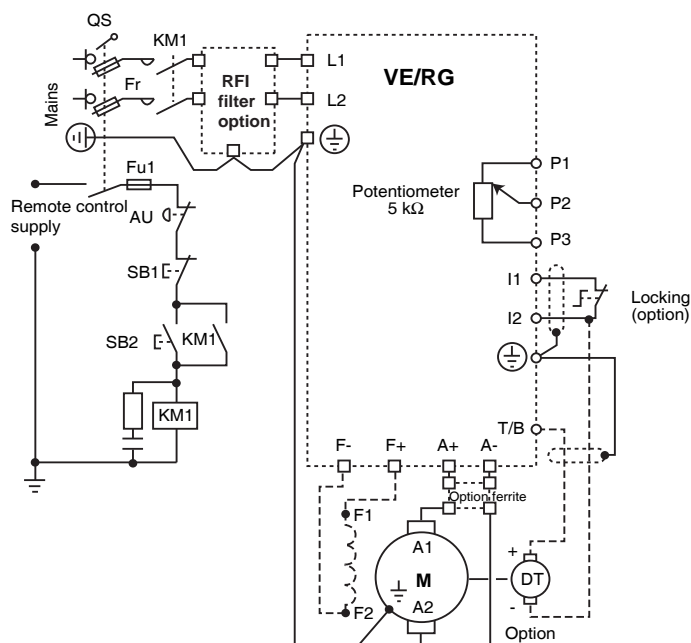

Electronic drives for direct current motors VE/B - VE/RG

Selection

IP 20 drives - Supply in single phase 230 V¹
Ambient temperature ≤ 40°C - Altitude ≤ 1000 m

Type	Mains	Armature voltage	Power	Rated current	
	I A	V _{DC}	kW	I _N A	I _{lim} A
VE/B - VE/RG 7	1.1	0 to ±180	0.075	0.75	1
VE/B - VE/RG 12	2	0 to ±180	0.12	1.2	1.5
VE/B - VE/RG 18	2.4	0 to ±180	0.18	1.5	2.1
VE/B - VE/RG 25	3.5	0 to ±180	0.25	2.1	3
VE/B - VE/RG 37	4.3	0 to ±180	0.37	2.9	3.6

1. VE/RG delivered in 115 V on request.

Additional drives

Options		VE/B		VE/RG
		IP 40	IP 20	IP 20
• RFI Filter VE class B	RFI B VE	●	●	●
• Filtering ferrite	SELFIL	●	●	●
• Mod. galvanic isolation VE/B ¹	IG VE/B	□	●	□
• Mod. galvanic isolation VE/RG	IG VE/RG	□	□	●
• Mounting Kit DIN rail	KIT DIN VE	□	●	●
• Mod. Multi-commandes	MC VE/RG	□	□	●
• Terminal card/ fuses ¹	CBF VE/B	□	●	□
• Potentiometer 1 tour 10 kOhms	KIT POT 1T 10K	□	●	●
• Potentiometer 10 turns 10 kOhms	KIT POT 10T 10 K	●	●	●
• Potentiometer + switch Kit	POT+I VE	●	●	●

1. With these options, le VE/B IP 20 becomes IP 00.

● : predicted

□ : unpredicted

Electronic drives for direct current motors VE/B - VE/RG

Dimensions

Dimensions for single phase drives VE/B - VE/RG

Dimensions in millimetres

VE/B

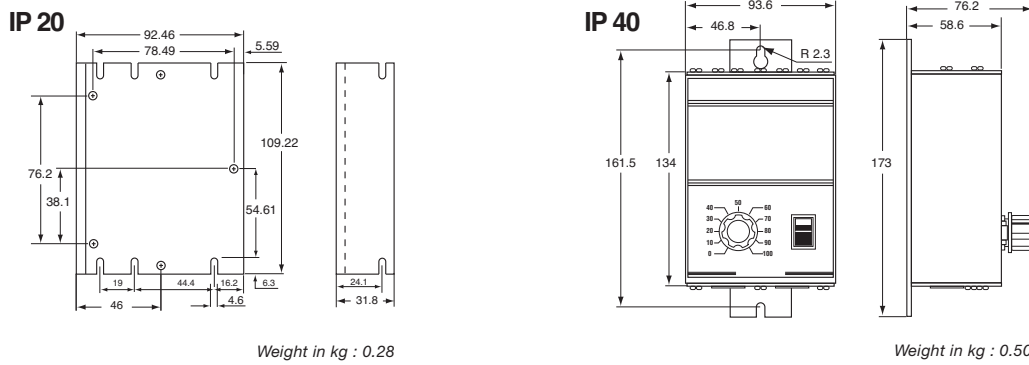

VE/RG

