

DMV 2322 / DMV 2342 **Three-phase controllers** **for D.C. motors** **Installation and maintenance**

Three-phase controllers DMV 2322 / DMV 2342

FOREWORD

This technical booklet describes the installation of the **DMV 2322 / DMV 2342** DC digital controller. It describes the relevant procedures required when servicing the controller and the possible peripheral devices.

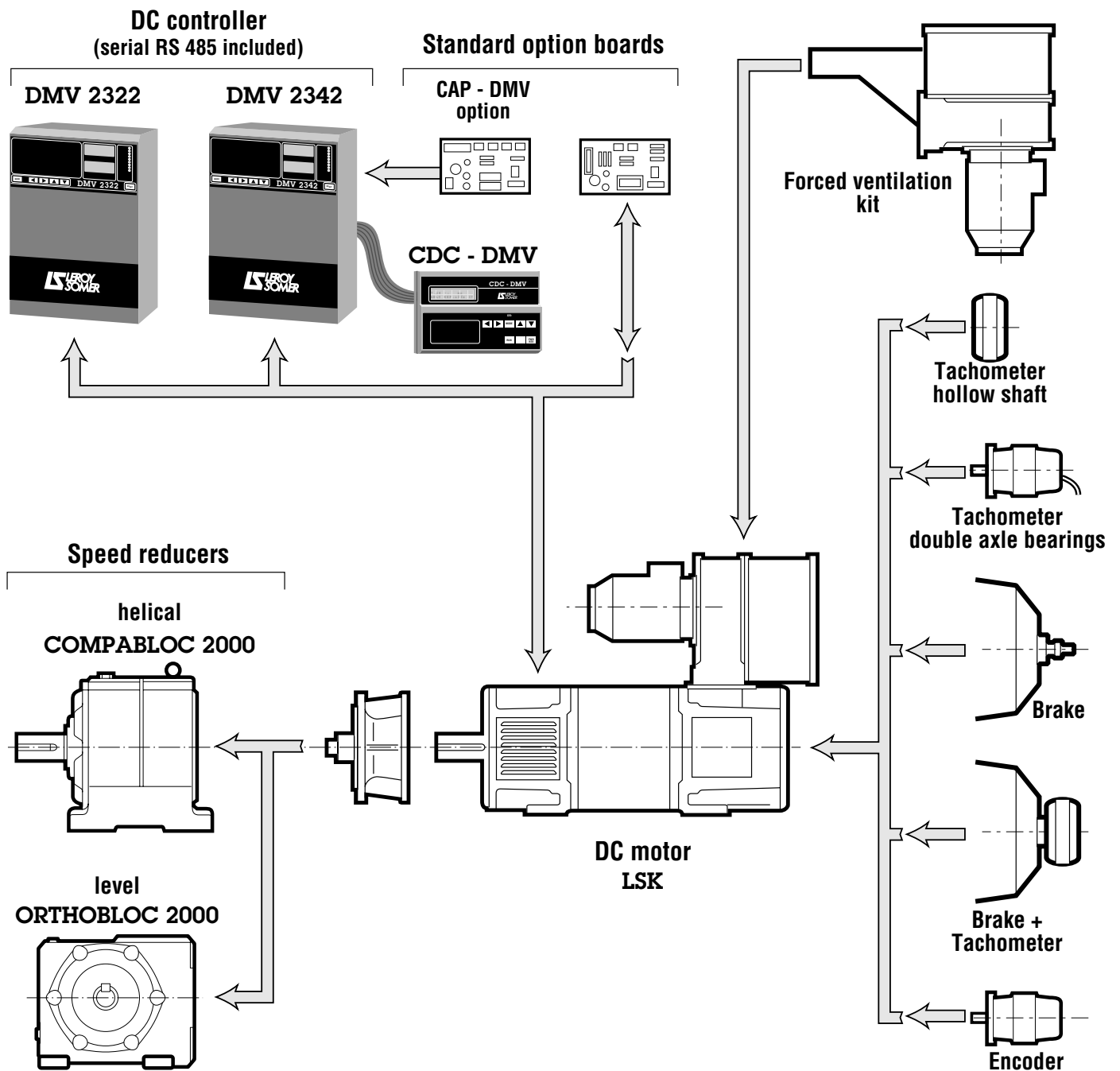

Three-phase controllers DMV 2322 / DMV 2342

1 - GENERAL INFORMATIONS

1.1 - Principles of the variable speed drive with DMV 2322 / DMV 2342 controllers

DMV 2322 / DMV 2342 is the latest family of advanced, fully microprocessor-controlled dc variable speed industrial drives. The range of output current is from 25A to 1850A. All sizes share control, monitoring, protection and serial communications features.

All modules are available alternatively in either " single-ended " or " four-quadrant " configuration. Single-ended drives provide forward run operation only. Four-quadrant drives are fully-reversible. Both types offer comprehensive control of motor speed and/or torque, the four-quadrant drives providing full control in both directions of rotation.

Operating parameters are selected and changed either at the keypad or through the serial communications link. Access for writing or changing parameter values can be protected by the three-level security code system.

As an option, a separate intelligent keypad-display module is available, for local or remote mounting, which offers a versatile multi-lingual plain text user interface.

1.1.1 - DC motor control

The functions of a dc motor which must be controllable for practical use are the speed, the torque delivered, and the direction of rotation. Speed is proportional to armature back-emf and inversely proportional to field flux. Torque is proportional to armature current and field flux. Direction of rotation is simply a matter of the relative polarities of the armature and field voltage. It follows that it is necessary to control.

1. The armature voltage ; back-emf is a component of armature voltage. Thus, assuming the field to be constant, control of armature voltage provides complete control of speed up to the point where the voltage reaches the maximum value for which the armature is designed. Armature current is also a function of armature voltage, so that within the speed range up to maximum voltage, torque is controlled by voltage also. Provided that the field is fully-excited, the availability of maximum torque is normally maintained from zero speed up to armature voltage maximum (base speed).

2. The field voltage ; this determines the field current and, in consequence, field flux. If field voltage can be varied independently of the armature voltage, speed can be increased at full power (full armature voltage) beyond the point where the applied armature voltage and current are at maximum. Since torque is directly proportional to field flux, maximum torque is reduced if speed is increased by weakening the field.

Basically, therefore, a variable speed dc drive is a means of controlling the voltage applied to the armature of the motor, and thus the current delivered to the motor. The drive may be equipped with means for optional control of the field if speeds higher than base speed are required. Separate control of the field within the operating range up to base speed can be exploited also, to obtain extended control of speed and torque for more-complex motor applications. If a suitable feedback is available, position control becomes possible.

If the motor application is such that it demands complete control of motor operation in both directions, with the ability to reverse motor torque rapidly and frequently, two anti-parallel bridges must be used. This configuration enables full control of forward and reverse drive and forward and reverse braking and is called " four-quadrant ".

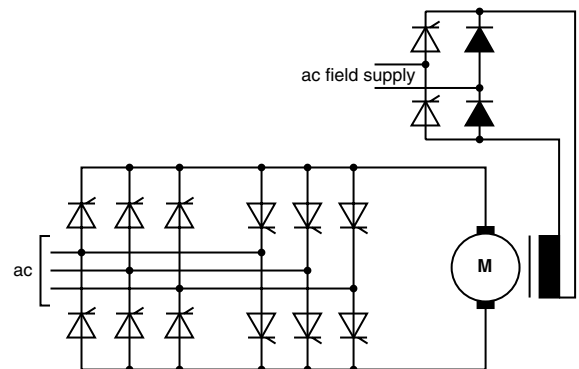

Dual-bridge or parallel-pair thyristor stack, arrangement for a 4-quadrant dc motor drive.

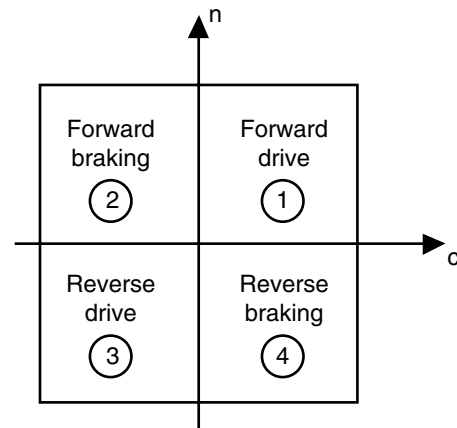

n : speed.
c : torque.

The four quadrants of the dc motor torque-speed diagram.

Three-phase controllers DMV 2322 / DMV 2342

DMV 2322 and DMV 2342 synoptic

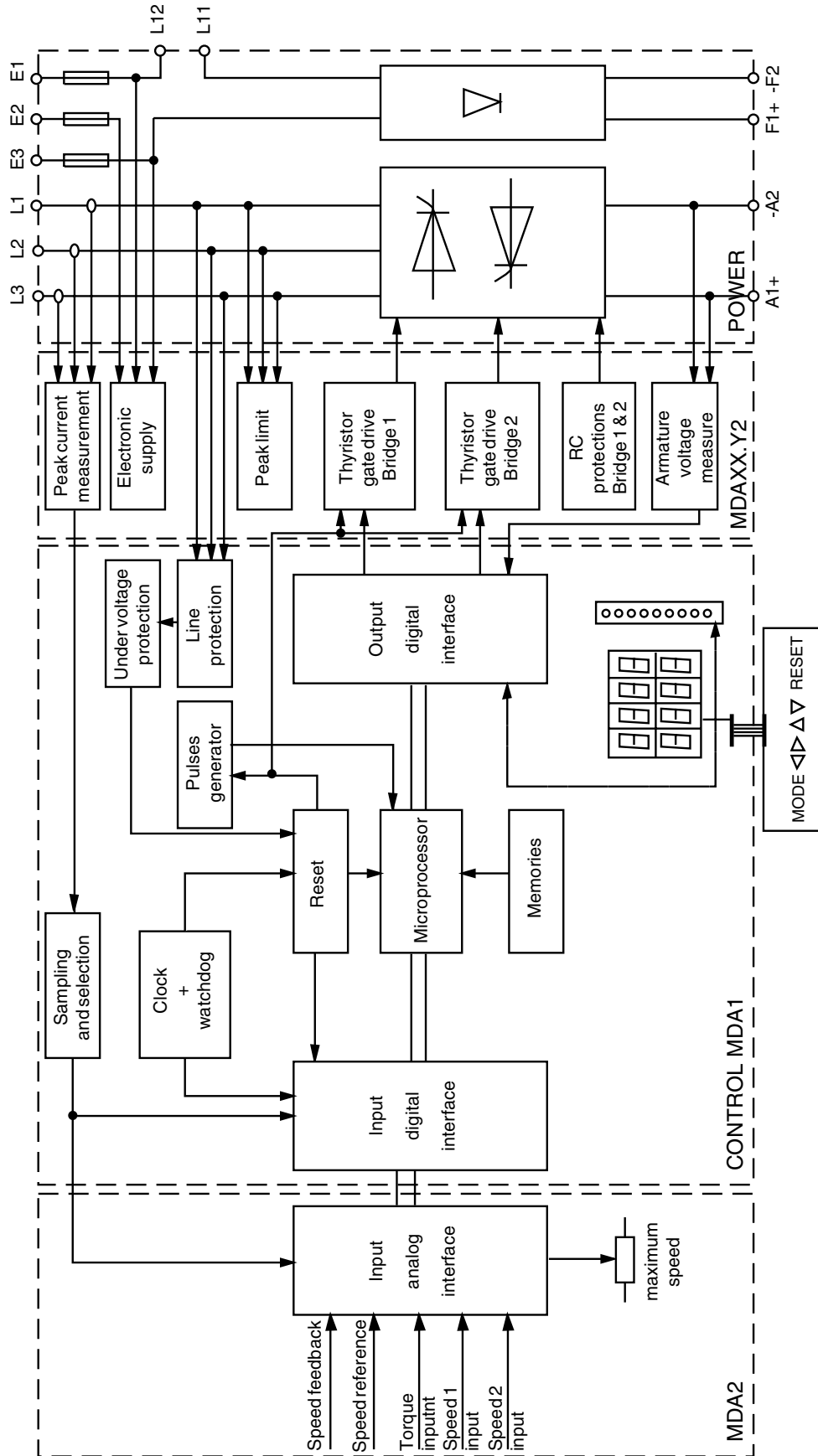

Three-phase controllers

DMV 2322 / DMV 2342

Control

Regardless of whether a drive is single or four-quadrant, motor response is fundamentally a function of voltage output, which is a function of the firing angle of the thyristor bridge, and this can be controlled precisely.

The quality of the response obtained from the motor is, therefore, dependent on the ability of the drive logic to receive, interpret and process a complete range of data concerning the state of the motor, and the desired state. Some of this data may be from external sources, such as the speed reference (demand), torque reference, motor speed feed-back, and so on ; some are derived internally by the drive logic itself, for example, output voltage and current, and the demand condition of the logic system at various stages.

The logic system requires a set of instructions to enable it to undertake the process of interrogation, processing and signal-generation to control thyristor firing. The instructions are provided in the form of data broken down into individual values or " parameters " for the user to provide in accordance with the particular operations required for the motor application. The behaviour of the drive in terms of any given industrial application is a function of the information it receives for processing from user-written and internally-monitored parameter values.

For this reason, the **DMV 2322 / DMV 2342** drive is equipped with a dedicated microprocessor, and with software which is configured by the parameters written to it by the user. The parameters cover every significant factor related to motor performance, so that the user can set the drive up to meet the application requirements exactly. Further parameters are provided for communications, security and other operational functions.

1.1.2 - Menus

The number of parameters is large, but understanding of them and access to them have been greatly facilitated by arranging them in menus, each menu covering a particular logical or functional grouping. An overview of the control logic system of the drive will be found in chapter 3 with a graphical representation of each individual menu, in a set of logic diagrams.

1.1.3 - Serial communications

The serial communications link with which the **DMV 2322 / DMV 2342** drive is equipped is a significant feature in relation to operation within an industrial process application. For example, external programmable process logic controllers (PLCs) can be set up with access to the whole or part of the drive logic, enabling the setting of parameters to be changed, virtually instantaneously, to suit different stages of a duty cycle or different operating conditions in the process.

The serial communications facility also provides for the operation of the drive to be continuously monitored for control or analytical purposes.

1.2 - Rating label

Example : **DMV 2342 - 75**

DMV Controller family appellation

2 Digital technology

3 Three-phases

4 2 : 2 Quadrants

4 : 4 Quadrants

2 Version

75 Rating in Amps.

.

.

.

Up to 1850A.

This appellation is reproduced on the nameplate in the type area.

DV 91 548		ENTREE - INPUT		SORTIE - OUTPUT	
		PUISSANCE POWER		/	
		TENSION VOLTAGE		220/480 V 230/500 V	
Z3563		TYPE TYPE		Ph -Hz 3 Ph 50/60 Hz / Ph / Hz	
DMV 2342 - 75		INTENSITE CURRENT		60 A 75 A	
PUISSANCE MAX. MOTEUR MAX. MOTOR POWER		Exc/Field : 5A max			
/ KW		N°			

In order to answer to the multi-voltage criterium, the areas are not completed.

Three-phase controllers DMV 2322 / DMV 2342

1.3 - Main features

Nota : The main specifications are valid for both DMV 2322 and DMV 2342 except particular comments.

Input power voltage supply	220V to 480V +10%.													
Input electronic voltage supply	220 to 480V \pm 10%.													
Supply voltage	240	400	415	440	460	480								
Maximum field voltage	210	360	370	400	415	430								
Armature voltage	2 Quadrants DMV 2322	260	440	460	500	510	530							
	4 Quadrants DMV 2342	260	440	460	500	510	530							
Supply frequency	45Hz to 62Hz self adapting.													
Type - current (A) rating	25	45	75	105	155	210	350	420	550	700	825	900	1200	1850
Maximum continuous current rating AC	21	38	60	88	130	175	292	350	460	585	690	750	1000	1540
Maximum continuous current rating DC	25	45	75	105	155	210	350	420	550	700	825	900	1200	1850
Typical kW rating (400V armature)	7.5	15	30	37.5	56	75	125	150	200	250	300	340	450	750
Maximum field current (A)	8				10				20					
Regulated field current as standard	Yes				No				No					
Field weakening as standard	Yes				No				No					
Regulated field \leq 20A + field weakening with external option	Yes				No				No					
Protection enclosure	IP00													
Operation at ambient temperature	0 to +40°C (maximum + 55°C).													
Altitude	1000m.													
Speed reference	<ul style="list-style-type: none"> • Digital signal by encoder • Voltage signal : 0 to \pm10V - 10mA • Current signal : 0 - 20mA or 20mA - 0 4 - 20mA or 20 - 4mA. 													
Speed reference potentiometer	Recommended : 2,2 k Ω to 10 k Ω - 2W													
Speed feedback	<ul style="list-style-type: none"> • Tacho maximum voltage : 300V. • Armature voltage : maximum 530V. • Encoder. 													
Zero speed relay	Maximum current : 5VDC - 5A or 250 VAC - 2,2A,													
Drive ready	110 VAC - 5A.													
Speed resolution	Reference		Feedback				Resolution							
	Analogue		Armature voltage				0,83 V							
	Analogue		D.T.				0,125 %							
	Digital		D.T.				0,1 %							
	Analogue		Encodeur				0,035 %							
	Digital		Encodeur				0,01 %							
Encodeur		Encodeur				Absolute								
Speed range	1 to 1/125													
Torque control	0,5 %													
Acceleration - Deceleration ramp	0 to 200s.													
External encoder supply	5V - 12V - 15V selectable - 300mA.													
Voltage output for external relay control	+24V - 200mA.													
Armature current limitation	150 % In for 30s.													
Digital inputs characteristics	TB3 and TB4 terminals : - active low U < +2V, - active high U > +4V.													
Digital outputs characteristics	TB2 terminals : - open collector outputs external supply : U max = 30V I max = 50 mA.													

Three-phase controllers DMV 2322 / DMV 2342

1.4 - Environment specifications

Storage temperature range : - 40°C to 55°C.
 Rated maximum ambient temperature : 40°C.
 Derating above 40°C : 1.5 % per 1°C.
 Humidity requirement : non-condensing.
 Rated maximum altitude : 1000m.
 Derating above 1000m : 1 % per 100m.

1.4.1 - Ventilation

The specifications are valid for both DMV 2322 and DMV 2342

Air flow in m³ min⁻¹.

Rating	Ventilation type	Airflow (m ³ min ⁻¹)
25	Natural	
45		
75		
105		
155		
210	Forced ventilation External supply : single phase 240V - 32W	5
350	Forced ventilation External supply : single phase 240V - 48W	7,6
420		
550	Forced ventilation External supply : Single phase 240V - 120W	17
700		
825		
900	Forced ventilation External supply : three phase 400V - 320W	20
1200		
1850		

1.4.2 - Losses at the rated current

DMV 2322 / DMV 2342 armature voltage 400V

Rating	25	45	75	105	155	210	350
Losses (W)	38	75	150	190	280	380	630
Rating	420	550	700	825	900	1200	1850
Losses (W)	750	1000	1300	1500	1700	2300	3800

DMV 2322 / DMV 2342 armature voltage 500V

Rating	25	45	75	105	155	210	350
Losses (W)	45	95	190	240	350	470	780
Rating	420	550	700	825	900	1200	1850
Losses (W)	940	1300	1600	1900	2100	2800	4700

1.5 - Weights - Dimensions

1.5.1 - Weights (kg)

Controller Rating	DMV 2322	DMV 2342
25	10	11
45		
75		
105	14	15
155		
210	21	21
350	22	23
420		
550		
700	27	30
825		
900	70	120
1200		
1850		

Three-phase controllers DMV 2322 / DMV 2342

1.5.2 - Dimensions DMV 2322 and DMV 2342

Dimensions in mm.

25 A to 75 A 105 A and 155 A

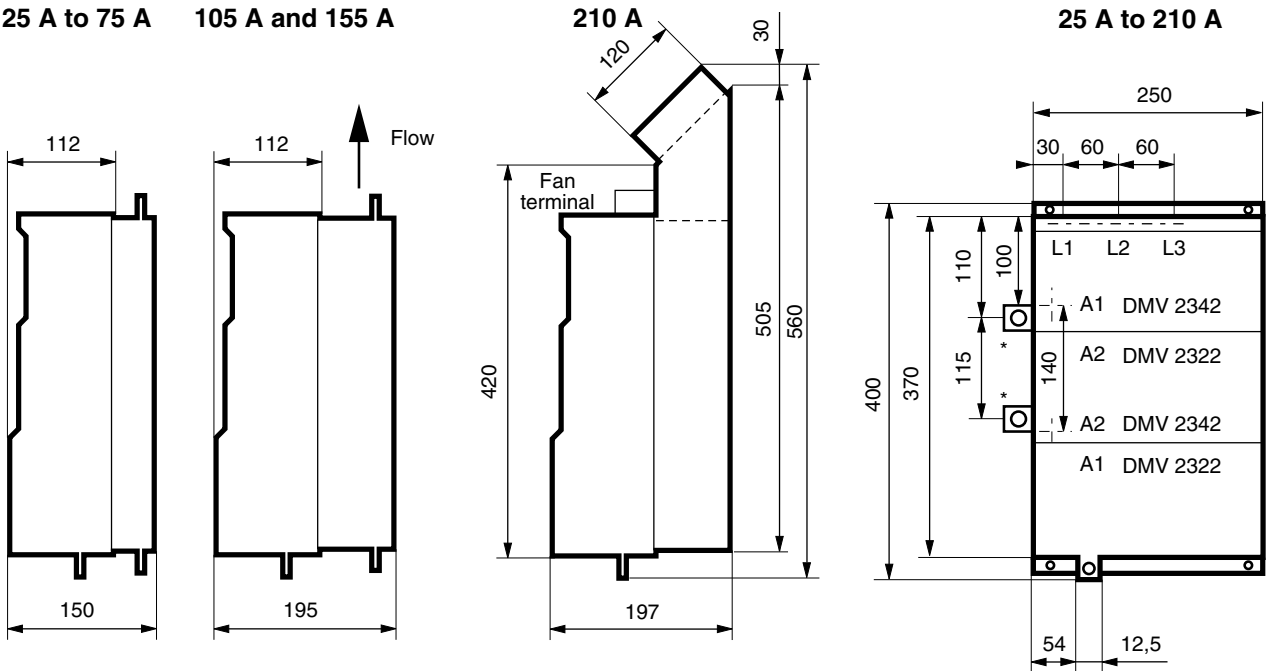

* : Only for DMV 2342 105A to 210A

350 A and 420 A

550 to 825 A

350 A to 825 A

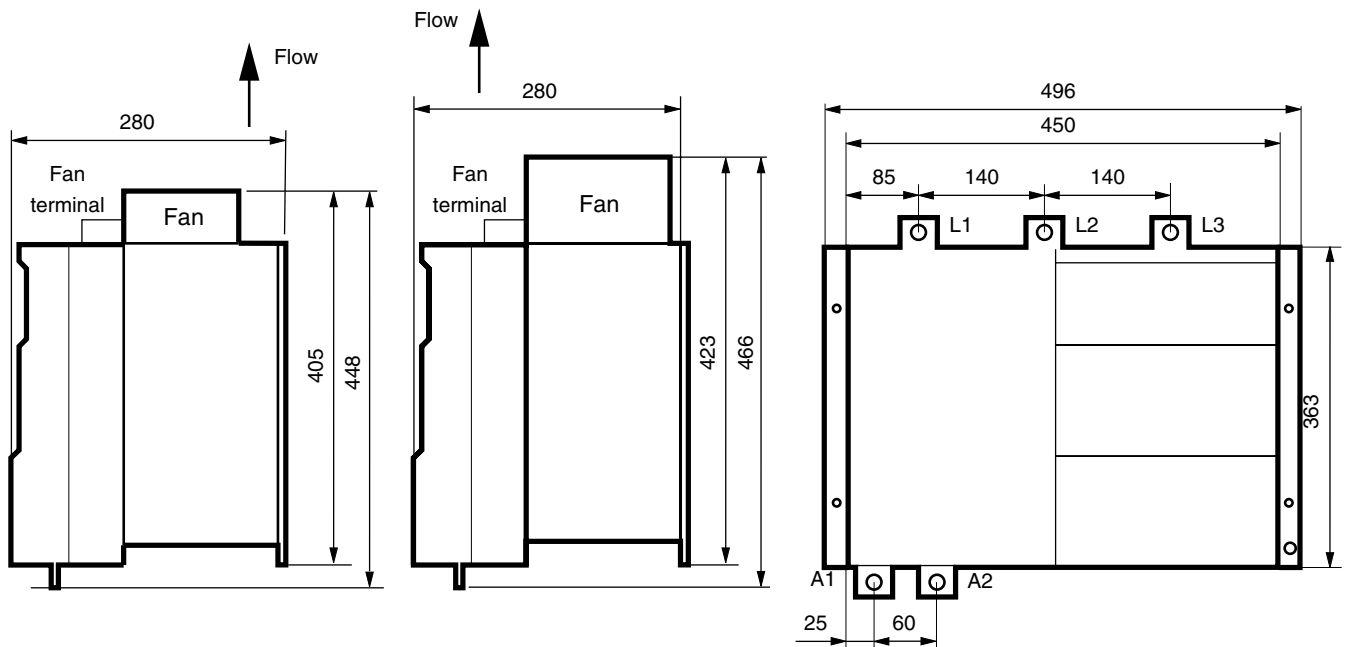

The different dimensions and weights are approximative. In the interests of a commitment to a policy of continuous development and improvement, the manufacturer reserves the right to change these characteristics.

Three-phase controllers DMV 2322 / DMV 2342

Dimensions in mm.

900 A to 1850 A

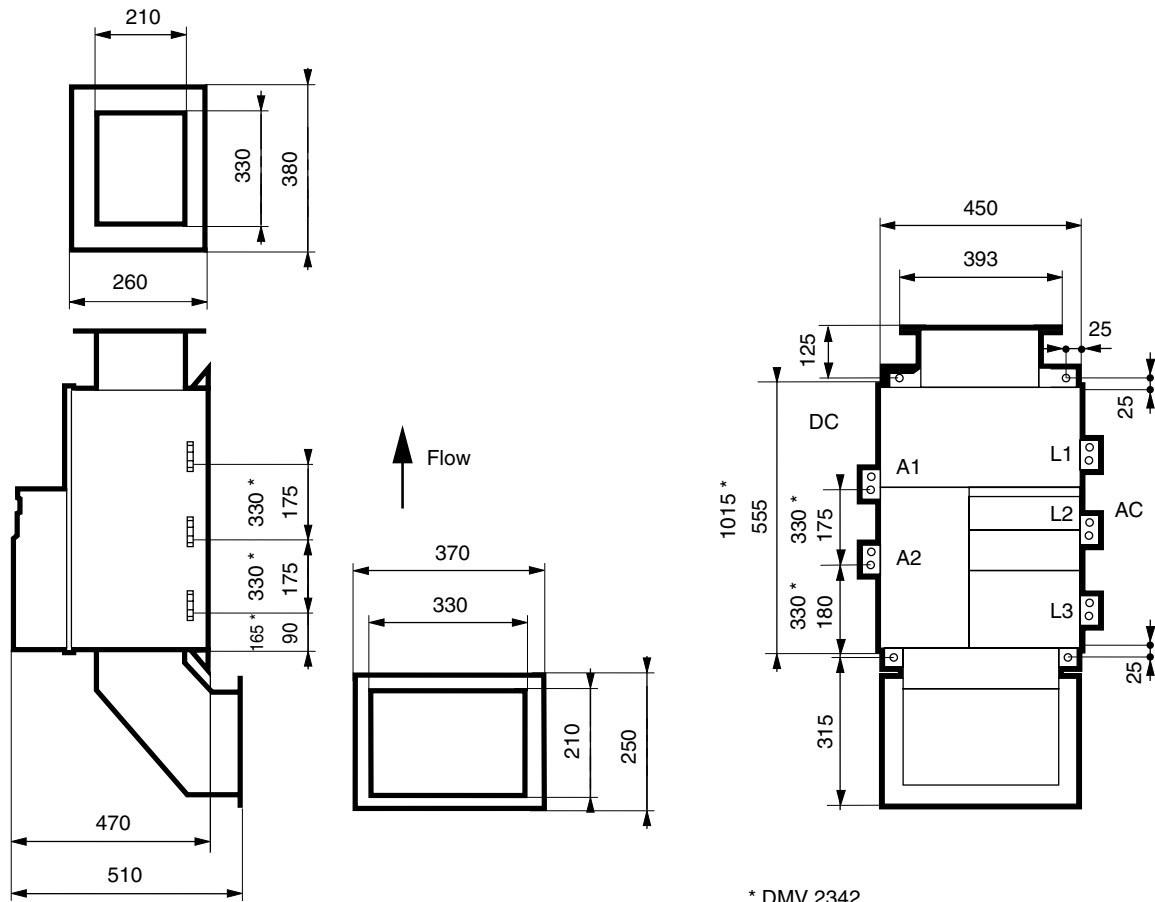

* DMV 2342

External forced ventilation : ratings 900A to 1850A

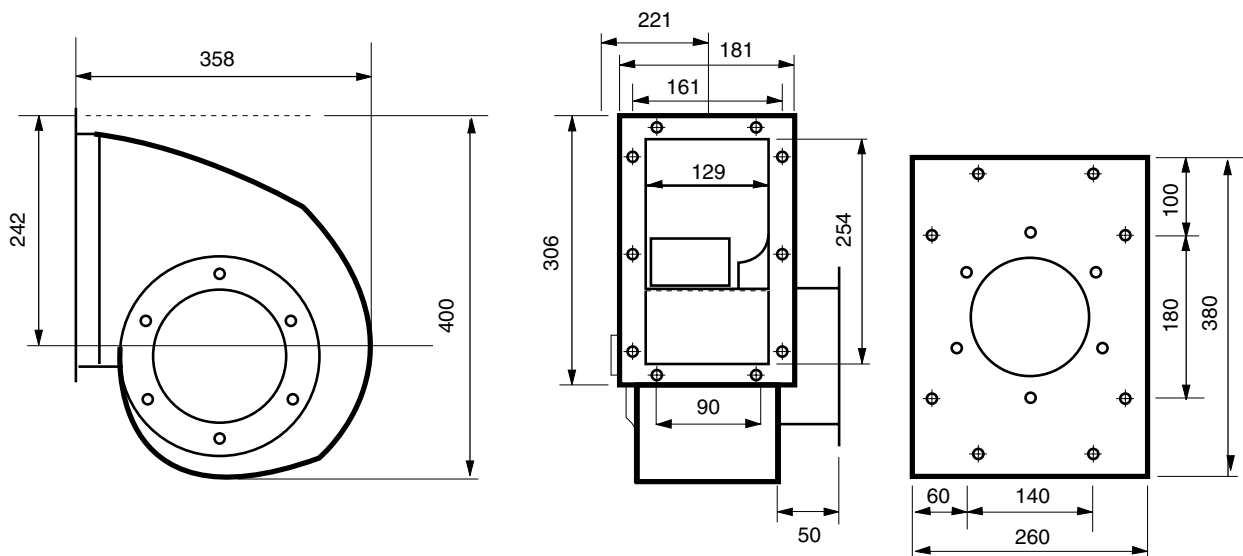

The different dimensions and weights are approximative. In the interests of a commitment to a policy of continuous development and improvement, the manufacturer reserves the right to change these characteristics.

Three-phase controllers DMV 2322 / DMV 2342

1.6 - Mounting

Location

The drive should be installed in a place free from dust, corrosive vapours and gases, and all liquids. Care must also be taken to avoid condensation of vaporised liquids, including atmospheric moisture.

If the drive is to be located where condensation is likely to occur when the drive is not in use, a suitable anti-condensation heater must be installed. The heater must be switched OFF when the drive is energised. An automatic changeover switching arrangement is recommended.

DMV 2322 / DMV 2342 drives are not to be installed in classified Hazardous Areas unless correctly mounted in an approved enclosure and certified.

Mounting and Cooling

There are certain variations across the **DMV 2322 / DMV 2342** range of drives, in respect of mounting and cooling arrangements. With most models there is the option of surface or through-panel mounting. The higher-rated drives require forced ventilation and can optionally be supplied complete with ducted cooling fans.

Alternatively, the installer may arrange to use separately-provided ducted cooling air. Air flow requirements are shown in the ventilation table 1.4.1.

Mounting diagrams

These diagrams are different in relation to the ratings, but are the same for DMV 2322 and DMV 2342 (except for the ratings 900A to 1850A).

• Rating 25 to 155A

2 brackets are delivered separately with the controller. These 2 brackets are fitted, top and bottom, to the heatsink.

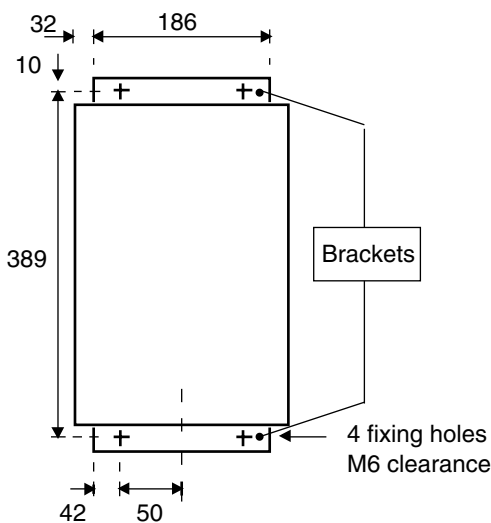

• Rating 210A

4 fixing holes M6 clearance on the rear panel.

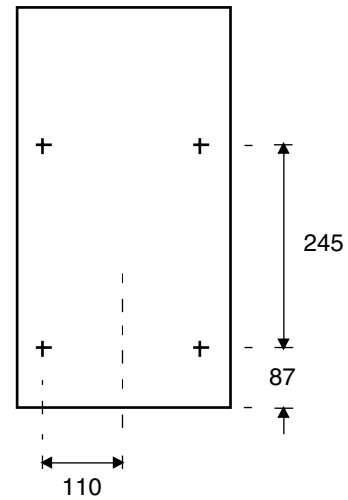

• Rating 350 to 825A

4 fixing holes M8 clearance on the rear panel.

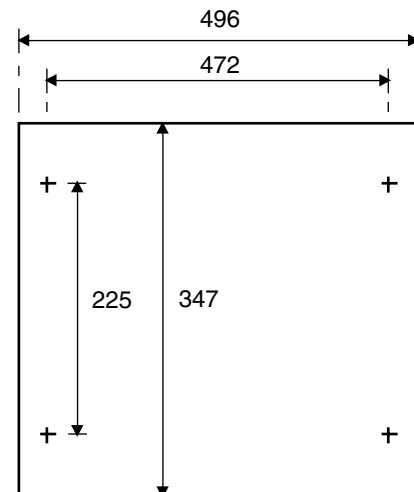

• Rating 900 to 1850A

4 fixing holes M10 clearance on the rear panel.

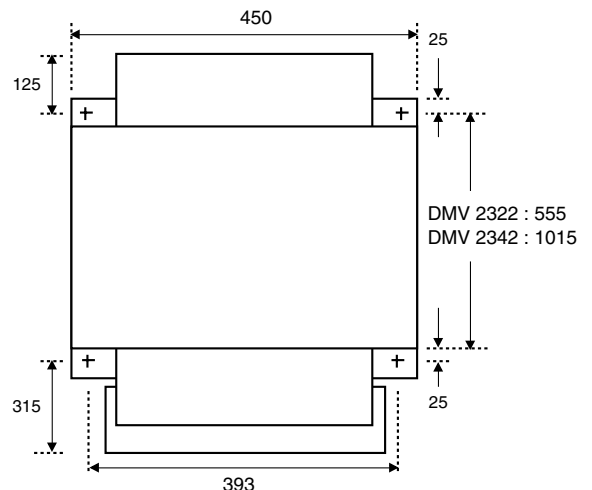

Three-phase controllers DMV 2322 / DMV 2342

2 - WIRING

Access to the control terminals, is gained by removing the lower part of the front cover.

Access to the power terminals of the smaller drive modules (up to 210A) is gained by opening the front cover, which is secured by two captive screws, one at each upper corner, and hinged at the bottom.

The higher - rated models have externally - accessible terminal lugs.

2.1 - Terminals index

2.1.1 - Power connections

a) General table

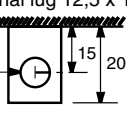
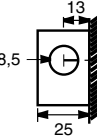
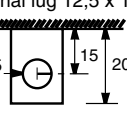
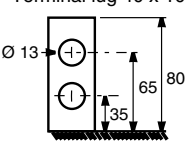
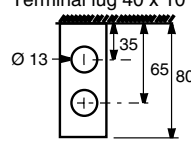
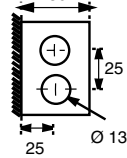
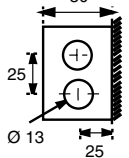
	Main L1, L2, L3	Armature A1, A2	Earth 	Field			Forced ventilation
				E1 - E2 - E3	F1 - F2	L11 - L12	
Description	AC input	DC output	Protection	Field and electronic supply	Field bridge output	Field ON - OFF	Fan supply
Voltage	Three-phase ≤ 480V 45 - 62 Hz	≤ 530 V	-	≤ 480V	≤ 430V	≤ 480V	240 or 400V see § 1.4.1
DMV 2322 25A to 210A and DMV 2342 25A to 75A	M8 bolt, located at the top of the modules	M8 bolt, located at the top of the modules	Terminal lug 12,5 x 1,5  at the bottom of the modules	Cruciform head screw terminal at the bottom of the modules			-
DMV 2342 105A to 210A	M8 bolt, located at the top of the modules	Terminal lug 30 x 6  at the left side of the modules	Terminal lug 12,5 x 1,5  at the bottom of the modules	Cruciform head screw terminal at the bottom of the modules			Split head screw terminal at the top of the modules (only 210A)
DMV 2322 and DMV 2342 350A to 825A	Terminal lug 40 x 10  at the top of the modules	Terminal lug 40 x 10  at the bottom of the modules	M8 bolt, located at the right side of the modules	Cruciform head screw terminal at the top of the modules	Cruciform head screw terminal at the bottom of the modules	Cruciform head screw terminal at the top of the modules	Split head screw terminal at the top of the modules
DMV 2322 and DMV 2342 900A to 1850A	Terminal lug 50 x 10  at the right side of the modules	Terminal lug 50 x 10  at the left side of the modules	M8 bolt, located at the right side of the modules	Cruciform head screw terminal at the top of the modules	Cruciform head screw terminal at the bottom of the modules	Cruciform head screw terminal at the top of the modules	Split head screw terminal in the connecting box of the Fan motor

Nota : The correct phase sequence is L1 - E1, L2 - E2, L3 - E3. The terminals L11, L12 provide for " Field OFF " switch.

Three-phase controllers DMV 2322 / DMV 2342

b) Standard field circuit

Rating DMV 2322 and DMV 2342	Field current	Field circuit	Field current regulation
25A to 210A	8	EXC - DMV 8 internal	Yes
350A to 825A	10	Internal diode rectifier	No
900A to 1850A	20	Internal diode rectifier	No

Electrical characteristics of the regulated field EXC - DMV 8.

Voltage E1 - E2 - E3	240	400	415	440	460	480
F1 - F2 maximum voltage	216	360	375	400	415	430
Motor field voltage possibilities	110 to 200	170 to 360	170 to 360	360	360	360
Field current	0 to 8 A adjustable					

Electrical characteristics of fixe diode rectifier (not regulated).

Voltage E1 - E2 - E3	240	400	415	440	460	480
F1 - F2 maximum voltage	216	360	375	400	415	430
Motor field voltage possibilities	170 to 200	340 to 360	Special field or auto- transformer to adapt the field voltage.			

• Recommended connections if the motor field voltage is compatible with the supply voltage.

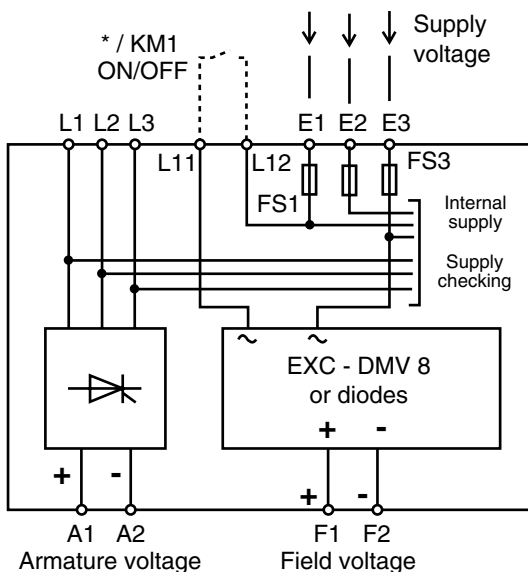

* KM1 : refer to 2.3.

• Recommended connections if the motor field voltage is not compatible with the supply voltage.
An auto-transformer will be used as shown below.

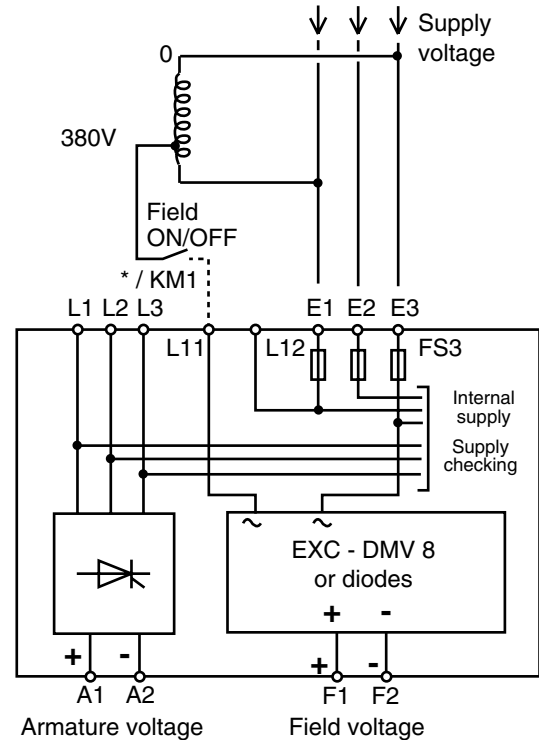

* Field wiring using an external field bridge EXC - DMV 20 for the ratings $\geq 350A$.

• With a compatible supply voltage.

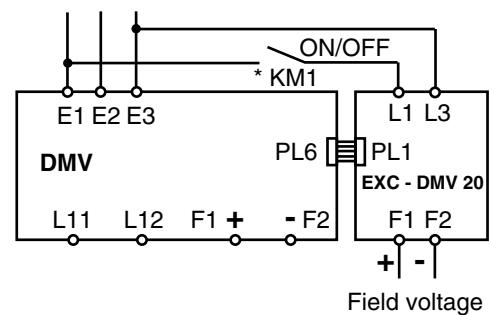

• With an auto-transformer.

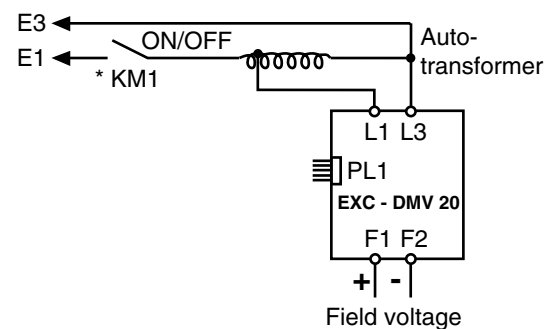

Three-phase controllers DMV 2322 / DMV 2342

2.1.2 - Control terminals

a) MDA2 interface

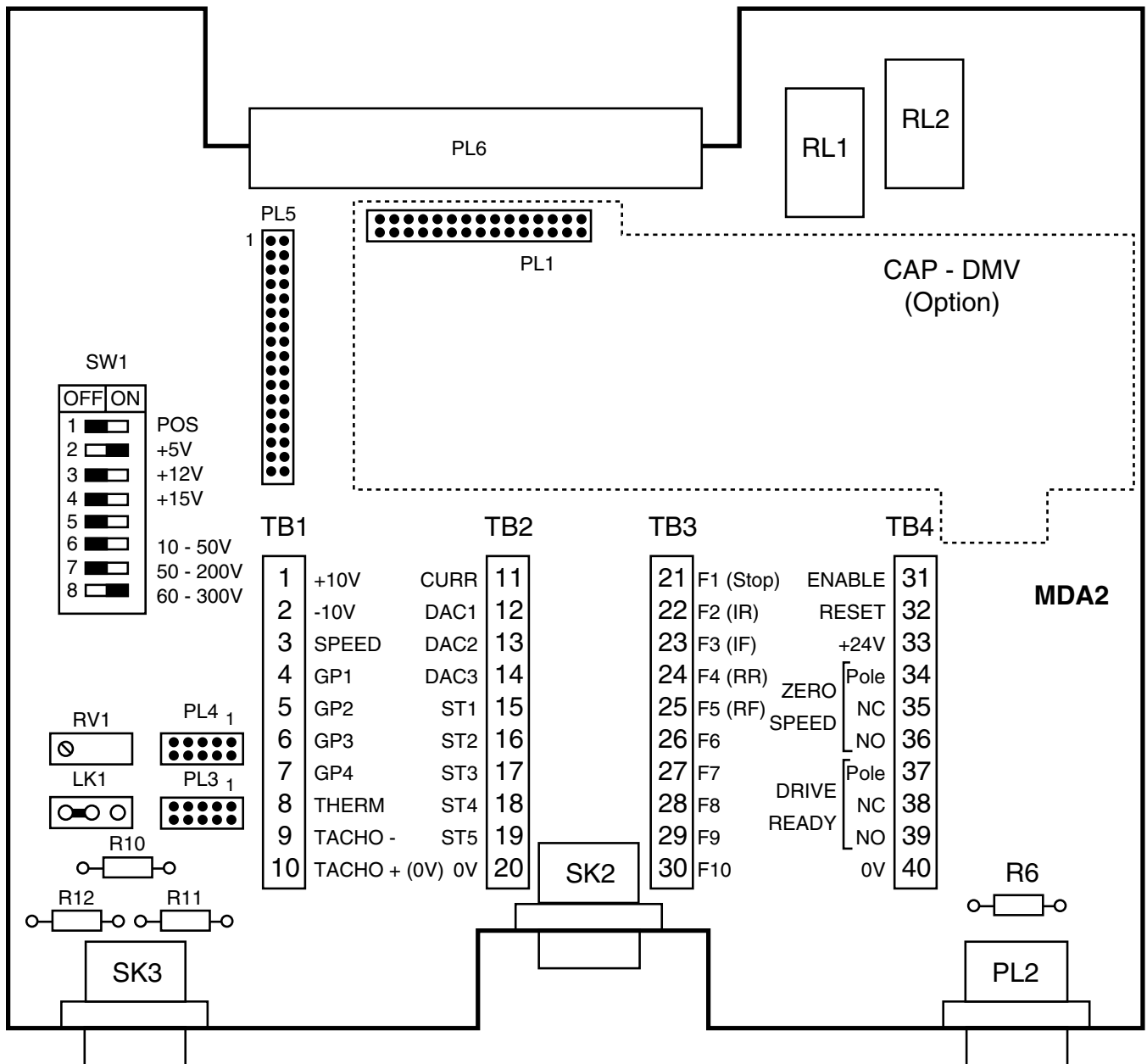

PL2 : 9-way D-type male socket for the RS 485 serial link

SK3 : 9-way D-type female socket for the speed feedback encoder

SK2 : 9-way D-type female socket for the CDC-DMV remote keypad

PL4 : 10-way header for the reference encoder

PL3 : 10-way header for the feedback encoder

PL5 : Informations transfert

PL6 : connection between MDA1 and MDA2

RV1 : tachogenerator feedback adjustment

SW1 1 : logic input polarity : positive/negative

SW1 2 :	} encoder supply voltage selectors	+5V
SW1 3 :		+12V
SW1 4 :		+15V
SW1 6 :		10 - 50V
SW1 7 :	} tachogenerator feedback ranges	50 - 200V
SW1 8 :		60 - 300V

Nota : PL3 is connected in parallel with SK3.

Three-phase controllers DMV 2322 / DMV 2342

b) Control terminals

The 4 terminal blocks are located on the MDA2 PCB.

- TB1** 1 to 10 - Analog inputs,
TB2 11 to 20 - Analog outputs,
TB3 21 to 30 - Digital inputs,
TB4 31 to 32 - Digital inputs,
 33 - +24V,
 34 to 39 - Digital outputs,
 40 - 0V.

Block	Number	Description	Electric characteristics	Programmable	
TB1	1	+10V	Reference supply - $\pm 1\%$ - 10 mA maxi.		
	2	- 10V	Reference supply - $\pm 1\%$ - 10 mA maxi.		
	3	SPEED : Speed reference	Analog input - impédance : 100k Ω -10V to +10V or 500 Ω 0 to 20 mA	Yes	
	4 5 6 7	GP1 GP2 GP3 GP4 } Programmable inputs	Analog input - impédance : 100k Ω -10V to +10V	Yes	
	8	THERM : Motor thermistor input	Analog input - trip level : 3k Ω - reset : 1,8k Ω		
	9	TACHO - : Tachogenerator input	Analog input		
	10	TACHO + : Tachogenerator positive input	Analog input		
TB2	11	CURR : Armature current	Analog output - 6,66 V for the rated current 5 mA		
	12 13 14	DAC1 : DAC2 : DAC3 : } Programmable outputs	Analog output - output voltage -10V to +10V -5mA	Yes	
	15 16 17 18 19	ST1 ST2 ST3 ST4 ST5 } Programmable outputs	Digital output - open collector 0/24V - 50mA	Yes	
	20	0V	Common (40)		
	TB3	21	F1 : Run permit	Digital input - impédance 10k Ω	
		22	F2 : Inch reverse	Digital input - impédance 10k Ω	Yes
23		F3 : Inch forward	Digital input - impédance 10k Ω	Yes	
24		F4 : Run reverse (latched)	Digital input - impédance 10k Ω	Yes	
25		F5 : Run forward (latched)	Digital input - impédance 10k Ω	Yes	
26 27 28 29 30		F6 F7 F8 F9 F10 } Programmable inputs	Digital input - impédance 10k Ω	Yes	
TB4		31	ENABLE	Digital input - operates directly on the output gate-pulse circuits within a delay of 30 ms	
	32	RESET	Digital input		
	33	+24V	Relay supply - 200 mA max		
	34 35 36	POLE NC NO } ZERO SPEED (relay)	Digital output : common normally closed 5VDC - 5A - 250 VAC - 2.2A normalmy open 110 VAC - 5A	Yes	
	37 38 39	POLE NC NO } DRIVE READY (relay)	Digital output : 5VDC - 5A - 250 VAC - 2.2A - 110 VAC - 5A common normally closed normally open		
	40	0V	Common (20)		

Three-phase controllers DMV 2322 / DMV 2342

c) Auxiliary connectors

Pin location

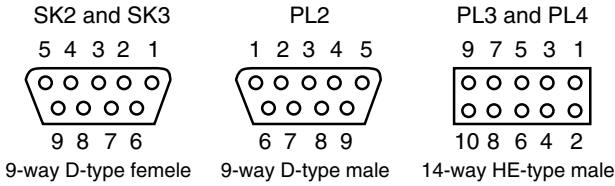

Câblage.

Pin	Signals			
	PL4	PL3	SK3	PL2
1	0V	0V	0V	0V isolated
2	NC	Supply	Supply	$\overline{\text{TX}}$
3	A	A	A	$\overline{\text{RX}}$
4	$\overline{\text{A}}$	$\overline{\text{A}}$	$\overline{\text{A}}$	NC
5	B	B	B	NC
6	$\overline{\text{B}}$	$\overline{\text{B}}$	$\overline{\text{B}}$	TX
7	NC	NC	NC	RX
8	C	C	C	NC
9	$\overline{\text{C}}$	$\overline{\text{C}}$	$\overline{\text{C}}$	NC
10		0V		

Nota : NC = non-connected.

PL5 (34-way, HE-type male)

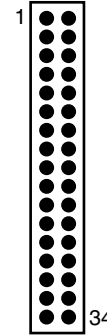

Pin		Pin	
1	+ 10V	18	ST4
2	- 10V	19	ST5
3	Speed feedback	20	0V
4	GP1	21	F1
5	GP2	22	F2
6	GP3	23	F3
7	GP4	24	F4
8	Thermistor	25	F5
9	NC	26	F6
10	0V	27	F7
11	Armature current	28	F8
12	DAC 1	29	F9
13	DAC 2	30	F10
14	DAC 3	31	ENABLE
15	ST1	32	RESET
16	ST2	33	+ 24V
17	ST3	34	0V

2.2 - Cables and protections definition

DMV rating	25	45	75	105	155	210	350	420	550	700	825	900	1200	1850
Fuses FU1 to FU3 *	gl 32	gl 50	gl 80	gl 125	gl 160	gl 250	gl 400	gl 500	gl 630	gl 800	gl 900	gl 1000	gl 1250	gl **
Fuse FU4 ***	uR 40	uR 63	uR 100	uR 160	uR 200	uR 315	uR 500	uR 630	uR 700	uR 900	uR 1000	uR 1250	uR 1600	uR **
Fuses 10x38 Field and Electronic supply ****	2xuR 6A	2xuR 6A	2xuR 6A	2xuR 6A	2xuR 6A	2xuR 6A	2xuR 20A	2xuR 20A	2xuR 20A	2xuR 20A	2xuR 20A	2xuR 20A	2xuR 20A	2xuR 20A
Fuses 10x38 peak limit ****	-	-	-	-	-	-	3xuR 6A 10x38	3xuR 6A 10x38	3xuR 6A 10x38	3xuR 6A 10x38	3xuR 6A 10x38	3xuR 30A 14x51	3xuR 30A 14x51	3xuR 30A 14x51
Field circuit-breaker (A)	Calculation : $\frac{\text{Field current} \times \text{Field voltage}}{\text{Supply voltage} \times 0,9} = \text{rating of circuit-break}$													
3-phase (A) inductance on the supply (mH)	25 1	38 0,65	60 0,4	90 0,28	130 0,19	176 0,14	292 0,085	460 0,055	460 0,055	750 0,032	750 0,032	750 0,032	1000 0,025	1540 0,016
Cable size AC input and DC output (mm ²)	4	6	25	35	50	95	150	185	300	2x185	2x240	2x240	2x400	3x400
Cable size field supply (mm ²)	2,5	2,5	2,5	2,5	2,5	2,5	2,5	2,5	2,5	2,5	2,5	4	4	4

* Fuse with adaptor.

** Consult LEROY-SOMER.

*** Only for DMV 2342.

**** These fuses are included in the controller.

This table allows to define the minimum cable size at the rated current, the length of this cable is less than 30m. This table can not replace standards.

Three-phase controllers DMV 2322 / DMV 2342

2.3 - Power connections and typical control wiring

Nota : You do install in parallel with the relays and contactors coils, an adapted RC circuit.

QS : Disconnecting link.

T.G. : Tachogenerator.

KM1 : Line contactor.

KM2 : Fan contactor.

QM : Fan circuit breaker.

QF : Field + electronic supply circuit breaker.

SB1 : Power ON button.

SB2 : Power OFF button.

SB3 : Forward/Reverse button.

AU : Emergency stop.

KA : Auxiliary contactor.

Fu 1.2.3 : gl fuse.

Fu 4 :

uR fuse, fast " semiconductor " type only for DMV 2342.

RP : Reference potentiometer 10 kΩ.

L : 3-phase inductance (option).

2.3.1 - DMV 2322 - DMV 2342 : - coast to rest, - only one direction.

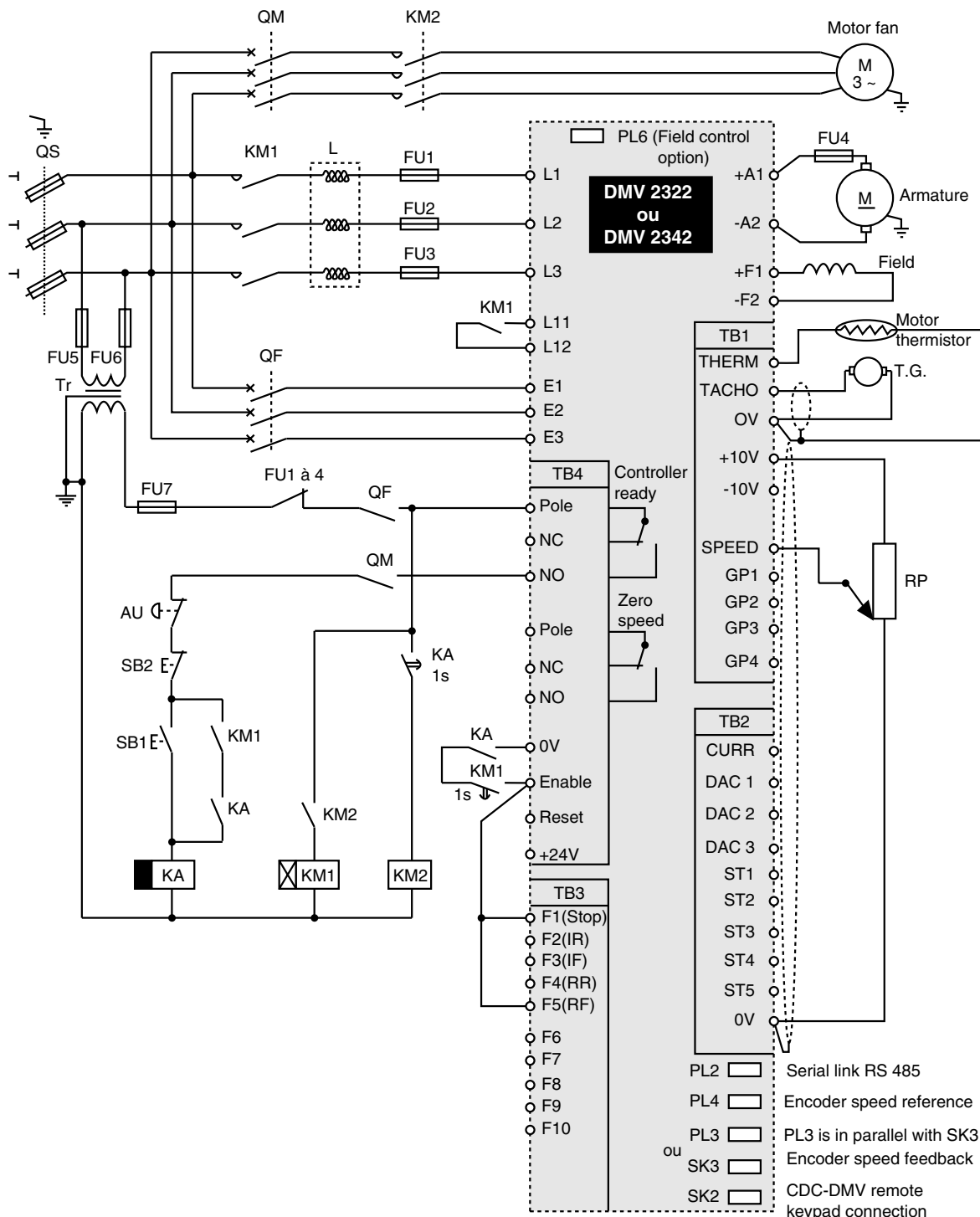

Three-phase controllers DMV 2322 / DMV 2342

2.3.2 - DMV 2322 - DMV 2342 : - ramp to stop,
- only one direction.

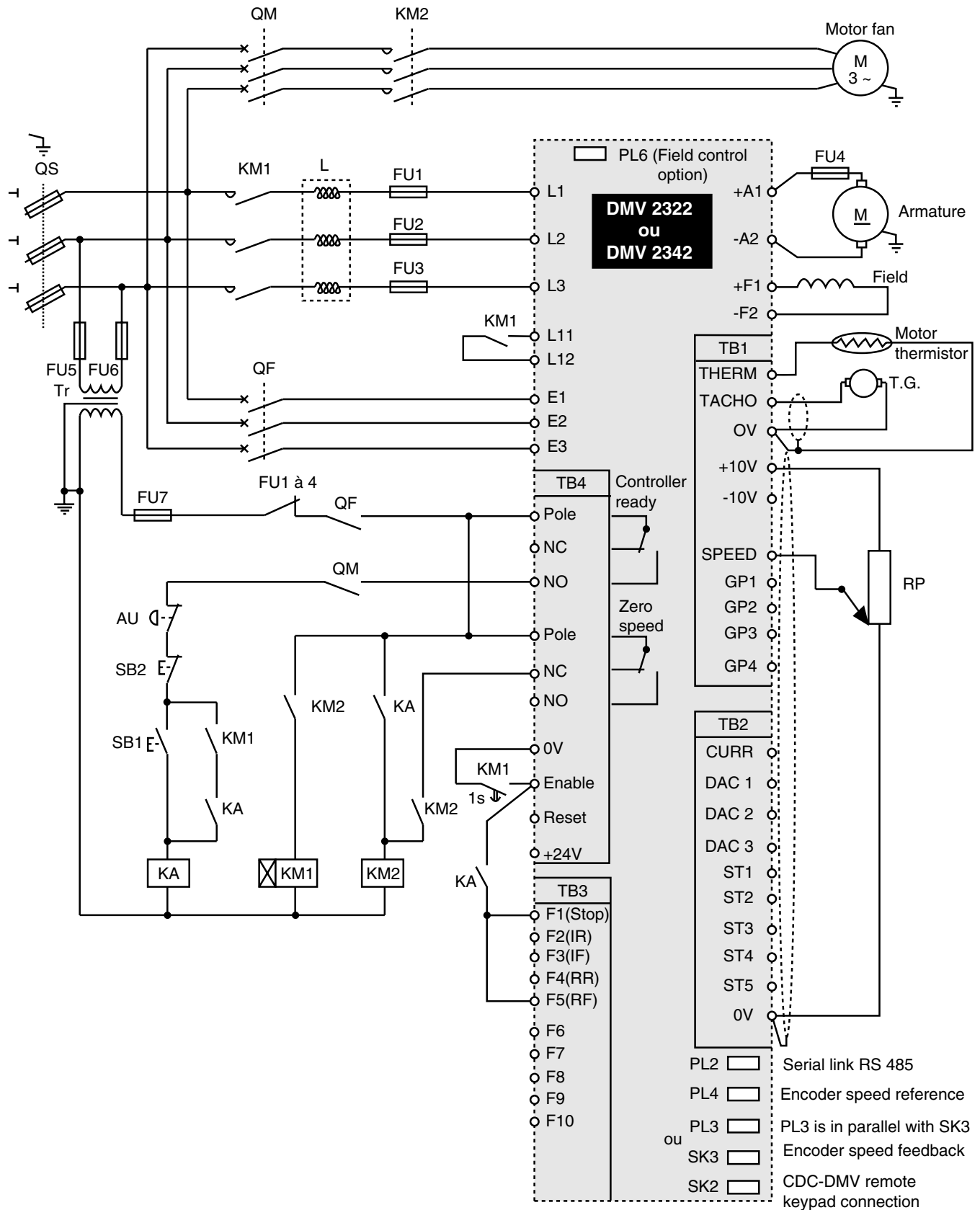

Three-phase controllers DMV 2322 / DMV 2342

2.3.3 - DMV 2342 : - emergency stop : coast to rest,
- ramp to stop,
- forward - reverse direction selected by the reference.

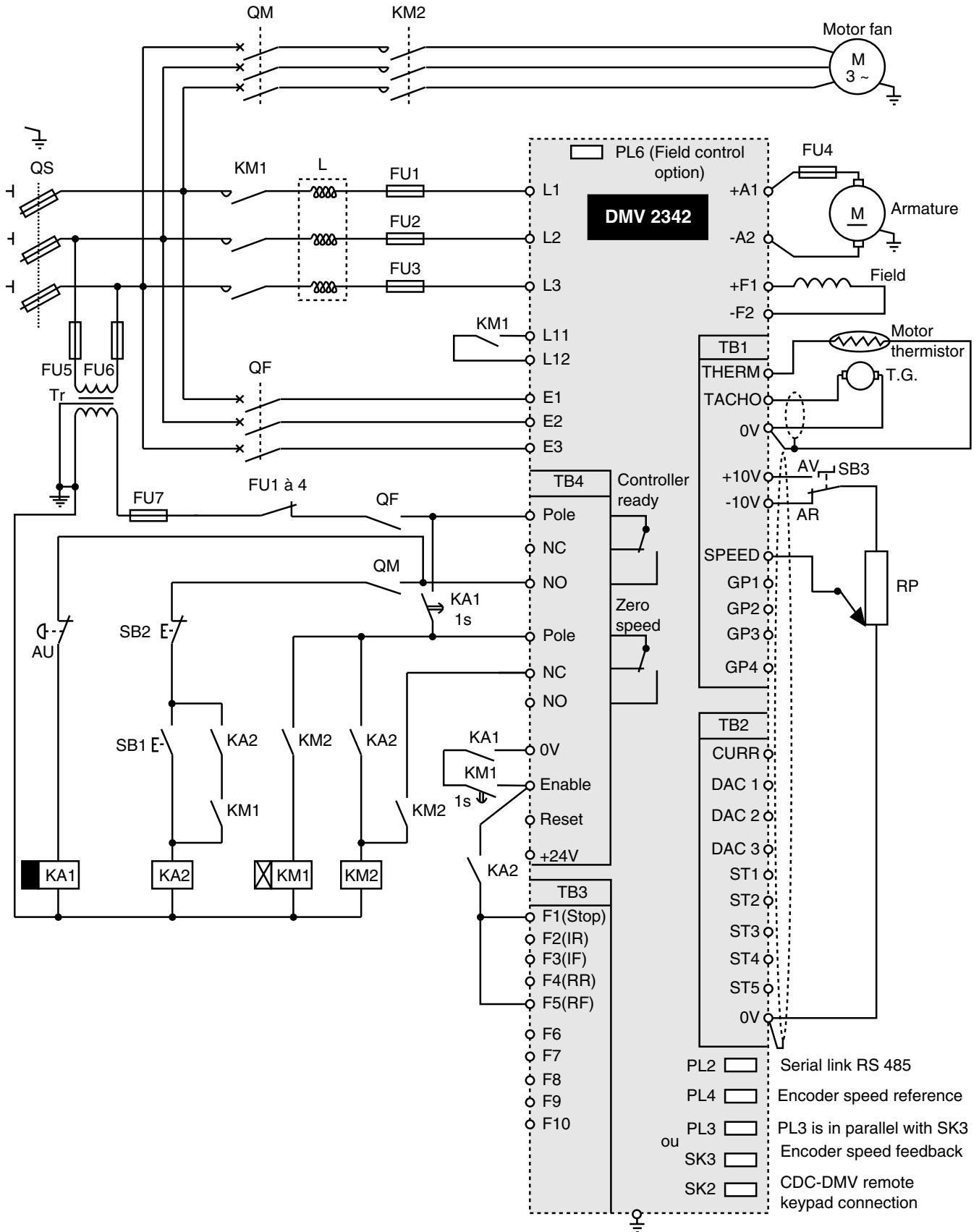

Three-phase controllers

DMV 2322 / DMV 2342

2.3.4 - DMV 2342 : - ramp to stop,
- forward - reverse direction selected by the reference.

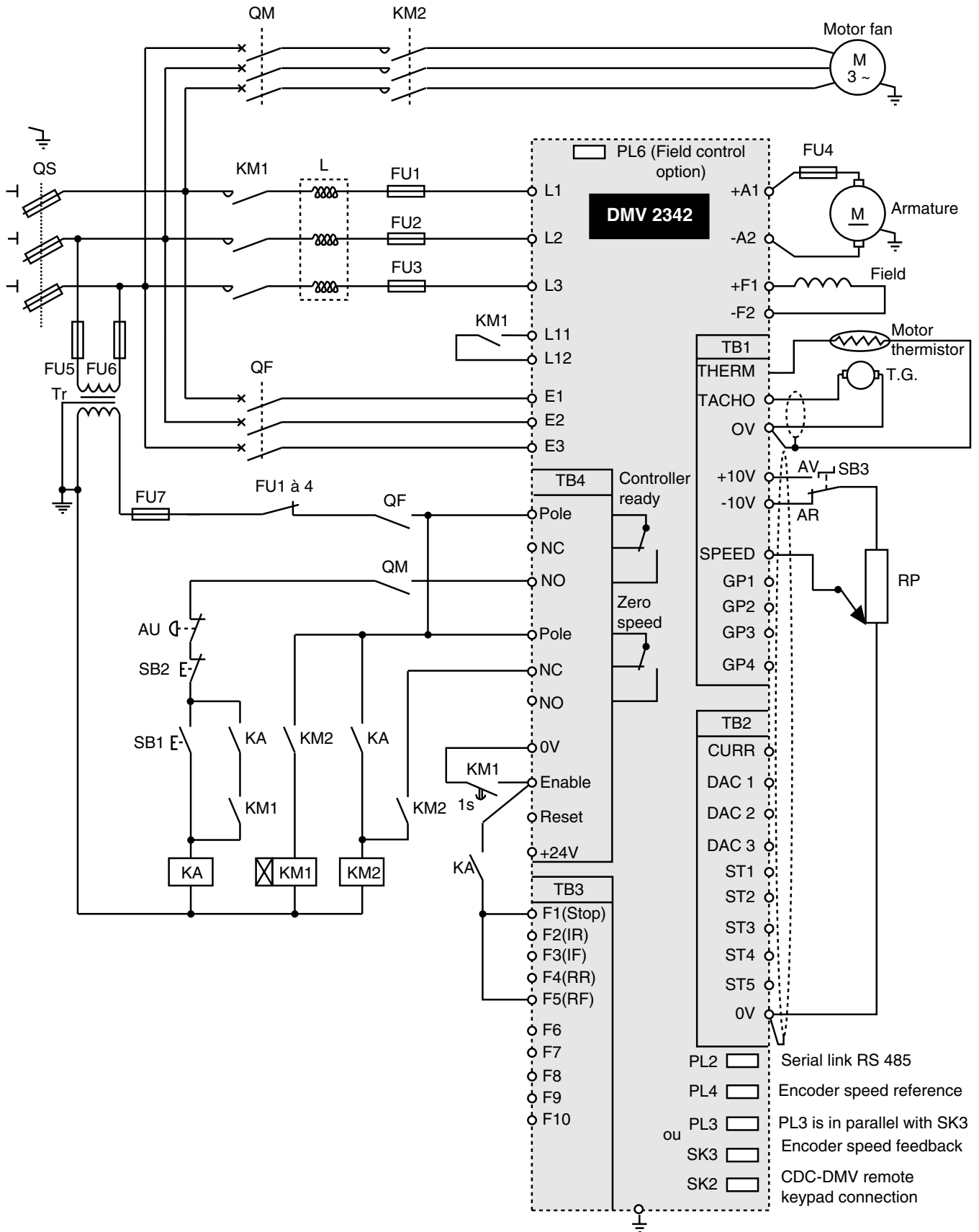

Three-phase controllers DMV 2322 / DMV 2342

- 2.3.5 - DMV 2342 : - ramp to stop,
 - forward - reverse direction selected by logic inputs,
 - positive speed reference,
 - emergency stop : coast to rest.

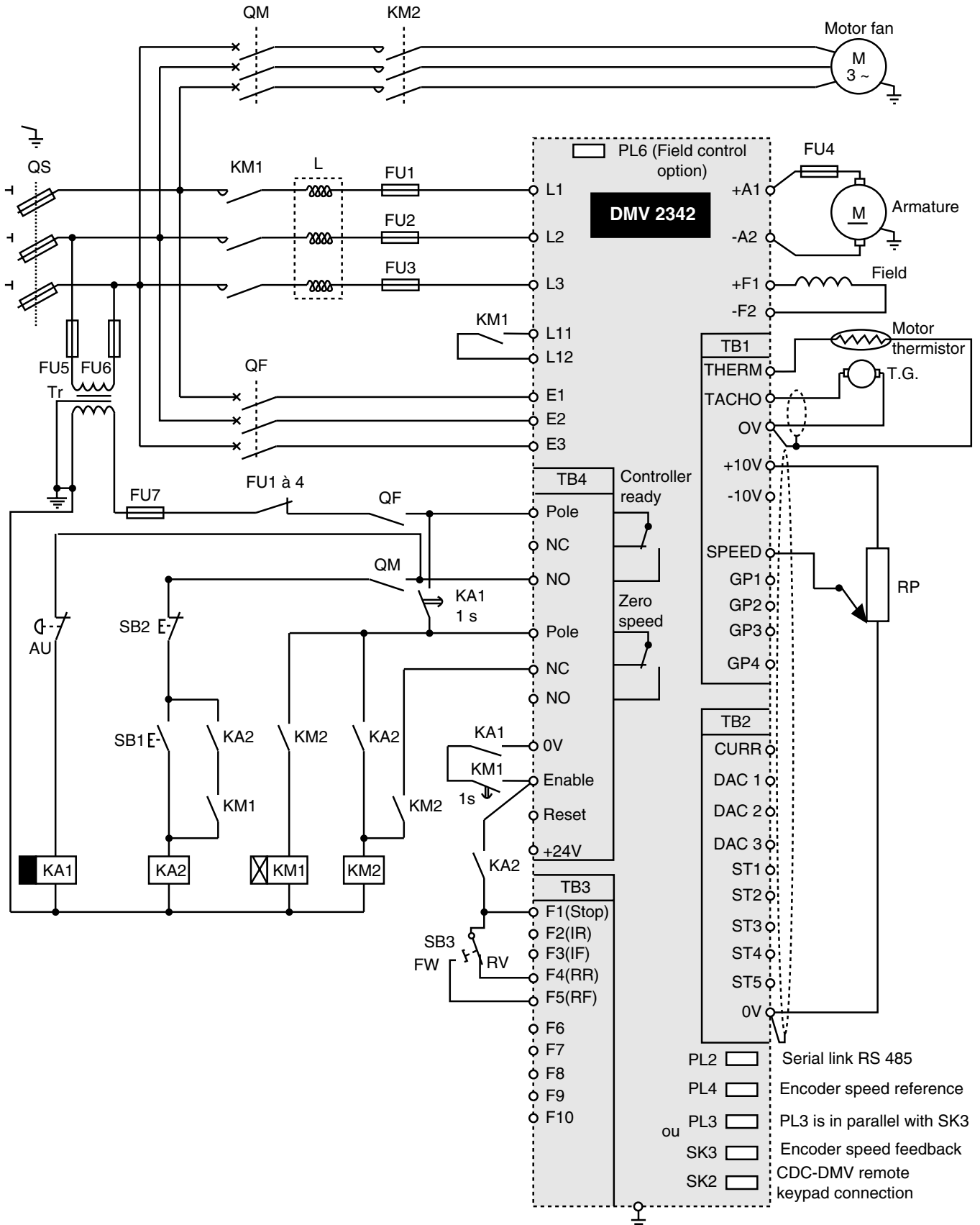

Three-phase controllers

DMV 2322 / DMV 2342

3 - COMMISSIONING

Note : this section is in six parts :

- Keypad procedure.

Familiarity with the keypad is vital in order to be able to select and modify the parameter values which are split into separate function related menus.

- Setting up the variable speed drive.

This is a simplified procedure, suitable for all applications involving the controller's basic variable speed drive function, and excluding the other computer-related functions of which it is capable.

This subsection deals with every aspect of speed reference :

voltage/current/encoder ; speed feedback : armature, DC tacho, encoder.

- List of menus and parameters.

A menu-by-menu explanation of all the parameters.

- List of logic diagrams.

Logic diagrams exist for most menus so that the relationships between parameters can be visualized.

3.1 - Keypad procedure

The user interfaces keypad and display on the **DMV 2322** and the **DMV 2342** are identical except for the model identification markings.

3.1.1 - Presentation

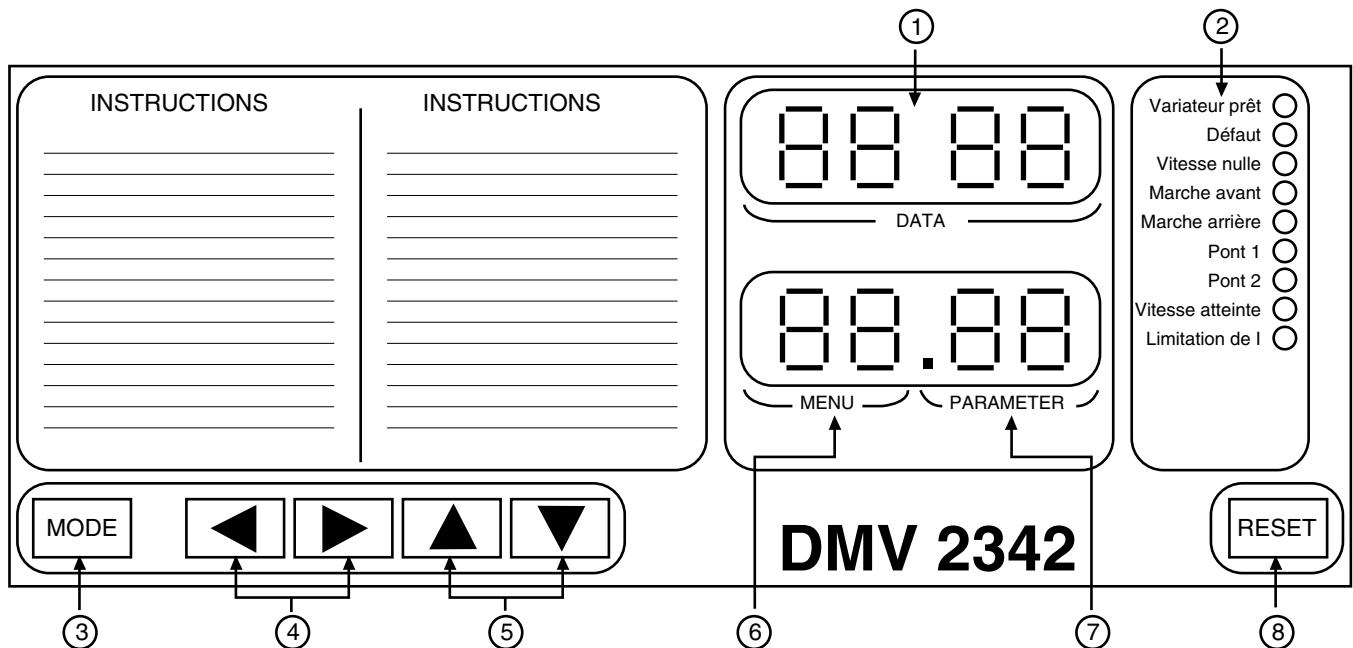

- ① 4-digit seven-segment display showing parameter data value.
- ② 9 LED status indicators.
- ③ MODE key changes from READ mode to SET mode.
- ④ Menu selection.
- ⑤ Parameter selection and data modification.
- ⑥ 2-digit seven-segment display showing menu number.
- ⑦ 2-digit seven-segment display showing parameter number.
- ⑧ RESET key for storing settings or resetting trips.

Three-phase controllers

DMV 2322 / DMV 2342

3.1.2 - Programming organization

The configuration of a variable speed drive for a given application is carried out by programming in the relevant parameters.

For simpler programming, the 390 parameters have been grouped into 16 menus. Each menu contains functionally-related parameters.

Menu	Description
01	Speed reference - selection and limitation.
02	Acceleration and deceleration ramps.
03	Speed regulation loop and speed feedback selection.
04	Selection and limitation of armature current.
05	Current regulation loop.
06	Field control (for use only with EXC-DMV field-weakening option).
07	Configuration of analogue inputs and outputs.
08	Configuration of logical inputs.
09	Configuration of logical outputs and relay RL2.
10	Status logic and diagnostic information.
11	Miscellaneous functions.
12	Programmable thresholds.
13	Position loop.
14	CAP - DMV system set-up.
15	Applications MENU 1.
16	Applications MENU 2.

Parameters can take the following ranges of values :
 000 to 255 (preceded by the symbol \square) ; 000 to + 1999 ;
 000 to \pm 1000 or 0 to 1 (preceded by the symbol \square).

They are accessible in two ways :

- "READ ONLY" : LS/RO, e.g. motor speed, motor current, etc.
- "READ/WRITE" : LE/RW, e.g. acceleration ramp n°1.

To prevent access to certain functions parameters, there are three levels of security.

Note : s. 3.3 contains the full list of menus and all 390 parameters.

This includes :

- functions associated to each menu,
- access mode for each parameter LE (RW) or LS (RO),
- access level (security),
- type of variable : logic or analogue,
- factory setting,
- range of setting,
- exact function of each parameter.

3.1.3 - Selecting a function and modifying its value

E.g. : forward acceleration time : function 02.04,

initial value = + 050,

new setting = + 200.

1) Use \square and C to select menu 02 on the MENU display (the two left-hand digits of the lower display window).

2) Use D and E to select parameter 04 on the PARAMETER display (the two right-hand digits of the lower display window).

3) The initial value is displayed in DATA + 050 (the four digits of the upper display window).

4) Press the \square key to enter the setting mode.

Setting is only possible when the DATA display is flashing.

5) Use the D key to alter the value to + 200.

6) Press the \square key again to quit SET mode.

7) Press RESET.

3.1.4 - Storing a new value

All the parameters that have been modified in all the menus will be stored at once, as follows :

Using the D and E keys, select parameter 00 in any menu.

Using the procedure described in 3.1.3, set the value in DATA to 01, as follows :

Read the initial value of parameter 00

Press \square , the number should flash.

Press D or E keys to modify the value to 01.

Press MODE.

Press RESET.

3.1.5 - Levels of protection for access to parameters

- Level 0.

When the controller is switched on for the first time, 262 parameters are accessible in READ, but only 35 can be modified without having to enter a special access code.

These are the 35 normal operating parameters.

They are marked "0" in s. 3.3.

- Level 1.

This level gives READ/WRITE access to all the modifiable parameters out of the 262 that are available when the controller is switched on.

To access level 1, enter code 149 in parameter 00 of any menu.

These parameters are marked "1" in s. 3.3.

- Level 2.

This gives unrestricted access to all 390 parameters in "READ/WRITE". For access, enter code 200 in parameter 00 of any menu.

3.1.6 - Protection by security code

WRITE access to all parameters can be prohibited using a security code.

Installing the security code :

1) - Use D and E to select parameter 00 of any menu.

- The initial value is displayed in DATA.

- Press \square , the number should flash.

- Use D to set 200 in DATA.

- Press \square .

2) - Use \square and C to select MENU 11.

- Use D and E to select parameter 17.

- Read the value in DATA : 149

- Press \square , the number should flash.

- Use D and E to install the desired security code between 01 and 255, except 149 (code for level 1).

- Press \square .

- Press RESET.

Once a security code has been installed, this code will have to be entered in parameter 00 of any menu in order to have WRITE access to any parameters

Note : level 1 and level 2 codes are still active and must also be entered following access requirements.

Three-phase controllers

DMV 2322 / DMV 2342

3.1.7 - Reprogram factory settings

- DMV 2342 : enter 233 in parameter 00 00, then press RESET.
- DMV 2322 : enter 255 in parameter 00 00, then press RESET.

3.2 - Commissioning of DC variable speed drive

This procedure is valid for both **DMV 2322** and **DMV 2342**.

Reference is made to the terminal connections (see s. 2.3).

The MDA2 interface card has to be configured for the setting of potentiometer RV1 and the position of the switches SW1.

You will need to program the controller using the keypad procedure described in s. 3.1.

The following operations must be **carried out in the order they appear in the procedure**.

3.2.1 - Checking the connections (Power off)

- Visual check.
- Open circuit-breaker QF.
- Using a multimeter, measure the resistance between the points indicated in the table below.

Ohmmeter position		Reading
L1	L2	> 1 MΩ
L1	L3	> 1 MΩ
L2	L3	> 1 MΩ
E1	Metal frame	> 1 MΩ
E2	Metal frame	> 1 MΩ
E3	Metal frame	> 1 MΩ
L1	A1 - A2	∞
L2	A1 - A2	∞
L3	A1 - A2	∞
TB1 - 3	Metal frame	> 1 MΩ *
TB1 - 8	Metal frame	> 1 MΩ *
TB1 - 9	Metal frame	> 1 MΩ *
TB1 - 10	Metal frame	> 1 MΩ *
TB1 - 21	Metal frame	> 1 MΩ *
TB1 - 24	Metal frame	> 1 MΩ *
TB1 - 25	Metal frame	> 1 MΩ *
TB1 - 26	Metal frame	> 1 MΩ *
TB1 - 31	Metal frame	> 1 MΩ *
TB1 - 32	Metal frame	> 1 MΩ *
TB1 - 40	Metal frame	> 1 MΩ *
A1	F1 - F2	> 1 MΩ
A2	F1 - F2	> 1 MΩ
TB1 - 8	A1 - A2	> 1 MΩ
TB1 - 8	A1 - A2	> 1 MΩ
TB1 - 10	A1 - A2	> 1 MΩ
TB1 - 10	F1 - F2	> 1 MΩ
TB1 - 10	L1 - L2 - L3	> 1 MΩ

* Provided that the 0V (TB1 - 10, TB1 - 20, TB1 - 40) is not earthed. Otherwise, the reading will be 0Ω.

3.2.2 - Switching the controller on

Disconnect TB4 - 31 (ENABLE).

Power up E1 - E3, by closing QF. The electronics are now on, and the LED's on the front panel should flash in a circular pattern for 2 seconds.

Do not open QF if the procedure does not say so.

If opened, recommence the whole procedure from the start of this section (3.2).

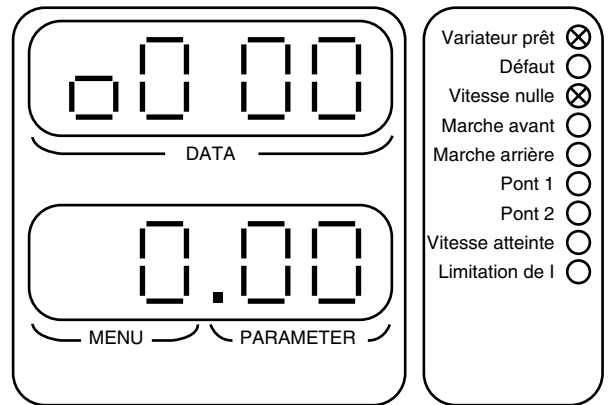

Note : during the set-up procedure, the controller may indicate a fault as shown below.

Example :

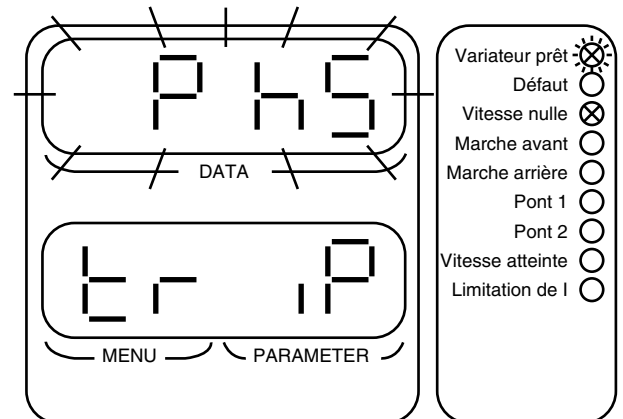

The trip code, in this case "**Ph S**", flashes.

To identify and correct the fault, consult section 5 "Troubleshooting and maintenance".

Attention :

A flashing "Drive ready" LED indicates that there is a fault.

If the "Alarm" LED lights up, it warns that there is an overload condition.

Three-phase controllers DMV 2322 / DMV 2342

3.2.3 - Selecting the logic input polarity

The selection of the position of switch 1 of SW1 will depend on the following remote controls :

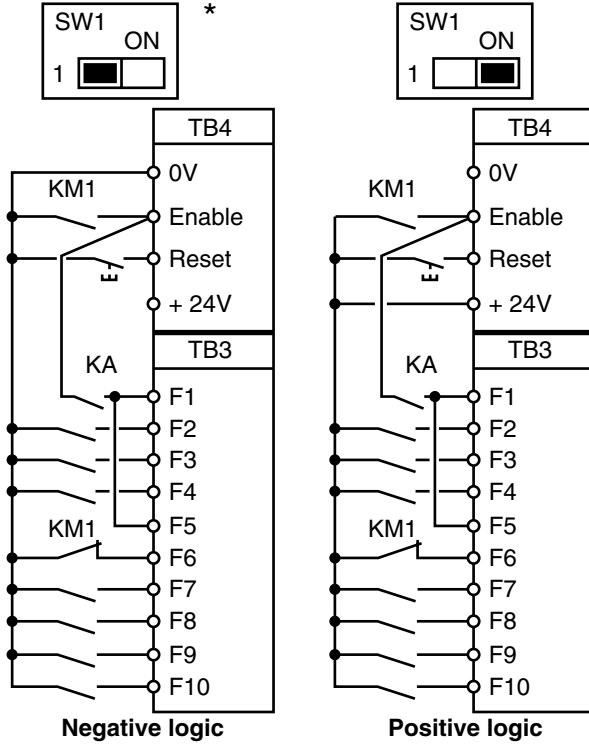

* This position is to be used with the recommended connection diagrams given in this manual.

3.2.4 - Motor temperature monitoring

- Connect PTC motor sensor to terminal block TB1.

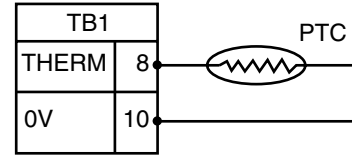

- Detection operation.

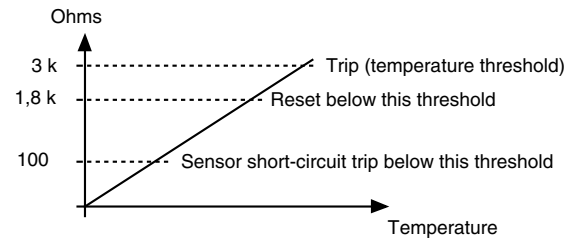

- Programming required for temperature monitoring selection.

Menu/ Parameter	Value to be entered	Remarks/ Calculations
0.00	200	Level 2 access code
10.32	0	with sensor
	1	without sensor
Press "RESET"		

3.2.5 - Speed reference control selection

a) Using digital keypad.

Do not connect the potentiometer to TB1.3/SPEED. Procedure for using the keypad to change speed :

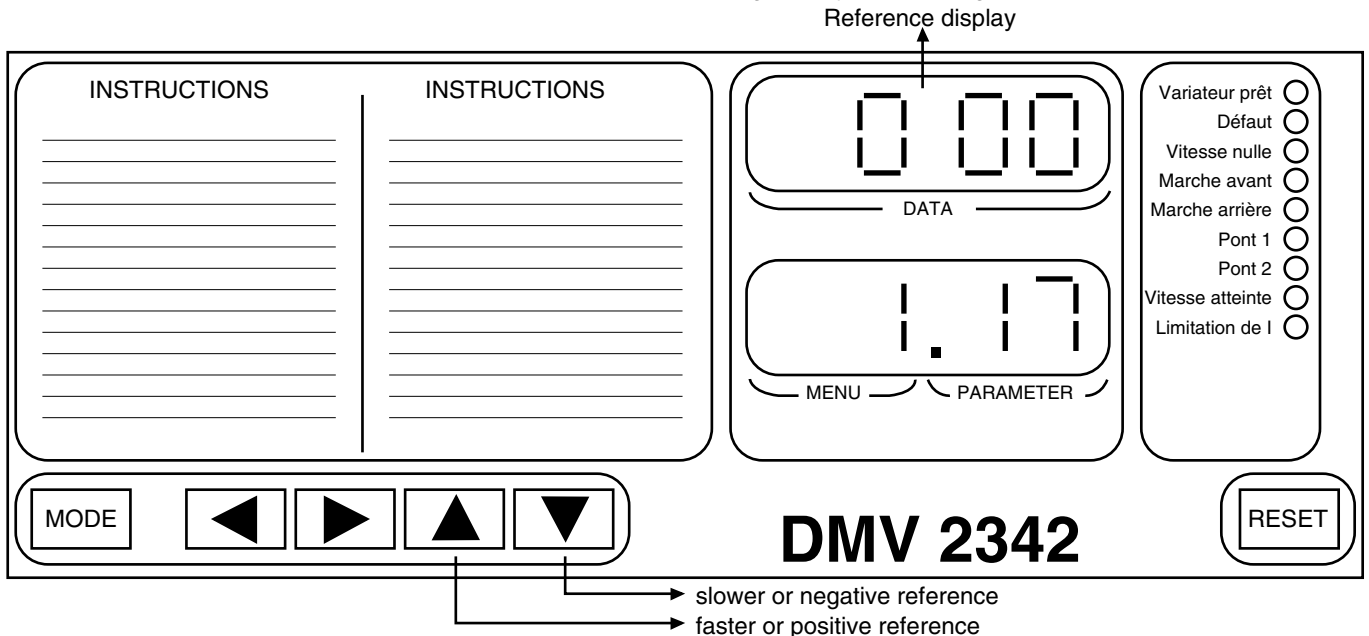

1.17 : parameter to be selected in order to control the reference via the keypad.

Programming required :

Menu/ Parameter	Value to be entered	Remarks/ Calculations
0.00	200	Level 2 access code
7.15	000	No allocation
Press "RESET"		

Three-phase controllers

DMV 2322 / DMV 2342

b) Using potentiometer or external voltage signal.
The speed reference is applied to terminal TB1 - 3 /- SPEED.
Programming required :

Menu/ Parameter	Value to be entered	Remarks/ Calculations
0.00	200	Level 2 access code
7.15	117	Allocation Ref. 1/TB1 - 3
7.20	1000	Scaling
7.25	0	Selection TB1 - 3
7.26	0	Selection voltage ref.
Press "RESET"		

c) Via external current signal
The signal is applied terminal TB1 - 3/SPEED.
Programming required :

Menu/ Parameter	Value to be entered	Remarks/ Calculations
0.00	200	Level 2 access code
7.27	0	0-20 mA signal
7.28	0	
7.27	1	20-0 mA signal
7.28	0	
7.27	0	4-20 mA signal
7.28	1	
7.27	1	20-4 mA signal
7.28	1	
7.15	117	Allocation Ref. 1/TB1 - 3
7.20	1000	Scaling
7.25	0	Selection TB1 - 3
7.26	1	Selection current ref.
Press "RESET"		

d) Using an encoder signal
The reference encoder is connected to socket PL4 (PL4 does not power the encoder).
The encoder may be powered from an external source.
The TB1 - 3/SPEED input is not used.
Programming required :

Menu/ Parameter	Value to be entered	Remarks/ Calculations
0.00	200	Level 2 access code
7.15	117	Allocation Ref. 1/PL4
7.20	1000	Scaling
7.25	1	Selection PL4
7.24	0 to 1999	Scaling of the encoder's maximum output frequency. Value to be entered : $\frac{750 \times 10^6}{N \times n}$ N : number of pulses per encoder revolution. n : max speed of motor in rpm.
Press "RESET"		

3.2.6 - Speed feedback selection

a) Without DC tachogenerator
The armature voltage is regulated, no connections are necessary.

Programming required :

Menu/ Parameter	Value to be entered	Remarks/ Calculations
0.00	200	Level 2 access code
3.12	0	Selection } armature voltage feedback
3.13	1	
Press "RESET"		

b) With DC tachogenerator
The tachogenerator is connected to terminals TB1 - 9 and TB1 - 10.
Position link LK1 on the MDA2 board to F/B.
Programming required :

Menu/ Parameter	Value to be entered	Remarks/ Calculations
0.00	200	Level 2 access code
3.12	0	Selection } armature voltage feedback
3.13	0	
Press "RESET"		

c) With encoder (absolute speed regulation)
Connect the encoder to socket SK3.
Set switches 2, 3 and 4 of SW1 on the MDA2 board to the corresponding encoder supply voltage (if the encoder is not powered by the controller, skip this operation).

+ 5V		+ 12V		+ 15V	
SW1	ON	SW1	ON	SW1	ON
2	<input checked="" type="checkbox"/>	2	<input type="checkbox"/>	2	<input type="checkbox"/>
3	<input type="checkbox"/>	3	<input checked="" type="checkbox"/>	3	<input type="checkbox"/>
4	<input type="checkbox"/>	4	<input type="checkbox"/>	4	<input checked="" type="checkbox"/>

Adjust resistances R10 - R11 - R12.

Programming required :

Menu/ Parameter	Value to be entered	Remarks/ Calculations
0.00	200	Level 2 access code
3.12	1	Selection encoder feedback
Press "RESET"		

Three-phase controllers

DMV 2322 / DMV 2342

3.2.7 - Setting the armature current and field current

a) Setting the armature current

Check the output current on the controller name plate.

Check the armature current on the motor name plate.

Programming required :

Menu/Parameter	Value to be entered	Remarks/Calculations
0.00	200	Level 2 access code
4.05	1000	Limit bridge 1
4.06	1000	Limit bridge 2
4.04	0 to 1000	Maximum armature current setting. Calculation : $\frac{666 \times \text{rated motor } I}{\text{rated controller } I} \times \frac{M_D}{M_N} =$ value to be entered. M_D : required overload M_N : capacity
5.05	0 to 1999	Scaling of current reading. Calculation : rated controller I x 1.5 = value to be entered. For $I_n = 1850$ A, the coefficient to be applied is 0.15.
Press " RESET "		

b) Setting the field current, 3 possibilities

- For DMV 2322/DMV 2342 from 25 to 210A with field regulation without field weakening.

- Check the field current and voltage on the motor name plate and check on § 2.1.1 b that the field circuit is compatible.

Menu/Parameter	Value to be entered	Remarks/Calculations
0.00	200	Level 2 access code
6.07	1000	Without field weakening
6.08	0 to 1000	Setting of field current $\frac{1000 \times \text{field current}}{8}$ value to be entered.
6.11	216	Internal rating selection
6.13	1	EXC - DMV 8 enable
Press " RESET "		

Put the J1 link of the EXC - DMV 8 (MDA3) board on 8A position.

• For DMV 2322/DMV 2342 from 350 to 1850A :

- no regulated field,

- no particular setting,

- check that the field voltage indicated on the motor name plate is compatible with the supply voltage (see § 2.1.1 b).

• For DMV 2322/DMV 2342 from 25 to 210A with regulated field and field weakening.

The field weakening gives the possibility to increase the speed above the nominal speed while keeping a constant armature voltage.

Nota : The motor must be equipped with a tacho or encoder feedback. It is totally forbidden to use armature voltage feedback, as an overspeed will automatically occur.

- Check the field current and voltage on the motor name plate and check that it is compatible with the supply voltage (§ 2.1.1 b).

- Put the J1 link of the EXC - DMV 8 (MDA3) board in :

- 2A position of the field current ≤ 2 A,

- 8A position of the field current ≤ 8 A.

Menu/Parameter	Value to be entered	Remarks/Calculations
0.00	200	Level 2 access code
3.13	0	Armature voltage feedback forbidden.
3.15	600	Maximum armature voltage threshold.
6.11	201 to 216	Choice of the rating depending on the current indicated on the motor name plate : 0,5 A value to be entered : 201 1 A value to be entered : 202 1.5 A value to be entered : 203 2 A value to be entered : 204 2.5 A value to be entered : 205 3 A value to be entered : 206 3.5 A value to be entered : 207 4 A value to be entered : 208 4.5 A value to be entered : 209 5 A value to be entered : 210 5.5 A value to be entered : 211 6 A value to be entered : 212 6.5 A value to be entered : 213 7 A value to be entered : 214 7.5 A value to be entered : 215 8 A value to be entered : 216 Example : - field : 2.8A, - rating chosen : 3A, - value to be entered : 206.
6.07	0 to 1000	Field weakening threshold. Value to be entered = armature voltage. Nota : This voltage should never be set greater than 1.16 x supply voltage.
6.08	0 to 1000	Accurate setting of the field current. Calculation : $\frac{1000 \times \text{field current in Am}}{\text{current (Amps) chosen in parameter 6.11}}$ = value to be entered.
6.10	0 to 1000	Minimum flux. Calculation : $\frac{\text{Value of 6.08}}{4}$ value to be entered.
6.13	1	Field control enable
6.14	0	
6.15	0	
6.16	0	
6.17	0	
6.18	0	
6.19	0	
6.20	0	

Three-phase controllers

DMV 2322 / DMV 2342

Menu/ Parameter	Value to be entered	Remarks/ Calculations
6.21	0 to 1000	Field voltage limitation $1500 \times \text{field}$ supply volta value to be entered. (Enter 1000 if the result is over 1000).
000	1	Store settings
Press " RESET "		

3.2.8 - Setting maximum speed

a) Without DC tachogenerator or encoder

The speed depends on the armature voltage that has been set by parameter 3.15.

Programming required :

Menu/ Parameter	Value to be entered	Remarks/ Calculations
0.00	200	Level 2 access code
3.15	0 to 1999	Motor armature voltage "V" motor armature ⁽¹⁾ x operating speed ⁽²⁾ / motor speed ⁽³⁾ = value to be entered ⁽⁴⁾ (1) : plated armature voltage (Volts) (2) : defined operating speed (rpm) or motor speed (3) : plated motor speed (rpm) (4) : this value must not exceed : - 260 for 220V mains - 440 for 380V mains - 460 for 415V mains - 510 for 460V mains - 530 for 480V mains
3.16	0 to 1999	Scaling of speed read-out (3.03). Value to be entered : operating speed ⁽²⁾ in rpm Example : 1500 for 1500 rpm 300 for 3000 rpm
Press " RESET "		
0.00	1	Store all modified parameters
Press " RESET "		

b) With DC tachogenerator

- Calculate the voltage given by the DC tacho at operating speed (or maximum speed).

Motor speed x V/rpm tacho = tacho voltage

Motor speed : rpm

V/rpm tacho : 0.06 V/rpm (see tacho name plate)

- Position switches 6, 7 and 8 of SW1 on the MDA2 board to select the range corresponding to the tacho voltage.

10 to 50V	50 to 200V	60 to 300V
SW1 ON 6 <input type="checkbox"/> <input checked="" type="checkbox"/> 7 <input checked="" type="checkbox"/> <input type="checkbox"/> 8 <input checked="" type="checkbox"/> <input type="checkbox"/>	SW1 ON 6 <input checked="" type="checkbox"/> <input type="checkbox"/> 7 <input type="checkbox"/> <input checked="" type="checkbox"/> 8 <input checked="" type="checkbox"/> <input type="checkbox"/>	SW1 ON 6 <input checked="" type="checkbox"/> <input type="checkbox"/> 7 <input type="checkbox"/> <input checked="" type="checkbox"/> 8 <input type="checkbox"/> <input checked="" type="checkbox"/>

Programming and procedure required :

Menu/ Parameter	Value to be entered	Remarks/ Calculations
0.00	200	Level 2 access code
Place link LK1 of the MDA2 board to "Adj" position		
3.02	0 to 1000	Setting maximum speed. Calculation : $\frac{10000}{\text{Tacho voltage}} =$ value to be set at 3.02 by adjusting RV1 potentiometer on MDA2 board.
3.15	0 to 1000	Armature voltage. Calculation : motor armature voltage ⁽¹⁾ x 1.1 = value to be entered (1) : plated armature voltage
3.16	0 to 1999	Scaling of speed read-out (3.03). Value to be entered : operating speed in rpm. Example : 1500 for 1500 rpm 300 for 3000 rpm
Place link LK1 of the MDA2 board to "F/B" position		
Press " RESET "		
0.00	1	Store settings
Press " RESET "		

c) With encoder

Programming required :

Menu/ Parameter	Value to be entered	Remarks/ Calculations
0.00	200	Level 2 access code
314	0 to 1999	Maximum motor speed setting. Calculation : $\frac{750 \times 10^6}{N \times n} =$ value to be entered. N = number of pulses per encoder revolution. n : motor speed in rpm.
Press " RESET "		
0.00	1	Store settings
Press " RESET "		

Three-phase controllers DMV 2322 / DMV 2342

3.2.9 - Automatic adjustment of armature current stability

- open " QF ",
 - reconnect TB4 - 31/ENABLE,
 - disconnect L11 (or motor field),
 - close QF,
- Programming required :

Menu/Parameter	Value to be entered	Remarks/Calculations
0.00	200	Level 2 access code
5.09	1	" Autotune " selected

- give the motor a RUN command (motor remains at standstill).

There are two possible situations

- 1) The controller displays the following fault :

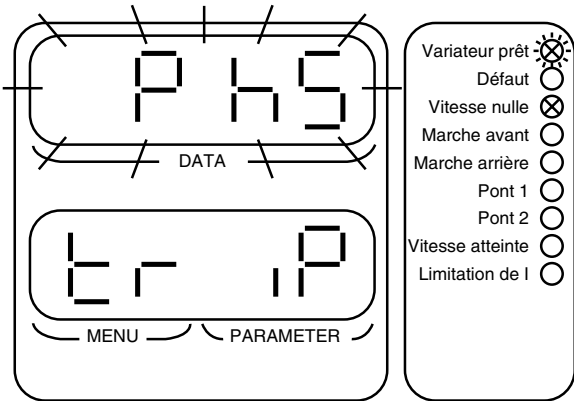

- there is a connection error. E1 - L1, E3 - L3 are out of phase,
- open QF,
- see connection diagram in s. 2.4 and correct E1 - E3 phase connections,
- recommence procedure of s. 3.2.9.

- 2) No fault is indicated :

- the controller is setting the current loop automatically (setting takes 1 sec max.),
- stop command is automatic.

Programming required :

Menu/Parameter	Value to be entered	Remarks/Calculations
Press " RESET "		
0.00	1	Store settings
Press " RESET "		

- open QF,
- reconnect L11 (or motor field),
- close QF.

3.2.10 - Running the motor

- Select 3-03, speed read-out in rpm.
- Give the motor a RUN command and increase speed reference gradually (up to maximum).
- The "DATA" display window indicates the speed of the motor in rpm.
- To alter the maximum speed : increase or decrease the armature voltage ; readjust the RV1 potentiometer speed setting or change the encoder programming (refer to s. 3.2.8).

3.2.11 - Adjusting speed stability

The gain of the speed loop is preset, but may be adjusted if speeds are unstable.

- a) Effect of proportional gain (following speed step change)

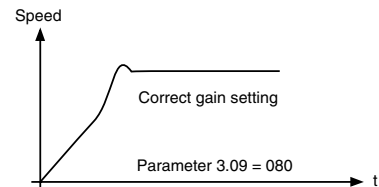
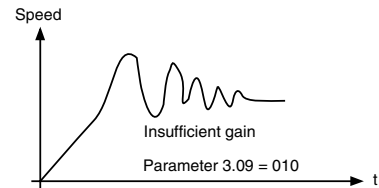
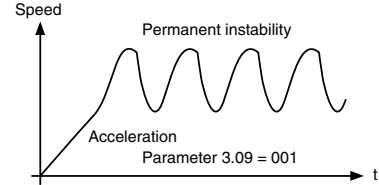

Note : if gain P is too high, the speed may become unstable and the " Bridge 1 " and " Bridge 2 " LED indicators will flash. If this is the case, reduce the value of parameter 3.09 until the LED Indicators stop flashing.

- b) Effect of integral gain (speed accuracy following load step change)

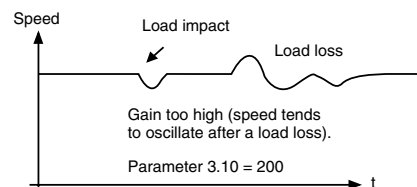
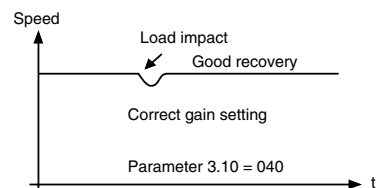
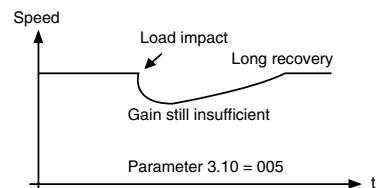
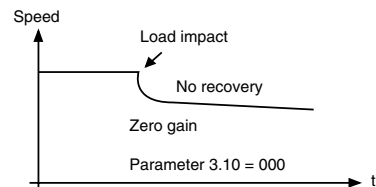

Three-phase controllers

DMV 2322 / DMV 2342

Note : it will be necessary to adjust the integral gain in order to stabilize the speed when there are continuous mechanical torque variations.

Programming required :

Speed variation is best observed with an oscilloscope measuring the tacho voltage (time base = 1 second).

Menu/Parameter	Value to be entered	Remarks/Calculations
0.00	200	Level 2 access code
		- give the motor a RUN command, - apply speed changes.
3.09	0 to 255	Adjust proportional gain (in accordance with observations and explanations in part a)
3.10	0 to 255	Adjust integral gain (in accordance with observations and explanations in part b)
		Give the motor a STOP command. Press " RESET "
0.00	1	Store settings Press " RESET "

3.2.12 - Selection and adjustment of ramps 1

The ramps 1 are preset at 5 seconds, but they may be adjusted using the following programming :

Menu/Parameter	Value to be entered	Remarks/Calculations
0.00	200	Level 2 access code
2.02	1	With ramp
2.14	0	Selection ramp 1
2.15	0	Selection ramp 1
2.16	0	Selection ramp 1
2.17	0	Selection ramp 1
2.18	0	Selection ramp 1
2.04	0 to 1999	FWD acceleration : 0 to 199.9 sec
2.05	0 to 1999	FWD deceleration : 0 to 199.9 sec
2.06	0 to 1999	REV deceleration : 0 to 199.9 sec
2.07	0 to 1999	REV acceleration : 0 to 199.9 sec
		Press " RESET "
0.00	1	Store settings Press " RESET "

3.2.13 - Measurements

The main characteristics of the variable speed drive can be checked against the required specification without the need for a multimeter by using the keypad and display of the DMV 2322 or DMV 2342. This is the last stage of the simplified commissioning procedure.

Measurement	Voltage L1 - L2 - L3 in Volts	Armature voltage in Volts	Armature current in Amps	Field current (with option) 0 to 100 % 0 to 1000
Reading				
Select parameter				
Measurement	Speed in rpm	Speed reference 0 to 100 % 0 to 1000	Reference before ramp 0 to 100 % 0 to 1000	Reference after ramp 0 to 100 % 0 to 1000
Reading				
Select parameter				
Measurement	Hard speed reference 0 to 100 % 0 to 1000	Torque reference 0 to 100 % 0 to 1000		
Reading				
Select parameter				

The commissioning procedure for the variable speed drive is now complete.

If your application involves more complex functions, refer to the end of this section, s. 3.3 to 3.4.

Three-phase controllers

DMV 2322 / DMV 2342

3.3 - List of menus and parameters

3.3.1 - Menu 01 : Speed reference

There are four speed references, 01.17, 01.18, 01.19 and 01.20. Each of the four can be given any single value in the range 1000 forward to 1000 in reverse (the value 1000 representing full speed), and can be rewritten through the keypad, the programmable inputs or the serial link at any time. The default destination for external speed reference (terminal TB1-3) is reference 1 (01.17), meaning that the external reference is present in reference 1 unless a different selection is made, from the other three references. The availability of four selectable speed reference parameters gives great flexibility in the use of references from other equipment. Such additional external references would be handled by general purpose analogue inputs, Menu 07, or digital logic inputs, Menu 08.

Two selectors, 01.14 and 01.15, control the application of the four internal references as the source speed reference.

Modifying factors applied to the source speed reference are, in sequence, an added offset, selection of bipolar or unipolar input, inversion of polarity (reverse), and the maxima and minima of forward and reverse speed, Menu 02.

Control selectors :

01.11 - Reference ON (if 01.11 = 0, pre-ramp reference = 0),

01.12 - Reverse (by reference inversion),

01.13 - Inch speed reference (01.05).

The speed reference at source, 01.01 is the input to the zero reference interlock 01.16, which (when selected, 01.16 = 1) inhibits the drive starting until the speed reference is close to zero.

3.3.1.1 - List of parameters Menu 01

RO = Read Only.

R/W = Read/Write.

A = Analog.

L = Logic.

Level 0 et 1

Parameter	Description	Acces level	Type RO / R/W	Variable A/L	Range	Default
01.01	Pre-offset speed reference	-	RO	A	± 1000	
01.02	Post-offset speed reference	-	RO	A	± 1000	
01.03	Pre-ramp reference	-	RO	A	± 1000	
01.04	Offset	1	R/W	A	± 1000	+000
01.05	Inch reference	0	R/W	A	± 1000	+050
01.06	Maximum speed forward	0	R/W	A	0 to + 1000	+1000
01.07	Minimum speed forward	1	R/W	A	0 to + 1000	+000
01.08	Minimum speed reverse	1	R/W	A	-1000 to 0	+000
01.09	Maximum speed reverse	0	R/W	A	-1000 to 0	(2342) - 1000 (2322) - 000
01.10	Bipolar reference selector	1	R/W	L	0 or 1	(2342) 1 (2322) 0
01.11	Reference " ON "	0	R/W	L	0 or 1	0
01.12	REVERSE selector	0	R/W	L	0 or 1	0
01.13	INCH selector	0	R/W	L	0 or 1	0

Level 2

Parameter	Description	Acces level	Type RO / R/W	Variable A/L	Range	Default
01.14	Reference select 1	2	R/W	L	0 or 1	0
01.15	Reference select 2	2	R/W	L	0 or 1	0
01.16	Zero reference interlock	2	R/W	L	0 or 1	0
01.17	Reference 1	2	R/W	A	± 1000	(07.15)
01.18	Reference 2	2	R/W	A	± 1000	+300
01.19	Reference 3	2	R/W	A	± 1000	(07.12)
01.20	Reference 4	2	R/W	A	± 1000	(07.13)

Three-phase controllers

DMV 2322 / DMV 2342

3.3.1.2 - Menu 01 parameters description

- RO (Read Only)
- R/W (Read/Write)

01.01 : Pre-offset speed reference

Range : ± 1000 .

Monitors the value of the speed reference continuously. Parameter 01.01 is also used to initiate the zero speed reference interlock, 01.16.

01.02 : Post-offset speed reference

Range : ± 1000 .

Monitors the value of the speed reference after the offset, 01.04, has been added.

01.03 : Pre-ramp reference

Range : ± 1000 .

The final speed reference before any ramp rates are applied (refer to Menu 02).

01.04 : Offset

Range : ± 1000 .

Default : +000.

The analogue reference offset (range -1000 to +1000) is a programmable speed demand term added to the speed reference value 01.01. It is a practical speed trim input, as for example from a dancer arm in tension control, or can be used to set a " creep " or minimum speed.

01.05 : Inch reference

Range : ± 1000 .

Default : +050.

Becomes the source of speed reference when selected by 01.13 (controlled in default by terminals TB3-22 and TB3-23). It provides the convenient facility to set a speed demand different from (and usually less than) the ordinary speed reference. Must be less than the maxima set by 01.06 and 01.09.

01.06 : Maximum speed forward

Range : 0 to +1000.

Default : +1000.

Sets the upper limit of speed in the forward direction of rotation.

01.07 : Minimum speed forward

Range : 0 to +1000.

Default : +1000.

Sets the lower limit of speed in the forward direction of rotation. The speed minima are disabled if bipolar selector 01.10 = 1 to prevent oscillation between the forward and reverse minimum speeds when the input speed reference is zero.

01.08 : Minimum speed reverse

Range : -1000 to 0.

Default : -1000.

Sets the lower limit of speed in the reverse direction of rotation. The speed minima are disabled if bipolar selector 01.10 = 1 to prevent oscillation between the forward and reverse minimum speeds when the input speed reference is zero.

01.09 : Maximum speed reverse

Range : -1000 to 0.

Default : -1000.

Sets the upper limit of speed in the reverse direction of rotation.

01.10 : Bipolar selector

Default : - 2342 = 1, bipolar mode,

- 2322 = 0, unipolar mode.

In its normal state (= 1) allows the drive to respond to a bipolar analogue speed reference (01.02) in which case the direction of rotation is determined by the bipolar signal. Positive polarity causes forward rotation ; negative polarity, reverse. When 01.10 = 0 the drive responds in a unipolar mode, negative-polarity signals being treated as a zero speed demand. Reversal of direction is then possible by 01.12 (in a four-quadrant drive).

01.11 : Reference " ON "

Default : 0, no speed reference.

Applies the speed reference to 01.03, pre-ramp reference. Defaults to zero if terminal TB3-21 (Run permit) is de-activated. Cannot be set to 1 unless terminal TB3-21 is activated. Is also subject to the status of the normal logic functions (refer to Menu 08). Controlled in default by terminals TB3-22, TB3-23, TB3-24, TB3-25.

01.12 : Reverse selector

Default : 0, reverse not selected.

Reverse select inverts the polarity of the speed reference signal. It has the effect (in a four-quadrant drive) of reversing the sense of the speed signal without regard to the nominal direction of motor rotation. Default value 01.12 = 0, inversion not applied. Controlled in default by terminals TB3-22, TB3-23, TB3-24, and TB3-25.

01.13 : Inch selector

Default : 0, inch not selected.

Inch select replaces all other speed demand references by the inch reference 01.05. Default value 01.13 = 0, normal speed reference applied. Controlled in default by terminals TB3-22, TB3-23.

Three-phase controllers

DMV 2322 / DMV 2342

01.14 : Reference selector 1

Default : 0.

Selects references 1 and 3 or references 2 and 4.

The two reference selectors 01.14 and 01.15 in combination enable any one of the four speed references 01.17 to 01.20 to be selected.

01.15 : Reference selector 2

Default : 0.

Selects references 1/2 or references 3/4.

The two reference selectors 01.14 and 01.15 in combination enable any one of the four internal speed reference 01.17 to 01.20 to be selected.

01.16 : Zero reference interlock

Default : 0, inhibit not applied.

Inhibits the starting of the drive until the analogue speed reference, external or internal, is near to zero.

-16 < 01.01 < +16 (values in 0.1 % of full speed).

This facility is convenient in applications where for safety or process reasons the operator determines speed by observations of the process, for example extrusion, or traction drives.

01.17 - 01.18 - 01.19 - 01.20 : References 1 to 4

Defaults

Reference 1, parameter 01.17 is the default destination of the external speed reference (terminal TB1-3) through the programmable input 07.15.

References 3 and 4, parameters 01.19 and 01.20, default to programmable inputs GP2 (TB1-5) and GP3 (TB1-6) respectively.

Reference 2, parameter 01.18, default +300.

Three-phase controllers

DMV 2322 / DMV 2342

3.3.2 - Menu 02 : Ramps

The principal alternatives available for setting ramps are as follows.

- 1 - No ramps at all, bypassing the ramp functions.
- 2 - A selection of forward and reverse ramps for normal run conditions and an optional separate ramp for inching. The arrangement for selecting running ramps affords the maximum flexibility. There are two possible ramp values available for each mode of operation, eg forward accelerations 1 and 2, forward decelerations 1 and 2, and so on. A common ramp selector enables switching between the two groups (all the 1s or all the 2s).

In addition it is possible to change ramps 1 and 2 of any quadrant within the common selection. Ramp selectors may be controlled by any of the programmable inputs.

To activate the inch ramp, a " select " signal is required from 01.13 in addition to the " enable " function 02.13.

The ramp operation can be interrupted by the ramp hold parameter, which holds the ramp output at its present value when set to 1. Ramp disable over-rides this feature.

The value of the speed reference signal after the ramp is monitored by the post-ramp reference.

3.3.2.1 - List of parameters Menu 02

RO = Read Only.

R/W = Read/Write.

A = Analog.

L = Logic.

Level 0 et 1

Parameter	Description	Acces level	Type RO / R/W	Variable A/L	Range	Default
02.01	Post-ramp reference	-	RO	A	± 1000	
02.02	Ramp enable	1	R/W	L	0 or 1	1
02.03	Ramp hold	1	R/W	L	0 or 1	0
02.04	Forward acceleration 1	0	R/W	A	0 to 1999	+050
02.05	Forward deceleration 1	0	R/W	A	0 to 1999	+050
02.06	Reverse deceleration 1	0	R/W	A	0 to 1999	(2342) +050 (2322) 000
02.07	Reverse acceleration 1	0	R/W	A	0 to 1999	(2342) +050 (2322) 000

Level 2

Parameter	Description	Acces level	Type RO / R/W	Variable A/L	Range	Default
02.08	Forward acceleration 2	2	R/W	A	0 to 1999	+100
02.09	Forward deceleration 2	2	R/W	A	0 to 1999	+100
02.10	Reverse deceleration 2	2	R/W	A	0 to 1999	(2342) +100 (2322) 000
02.11	Reverse acceleration 2	2	R/W	A	0 to 1999	(2342) +100 (2322) 000
02.12	Inch ramp rate	2	R/W	A	0 to 1999	+100
02.13	Enable inch ramp	2	R/W	L	0 or 1	0
02.14	Forward acceleration selector	2	R/W	L	0 or 1	0
02.15	Forward deceleration selector	2	R/W	L	0 or 1	0
02.16	Reverse deceleration selector	2	R/W	L	0 or 1	0
02.17	Reverse acceletation selector	2	R/W	L	0 or 1	0
02.18	Common ramp selector	2	R/W	L	0 or 1	0
02.19	Reserved		R/W		0 or 1	0

Three-phase controllers

DMV 2322 / DMV 2342

3.3.2.2 - Menu 02 parameters description

- ◇ RO (Read Only)
- R/W (Read/Write)

◇ 02.01 : Post-ramp reference

Range : ± 1000 rpm.

Monitors the value of the speed reference after it has bypassed or been modified by the ramp selected.

□ 02.02 : Ramp enable

Default : 1, enabled.

If set to disable, makes the post-ramp speed reference 02.01 equal to the pre-ramp speed reference 01.03, effectively bypassing the ramp functions.

□ 02.03 : Ramp hold

Default : 0.

Holds the ramp output at its present value when set to 1. By using a programmable input to control this parameter, the speed of the drive may be controlled from " increase " and " decrease " pushbuttons instead of a potentiometer or other continuously-variable reference source.

□ 02.04 - 02.05 - 02.06 - 02.07

Group 1 Forward, acceleration & deceleration, Reverse, deceleration & acceleration.

Range : 0 to 1999 tenths of seconds.

Default : +050 = 5s.

Defines the time taken to accelerate from rest to maximum full-scale speed (01.03 = 1000), or to decelerate from this speed to rest, as appropriate.

□ 02.08 - 02.09 - 02.10 - 02.11

Group 2 Forward, acceleration & deceleration, Reverse, deceleration & acceleration.

Range : 0 to 1999 tenths of seconds.

Default : +100 = 10s.

□ 02.12 : Inch ramp rate

Range : 0 to 1999 tenths of seconds.

Default : +100 = 10s.

To select, 02.13 = 1. Defines the rate of acceleration and deceleration when the Inch Reference is selected (01.13 = 1).

□ 02.13 : Enable inch ramp

Default : 0, disable.

Selects a dedicated ramp rate (defined by 02.12) when inching. If not selected, the normal ramps 02.04 through to 02.11 are used for inching as well as running.

□ 02.14 - 02.15 - 02.16 - 02.17

Forward, acceleration & deceleration, Reverse, deceleration & acceleration (select from group 1 or 2).

Default : 0, Ramp 1.

These selectors enable ramps to be chosen from either of the two groups at will, permitting individual acceleration and/or deceleration rates to be changed on receipt of an appropriate command.

□ 02.18 : Common ramp select

Default : 0, Group 1.

Enables selection between all ramps of Group 1 if 02.14 to 02.17 = 0, or all of Group 2.

Three-phase controllers

DMV 2322 / DMV 2342

3.3.3 - Menu 03 : Feedback Selection and Speed Loop

The principal inputs are the post-ramp reference 02.01 and the hard speed reference 03.18. The post-ramp reference can be summed with or replaced by the hard speed reference. The speed reference can, alternatively, be the hard speed reference alone. The selected input can be modified by the addition of an offset, which may be zero. The result of this summation is the final speed demand (03.01) which is added algebraically to the speed feedback to become the speed error (03.06). The speed error is finally proportioned by the PID function to become the speed loop output.

Speed feedback is derived from one of three possible sources, encoder, tachogenerator or armature voltage. Whichever source is selected becomes the speed feedback (03.02).

If the armature voltage is selected it is first summed with the IR compensation (03.05), which is derived from the integral function of the speed error and the IR compensation factor and is then either added to or subtracted from the scaled armature voltage feedback according to whether IR compensation or IR droop is selected.

The armature voltage feedback is passed to a comparator to provide a voltage clamp, used internally to prevent armature overvoltage. This clamp is used only if the armature voltage has not been selected as the feedback. Parameter 03.15 becomes the clamp level.

The speed feedback value is used for two further purpose, to supply a speed indication in rpm, and to indicate zero speed.

3.3.3.1 - List of parameters Menu 03

RO = Read Only.

R/W = Read/Write.

A = Analog.

L = Logic.

Level 0 et 1

Parameter	Description	Acces level	Type RO / R/W	Variable A/L	Range	Default
03.01	Final speed demand	-	RO	A	± 1000	
03.02	Speed feedback	-	RO	A	± 1000	
03.03	Speed feedback (rpm)	-	RO	A	± 1999 rpm	
03.04	Armature voltage	1	RO	A	± 1000	
03.05	IR compensation output	1	RO	A	± 1000	
03.06	Speed error	-	RO	A	± 1000	
03.07	Speed loop output	-	RO	A	± 1000	
03.08	Speed error integral	1	RO	A	± 1000	
03.09	Speed loop P gain	0	R/W	A	0 to 255	080
03.10	Speed loop I gain	0	R/W	A	0 to 255	040
03.11	Speed loop D gain	0	R/W	A	0 to 255	0
03.12	Digital feedback selector	1	R/W	L	0 or 1	0
03.13	AV analogue feedback selector	1	R/W	L	0 or 1	0
03.14	Feedback encoder scaling	0	R/W	A	0 to 1999	+419
03.15	Maximum armature voltage	0	R/W	A	0 to 1000	+600
03.16	Maximum speed (scaling rpm)	0	R/W	A	0 to 1999	+1750
03.17	IR compensation	0	R/W	A	0 to 255	000

Three-phase controllers

DMV 2322 / DMV 2342

Level 2

Parameter	Description	Access level	Type RO / R/W	Variable A/L	Range	Default
03.18	Hard speed reference	2	R/W	A	± 1000	(07.11)
03.19	Hard speed reference selector	2	R/W	L	0 or 1	0
03.20	IR droop selector	2	R/W	L	0 or 1	0
03.21	Ramp output selector	2	R/W	L	0 or 1	1
03.22	Speed offset fine	2	R/W	A	0 to 255	128
03.23	Zero speed threshold	2	R/W	A	0 to 255	16
03.24	D-term source	2	R/W	A	1 to 3	1
03.25	Speed error filter	2	R/W	A	0 to 255	128
03.26	Tacho input	2	RO	A	± 1000	

3.3.3.2 - Menu 03 parameters description

- ◇ RO (Read Only)
- R/W (Read/Write)

◇ 03.01 : Final speed demand

Range : ± 1000.

Monitors the value of the speed reference after it has bypassed or been modified by the ramps and/or by the hard speed reference (03.18) and speed offset fine (03.22). It is the speed reference which is presented to the speed control loop of the drive via the speed summation point.

◇ 03.02 : Speed feedback

Range : ± 1000.

Monitors the value of the speed feedback, derived from one of the following three sources (encoder, tachogenerator, or armature voltage). The selection is controlled by 03.12 and 03.13. The value is used for the closed-loop speed control of the motor. Scaling of the encoder signal is set by 03.14, and of the armature voltage feedback is controlled by the setting of maximum armature voltage 03.15. A potentiometer is provided for scaling the tachogenerator feedback signal. The speed feedback 03.02 is summed with the final speed demand 03.01 at the speed loop summation point.

◇ 03.03 : Speed feedback

Range : ± 1999 rpm

Scaled value of motor speed feedback for external information. Requires correct setting of 03.16, maximum speed.

◇ 03.04 : Armature voltage

Range : ± 1000 (direct reading in Volts).

◇ 03.05 : IR compensation output

Range : ± 1000.

The result of selected value of IR compensation 03.17 acting on the speed loop integral output.

◇ 03.06 : Speed error

Range : ± 1000.

The result of the summation of the final speed demand and the speed feedback, after filtering.

◇ 03.07 : Speed loop output

Range : ± 1000.

Speed demand forward to become current demand (menu 04).

◇ 03.08 : Speed error integral

Range : ±1000.

The integrated value of the speed error 03.06, used as input to the IR compensation calculation when using armature voltage feedback (AVF).

□ 03.09 : Speed loop proportional gain

Range : 0 to 255.

Default : 080.

The factor by which the speed error is multiplied to produce the correction term.

$$\text{Factor} = \frac{\text{Value of 03.06}}{8}$$

Increasing this value increases both the system damping and the transient speed response, and if made too high for a given load the system will become unstable. The optimum setting is the highest value possible before instability starts to occur. Optimum speed loop performance is achieved by judicious combination of all three gains of the PID algorithm.

□ 03.10 : Speed loop integral gain

Range : 0 to 255.

Default : 040.

The factor by which the speed error is multiplied to produce the correction term.

$$\text{Factor} = \frac{6f \times (03.10)}{256}$$

Where f = supply frequency.

This term ensures zero speed error during steady state load conditions increasing the value increases the rate of recovery after a disturbance. If the term is made too high, speed tends to oscillate instead of settling quickly. The optimum setting is the highest value possible before oscillation starts to occur. Optimum speed loop performance is achieved by judicious combination of all three gains of the PID algorithm.

Three-phase controllers

DMV 2322 / DMV 2342

03.11 : Speed loop derivative gain

Range : 0 to 255.

Default : 0.

The factor by which the speed error is multiplied to produce the correction term. There are three possible sources of input to this term (either final speed demand 03.01, speed feedback 03.02, or speed error 03.06). The selector is 03.24. The derivative term is a function of the rate of change of value of the input.

If the input is the speed error 03.06, output is negative if speed error is increasing. This has a damping effect.

If the input is the final speed demand 03.01, output is positive when the final speed demand is increasing. This is called " velocity feed forward ".

If the input is the speed feedback 03.02, output is negative if speed feedback is increasing. This also has a damping effect, but dependent on the changing value of the speed feedback only, not the speed reference.

03.12 : Digital feedback selector

Default : 0, analogue feedback selected.

Set to 1 to select encoder feedback. Set to 0 to select analogue feedback.

03.13 : Armature voltage / external analogue feedback selector

Default : 0, analogue feedback selected.

Determines the type of analogue speed feedback when 03.12 is set to 0. Set to 1 to select armature voltage feedback. Default setting selects analogue feedback from a tachogenerator or equivalent external source connected to terminal TB1 - 09.

03.14 : Encoder feedback scaling

Range : 0 to 1999.

Default : +419.

The value should be set to correspond with the maximum speed of the motor and with the number of lines-per-revolution of the encoder. To calculate the scale factor.

$$\text{Scale factor} = \frac{750 \times 10^6}{N \times n}$$

Where:

N = number of lines-per-revolution (encoder)

n = maximum speed of motor in rpm.

Default value is determined on the basis of a 1024-line encoder, and a maximum speed of 1750 rpm.

03.15 : Maximum armature Volts

Range : 0 to 1000.

Default : +600 (2342) or
+600 (2322).

Defines the maximum voltage permitted to be applied to the armature. When armature voltage is the selected feedback (03.12 = 0 and 03.13 = 1), the maximum armature voltage value is used for scaling the armature voltage measurement so that speed feedback is full scale at maximum voltage. If the speed feedback is derived from an encoder or tachogenerator, the armature voltage is continuously monitored, and a clamp is applied when the voltage exceeds that set in 03.15.

This can be used to prevent the voltage rising above a set level.

03.16 : Maximum speed

Range : 0 to 1999.

Default : +1750.

Used only to scale the speed feedback so that the value displayed in 03.03 is actual speed in rpm. The value applied to 03.16 should be the maximum speed in rpm (divided by ten if the maximum speed is > 1999 rpm, speed displayed in 03.03 is then rpm + 10).

03.17 : IR compensation

Range : 0 to 255.

Default : 000.

$$\text{Value of 03.05} = \frac{(03.08) \times (03.17)}{2048}$$

This value is used to calculate the compensation for the resistive voltage-drop of the armature to improve speed control with varying loads when the selected speed feedback is the armature voltage.

IR compensation is a positive feedback, and may give rise to instability if set too high. Furthermore, modern laminated-frame motors have typically a rising load-speed characteristic which is unsuited to armature voltage feedback with IR compensation. IR compensation is more suited to compound-wound motors with a flat (not rising) load-speed characteristic.

The integral of the speed error is used as the input to IR compensation rather than current feedback because it is the most smooth of the variables, in speed control, the value of the speed error integral is the steady-state value of current demand.

03.18 : Hard speed reference

Range : ± 1000.

Default : (07.11).

Speed reference fed into the speed loop without passing through the ramps.

03.19 : Hard speed reference selector

Default : 0.

If 03.19 is set to 1, and ref. " ON " (01.11) = 1, the hard speed reference (3.18) is added at the speed loop summation point.

03.20 : IR droop selector

Default : 0.

If 03.20 = 1 when using armature voltage as the speed feedback, speed will decrease as load increases.

A typical application, for example, is a mechanical blanking press fitted with a heavy flywheel. Applying IR droop prevents the drive from delivering a sudden increase of current at the moment of impact (sudden increase of torque demand). It is better that the drive should deliver energy to the flywheel during the whole operating cycle rather than mostly at the moment of impact.

Three-phase controllers

DMV 2322 / DMV 2342

03.21 : Ramp output selector

Default : 1

When 03.21 = 1, ramp output is added at the speed loop summation point.

03.22 : Speed offset fine

Range : 0 to 255.

Default : 128.

Used as a fine trim on the speed reference signal to correct, or introduce, a small offset.

$$\text{Value} = \frac{(03.22) - 128}{16}$$

03.23 : Zero speed threshold

Range : 0 to 255.

Default : 16.

The threshold may be adjusted to any value up to 25.5 % of maximum speed. Refer also to 10.09.

03.24 : Derivative term source

Range : 1, 2 or 3.

Default : 1.

The derivative term of the PID in the speed loop may use one of three sources.

1 = speed error 03.06.

Damping changes in speed demand and feedback.

2 = speed reference 03.01.

Velocity feed-forward.

3 = speed feedback 03.02.

Damping on feedback only (" feedback forcing ").

03.25 : Speed error filter

Range : 0 to 255.

Default : 128.

$$\text{Filter time-constant} = \frac{256}{6f \times (03.25)}$$

Where : f = supply frequency.

A low-pass filter to reduce the effect on the speed error signal (03.04) of interference (from a noisy tachogenerator, for example).

03.26 : Tachogenerator input

Range : ± 1000 .

Monitors the tacho input measurement. The tacho potentiometer is used to scale the feedback signal such that at full motor speed, 03.26 = 1000. Units displayed = 0.1 % of full speed per increment.

Three-phase controllers

DMV 2322 / DMV 2342

3.3.4 - Menu 04 : Current selection and limits

The principal input is the speed loop output 03.07 in combination, for torque or current-control modes, with the torque reference 04.08. These inputs become the current demand to which an offset or trim option may be applied. The result is then subject to an over-riding limitation derived from several sources including the speed feedback.

Six bit-parameters determine the mode of control (speed control, current control, number of quadrants, etc).

A feature in this menu is the facility to apply a second current limit (04.07) automatically (refer to 04.10, 04.18 and 04.19) which enable current limit 2 to be applied after a chosen time delay. This is appropriate to applications where the initial load torque on start-up is high, but after some period becomes less, as with some mechanical mixing processes, for example.

3.3.4.1 - List of parameters Menu 04

RO = Read Only.

R/W = Read/Write.

A = Analog.

L = Logic.

Level 0 et 1

Parameter	Description	Acces level	Type RO / R/W	Variable A/L	Range	Default
04.01	Current demand	-	RO	A	± 1000	
04.02	Final current demand	-	RO	A	± 1000	
04.03	Over-riding current limit	-	RO	A	± 1000	
04.04	I limit (taper start point)	1	R/W	A	0 to 1000	+1000
04.05	I limit Bridge 1	0	R/W	A	0 to 1000	+1000
04.06	I limit Bridge 2	0	R/W	A	0 to 1000	(2342) +1000 (2322) 000

Level 2

Parameter	Description	Acces level	Type RO / R/W	Variable A/L	Range	Default
04.07	I limit 2	2	R/W	A	0 to 1000	+1000
04.08	Torque reference	2	R/W	A	± 1000	+000
04.09	Current offset	2	R/W	A	± 1000	+000
04.10	I limit 2 selector	2	R/W	L	0 or 1	0
04.11	Current offset selector	2	R/W	L	0 or 1	0
04.12	Mode bit 0	2	R/W	L	0 or 1	0
04.13	Mode bit 1	2	R/W	L	0 or 1	0
04.14	Quadrant 1 enable	2	R/W	L	0 or 1	1
04.15	Quadrant 4 enable	2	R/W	L	0 or 1	(2342) 1 (2322) 0
04.16	Quadrant 3 enable	2	R/W	L	0 or 1	(2342) 1 (2322) 0
04.17	Quadrant 2 enable	2	R/W	L	0 or 1	(2342) 1 (2322) 0
04.18	Enable auto (I limit) change	2	R/W	L	0 or 1	0
04.19	Current limit timer	2	R/W	A	0 to 255	000
04.20	Current taper 1 threshold	2	R/W	A	0 to 1000	+1000
04.21	Current taper 2 threshold	2	R/W	A	0 to 1000	+1000
04.22	Current taper 1 slope	2	R/W	A	0 to 255	000
04.23	Current taper 2 slope	2	R/W	A	0 to 255	000
04.24	Taper 1 threshold exceeded	2	RO	L	0 or 1	
04.25	Taper 2 threshold exceeded	2	RO	L	0 or 1	

Three-phase controllers

DMV 2322 / DMV 2342

3.3.4.2 - Menu 04 parameters description

- ◇ RO (Read Only)
- R/W (Read/Write)

◇ 04.01 : Current demand

Range : ± 1000 .

The current demand signal is the controlling input to the current loop when the drive is being operated in speed-control mode. The signal is subject to limitation by 04.03, 04.05 and 04.06 before being passed to the current loop.

◇ 04.02 : Final current demand

Range : ± 1000 .

Current demand final output, to the current loop (Menu 05) after limits have been applied.

◇ 04.03 : Over-riding current limit

Range : ± 1000 .

This is the limiting value of current demand and is the result of the speed-dependent current taper calculation or I-limit 2 (if selected), whichever is the less. Refer to s. 3.4 (Menu 04)

□ 04.04 : I limit 1 (taper start point)

Range : 0 to 1000.

Default : +1000.

This parameter provides symmetrical current-limitation for bridges 1 and 2 and is the datum level from which the current taper functions operate (refer to 04.20 and 04.21). I limit 1 can be used in application where the motor kW rating is somewhat less than that of the drive, as an alternative to changing the fixed current-burden resistors.

□ 04.05 : I limit Bridge 1

Range : 0 to 1000.

Default : +1000.

Determines the maximum limit of current demand when bridge 1, the " positive " bridge, is conducting. It causes any demand for current in excess of the limit set point to be ignored.

□ 04.06 : I limit Bridge 2

Range : 0 to 1000.

Default : +1000.

Determines the maximum limit of current demand when bridge 2, the " negative " bridge, is conducting. It causes any demand for current in excess of the limit set point to be ignored.

□ 04.07 : I limit 2

Range : 0 to 1000.

Default : +1000.

Available as an additional current limit. Applies to both bridges. The drive can be programmed, if desired, to select 04.05 automatically at a programmed time interval after a RUN signal. Refer to 04.10, 04.18 and 04.19.

□ 04.08 : Torque reference

Range : ± 1000 .

Default : +000.

This value is an input to the current loop and can be selected for use in applications requiring direct control of current (motor torque).

□ 04.09 : Current offset

Range : ± 1000 .

Default : +000.

Current offset is used to apply a trim to the current demand 04.01.

□ 04.10 : I limit 2 selector

Default : 0

Set 04.10 = 1 to select I limit 2. Can be caused to change automatically. (Refer to 04.18 and 04.19).

□ 04.11 : Current offset selector

Default : 0.

Set 04.11 = 1 to select current offset.

□ 04.12 : Mode bit 0

Default : 0, not selected.

Set 04.12 = 1 to select. Operates in conjunction with 04.13 to configure the drive for speed control or any of three modes of torque control. (Refer to 04.13).

□ 04.13 : Mode bit 1

Default : 0, not selected.

Set 04.13 = 1 to select. Operates in conjunction with 04.12 to configure the drive for speed control or any of three modes of torque control, as follows.

04.12 = 0 and 04.13 = 0. Speed mode control (normal configuration).

04.12 = 1 and 04.13 = 0. Basic current or torque-control mode.

In this mode, the torque reference 04.08 is the input to the current loop and is subject to the limitations of the over-riding current limit 04.03, the Bridge 1 and Bridge 2 limits 04.05 and 04.06, and to the current slew rate 05.04.

04.12 = 0 and 04.13 = 1. Torque-control mode with speed over-ride. Refer to fig. 18 and 19.

In this mode, the output of the speed loop is clamped either to the value of the torque reference 04.08, or to zero according to whether the speed error

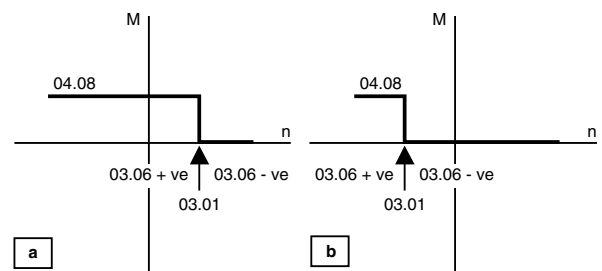

18 Torque control with speed over-ride. Positive torque reference.

a - Forward drive.

b - Reverse braking.

Positive torque, forward drive and reverse braking, is applied at the value of 03.01 when the speed error 03.06 is positive. When the speed error is negative, torque is zero.

Three-phase controllers

DMV 2322 / DMV 2342

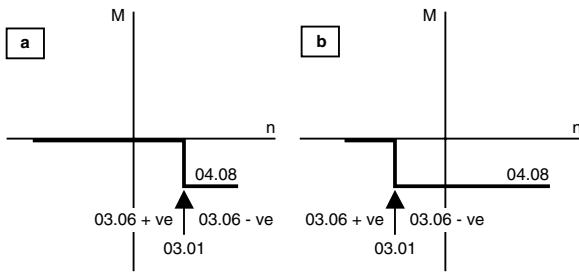

19 Torque control with speed over-ride. Negative torque reference.

- a - Forward braking.
- b - Reverse drive.

Negative torque, forward braking and reverse drive, is applied at the value of 03.01 when the speed error 03.06 is negative. When the speed error is positive, torque is zero.

03.06 is positive or negative, and depending on whether the torque reference is positive or negative, ie dependent on relative polarities.

In the two motoring quadrants, speed is limited to the value of the final speed demand 03.01, preventing uncontrolled increase of speed when load is removed. The drive should be adjusted to run at a slight overspeed when off load, in order to ensure adequate current demand at all speeds.

In the two regenerative quadrants, the current demand set by torque reference 04.08 is disabled when speed is less than that set by the final speed demand 03.01. This prevents the reducing load torque resulting in reversal of rotation. The value of 03.01 should be zero.

A disadvantage of this mode is that it cannot provide torque at a particular speed both accelerating and decelerating. Parameter 04.08 behaves as a controllable current limit in this mode.

04.12 = 1 and 04.13 = 1. Coiler/uncoiler control mode. Refer to fig. 20 and 21.

This mode allows torque to be applied in either sense, for acceleration or deceleration, while preventing uncontrolled increase in speed or reversal if the load becomes zero. When the torque demand is in the sense opposite to that of speed feedback, this mode automatically selects zero speed reference.

For a coiler, the offset 01.04 should be set just slightly positive so that 03.01 is greater than the line speed reference. When a full reel (of a coiler) is decelerating, the torque demand may be negative. Since the speed feedback is positive, the speed reference is automatically made zero so that the speed error becomes negative. Both torque demand and speed error being negative, decelerating torque is applied.

For an uncoiler, the offset 01.04 should be set just slightly negative so that there is a negative speed error at zero speed. (Negative speed error is necessary to produce a negative torque to maintain tension at zero speed). As the line speed reference increases, 03.01 becomes positive.

A suitable scaling of the input should be applied such that 03.01 is always greater than the speed feedback, thus maintaining a positive speed error 03.06. Since the speed feedback is positive, zero speed is automatically selected whenever the torque demand is negative (normal operation) but if the torque demand becomes positive then the value of 03.01 becomes the speed demand, and accelerating torque is allowed, provided that the reel speed is not greater than 03.01.

For coiler/uncoiler applications, line speed reference corresponds to reel speed at minimum diameter.

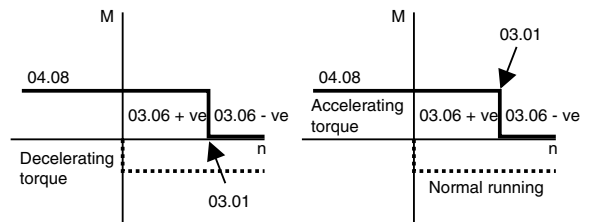

20 Coiler decelerating. -ve torque demand. 03.01 --> 0, the speed feedback being +ve.

21 Uncoiler accelerating. +ve torque demand, 03.01 is at set value. -ve torque demand (at-speed), 03.01 --> 0 automatically, to maintain tension.

04.14 : Quadrant 1 enable

Default : 1, enabled.

Quadrant 1 operation is defined as motoring in the forward direction, speed and torque both having positive values.

04.15 : Quadrant 4 enable

Default : 1, enabled for DMV 2342.

0, disabled for DMV 2322.

Quadrant 4 operation is defined as regenerating in the reverse direction, speed being negative and torque positive.

04.16 : Quadrant 3 enable

Default : 1, enabled for DMV 2342,

0, disabled for DMV 2322.

Quadrant 3 operation is defined as motoring in the reverse direction, speed and torque both having negative values.

04.17 : Quadrant 2 enable

Default : 1, enabled for DMV 2342,

0, disabled for DMV 2322.

Quadrant 2 operation is defined as regenerating in the forward direction, speed being positive and torque negative.

04.18 : Enable automatic I limit 2 change

Default : 0, disabled.

When this bit is enabled, the I limit 2 selector is automatically changed to 1 after a time interval set by 04.19. The drive can be programmed to select 04.07 automatically at a programmed time-interval (04.19) after a RUN signal.

Three-phase controllers

DMV 2322 / DMV 2342

04.19 : I limit timer

Range : 0 to 255.

Default : 000.

A time interval up to 255 seconds can be programmed. If 04.18 = 1, I limit 2 is automatically selected when the set time elapses after a RUN command. This feature is appropriate to applications WHERE THE MOTOR IS SHORT-TIME RATED, such a mixing machinery, where the starting load is high and falls to a lower, constant value only after the machine has run for some time.

04.20 : Current taper 1 threshold

Range : 0 to 1000.

Default : +1000.

Sets a threshold value of speed feedback, beyond which 04.24 changes to 1 to indicate that the threshold has been exceeded, and is the starting point for taper 1 (if implemented). Armature current reduces, as a function of speed, at a rate defined by 04.22. This parameter can also be used as a general-purpose speed threshold.

If only one taper is used, it must be Taper 1. If both are used, Taper 1 must be the first.

04.21 : Current taper 2 threshold

Range : 0 to 1000.

Default : +1000.

Sets a threshold value of speed feedback, beyond which 04.25 changes to 1 to indicate that the threshold has been exceeded, and is the starting point for taper 2 (if implemented). Armature current reduces, as a function of speed, at a rate defined by 04.23. This parameter can also be used as a general-purpose speed threshold.

04.22 : Current taper 1 slope

Range : 0 to 255.

Default : 000.

Sets the rate of change of armature I limit with respect to speed in either direction of rotation, above the threshold set by 04.20.

Scaling factor - 04.22 = $128 \frac{\Delta I_1}{\Delta n_1}$

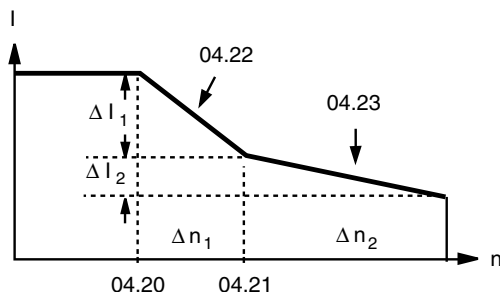

Calculation of current taper gradients 1 & 2.
Refer to text, parameters 04.22 and 04.23.

04.23 : Current taper 2 slope

Range : 0 to 255.

Default : 000.

Sets the rate of change of armature I limit with respect to speed in either direction of rotation, above the threshold set by 04.21.

Scaling factor - 04.23 = $128 \frac{\Delta I_2}{\Delta n_2}$

04.24 : Taper threshold 1 exceeded

Default : 0.

Set to 1 when the threshold set point of 04.20 is exceeded.

04.25 : Taper threshold 2 exceeded

Default : 0.

Set to 1 when the threshold set point of 04.21 is exceeded.

Three-phase controllers

DMV 2322 / DMV 2342

3.3.5 - Menu 05 : Current loop

This is the final stage in the processing of the speed and torque references and feedbacks to determine the final firing angle signal. The normal principal input is the final current demand, which is subject to the slew rate limit, summed algebraically with the current feedback and further modified by whatever settings may have been applied to the group of current loop parameters.

Current feedback, after scaling, delivers a readable signal to display actual current in amps. Current feedback also is an important function in the protection of the drive. The feedback signal is monitored in relation to the selected overload threshold, modified according to preprogrammed values for overload time. The provision of two parameters for overload timing enables settings to be applied so as to take account of the fact that the cooling time of a motor can be longer than its heating time.

3.3.5.1 - List of parameters Menu 05

RO = Read Only.
R/W = Read/Write.
A = Analog.
L = Logic.

Level 0 et 1

Parameter	Description	Acces level	Type RO / R/W	Variable A/L	Range	Default
05.01	Current feedback	-	RO	A	± 1000	
05.02	Current feedback (amps)	-	RO	A	± 1999	
05.03	Firing angle	-	RO	A	277 to 1023	
05.04	Slew rate limit	1	R/W	A	0 to 255	040
05.05	Maximum current (scaled)	0	R/W	A	0 to 1999	(rating)
05.06	Overload threshold	1	R/W	A	0 to 1000	+ 700
05.07	Overload time (heating)	1	R/W	A	0 to 255	030
05.08	Overload time (cooling)	1	R/W	A	0 to 255	050
05.09	Enable commissioning autotune	1	R/W	L	0 or 1	0

Level 2

Parameter	Description	Acces level	Type RO / R/W	Variable A/L	Range	Default
05.10	Reduced endstop	2	R/W	L	0 or 1	0
05.11	Actual overload	2	RO	A	0 to 1999	
05.12	Discontinuous I gain	2	R/W	A	0 to 255	65
05.13	Continuous P gain	2	R/W	A	0 to 255	33
05.14	Continuous I gain	2	R/W	A	0 to 255	33
05.15	Motor constant	2	R/W	A	0 to 255	50
05.16	Reserved		R/W		0 to 255	0
05.17	Inhibit firing	2	R/W	L	0 or 1	0
05.18	Standstill enable	2	R/W	L	0 or 1	1
05.19	Standstill mode	2	R/W	L	0 or 1	0
05.20	Direct firing-angle control	2	R/W	L	0 or 1	0
05.21	Bridge lockout enable (2342 - 12P)	2	R/W	L	0 or 1	0
05.22	Disable adaptive control	2	R/W	L	0 or 1	0
05.23	Enable (2322 - 12P)	2	R/W	L	0 or 1	0
05.24	Series 12P operation	2	R/W	L	0 or 1	0
05.25	Parallel 12P operation	2	R/W	L	0 or 1	0

Three-phase controllers

DMV 2322 / DMV 2342

3.3.5.2 - Menu 05 parameters description

- ◇ RO (Read Only)
- R/W (Read/Write)

◇ 05.01 : Current feedback

Range : ± 1000 .

The current feedback signal is derived from internal current transformers. It is used for closed-loop control and indication of the armature current, and to initiate motor protection.

◇ 05.02 : Current feedback (Amps)

Range : ± 1999 .

The current feedback signal, modified by the scaling factor, becomes available as an indication in amps. Refer also to 05.05.

◇ 05.03 : Firing angle

Range : 277 to 1023.

This is the output of the current loop algorithm, and the input reference to the ASIC, which generates the firing pulses. 05.03 = 1023 indicates fully "phased forward".

□ 05.04 : Slew rate limit

Range : 0 to 255.

Default : 40.

This parameter limits the maximum rate of change of current demand. Older types of motor, especially if of non-laminated construction, may have a tendency to flash over if the rate of change of current is too high for the inherent lag of the interpole windings.

Defined as :

$$S = I_{\max} \times 6f \times \frac{05.04}{256}$$

Where :

- S = slew rate in amps s^{-1} ,
- f = frequency of the power supply in Hz,
- I_{\max} = maximum current (A).

□ 05.05 : Maximum current

Range : 0 to 1999.

Default : Drive current rating.

The maximum output current, in amps, of the drive for indication purposes. Does not play any part in motor protection. The value input to 05.05 is the maximum current divided by ten if the maximum current is greater than 1999. In this cases the displayed value 05.02 will be amps + 10.

If the maximum current is < 200A, 05.05 may be set as maximum current multiplied by 10. 05.02 will then display current in units of 0.1A.

To calculate the burden resistor value :

- drive modules up to 210A output

$$R_B = \frac{400}{I_{\max}}$$

- drive modules over 210A output

$$R_B = \frac{1600}{I_{\max}}$$

Where I_{\max} is usually 150 % of full load current.

□ 05.06 : Overload threshold

Range : 0 to 1000.

Default : +700.

Sets the threshold of armature current feedback beyond which the current-time overload protection begins to integrate.

□ 05.07 : Overload integrating time (heating)

Range : 0 to 255.

Default : 030.

Integrating time for 05.06. For use in conjunction with 05.08, such that 05.07 < 05.08.

Time t to trip is :

$$t = (05.07) \times \frac{1000 - (05.06)}{(05.01) - (05.06)}$$

Refer also to Menu 10, parameter 10.18.

□ 05.08 : Overload integrating time (cooling)

Range : 0 to 255.

Default : 050.

Integrating time for 05.06. For use in conjunction with 05.07, such that 05.07 < 05.08.

Time t to trip is :

$$t = (05.08) \times \frac{1000 - (05.06)}{(05.06) - (05.01)}$$

Refer also to Menu 10, parameter 10.18.

□ 05.09 : Enable commissioning autotune

Default : 0, disabled.

To autotune the current loop during commissioning.

- Disconnect the field of the motor if a fixed field is being used. (Open terminals L11 and L12 in the European version of the drive).

Observe approved safety procedures !

- Enable autotune, set 05.09 = 1.
- Enable the drive by the input TB4-31.

When the autotune process is complete, the drive ready relay will open for 50 ms after which the autotune parameter will be automatically set to disable (05.09 = 0). The purpose of this process is to allow the autotune sequence to be started when a "run permit" is present but to return the drive to a safe condition when the autotune is complete. It may be necessary to clamp the motor shaft if it tends to rotate during this procedure.

Notes :

- 1) The foregoing assumes that the drive ready relay is interlocked with any "run permit" that is present.
- 2) If the motor is being operated with field control (Menu 06), the field will be turned off automatically.

□ 05.10 : Reduced endstop

The endstop allows the armature voltage to rise, during regeneration, to 1.16 x supply voltage. On very "soft" supplies the endstop may be too close to the crossover point. Setting 05.10 = 1 increases the safety margin but reduces the maximum regenerated armature voltage to 1.05 x supply voltage.

Three-phase controllers

DMV 2322 / DMV 2342

05.11 : Actual overload

Range : 0 to 1999.

Monitors the value of the integrating current-time overload. When the value reaches the trip point determined by 05.06, 05.07 and 05.08, an overload trip occurs. The overload trip will operate when 05.11 reaches the value given by :

$$[1000 - (05.06)] \times \frac{10}{16}$$

The rate at which 05.11 increases or decreases is controlled by the values of 05.07 and 05.08 respectively.

05.12 : Discontinuous I-gain

Range : 0 to 255.

Default : 65.

Set by the commissioning Autotune parameter 05.09.

This parameter is set to correct any errors in the prediction of firing angle in the discontinuous current region. If 05.15 is set correctly, 05.12 has little effect, but if set too high, instability can occur.

Gain applied $\frac{\text{value of 05.12}}{512}$

05.13 : Continuous P-gain

Range : 0 to 255.

Default : 33.

Set by the commissioning Autotune parameter 05.09.

This parameter enables the current loop to follow very closely a step-change in current. If set too high, there will be an overshoot. If set too low, the new current value will be achieved unduly slowly.

Gain applied $\frac{\text{value of 05.13}}{512}$

05.14 : Continuous I-gain

Range : 0 to 255.

Default : 33.

Set by the commissioning Autotune parameter 05.09. Its value will depend on the motor time-constant. Increasing the value of 05.14 will improve the response of the current loop but at the risk of instability.

Gain applied $\frac{\text{value of 05.14}}{1024}$

05.15 : Motor constant

Range : 0 to 255.

Default : 50.

This parameter is used to scale the current demand such that the control loop correctly predicts the firing angle in the discontinuous current region. It is set automatically by the commissioning autotune parameter 05.09.

05.16 : Reserved

Range : 0 to 255.

Default : 0.

05.17 : Inhibit firing

Default : 0, enabled.

If set to 1, disables thyristor firing (both bridges), and resets acceleration and deceleration ramps.

05.18 : Enable standstill logic

Default : 1, enabled.

When enabled, causes the firing angle to be fully phased back when the drive has received a STOP command and when the speed falls below 0,8 % of maximum speed. After a short time delay, the thyristors are inhibited also. This prevents " creep " and is used in applications in which there is no requirement to maintain motor torque at standstill. Refer also to 05.19.

05.19 : Standstill mode

Default : 0.

05.19 = 0, standstill logic is enabled after STOP command or zero reference.

05.19 = 1, standstill logic enabled after STOP command only.

Setting 05.19 = 1 has the effect of not enabling the standstill logic when the stopping signal is given by the reference alone. This condition therefore allows creep speeds, shaft orientation, and other functions which take place close to zero speed, whilst preventing any " creep " after a STOP command.

05.20 : Enable direct firing angle control

Default : 0, disabled.

When enabled, the firing angle 05.03 is controlled by the value of the post-ramp reference 02.01. This mode is valuable for system diagnosis, particularly where instability is present, since it allows the drive to operate without the influence of either the speed loop or the current loop, thereby eliminating their effect upon the system.

Note : This facility must be used with caution. When the reference is 02.01, there is no protection against excessive acceleration, output voltage or current other than the instantaneous overcurrent trip. Also take care to reset 05.20 = 0 after completion of tests.

05.21 : Enable Bridge 2 lockout

Default : 0, disabled.

Requires to be set only for parallel DMV 2342 12-pulse system installations comprising two drives which are to share load, to prevent one drive changing bridges while the other is still conducting.

05.22 : Disable adaptive control

Default : 0, enabled.

Setting 05.22 = 1, disables adaptive control.

When adaptive control is enabled (default status) the current loop employs two different algorithms, one of which applies high gain in the discontinuous-current region. This is unsuitable for some applications, such as non-motor loads, for which adaptive control should be disabled.

Three-phase controllers

DMV 2322 / DMV 2342

05.23 : Enable DMV 2322 series 12-pulse

Default : 0, disabled.

Enabling this function configures the drive to deliver normal and delayed firing pulses to a single 12-channel power board. Cannot be enabled if either of the Bridge 2 quadrants 04.16 and 04.17 are enabled.

In 6-pulse thyristor drives, the current drawn from each phase of the supply is not continuous. Out of each 180° of the ac supply cycle, full load current is drawn for 120° and none for the remaining 60°. This imposes a degree of harmonic distortion on the supply.

Twelve-pulse thyristor drives draw current for the full 360° of the ac supply cycle, and the current waveform approximates very closely to a sine wave, with much-reduced distortion as a result.

A further advantage is the much smoother dc current output from 12-pulse drives, which is a benefit in many applications.

Two 12-channel power boards are driven by pcb MDA1 for DMV 2342 12 pulse.

05.24 : Series 12-pulse operation

Default : 0, disabled.

This parameter should be set for operation in either two (or four) quadrant 12-pulse mode. Parameter 05.23 (see above) is read by the software only at power-on and during a cyclic reset (a reset when the drive is disabled). If either of the Bridge 2 quadrants is enabled when 05.24 is read, the outputs are not diverted within the ASIC and 05.24 is set to 0.

Note : Series 12-pulse mode is phase-sensitive. The rotation on the stacks must be in the sequence L1, L2, L3 (10.11 = 1).

05.25 : Parallel 12-pulse operation

Default : 0, disabled.

This parameter instructs the drive to operate in parallel 12-pulse mode and should be set for operation in either two (or four) quadrant mode. For 4-quadrant operation, parameter 05.21 (see above) must be set to 1 and the F10 input of each drive must be connected to the ST5 output of the other. Also, the control 0V terminals of both drives must be connected.

Three-phase controllers

DMV 2322 / DMV 2342

3.3.6 - Menu 06 : Field control

The **DMV 2322 / DMV 2342** is equipped with field control as part of the on-board software. If a motor is being used with an uncontrolled (" fixed ") field supply, this menu does not apply.

Provision is made for programming two selectable values of maximum field current. Further, the lower value of maximum field current can be controlled by a programmable timer so that, when the drive is not running, the field can be switched automatically to economy mode.

The resulting field current demand is summed algebraically with the field current feedback to produce a current error which is the input to the field current loop. The output of the field current loop is the firing angle, subject to the front endstop limit.

The field current can alternatively be controlled directly by either of the maximum field parameters 06.08 and 06.09 via a programmable input or by application software, and there is a facility for direct control of the firing angle, useful for diagnosis.

The principal inputs in spillover mode are, from the internal logic, the armature voltage, from external input, a set point for back-emf.

Field current demand is the output of the back-emf voltage loop, subject to programmed maximum and minimum field current values. The voltage loop compares the calculated back-emf value with a programmed set point which is used as factor in determining field current demand. The voltage loop output, and consequently the field current demand, is maximum when the calculated back-emf is less than the setpoint value. When the calculated value exceeds the set point value (at base speed) the voltage loop reduces the field current demand to regulate the calculated back-emf to the set point value.

Alternatively, the user may wish not to use the voltage loop, but to enter a current demand directly. The user can set two maximum field current parameter values. In this mode, the value of the back-emf set point should be set to maximum, such that the voltage loop always demands maximum field current. The current demand is then the selected maximum field current parameter.

3.3.6.1 - List of parameters Menu 06

RO = Read Only.

R/W = Read/Write.

A = Analog.

L = Logic.

Level 0 et 1

Parameter	Description	Acces level	Type RO / R/W	Variable A/L	Range	Default
06.01	Back-emf	-	RO	A	0 to 1000	
06.02	Field-current demand	-	RO	A	0 to 1000	
06.03	Field-current feedback	-	RO	A	0 to 1000	
06.04	Firing angle	-	RO	A	261 to 1000	
06.05	IR compensation 2 output	-	RO	A	± 1000	
06.06	IR compensation 2	0	R/W	A	0 to 255	000
06.07	Back emf set point	0	R/W	A	0 to 1000	+400
06.08	Maximum field current 1	0	R/W	A	0 to 1000	+1000
06.09	Maximum field current 2	1	R/W	A	0 to 1000	+500
06.10	Minimum field current	0	R/W	A	0 to 1000	+500
06.11	Field feedback scaling	1	R/W	A	0 to 112	+110
06.12	Field economy time-out	1	R/W	A	0 to 255	030
06.13	Enable field control	1	R/W	L	0 or 1	0
06.14	Maximum field 2 selector	1	R/W	L	0 or 1	0
06.15	Enable field economy time-out	1	R/W	L	0 or 1	0
06.16	Field time-constant selector	1	R/W	L	0 or 1	0
06.17	Voltage loop integral gain	1	R/W	L	0 or 1	0

Level 2

Parameter	Description	Acces level	Type RO / R/W	Variable A/L	Range	Default
06.18	Enable speed gain adjustment	2	R/W	L	0 or 1	0
06.19	Direct firing angle control	2	R/W	L	0 or 1	0
06.20	Select alternative IR compensation 2	2	R/W	L	0 or 1	0
06.21	Firing angle front endstop	2	R/W	A	0 to 1000	+1000

Three-phase controllers

DMV 2322 / DMV 2342

3.3.6.2 - Menu 06 parameters description

- RO (Read Only)
- R/W (Read/Write)

06.01 : Back EMF

Range : 0 to 1000.
The calculated motor back emf based on armature voltage minus IR compensation value 2, 06.05. Feedback to the emf loop in spillover mode.

06.02 : Field current demand

Range : 0 to 1000.
The current demand from the emf loop, subject to the limits of 06.08, 06.09 and 06.10.

06.03 : Field current feedback

Range : 0 to 1000.
Feedback to the field current loop.

06.04 : Firing angle

Range : 261 to 1000.
Scaling : 06.04 = 1000 corresponds to " fully phased forward ".

06.05 : IR compensation 2 output

Range : ± 1000.
The value resulting from the application of 06.06 to the speed error integral input.

06.06 : IR compensation 2

Range : 0 to 255.
Default : 000.
A programmable factor used for calculation of the armature IR-drop as correction to measured armature voltage, to enable the back emf to be computed.

$$06.05 = \frac{(03.08) \times (06.06)}{2048}$$

06.07 : Back EMF set point

Range : 0 to 1000.
Default : +400.
The programmable value of the armature back emf in volts, at which the field begins to weaken. Defined as the voltage at which base speed is reached.

06.08 : Maximum field current 1

Range : 0 to 1000.
Default : +1000.
Programmable value of the maximum current demand of the emf loop. If the field control is to be used in current mode, this parameter would become the current reference of the field control loop, and the back emf set point should normally be set to maximum to prevent spillover occurring ; alternatively, if motor overvoltage protection by spillover is required, the back emf set point should be set to maximum armature voltage.

06.09 : Maximum field current 2

Range : 0 to 1000.
Default : +500.
Alternative to 06.07, for use as an economy setting. Refer to 06.12, 06.14 and 06.15.

06.10 : Minimum field current

Range : 0 to 1000.
Default : +500.
The minimum value of current demand, to prevent excessive field weakening, for example with overhauling loads.

06.11 : Field feedback scaling

Range : 0 to 112.
Default : +110.
The MDA3 card has a fixed burden resistor. Parameter 06.11 permits the user to apply a scaling factor to the current feedback. Output is the value 06.03.

EXC - DMV 8		
06.11	Field current	J1 position
201	0.5	2A
202	1.0	2A
203	1.5	2A
204	2.0	2A
205	2.5	8A
206	3.0	8A
207	3.5	8A
208	4.0	8A
209	4.5	8A
210	5.0	8A
211	5.5	8A
212	6.0	8A
213	6.5	8A
214	7.0	8A
215	7.5	8A
216	8.0	8A

06.12 : Field economy timeout

Range : 0 to 255.
Default : 030.
Permits the drive to be configured to select maximum field 2 (a reduced setting) automatically after the drive has been disabled for a period (in seconds) defined by the value chosen for this parameter. Provided so that the windings do not overheat if the drive is stopped and the motor ventilation is switched off, or to maintain a reduced level of field current to prevent condensation when the motor is not in use.

06.13 : Enable field control

Default : 0, disabled.

06.14 : Maximum field 2 selector

Default : 0, disabled.
Set to 1 to engage maximum field 2. Controlled automatically by field economy timeout function if 06.15 is set to 1. Maximum field 2 is selected after a time delay (refer to 06.12) when a drive disable signal is given.

Three-phase controllers

DMV 2322 / DMV 2342

06.15 : Enable field economy timeout

Default : 0, disabled.

When enabled (=1), parameter 06.14 is automatically controlled by the field economy timeout function when a drive enable signal is removed. When the timeout is disabled, parameter 06.14 becomes user R/W.

06.16 : Field time-constant selector

Default : 0, disabled.

Set 06.16 = 1 for time constant > 0.3 sec.

Set 06.16 = 0 for time constant < 0.3 sec (default).

06.17 : Voltage loop integral gain

Default : 0, disabled.

Set 06.17 = 1 to double the integral gain if less overshoot is desired.

06.18 : Enable speed gain adjustment

Default : 0, disabled.

This parameter adjusts the speed loop gains (menu 03) to compensate for the weakening of the field flux in field control mode so that the torque response remains substantially constant throughout the whole speed range.

Defined as :

$$G = \frac{06.08}{06.02}$$

Where G = Speed loop gain adjustment factor.

06.19 : Direct firing angle control

Default : 0, disabled.

Enables 06.08 to control the firing angle directly, subject only to the front endstop. Permits operation without the voltage or the current loop, for the purpose of diagnosis.

Note : In this mode there is **no protection** against excessive field voltage and current.

06.20 : Alternative IR compensation 2 selector

Default : 0, 03.08,

1 = 01.20 (ref. 4).

Determines the source of the IR compensation 2. The source selection may be either the speed error integral (03.08) or the hard speed reference, ref. 4 (01.20).

06.21 : Firing angle front endstop

Range : 0 to 1000.

Default : +1000.

Restricts the advance of the firing angle in cases where 180° advance would result in overvoltage being applied to the field windings.

Three-phase controllers

DMV 2322 / DMV 2342

3.3.7 - Menu 07 : Analogue inputs & outputs

Scaling parameters have a multiplying range from 0.001 to 1.999 (a multiplier of zero would give the parameter a null value).

Source and destination parameters define a parameter to be used as either input or output, thereby defining the function of the programmable input and output terminals. Menu 07 contains three analogue - input/output groupings. There are two separate groups of analogue input. The first is a 12-bit analogue input which is normally used as the speed reference input (refer to s. 3.4 Menu 01), but can alternatively be programmed to any real R/W destination.

High accuracy is achieved by voltage-to-frequency conversion. The terminal can be programmed as a voltage input or as a current loop input, with options 0-20mA, 20-0mA, 4-20mA or 20-4mA.

The second group provides a flexible means for scaling and assigning destinations to the four general purpose inputs GP1, GP2, GP3 and GP4, all of which are 10-bit resolution.

Finally, three analogue outputs, via digital-to-analogue (DAC) converters, feature programmable-source parameters and scaling.

3.3.7.1 - List of parameters Menu 07

RO = Read Only.

R/W = Read/Write.

A = Analog.

L = Logic.

Level 1

Parameter	Description	Acces level	Type RO / R/W	Variable A/L	Range	Default
07.01	General-purpose input 1	-	RO	A	± 1000	
07.02	General-purpose input 2	-	RO	A	± 1000	
07.03	General-purpose input 3	-	RO	A	± 1000	
07.04	General-purpose input 4	-	RO	A	± 1000	
07.05	Speed reference input	-	RO	A	± 1000	
07.06	RMS input voltage	-	RO	A	0 to 1000	
07.07	Stack temperature	-	RO	A	0 to 1000	
07.08	DAC 1 source	1	R/W	A	0 to 1999	+201
07.09	DAC 2 source	1	R/W	A	0 to 1999	+302
07.10	DAC 3 source	1	R/W	A	0 to 1999	+304

Niveau 2

Parameter	Description	Acces level	Type RO / R/W	Variable A/L	Range	Default
07.11	GP1 destination	2	R/W	A	0 to 1999	+318
07.12	GP2 destination	2	R/W	A	0 to 1999	+119
07.13	GP3 destination	2	R/W	A	0 to 1999	+120
07.14	GP4 destination	2	R/W	A	0 to 1999	+408
07.15	Speed destination	2	R/W	A	0 to 1999	+117
07.16	GP1 scaling	2	R/W	A	0 to 1999	1000
07.17	GP2 scaling	2	R/W	A	0 to 1999	1000
07.18	GP3 scaling	2	R/W	A	0 to 1999	1000
07.19	GP4 scaling	2	R/W	A	0 to 1999	+1000
07.20	Speed reference scaling	2	R/W	A	0 to 1999	+1000
07.21	DAC 1 scaling	2	R/W	A	0 to 1999	+1000
07.22	DAC 2 scaling	2	R/W	A	0 to 1999	+1000
07.23	DAC 3 scaling	2	R/W	A	0 to 1999	+1000
07.24	Reference-encoder scaling	2	R/W	A	0 to 1999	419
07.25	Encoder reference selector	2	R/W	L	0 or 1	0
07.26	Current input selector	2	R/W	L	0 or 1	0
07.27	Current sense inverter	2	R/W	L	0 or 1	0
07.28	4mA offset selector	2	R/W	L	0 or 1	1

Three-phase controllers

DMV 2322 / DMV 2342

3.3.7.2 - Menu 07 parameters description

- ◇ RO (Read Only)
- R/W (Read/Write)

◇ 07.01 : General purpose input 1

Range : ± 1000 .

Displays the value of the analogue signal applied to terminal TB1-04. Can be used as a general-purpose input for monitoring, or for processor 2 special applications.

◇ 07.02 : General purpose input 2

Range : ± 1000 .

Displays the value of the analogue signal applied to terminal TB1-05. Can be used as a general-purpose input for monitoring, or for processor 2 special applications.

◇ 07.03 : General purpose input 3

Range : ± 1000 .

Displays the value of the analogue signal applied to terminal TB1-06. Can be used as a general-purpose input for monitoring, or for processor 2 special applications.

◇ 07.04 : General purpose input 4

Range : ± 1000 .

Displays the value of the analogue signal applied to terminal TB1-07. Can be used as a general-purpose input for monitoring, or for processor 2 special applications.

◇ 07.05 : Speed reference input

Range : ± 1000 .

Displays the value of the analogue speed demand at terminal TB1-03, or master encoder reference via PL4, and after scaling by 07.24 ; dependent on reference mode being selected by 07.25.

◇ 07.06 : RMS input voltage

Range : 0 to 1000.

Monitors the value of the voltage applied to line input terminals L1, L2, L3 (the thyristor stack supply).

◇ 07.07 : Stack temperature

Range : 0 to 1000.

Monitors the temperature of the thyristor stack on those drives fitted with thermistors.

□ 07.08 : DAC 1 source

Range : 0 to 1999.

Default : 201.

Selects the source of analogue output 1 via terminal TB2-12.

Default value 201 = 02.01, ramp output.

□ 07.09 : DAC 2 source

Range : 0 to 1999.

Default : 302.

Selects the source of analogue output 2 via terminal TB2-13.

Default value 302 = 03.02, speed feedback.

□ 07.10 : DAC 3 source

Range : 0 to 1999.

Default : 304.

Selects the source of analogue output 3 via terminal TB2-14.

Default value 304 = 03.04, armature voltage.

Note : Of the following "invisible" parameters.

Scaling parameters have a multiplying range from 0.000 to 1.999. Source and destination parameters define a parameter to be used as either input or output, thereby defining the function of the programmable input and output terminals.

□ 07.11 : GP1 destination

Range : 0 to 1999.

Default : 318.

Selects the destination of analogue input 1 via terminal TB1-04.

Default value 318 = 03.18, hard speed reference.

A changed value becomes effective only when the RESET pushbutton is pressed.

□ 07.12 : GP2 destination

Range : 0 to 1999.

Default : 119.

Selects the destination of analogue input 2 via terminal TB1-05.

Default value 119 = 01.19, speed reference 3.

A changed value becomes effective only when the RESET pushbutton is pressed.

□ 07.13 : GP3 destination

Range : 0 to 1999.

Default : 120.

Selects the destination of analogue input 3 via terminal TB1-06.

Default value 120 = 01.20, speed reference 4.

A changed value becomes effective only when the RESET pushbutton is pressed.

□ 07.14 : GP4 destination

Range : 0 to 1999.

Default : 408.

Selects the destination of analogue input 4 via terminal TB1-07.

Default value 408 = 04.08, torque reference.

A changed value becomes effective only when the RESET pushbutton is pressed.

□ 07.15 : Speed reference destination

Range : 0 to 1999.

Default : 117.

Selects the destination of speed reference 07.05. Default value 117 = 01.17, speed reference 1.

A changed value becomes effective only when the RESET pushbutton is pressed.

Three-phase controllers

DMV 2322 / DMV 2342

07.16 : GP1 scaling

Range : 0 to 1999.

Default : +1000.

Sets the scaling for the signal from source GP1 via terminal TB1-04.

Scaling factor $\frac{07.16}{1000}$

07.17 : GP2 scaling

Range : 0 to 1999.

Default : + 1000.

Sets the scaling for the signal from source GP2 via terminal TB1-05.

Scaling factor $\frac{07.17}{1000}$

07.18 : GP3 scaling

Range : 0 to 1999.

Default : +1000.

Sets the scaling for the signal from source GP3 via terminal TB1-06.

Scaling factor $\frac{07.18}{1000}$

07.19 : GP4 scaling

Range : 0 to 1999.

Default : +1000.

Sets the scaling for the signal from source GP4 via terminal TB1-07.

Scaling factor $\frac{07.19}{1000}$

07.20 : Speed reference scaling

Range : 0 to 1999.

Default : +1000.

The factor by which 07.05 is multiplied to produce the speed reference.

Scaling factor $\frac{07.20}{1000}$

07.21 : DAC1 scaling

Range : 0 to 1999.

Default : +1000.

Sets the scaling for signals output from DAC1 TB2-12.

Scaling factor $\frac{07.21}{1000}$

07.22 : DAC2 scaling

Range : 0 to 1999.

Default : +1000.

Sets the scaling for signals output from DAC2 TB2-13.

Scaling factor $\frac{07.22}{1000}$

07.23 : DAC3 scaling

Range : 0 to 1999.

Default : +1000.

Sets the scaling for signals output from DAC3 TB2-14.

Scaling factor $\frac{07.23}{1000}$

07.24 : Reference encoder scaling

Range : 0 to 1999.

Default : +419.

Sets the scaling for signals from the reference encoder connected to terminal socket PL4. The value should be set to correspond with the maximum speed of the motor and with the number of lines-per-revolution of the encoder. To calculate the scale factor.

Scale factor $\frac{1750 \times 10^6}{N \times n}$

Where : N = number of lines-per-revolution (encoder).

n = max speed of motor in rpm.

Default value is determined on the basis of a 1024-line encoder, and a maximum speed of 1750 rpm.

07.25 : Reference encoder selector

Default : 0, analogue reference selected.

1 = encoder selected.

Selects either the analogue signal at terminal TB1-03 or the encoder input via PL4 as the source of speed reference signal.

07.26 : 20 mA current loop selector

Default : 0, voltage input selected.

Configures the speed input terminal (TB1-03) to accept either a voltage or a 20mA input signal.

07.27 : 20mA current loop mode selector 1

Default : 0.

In conjunction with 07.28, configures 20mA current loop input. Refer to table on Logic Diagram H.

07.28 : 20mA current loop mode selector 2 - offset selector

Default : 0.

In conjunction with 07.27, configures 20mA current loop input. Refer to s. 3.4 (Menu 07).

When a 4mA offset is being used, the drive will trip if it senses that the current is < 3.5 mA (indicating " loop open ").

Three-phase controllers

DMV 2322 / DMV 2342

3.3.8 - Menu 08 : Digital inputs

3.3.8.1 - List of parameter Menu 08

RO = Read Only.

R/W = Read/Write.

A = Analog.

L = Logic.

Level 1

Parameter	Description	Acces level	Type RO / R/W	Variable A/L	Range	Default
08.01	F1 input - run permit	-	RO	L	0 or 1	
08.02	F2 input - inch reverse	-	RO	L	0 or 1	
08.03	F3 input - inch forward	-	RO	L	0 or 1	
08.04	F4 input - run reverse	-	RO	L	0 or 1	
08.05	F5 input - run forward	-	RO	L	0 or 1	
08.06	F6 input	-	RO	L	0 or 1	
08.07	F7 input	-	RO	L	0 or 1	
08.08	F8 input	-	RO	L	0 or 1	
08.09	F9 input	-	RO	L	0 or 1	
08.10	F10 input	-	RO	L	0 or 1	
08.11	Enable input	-	RO	L	0 or 1	

Level 2

Parameter	Description	Acces level	Type RO / R/W	Variable A/L	Range	Default
08.12	F2 destination	2	R/W	A	0 to 1999	+ 000
08.13	F3 destination	2	R/W	A	0 to 1999	+ 000
08.14	F4 destination	2	R/W	A	0 to 1999	+ 000
08.15	F5 destination	2	R/W	A	0 to 1999	+ 000
08.16	F6 destination	2	R/W	A	0 to 1999	+ 000
08.17	F7 destination	2	R/W	A	0 to 1999	+ 000
08.18	F8 destination	2	R/W	A	0 to 1999	+ 000
08.19	F9 destination	2	R/W	A	0 to 1999	+ 000
08.20	F10 destination	2	R/W	A	0 to 1999	+ 000
08.21	Disable normal logic functions	2	R/W	L	0 or 1	0
08.22	Invert F2 input	2	R/W	L	0 or 1	0
08.23	Invert F3 input	2	R/W	L	0 or 1	0
08.24	Invert F4 input	2	R/W	L	0 or 1	0
08.25	Invert F5 input	2	R/W	L	0 or 1	0
08.26	Invert F6 input	2	R/W	L	0 or 1	0
08.27	Invert F7 input	2	R/W	L	0 or 1	0
08.28	Invert F8 input	2	R/W	L	0 or 1	0
08.29	Invert F9 input	2	R/W	L	0 or 1	0
08.30	Invert F10 input	2	R/W	L	0 or 1	0

Three-phase controllers

DMV 2322 / DMV 2342

3.3.8.2 - Menu 08 parameters description

- ◇ RO (Read Only)
- R/W (Read/Write)

◇ 08.01 : F1 input - run permit

0 = stop drive.

1 = start enabled.

Monitors the drive start-permit control input from terminal TB3-21 and indicates status. This input performs an over-riding drive stop function in speed control mode as follows.

The input must be active in order that the drive can start. If the input becomes inactive, 08.01 causes the pre-ramp reference 01.03 to be set to zero.

The drive will stop unless 02.03, ramp hold, is active.

◇ 08.02 : F2 input - default inch reverse

0 = input not active.

1 = input active.

Monitors the control input from terminal TB3-22 and indicates status. The drive will respond to this input as inch reverse command only if the external logic controls are enabled (08.21 = 0). Also its function is freely programmable.

◇ 08.03 : F3 input - default inch forward

0 = input not active.

1 = input active.

Monitors the control input from terminal TB3-23 and indicates status. The drive will respond to this input as inch forward command only if the external logic controls are enabled (08.21 = 0). Also its function is freely programmable.

◇ 08.04 : F4 input - default run reverse

0 = input not active.

1 = input active.

Monitors the control input from terminal TB3-24 and indicates status. The drive will respond to this input as run reverse command only if the external logic controls are enabled (08.21 = 0). Also its function is freely programmable.

This is a latched input (parameter 01.11 will not revert to 0 if the input is removed, provided that 08.21 = 0).

◇ 08.05 : F5 input - default run forward

0 = input not active.

1 = input active.

Monitors the control input from terminal TB3-25 and indicates status. The drive will respond to this input as run forward command only if the external logic controls are enabled (08.21 = 0). Also its function is freely programmable.

This is a latched input (parameter 01.11 will not revert to 0 if the input is removed, provided that 08.21 = 0).

◇ 08.06 : F6 input - user-programmable

0 = input not active.

1 = input active.

Monitors the control input from terminal TB3-26 and indicates status.

◇ 08.07 : F7 input - user-programmable

0 = input not active.

1 = input active.

Monitors the control input from terminal TB3-27 and indicates status.

◇ 08.08 : F8 input - user-programmable

0 = input not active.

1 = input active.

Monitors the control input from terminal TB3-28 and indicates status.

◇ 08.09 : F9 input - user-programmable

0 = input not active.

1 = input active.

Monitors the control input from terminal TB3-29 and indicates status.

◇ 08.10 : F10 input - user-programmable

0 = input not active.

1 = input active.

Monitors the control input from terminal TB3-30 and indicates status.

◇ 08.11 : Drive enable input

0 = disable.

1 = enable.

Monitors the drive enable input from terminal TB4-31 and indicates status. Input must be active for the drive to operate. When the drive is disabled by disconnecting the input, all firing pulses are switched off after a 30s delay. If the drive is running when this occurs, the result is a coast-stop and ramps reset.

□ 08.12 : F2 destination

Range : 0 to 1999.

Default : +000.

Defines the destination of external logic input at terminal TB3-22. Effective only after RESET.

□ 08.13 : F3 destination

Range : 0 to 1999.

Default : +000.

Defines the destination of external logic input at terminal TB3-23.

Effective only after RESET.

□ 08.14 : F4 destination

Range : 0 to 1999.

Default : +000.

Defines the destination of external logic input at terminal TB3-24.

Effective only after RESET.

□ 08.15 : F5 destination

Range : 0 to 1999.

Default : +000.

Defines the destination of external logic input at terminal TB3-25.

Effective only after RESET.

□ 08.16 : F6 destination

Range : 0 to 1999.

Default : +000.

Defines the destination of external logic input at terminal TB3-26.

Effective only after RESET.

□ 08.17 : F7 destination

Range : 0 to 1999.

Default : +000.

Defines the destination of external logic input at terminal TB3-27.

Effective only after RESET.

Three-phase controllers

DMV 2322 / DMV 2342

08.18 : F8 destination

Range : 0 to 1999.

Default : +000.

Defines the destination of external logic input at terminal TB3-28.

Effective only after RESET.

08.19 : F9 destination

Range : 0 to 1999.

Default : +000.

Defines the destination of external logic input at terminal TB3-29.

Effective only after RESET.

08.20 : F10 destination

Range : 0 to 1999.

Default : +000.

Defines the destination of external logic input at terminal TB3-30.

Effective only after RESET.

08.21 : Disable normal logic functions

0 = enable normal logic function.

1 = disable normal logic function.

Default : 0.

If set to enable (= 0), this parameter configures logic inputs in the following manner.

F2 : TB3-22 inch reverse,

F3 : TB3-23 inch forward,

F4 : TB3-24 run reverse,

F5 : TB3-25 run forward.

If set to disable (= 1), the logic inputs must be programmed by the user.

If 08.21 = 0, F2/3/4/5 still perform their programmed functions.

08.22 to 08.30 : Logic inversion

Parameters 08.22 to 08.30 inclusive invert the logic of programmable input functions F2 to F10 inclusive.

0 = not invert (default).

1 = invert.

Three-phase controllers

DMV 2322 / DMV 2342

3.3.9 - Menu 09 : Status output

Status output parameters define a parameter to be used as a source, thereby defining the function of programmable output terminals.

Menu 09 contains three status source groupings, and each is invertible. The two sources ST1 and ST2 can be combined in any convenient configuration for output to terminals TB2-15 and TB2-16. The second group selects from sources ST3, ST4, ST5 for output to TB2-17, TB2-18, TB2-19 respectively, or source ST6 (relay output).

Delays 09.12 and 09.18 status outputs ST1 and ST2 in 0 --> 1 transitions. In 1 --> 0 transitions the effect is immediate, without delay.

3.3.9.1 - List of parameters Menu 09

RO = Read Only.

R/W = Read/Write.

A = Analog.

L = Logic.

Level 1

Parameter	Description	Acces level	Type RO / R/W	Variable A/L	Range	Default
09.01	Status 1 output	-	RO	L	0 or 1	
09.02	Status 2 output	-	RO	L	0 or 1	
09.03	Status 3 output	-	RO	L	0 or 1	
09.04	Status 4 output	-	RO	L	0 or 1	
09.05	Status 5 output	-	RO	L	0 or 1	
09.06	Status 6 output (relay)	-	RO	L	0 or 1	

Level 2

Parameter	Description	Acces level	Type RO / R/W	Variable A/L	Range	Default
09.07	Status 1 source 1	2	R/W	A	0 to 1999	+111
09.08	Invert status 1 source 1	2	R/W	L	0 or 1	0
09.09	Status 1 source 2	2	R/W	A	0 to 1999	000
09.10	Invert status 1 source 2	2	R/W	L	0 or 1	0
09.11	Invert status 1 output	2	R/W	L	0 or 1	0
09.12	Status 1 delay	2	R/W	A	0 to 255 s	0
09.13	Status 2 source 1	2	R/W	A	0 to 1999	+1007
09.14	Invert status 2 source 2	2	R/W	L	0 to 1	0
09.15	Status 2 source 2	2	R/W	A	0 to 1999	000
09.16	Invert status 2 source 2	2	R/W	L	0 or 1	0
09.17	Invert status 2 output	2	R/W	L	0 or 1	0
09.18	Status 2 delay	2	R/W	A	0 to 255 s	0
09.19	Status 3 source	2	R/W	A	0 to 1999	+1013
09.20	Invert status 3 output	2	R/W	L	0 or 1	0
09.21	Status 4 source	2	R/W	A	0 to 1999	+1003
09.22	Invert status 4 output	2	R/W	L	0 or 1	0
09.23	Status 5 source	2	R/W	A	0 to 1999	+1006
09.24	Invert status 5 output	2	R/W	L	0 or 1	0
09.25	Status 6 source (relay)	2	R/W	A	0 to 1999	+1009
09.26	Invert status 6 output	2	R/W	L	0 or 1	0

Three-phase controllers

DMV 2322 / DMV 2342

3.3.10 - Menu 10 : Status logic & diagnostic information

All real (not bit) RO parameters are frozen at the instant of tripping as an aid to diagnosis of the fault. They remain in this condition until the drive is reset.

3.3.10.1 - List of parameters Menu 10

RO = Read Only.

R/W = Read/Write.

A = Analog.

L = Logic.

Level 0 et 1

Parameter	Description	Acces level	Type RO / R/W	Variable A/L	Range	Default
10.01	Forward velocity	-	RO	L	0 or 1	
10.02	Reverse velocity	-	RO	L	0 or 1	
10.03	Current limit	-	RO	L	0 or 1	
10.04	Bridge 1 enabled	-	RO	L	0 or 1	
10.05	Bridge 2 enabled	-	RO	L	0 or 1	
10.06	Electrical phase-back	-	RO	L	0 or 1	
10.07	At speed	-	RO	L	0 or 1	
10.08	Overspeed	-	RO	L	0 or 1	
10.09	Zero speed	-	RO	L	0 or 1	
10.10	Armature voltage clamp active	-	RO	L	0 or 1	
10.11	Phase rotation	-	RO	L	0 or 1	
10.12	Drive healthy	-	RO	L	0 or 1	
10.13	Alarm l x t	-	RO	L	0 or 1	
10.14	Field loss	-	RO	L	0 or 1	
10.15	Feedback loss	-	RO	L	0 or 1	
10.16	Phase loss	-	RO	L	0 or 1	
10.17	Instantaneous trip	-	RO	L	0 or 1	
10.18	Sustained overload	-	RO	L	0 or 1	
10.19	Processor 1 watchdog	-	RO	L	0 or 1	
10.20	Processor 2 watchdog	-	RO	L	0 or 1	
10.21	Motor overtemperature	-	RO	L	0 or 1	
10.22	Stack overtemperature	-	RO	L	0 or 1	
10.23	Speed loop saturated	-	RO	L	0 or 1	
10.24	Zero current limit	-	RO	L	0 or 1	
10.25	Last trip	-	RO	A	0 to 255	
10.26	The trip before last trip (10.25)	-	RO	A	0 to 255	
10.27	The trip before 10.26	-	RO	A	0 to 255	
10.28	The trip before 10.27	-	RO	A	0 to 255	

Level 2

Parameter	Description	Acces level	Type RO / R/W	Variable A/L	Range	Default
10.29	Disable field loss	2	R/W	L	0 or 1	0
10.30	Disable feedback loss	2	R/W	L	0 or 1	0
10.31	Disable phase loss	2	R/W	L	0 or 1	0
10.32	Disable motor 0'temperature trip	2	R/W	L	0 or 1	1
10.33	Disable stack 0'temperature trip	2	R/W	L	0 or 1	1
10.34	External trip	2	R/W	L	0 or 1	0
10.35	Processor 2 trip	2	R/W	A	0 to 255	0

Three-phase controllers

DMV 2322 / DMV 2342

3.3.10.2 - Menu 10 parameters description

- ◇ RO (Read Only)
- R/W (Read/Write)

◇ 10.01 : Forward velocity

0 : drive stationary or running in reverse.
1 : drive running forward at > zero speed threshold.

Forward direction defined as :

- when tacho feedback selected, terminal TB1-09 negative with respect to terminal TB1-10,
- when armature voltage feedback selected, terminal A1 positive with respect to terminal A2,
- when encoder feedback selected, A-channel leads B-channel.

◇ 10.02 : Reverse velocity

0 : drive stationary or running forward.
1 : drive running in reverse at > zero speed threshold.

Reverse direction defined as follows :

- when tacho feedback selected, terminal TB1-09 positive with respect to terminal TB1-10,
- when armature voltage feedback selected, terminal A1 negative with respect to terminal A2,
- when encoder feedback selected, A-channel lags B-channel.

Note : If 10.01 = 10.02 = 0, the motor is either stationary or running at < zero speed threshold. In this condition, 10.09 = 1 and the zero speed LED illuminates on the keypad (and RL2 is energised, if programmed to indicate zero speed).

◇ 10.03 : Current limit

0 : drive not in current limit.
1 : drive in current limit.

Indicates that the sum of the current demand 04.01 and the offset 04.09 is being limited by the current limit override 04.03 or by one of the bridge limits.

◇ 10.04 : Bridge 1 enabled

0 : disabled.
1 : enabled.

Indicates that thyristor bridge 1 (the forward or positive bridge) is being fired. Does not necessarily indicate that the bridge is conducting, since conduction depends on firing angle and operating conditions.

◇ 10.05 : Bridge 2 enabled

0 : disabled.
1 : enabled.

Indicates that thyristor bridge 2 (the reverse or negative bridge) is being fired. Does not necessarily indicate that the bridge is conducting, since conduction depends on firing angle and operating conditions.

◇ 10.06 : Electrical phase-back

0 : firing pulses not phased back.
1 : firing pulses phased back (at standstill).

Indicates that the firing pulses are being phased back by the action of the standstill function. Refer to 05.18 and 05.19.

◇ 10.07 : At speed

0 : drive not at speed.
1 : drive at speed.

Indicates that the drive has attained set speed, post-ramp reference 02.01 = pre-ramp reference 01.03, and also that comparison of final speed demand 03.01 with speed feedback 03.02 results in a speed error of < 1.5 % of maximum speed. External signal also provided through open collector output ST2 to terminal TB2-16 if source parameter 09.13 is at default setting.

◇ 10.08 : Overspeed

0 : motor not overspeeding.
1 : motor over speed.

Indicates that the speed feedback 03.02 > ± 1000, that is, the speed is out of range, suggesting that the motor is being mechanically driven faster than the maximum speed of the drive. This function is a monitor only, and does not initiate a trip signal.

◇ 10.09 : Zero speed

0 : speed not zero.
1 : zero speed.

Set if speed feedback 03.02 < zero speed threshold 03.23. Refer to 10.01 and 10.02.

◇ 10.10 : Armature voltage clamp active

0 : clamp not active.
1 : clamp active.

Set when the armature voltage clamp is activated. Prevents the voltage from increasing further. Refer to 03.15.

◇ 10.11 : Phase rotation

0 : L1 L3 L2.
1 : L1 L2 L3.

Rotation is detected from L1, L2, L3. Note that connection to E1 and E3 must also be correct. Refer to s. 2.1.1 c.

◇ 10.12 : Drive healthy

1 : drive is powered-up and has not tripped.

◇ 10.13 : Alarm

0 : no alarm condition present.
1 : alarm condition present, impending sustained-overload trip.

Indicates that the drive is in an overload condition and will eventually trip on sustained overload 10.18 if the overload condition is not removed. The time taken to trip is dependent on the settings of 05.06 and 05.07 and on the magnitude of overload.

Visual indication that the alarm has been actuated is given by the alarm LED (flashing). External signal also provided through status logic output ST3 to terminal TB2-17, provided that source parameter 09.19 is at its default value.

Three-phase controllers

DMV 2322 / DMV 2342

◇ 10.14 : Field loss

0 : field healthy.
1 : field failed.

Indicates that no current is being drawn from the internal field supply (or the EXC - DMV optional external field control module if installed).

◇ 10.15 : Feedback loss

0 : speed feedback present.
1 : speed feedback absent or polarity reversed.

Indicates no feedback signal, or reversed polarity. Applies equally to tachogenerator and encoder feedback, whichever is selected. Loss of feedback is not detected until the firing angle has advanced to the point where the value of 05.03 (firing angle) > 767. This condition can be prevented from tripping the drive by disabling feedback loss detection 10.30.

◇ 10.16 : Supply or phase loss

0 : healthy.
1 : supply/phase loss.

Indicates loss of one or more input phases connected to L1, L2, L3. Can be disabled by means of 10.31.

◇ 10.17 : Instantaneous trip

0 : no overcurrent peak detected.
1 : overcurrent peak detected.

Indicates that a current peak > 2 x (max. current according to the burden resistor fitted) has occurred. The result is that firing pulses are immediately suppressed, shutting the drive down.

◇ 10.18 : Sustained overload

0 : sustained overload not detected.
1 : sustained overload detected.

Indicates that current feedback 05.01 has exceeded the overload threshold 05.06 for a length of time determined by the overload time values 05.07 and 05.08 integrated with the magnitude of the overload (the conventional I x t function).

When the current exceeds the overload threshold, the excess integrates with time causing the value of the actual overload 05.11 to increase.

Conversely, if the current falls below the threshold during integration, the value of 05.11 falls towards zero. The rate of integration is set by 05.07 when the current is > threshold, and by 05.08 when the current is < threshold. The rate of integration is the trip time with full scale overload (05.01 = 1000). This function imitates the behaviour of a thermal relay and simulates the thermal characteristic of a motor.

◇ 10.19 : Processor 1 watchdog

0 : healthy.
1 : trip.

In normal operation of the drive the watchdog timer is reset periodically by processor 1 as a check that the processor and drive programme are functioning normally. If a reset does not occur before the timer has timed out the conclusion is either that the processor has failed or that the drive programme has crashed.

The result is immediate controlled shutdown of the drive, accompanied by a watchdog fault trip signal.

◇ 10.20 : Processor 2 watchdog

0 : healthy.
1 : trip.

◇ 10.21 : Motor overtemperature

0 : healthy.
1 : trip.
10.21 = 1 indicates trip detected at the motor thermistor input terminal.
Trip lever : 3 k Ω ,
Detector reset level : 1.8 k Ω .

◇ 10.22 : Stack overtemperature

0 : healthy.
1 : trip.
10.22 = 1 indicates thyristor stack overtemperature, >100 °C (on drives fitted with a thyristor stack thermistor).

◇ 10.23 : Speed loop saturated

0 : speed loop not saturated.
1 : speed loop saturated.
Indicates that the output of the speed loop algorithm, from which the current demand 04.01 is derived, is at a limit. This may be due to the application of a current limit or a zero-current clamp, and may occur if the motor is mechanically stalled.

◇ 10.24 : Zero current demand

0 : current demand > 0.
1 : current demand = 0.
Indicates that the current demand signal is being limited to zero. This could occur, for example, as a result of a sudden loss of load, the drive being in torque control mode with speed over-ride. The speed could reach the set speed threshold as a consequence, causing the speed loop to reduce the current demand to zero.

◇ 10.25 : Last trip

Range : 0 to 255.
Record of the last-trip code, forming the basis of a trip history.

◇ 10.26 : The trip before the last trip (10.25)

Range : 0 to 255.
Record of the trip before that which is saved in 10.25.

◇ 10.27 : The trip before 10.26

Range : 0 to 255.
Record of the trip before that which is saved in 10.26.

◇ 10.28 : The trip before 10.27

Range : 0 to 255.
Record of the trip before that which is saved in 10.27. The four parameters 10.25 to 10.28 provide a permanent memory of the last four trips. They are updated only by a new trip occurring.

Three-phase controllers

DMV 2322 / DMV 2342

10.29 : Disable field loss trip

Default : 0, field loss trip enabled.

Prevents the drive from tripping when field loss is detected, for example, in applications where the internal field supply is not used or is switched off when the drive is not running.

10.30 : Disable feedback loss trip

Default : 0, feedback loss enabled.

Prevents the drive from tripping when speed feedback loss is detected, for example in certain load-sharing applications and in applications which do not involve motors, such as battery charging and other electrolytic processes.

10.31 : Disable supply or phase loss trip

Default : 0, supply/phase loss enabled.

Prevents the drive from tripping when supply or supply phase loss is detected, allowing the drive to ride through brief supply interruptions.

10.32 : Disable motor overtemperature trip

Default : 1, motor overtemperature trip disabled.

Prevents the drive from tripping when motor temperature sensor input changes to high resistance, for example when motor overtemperature protection is used in the alarm mode, or to achieve a line normal stop.

10.33 : Disable stack overtemperature trip

Default : 1, stack overtemperature trip disabled.

Prevents the drive from tripping when stack temperature sensor detects a temperature greater than 100°C, for example when stack overtemperature protection is used in the alarm mode, or to achieve a system normal stop.

10.34 : External trip

Default : 0.

If 10.34 = 1, the drive will trip. If an external trip is required, the user can programme any logic input to control this bit (refer to Menu 08). Alternatively it can be controlled by application software or through the serial interface.

10.35 : Processor 2 trip

Range : 0 to 255.

If the drive is healthy, the data display for 10.35 is 0. The value of 10.35 is continuously monitored by the processor and the drive tripped immediately if a non-zero value (other than 255) appears via the serial communications interface, or processor 2 software.

If 10.35 = 255, this is the equivalent of a RESET.

Three-phase controllers

DMV 2322 / DMV 2342

3.3.11 - Menu 11 : Miscellaneous

User-defined menu

Parameters 11.01 through to 11.10 define the parameters in the user-defined Menu 00. For example, if the user wishes parameter 00.01 to display speed in rpm (03.03), parameter 11.01 (corresponding to 00.01) should be set to 303.

3.3.11.1 - List of parameters Menu 11

RO = Read Only.

R/W = Read/Write.

A = Analog.

L = Logic.

Level 0 et 1

Parameter	Description	Acces level	Type RO / R/W	Variable A/L	Range	Default
11.01	Parameter 00.01	0	R/W	A	0 to 1999	0
11.02	Parameter 00.02	0	R/W	A	0 to 1999	0
11.03	Parameter 00.03	0	R/W	A	0 to 1999	0
11.04	Parameter 00.04	0	R/W	A	0 to 1999	0
11.05	Parameter 00.05	0	R/W	A	0 to 1999	0
11.06	Parameter 00.06	0	R/W	A	0 to 1999	0
11.07	Parameter 00.07	0	R/W	A	0 to 1999	0
11.08	Parameter 00.08	0	R/W	A	0 to 1999	0
11.09	Parameter 00.09	0	R/W	A	0 to 1999	0
11.10	Parameter 00.10	0	R/W	A	0 to 1999	0
11.11	Serial address	1	R/W	A	0 to 99	001
11.12	Baud rate	1	R/W	L	0 to 1	0
11.13	Serial mode	1	R/W	A	0 to 3	001
11.14	Country code	1	R/W	A	0 to 255	044
11.15	Processor 1 version	-	RO	A	0 to 255	
11.16	Processor 2 version	-	RO	A	0 to 255	

Level 2

Parameter	Description	Acces level	Type RO / R/W	Variable A/L	Range	Default
11.17	Security code 3	2	R/W	A	0 to 255	149
11.18	Reserved		R/W		0 to 1999	+000
11.19	Serial programmable source	2	R/W	A	0 to 1999	+ 000
11.20	Serial scaling	2	R/W	A	0 to 1999	+ 1000
11.21	LEDs byte	2	R/W	A	0 to 255	
11.22	Disable normal LED functions	2	R/W	L	0 or 1	0
11.23	Reserved		R/W		0 or 1	0

Three-phase controllers

DMV 2322 / DMV 2342

3.3.11.2 - Menu 11 parameters description

- ◇ RO (Read Only)
- R/W (Read/Write)

□ 11.11 : Serial address

Range : 0 to 99.

Default : 001.

Defines the unique address of a drive when several are connected to common serial bus in a multidrop application. If set ≥ 100 , the value is taken as 99.

□ 11.12 : Baud rate

Range : 0 to 1.

Default : 0.

Two Baud rates are available for the communications interface with the standard drives. Enter the " setting " number appropriate to the required Baud rate as shown.

Setting : 0 = 4800 Baud.

Setting : 1 = 9600 Baud.

□ 11.13 : Serial mode

Range : 1 to 3.

Default : 001.

Defines the mode of operation of the serial port. There are three modes. Enter the " setting " number appropriate to the required mode as shown.

Mode	Setting
ANSI protocol	1
Output variable defined by 11.19	2
Input variable into parameter defined by 11.19	3

Mode 1 is for communication between the drive and another serial device (terminal, plc, computer). Mode settings 2 and 3 are for rapid transfer of information between two drives, avoiding the need for analogue signals to pass between them. For example, mode settings 2 and 3 could be used in a load-sharing application to output the current demand from one drive in Mode 2 and input a current demand to another in Mode 3. Refer also to 11.19 and 11.20.

□ 11.14 : Country code

Range : 0 to 255.

Default : 044.

(User only with optional control pod to display drive information in appropriate language).

◇ 11.15 : Processor 1 software version

Range : 0 to 255.

Displays the revision number of the software installed in processor 1. For example, version 1.0.0 is displayed as 10 (data window).

◇ 11.16 : Processor 2 software version

Range : 0 to 255.

Reserved for processor 2 special application software (CAP - DMV option pcb).

□ 11.17 : Level 3 security code

Range : 0 to 255.

Default : 149.

If this parameter is changed (to any value other than 0 or 149) and stored, the value set must be entered into parameter 0 to return the drive to its " as-delivered " state. Level 1 or level 2 security must then be used in the normal way. If 11.17 is set = 0, all parameters are freely read-write accessible without the need to enter a security code. To store, set parameter 00 = 1 and press RESET.

□ 11.18 : Reserved

Range : 0 to 1999.

Default : +000.

□ 11.19 : Serial programmable source

Range : 0 to 1999.

Default : +000.

Defines an output or input parameter when serial mode 2 or 3 is selected. Refer to 11.13.

□ 11.20 : Serial scaling

Range : 0 to 1999.

Default : +1000.

Scales the input data in serial mode 3. Refer to 11.13.

□ 11.21 : LEDs byte

Range : 0 to 255.

Designations :

- Bit 7 : alarm.
- Bit 6 : zero speed.
- Bit 5 : run forward.
- Bit 4 : run reverse.
- Bit 3 : bridge 1.
- Bit 2 : bridge 2.
- Bit 1 : at speed.
- Bit 0 : current limit.

The displayed value is the decimal equivalent of the bit-pattern.

□ 11.22 : Disable normal LED functions

Default : 0, enabled.

Disables the normal functions of the keypad LED indicators (with the exception of drive ready) and renders them programmable. By setting 11.22 = 1, normal LED functions (with the exception of drive ready) can be controlled via the serial interface or processor 2 special application software. The LEDs display the binary equivalent of the value in 11.21.

□ 11.23 : Reserved

Default : 0.

Three-phase controllers

DMV 2322 / DMV 2342

3.3.12 - Menu 12 : Programmable thresholds

3.3.12.1 - List of parameters Menu 12

RO = Read Only.

R/W = Read/Write.

A = Analog.

L = Logic.

Level 1

Parameter	Description	Acces level	Type RO / R/W	Variable A/L	Range	Default
12.01	Threshold 1 exceeded	-	RO	L	0 or 1	
12.02	Threshold 2 exceeded	-	RO	L	0 or 1	
12.03	Threshold 1 source	1	R/W	A	0 to 1999	+ 302
12.04	Threshold 1 level	1	R/W	A	0 to 1000	+ 000
12.05	Threshold 1 hysteresis	1	R/W	A	0 to 255	002
12.06	Invert threshold 1 output	1	R/W	L	0 or 1	0
12.07	Threshold 1 destination	1	R/W	A	0 to 1999	+ 000
12.08	Threshold 2 source	1	R/W	A	0 to 1999	+ 501
12.09	Threshold 2 level	1	R/W	A	0 to 1000	+ 000
12.10	Threshold 2 hysteresis	1	R/W	A	0 to 255	002
12.11	Invert threshold 2 output	1	R/W	L	0 or 1	0
12.12	Threshold 2 destination	1	R/W	L	0 to 1999	+ 000

3.3.12.2 - Menu 12 parameters description

RO (Read Only)

R/W (Read/Write)

12.01 : Threshold 1 exceeded

0 : healthy.

1 : threshold exceeded.

12.02 : Threshold 2 exceeded

0 : healthy.

1 : threshold exceeded.

12.03 : Threshold 1 source

Range : 0 to 1999.

Default : +302.

12.04 : Threshold 1 level

Range : 0 to 1000.

Default : +000.

12.05 : Threshold 1 hysteresis

Range : 0 to 255.

Default : 002.

12.06 : Invert threshold 1 output

0 : default.

1 : signal inverted.

12.07 : Threshold 1 destination

Range : 0 to 1999.

Default : +000.

12.08 : Threshold 2 source

Range : 0 to 1999.

Default : +501.

12.09 : Threshold 2 level

Range : 0 to 1000.

Default : +000.

12.10 : Threshold 2 hysteresis

Range : 0 to 255.

Default : 002.

12.11 : Invert threshold 2 output

0 : default.

1 : signal inverted.

12.12 : Threshold 2 destination

Range : 0 to 1999.

Default : +000.

Three-phase controllers

DMV 2322 / DMV 2342

3.3.13 - Menu 13 : Digital lock

3.3.13.1 - List of parameters Menu 13

RO = Read Only.

R/W = Read/Write.

A = Analog.

L = Logic.

Level 1

Parameter	Description	Acces level	Type RO / R/W	Variable A/L	Range	Default
13.01	Master counter value	-	RO	A	0 to 1023	
13.02	Slave counter value	-	RO	A	0 to 1023	
13.03	Master counter increment	-	RO	A	± 1000	
13.04	Slave counter increment	-	RO	A	± 1000	
13.05	Position error	-	RO	A	± 1000	
13.06	Precision reference lsb	1	R/W	A	0 to 255	000
13.07	Precision reference msb	1	R/W	A	0 to 255	000
13.08	Position loop gain	1	R/W	A	0 to 255	025
13.09	Position loop correction limit	1	R/W	A	0 to 1000	+ 010
13.10	Enable digital lock	1	R/W	L	0 or 1	0
13.11	Rigid lock selector	1	R/W	L	0 or 1	1
13.12	Precision reference selector	1	R/W	L	0 or 1	0
13.13	Precision reference latch	1	R/W	L	0 or 1	1

3.3.14 - Menu 14 : CAP - DMV system set-up

3.3.14.1 - List of parameters Menu 14

RO = Read Only.

R/W = Read/Write.

A = Analog.

L = Logic.

Level 1

Parameter	Description	Acces level	Type RO / R/W	Variable A/L	Range	Default
14.01	Serial address	1	R/W		0 to 99	001
14.02	Current drive number	1	R/W		0 to 99	001
14.03	Baud rate	1	R/W		0 to 192	48
14.04	Line pacing character	1	R/W		0 to 225	000
14.05	" Basic " autoboot programme	1	R/W		0 to 225	000
14.06	Line feed enable	1	R/W		0 or 1	1
14.07	Prompt enable	1	R/W		0 or 1	1
14.08	Parity enable	1	R/W		0 or 1	0
14.09	Parity type or checksum enable	1	R/W		0 or 1	0
14.10	Enable application programme 0	1	R/W		0 or 1	1
14.11	Enable application programme 1	1	R/W		0 or 1	0
14.12	Enable application programme 2	1	R/W		0 or 1	0
14.13	Enable application programme 3	1	R/W		0 or 1	0
14.14	Enable application programme 4	1	R/W		0 or 1	0
14.15	Enable application programme 5	1	R/W		0 or 1	0
14.16	Enable application programme watchdog	1	R/W		0 or 1	0
14.17	Select APs in user's EPROM	1	R/W		0 or 1	0

Three-phase controllers

DMV 2322 / DMV 2342

3.3.15 - Menu 15 : Applications Menu 1

3.3.15.1 - List of parameters Menu 15

RO = Read Only.

R/W = Read/Write.

A = Analog.

L = Logic.

Level 1

Parameter	Description	Access level	Type RO / R/W	Variable A/L	Range	Default
15.01	RO variable 1	-	RO	A	± 1999	
15.02	RO variable 2	-	RO	A	± 1999	
15.03	RO variable 3	-	RO	A	± 1999	
15.04	RO variable 4	-	RO	A	± 1999	
13.05	RO variable 5	-	RO	A	± 1999	
15.06	Real R/W variable 1	1	R/W	A	± 1999	+ 000
15.07	Real R/W variable 2	1	R/W	A	± 1999	+ 000
15.08	Real R/W variable 3	1	R/W	A	± 1999	+ 000
15.09	Real R/W variable 4	1	R/W	A	± 1999	+ 000
15.10	Real R/W variable 5	1	R/W	A	± 1999	+ 000
15.11	Integer R/W variable 1	1	R/W	A	0 to 225	000
15.12	Integer R/W variable 2	1	R/W	A	0 to 225	000
15.13	Integer R/W variable 3	1	R/W	A	0 to 225	000
15.14	Integer R/W variable 4	1	R/W	A	0 to 225	000
15.15	Integer R/W variable 5	1	R/W	A	0 to 225	000
15.16	Integer R/W variable 6	1	R/W	A	0 to 225	000
15.17	Integer R/W variable 7	1	R/W	A	0 to 225	000
15.18	Integer R/W variable 8	1	R/W	A	0 to 225	000
15.19	Integer R/W variable 9	1	R/W	A	0 to 225	000
15.20	Integer R/W variable 10	1	R/W	A	0 to 225	000
15.21	Bit variable 1	1	R/W	L	0 or 1	0
15.22	Bit variable 2	1	R/W	L	0 or 1	0
15.23	Bit variable 3	1	R/W	L	0 or 1	0
15.24	Bit variable 4	1	R/W	L	0 or 1	0
15.25	Bit variable 5	1	R/W	L	0 or 1	0
15.26	Bit variable 6	1	R/W	L	0 or 1	0
15.27	Bit variable 7	1	R/W	L	0 or 1	0
15.28	Bit variable 8	1	R/W	L	0 or 1	0
15.29	Bit variable 9	1	R/W	L	0 or 1	0
15.30	Bit variable 10	1	R/W	L	0 or 1	0
15.31	Bit variable 11	1	R/W	L	0 or 1	0
15.32	Bit variable 12	1	R/W	L	0 or 1	0
15.33	Bit variable 13	1	R/W	L	0 or 1	0
15.24	Bit variable 14	1	R/W	L	0 or 1	0
15.35	Bit variable 15	1	R/W	L	0 or 1	0
15.36	Bit variable 16	1	R/W	L	0 or 1	0

Three-phase controllers

DMV 2322 / DMV 2342

3.3.16 - Menu 16 : Applications Menu 2

3.3.16.1 - List of parameters Menu 16

RO = Read Only.

R/W = Read/Write.

A = Analog.

L = Logic.

Level 1

Parameter	Description	Access level	Type RO / R/W	Variable A/L	Range	Default
16.01	RO variable 1	-	RO	A	± 1999	
16.02	RO variable 2	-	RO	A	± 1999	
16.03	RO variable 3	-	RO	A	± 1999	
16.04	RO variable 4	-	RO	A	± 1999	
16.05	RO variable 5	-	RO	A	± 1999	
16.06	Real R/W variable 1	1	R/W	A	± 1999	+ 000
16.07	Real R/W variable 2	1	R/W	A	± 1999	+ 000
16.08	Real R/W variable 3	1	R/W	A	± 1999	+ 000
16.09	Real R/W variable 4	1	R/W	A	± 1999	+ 000
16.10	Real R/W variable 5	1	R/W	A	± 1999	+ 000
16.11	Integer R/W variable 1	1	R/W	A	0 to 225	000
16.12	Integer R/W variable 2	1	R/W	A	0 to 225	000
16.13	Integer R/W variable 3	1	R/W	A	0 to 225	000
16.14	Integer R/W variable 4	1	R/W	A	0 to 225	000
16.15	Integer R/W variable 5	1	R/W	A	0 to 225	000
16.16	Integer R/W variable 6	1	R/W	A	0 to 225	000
16.17	Integer R/W variable 7	1	R/W	A	0 to 225	000
16.18	Integer R/W variable 8	1	R/W	A	0 to 225	000
16.19	Integer R/W variable 9	1	R/W	A	0 to 225	000
16.20	Integer R/W variable 10	1	R/W	A	0 to 225	000
16.21	Bit variable 1	1	R/W	L	0 or 1	0
16.22	Bit variable 2	1	R/W	L	0 or 1	0
16.23	Bit variable 3	1	R/W	L	0 or 1	0
16.24	Bit variable 4	1	R/W	L	0 or 1	0
16.25	Bit variable 5	1	R/W	L	0 or 1	0
16.26	Bit variable 6	1	R/W	L	0 or 1	0
16.27	Bit variable 7	1	R/W	L	0 or 1	0
16.28	Bit variable 8	1	R/W	L	0 or 1	0
16.29	Bit variable 9	1	R/W	L	0 or 1	0
16.30	Bit variable 10	1	R/W	L	0 or 1	0
16.31	Bit variable 11	1	R/W	L	0 or 1	0
16.32	Bit variable 12	1	R/W	L	0 or 1	0
16.33	Bit variable 13	1	R/W	L	0 or 1	0
16.24	Bit variable 14	1	R/W	L	0 or 1	0
16.35	Bit variable 15	1	R/W	L	0 or 1	0
16.36	Bit variable 16	1	R/W	L	0 or 1	0

Three-phase controllers DMV 2322 / DMV 2342

3.4 - Drive control logic diagrams System overview

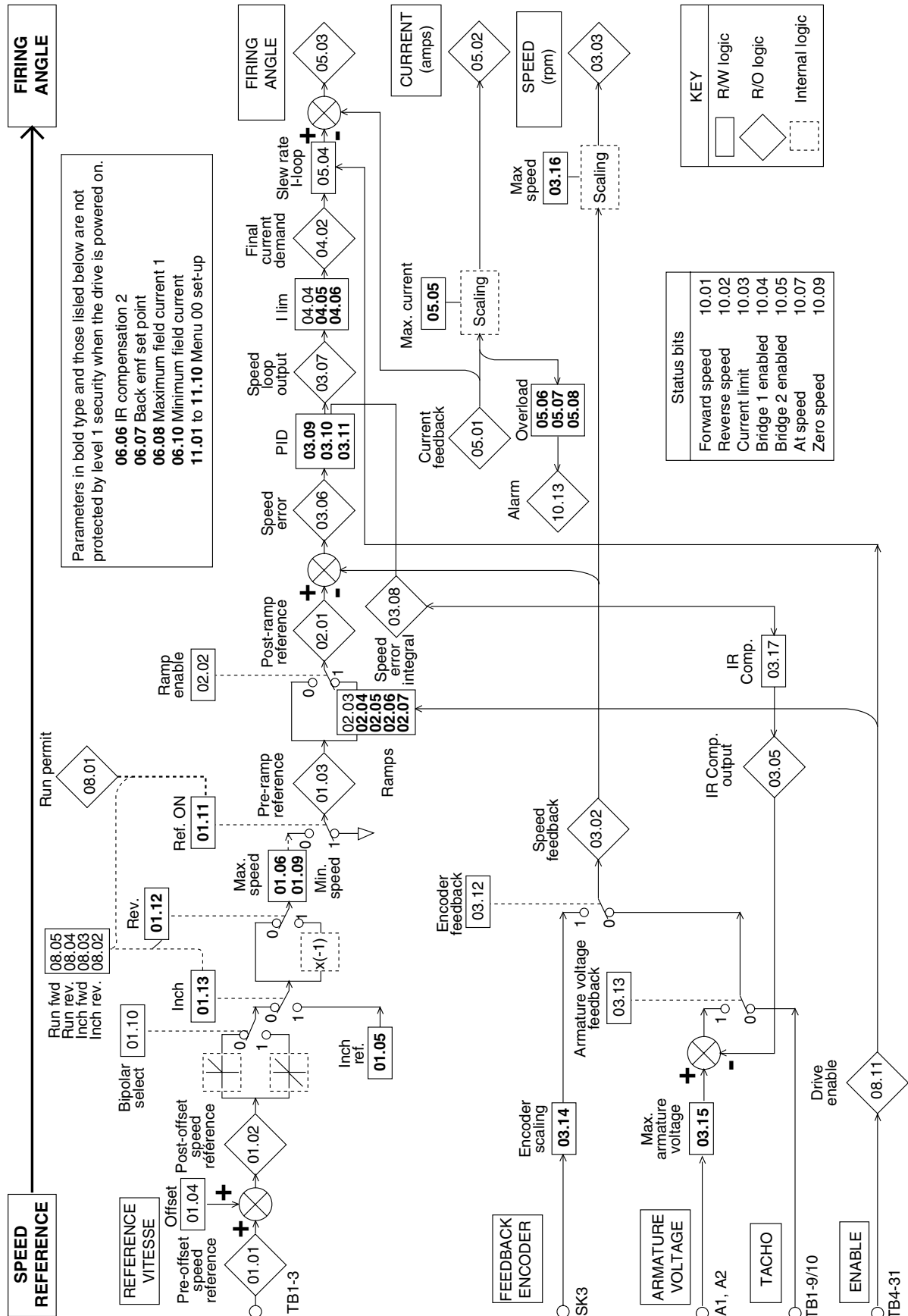

Three-phase controllers DMV 2322 / DMV 2342

3.4.1 - Menu 01 : Speed reference selection & limits

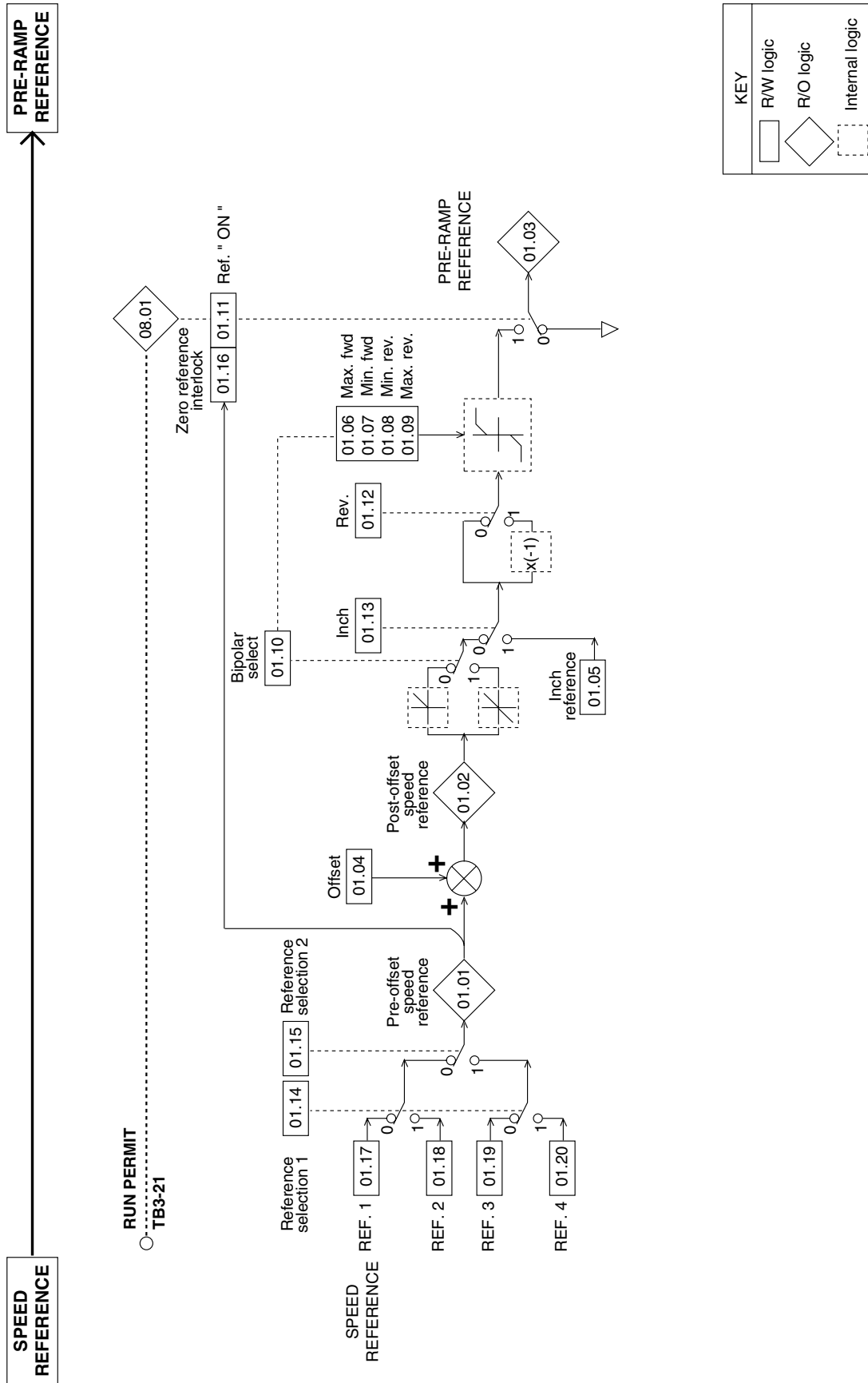

Three-phase controllers DMV 2322 / DMV 2342

3.4.3 - Menu 03 : Feedback selection & speed loop

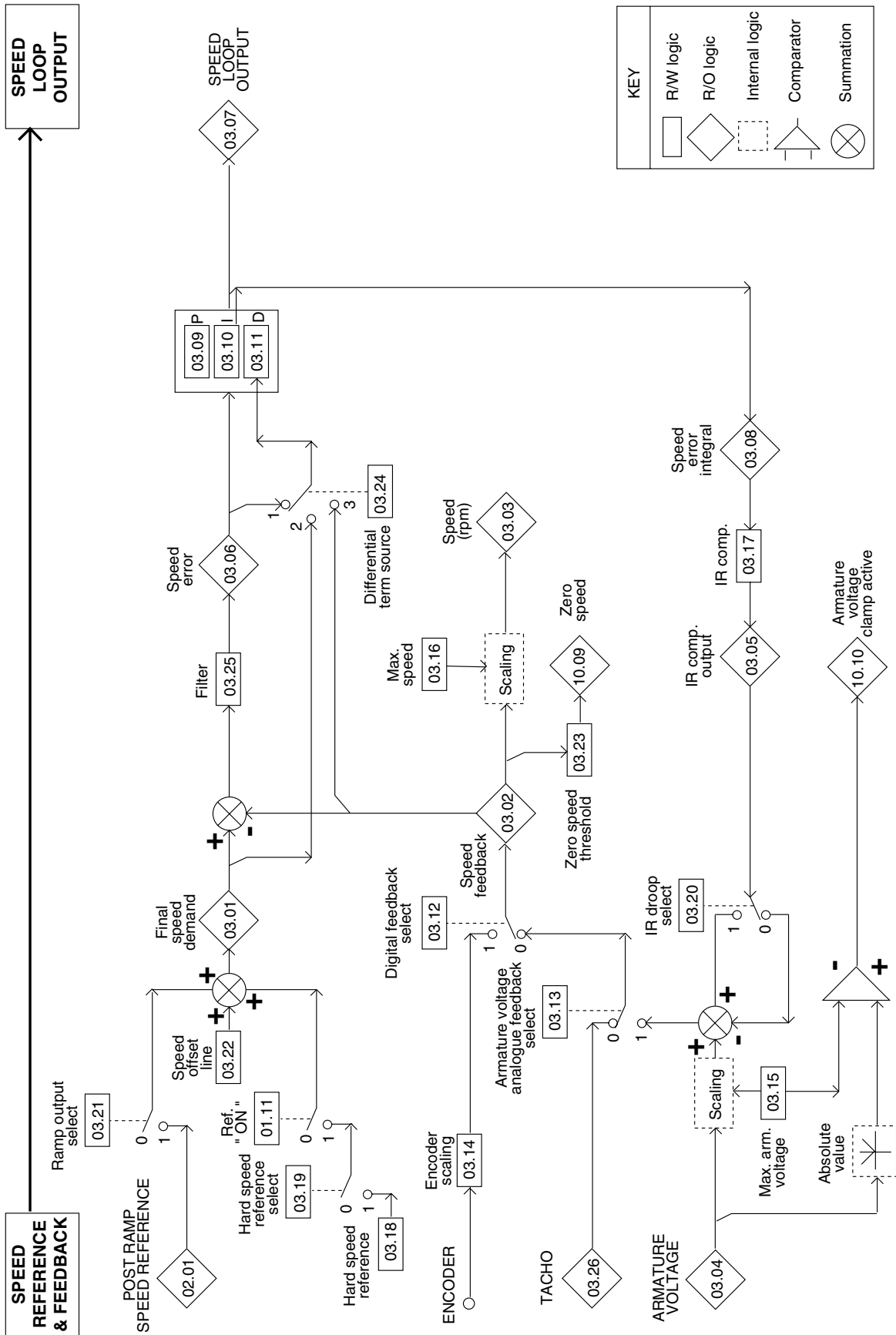

Three-phase controllers DMV 2322 / DMV 2342

3.4.4 - Menu 04 : Current selection & limits

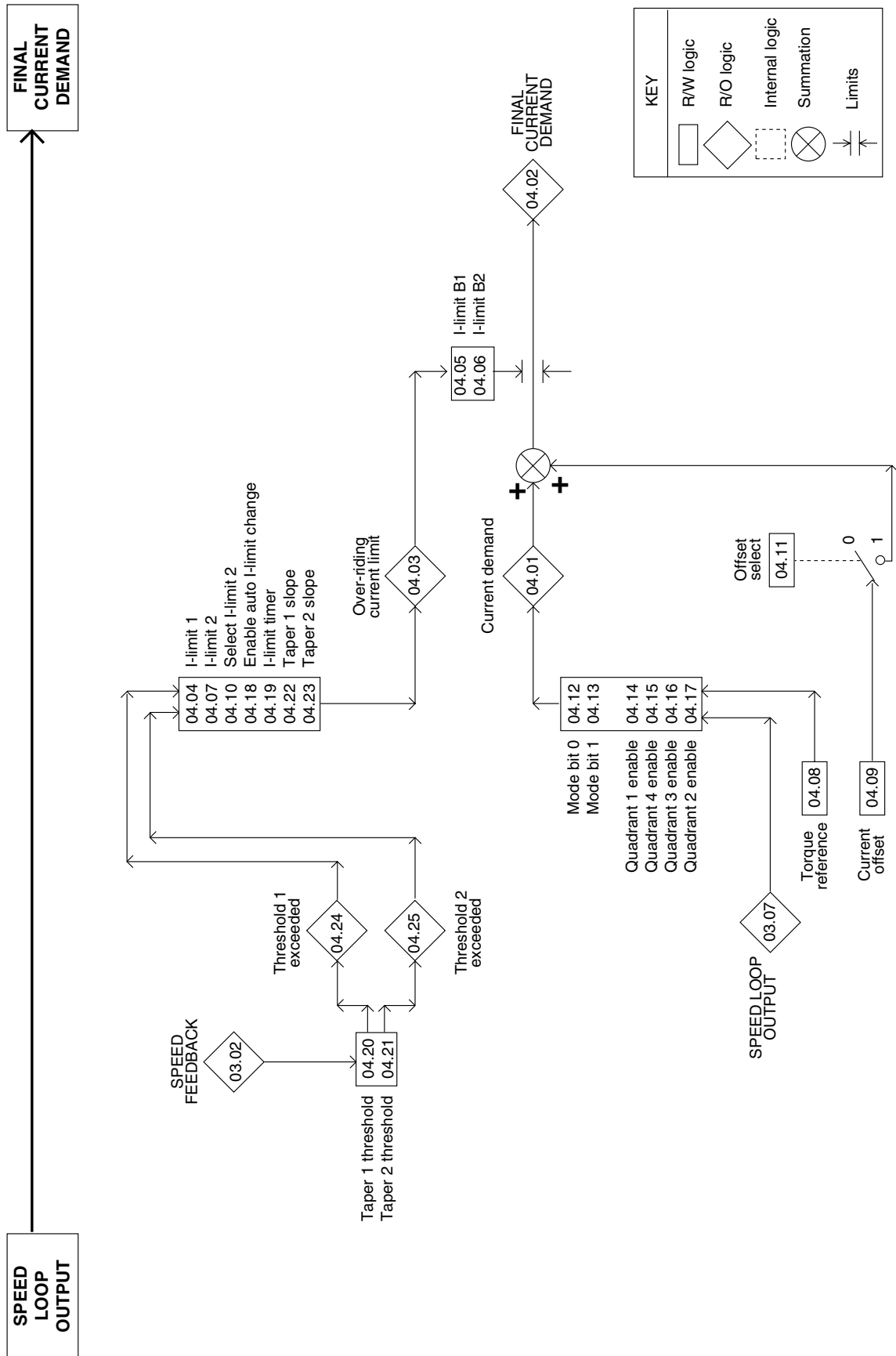

Three-phase controllers DMV 2322 / DMV 2342

3.4.5 - Menu 05 : Current loop

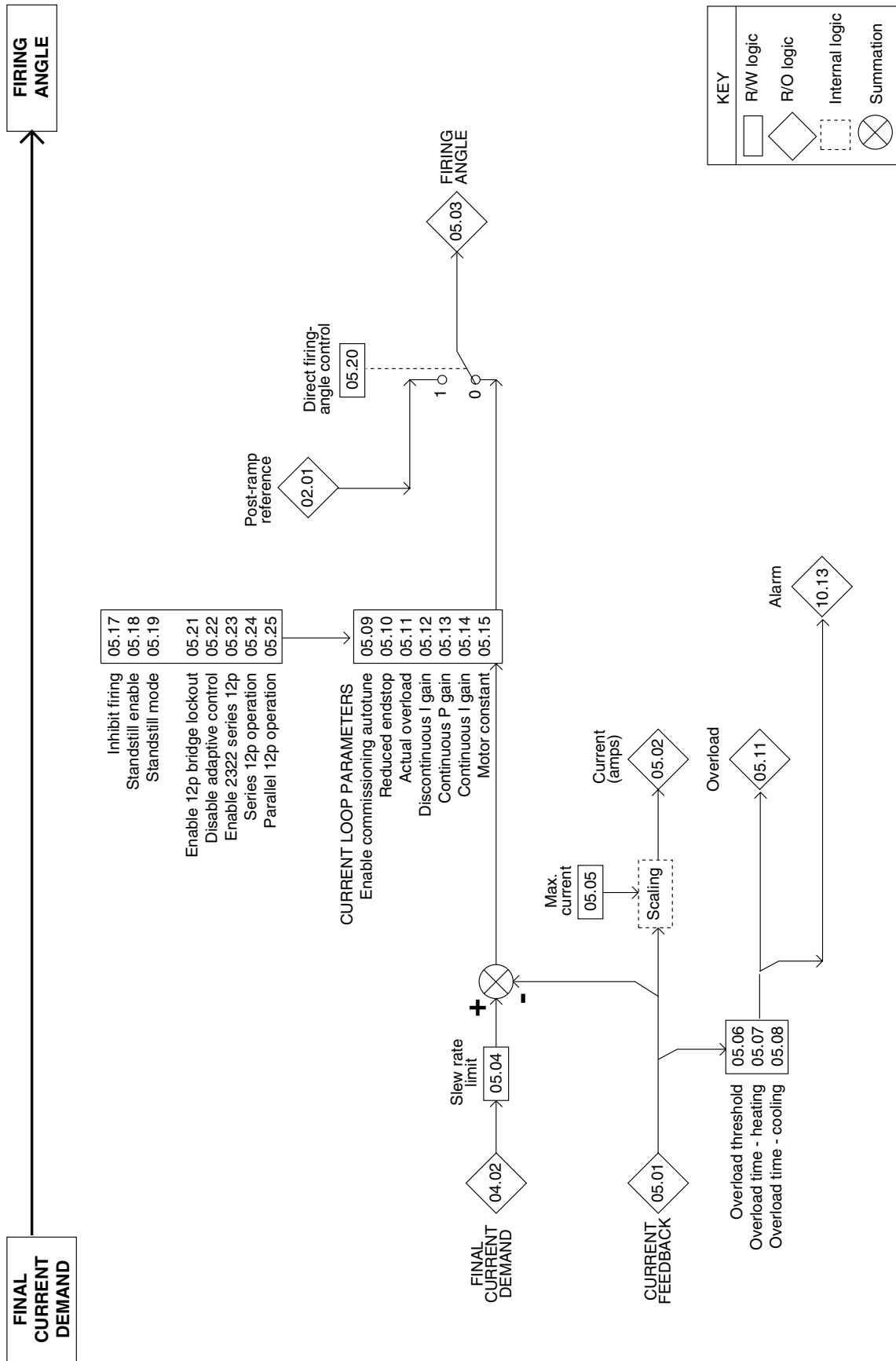

Three-phase controllers DMV 2322 / DMV 2342

3.4.6 - Menu 06 : Field control

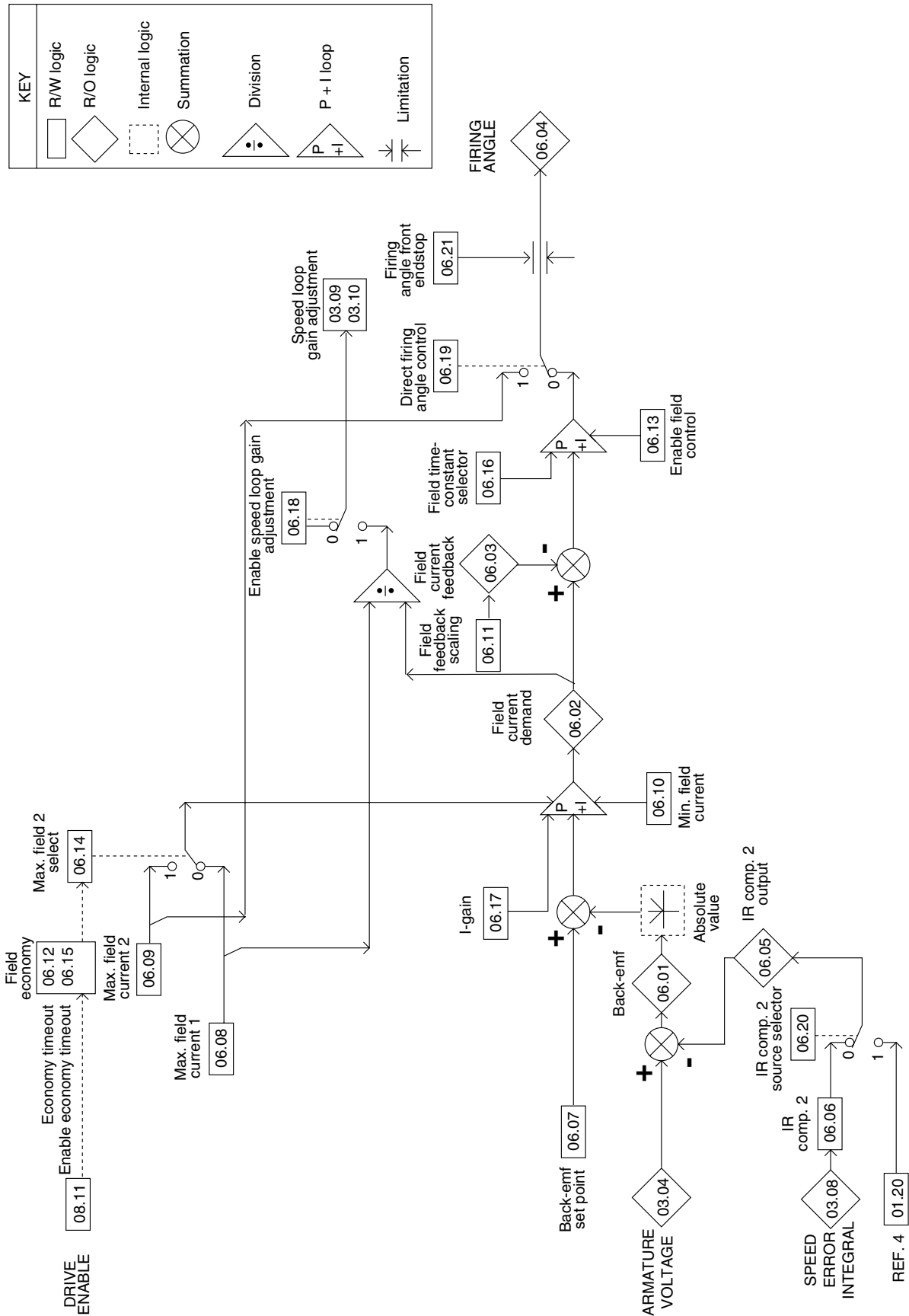

Three-phase controllers DMV 2322 / DMV 2342

3.4.7 - Menu 07 : Analogue inputs & outputs

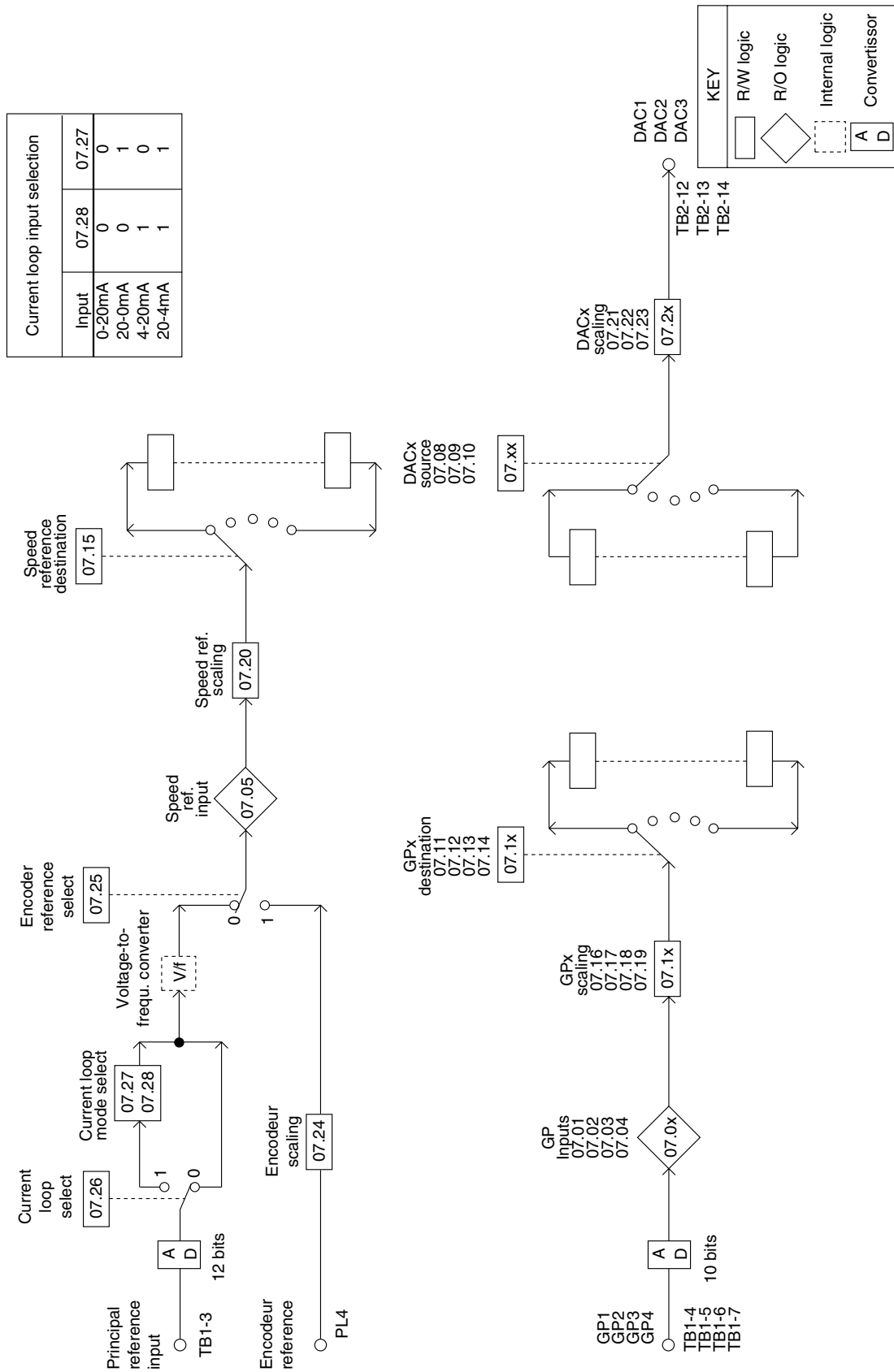

Three-phase controllers DMV 2322 / DMV 2342

3.4.8 - Menu 08 : Logic inputs

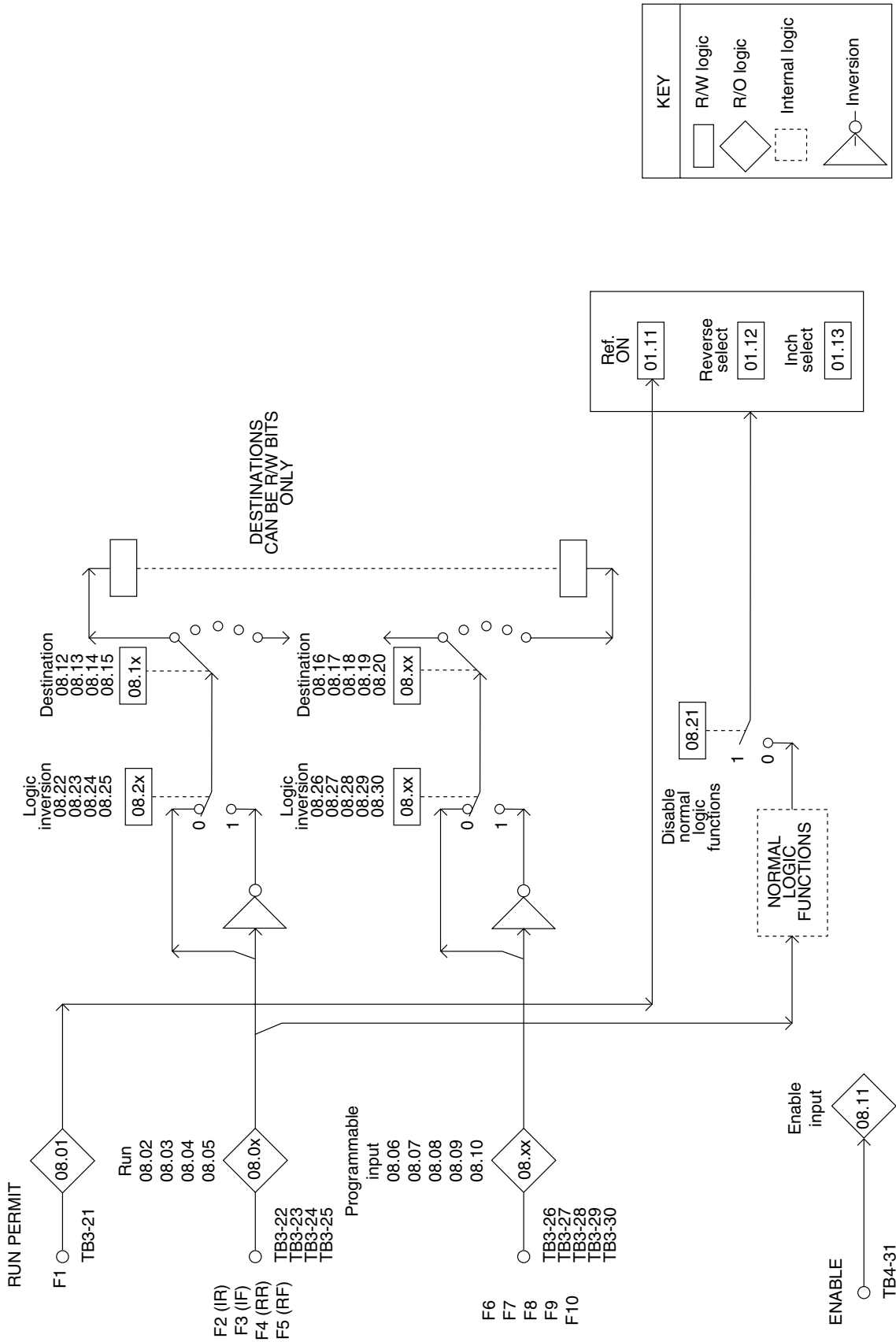

Three-phase controllers DMV 2322 / DMV 2342

3.4.9 - Menu 09 : Status outputs

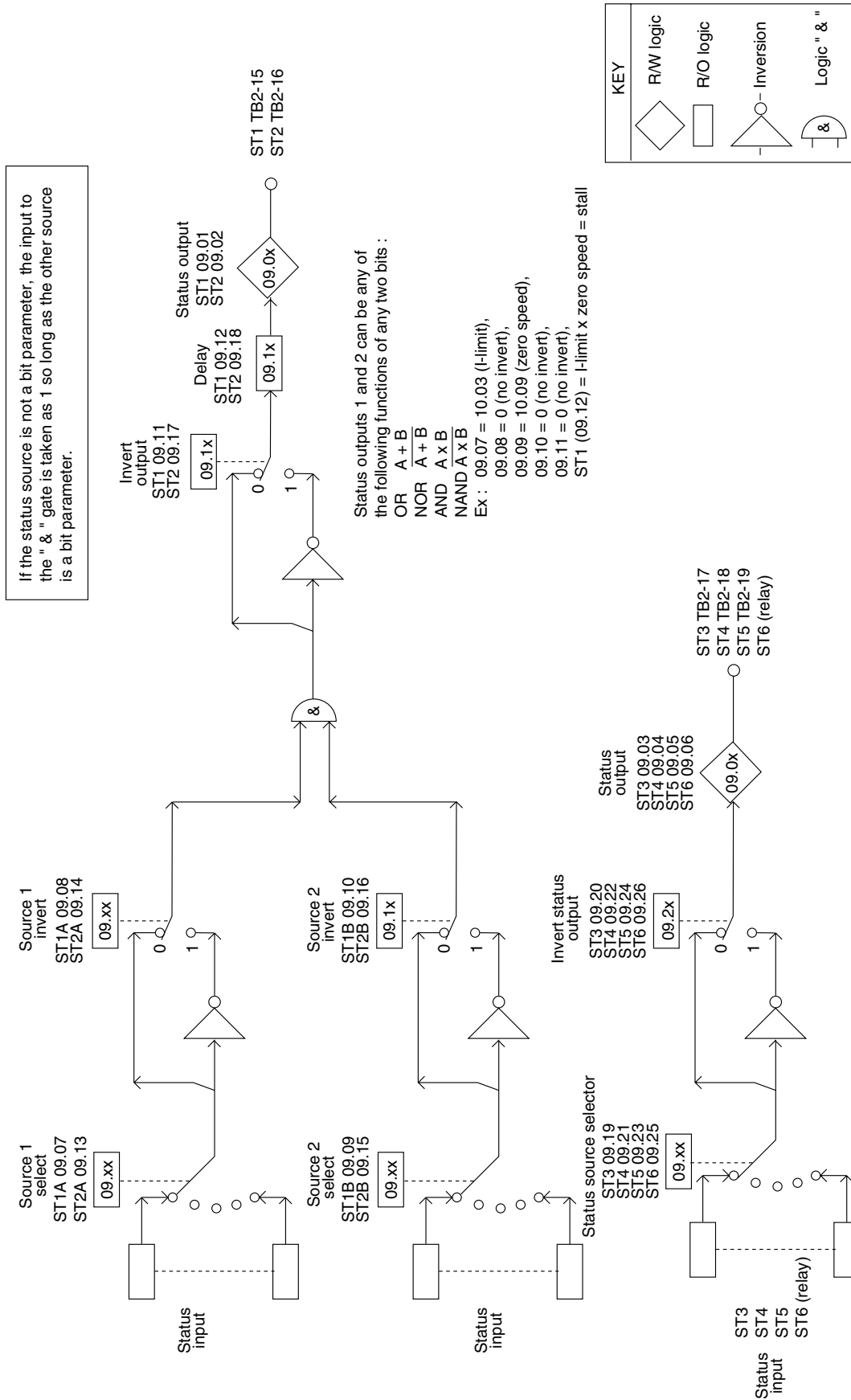

Three-phase controllers DMV 2322 / DMV 2342

3.4.10 - Menu 12 : Programmable thresholds

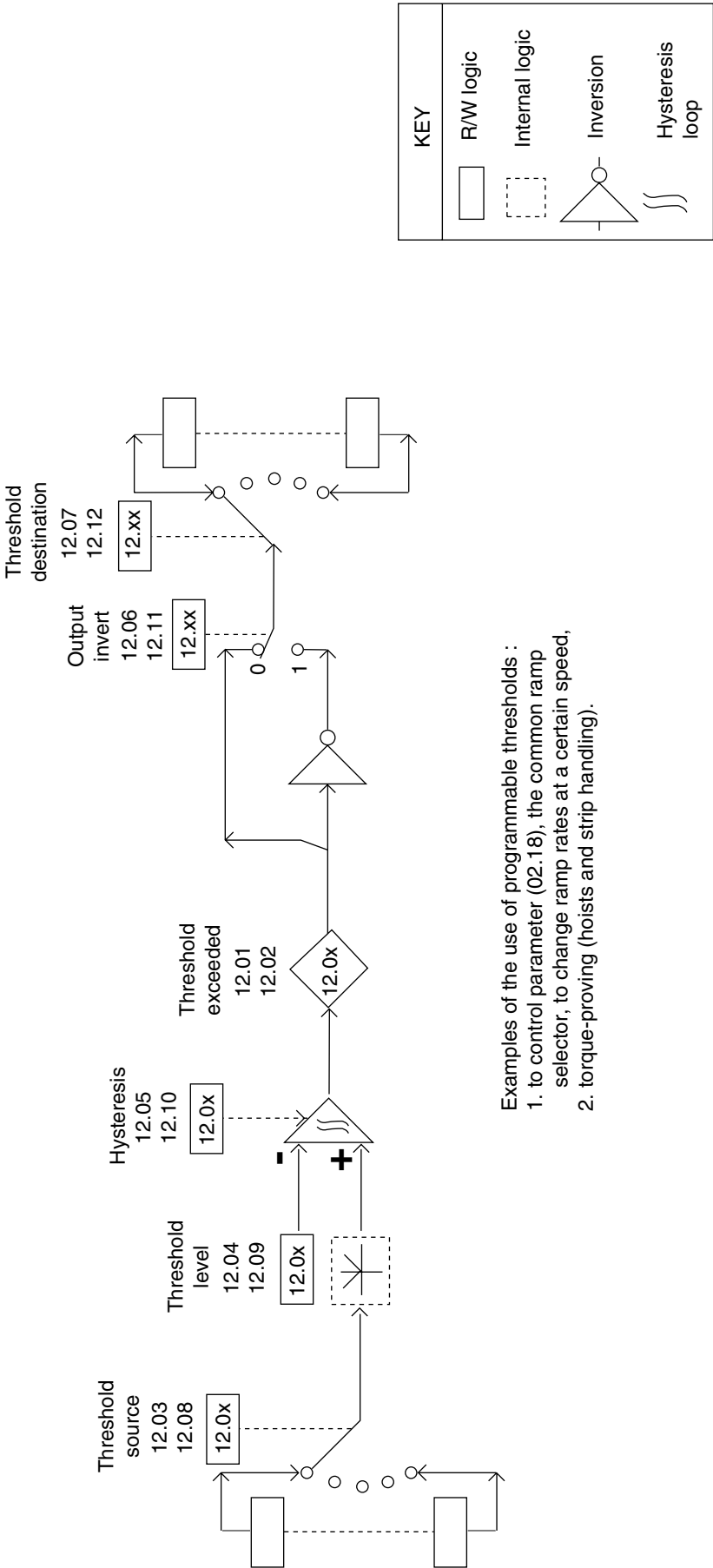

Three-phase controllers

DMV 2322 / DMV 2342

4 - DIAGNOSTIC PROCEDURES

Trip codes

If the drive trips, the index display shows **triP**, and the data message will flash. The data display shows a mnemonic to indicate the reason for the trip.

The last four trip codes are stored in parameters 10.25 through to 10.28, and are available for interrogation unaffected by power down/up cycles. The data stored in these parameters is updated only by the next trip event.

Mnemonic	Code	Reason for the trip
AOC	121	Armature overcurrent. An instantaneous protection trip has been activated due to excess current in the armature circuit.
AOP	126	Armature open circuit.
cL	104	Current (control) loop open circuit. If the input reference is either 4-20mA or 20-4mA, this trip indicates that input current is < 3.5mA.
EEF	132	EEprom failure. Indicates that an error has been detected in the parameter set read from the EEprom at power-up.
EPS	103	External power supply. Overcurrent trip at the 24V supply output terminal (TB4-33) has operated, indicating an overload in the external circuit connected to this supply. Investigate and rectify the cause.
Et	102	External trip. Parameter 10.34 = 1. The external trip set up by the user has operated.
FbL	119	Feedback loss. No signal from tachogenerator or encoder.
Fbr	109	Feedback reversal. The polarity of the feedback tacho or encoder polarity is incorrect.
FdL	118	Field loss. No current in field supply circuit.
FdO	108	Field on. The user has initiated self-tuning (05.09) and field current has been detected.
FOC	106	Field overcurrent. Excess current detected in field current feedback. If current feedback is present and firing angle is phased back, then trip.
hF	100	Hardware fault. A hardware fault has been detected during the self-diagnosis routine performed after power-up. Users are recommended to consult the supplier of the drive.

Mnemonic	Code	Reason for the trip
It	122	Ix t trip. The integrating overload protection has reached trip level.
Oh	107	Overheat. Thyristor stack overtemperature. (Only on drives fitted with stack thermistors).
Pc1	124	Processor 1 watchdog. Indicates a fault in the MDA1 hardware has been detected by malfunctioning of Processor 1 software.
Pc2	131	Processor 2 watchdog. Indicates a processor 2 malfunction, or a software bug (CAP - DMV option).
PhS	101	Phase sequence. Connections to E1 and E3 are not the same phases as are connected to L1 and L3. Investigate and correct.
PS	125	Power supply. One or more of the internal power supply rails is out of tolerance.
ScL	105	Serial communications link loss. (Only in serial comms mode 3). No input data detected.
SL	120	Supply loss. One or more of the power (input) supply phases is open-circuit.
th	123	Thermistor. Motor protection thermistor has initiated a trip indicating windings overheating.
thS	110	Thermistor short circuit. Thermistor input < 100 Ω.

In the event of any trip, all RO parameter values are " frozen " and remain so for interrogation while the cause of the fault is investigated. To enter parameter adjustment mode from the trip mode, press any of the five adjustment keys. To re-enter trip mode, go to Menu 00 and press \odot .