

LSA 43.2/44.2 - 4 POLES ALTERNATORS

Installation and maintenance

LSA 43.2/44.2 - 4 POLES ALTERNATORS

This manual concerns the alternator which you have just purchased.

We wish to draw your attention to the contents of this maintenance manual.

SAFETY MEASURES

Before using your machine for the first time, it is important to read the whole of this installation and maintenance manual.

All necessary operations and interventions on this machine must be performed by a qualified technician.

Our technical support service will be pleased to provide any additional information you may require.

The various operations described in this manual are accompanied by recommendations or symbols to alert the user to the potential risk of accidents. It is vital that you understand and take notice of the different warning symbols used.

WARNING

Warning symbol for an operation capable of damaging or destroying the machine or surrounding equipment.



Warning symbol for general danger to personnel.



Warning symbol for electrical danger to personnel.

WARNING SYMBOLS

We wish to draw your attention to the following 2 safety measures which must be complied with:

a) During operation, do not allow anyone to stand in front of the air outlet guards, in case anything is ejected from them.

b) Do not allow children younger than 14 to go near the air outlet guards.

A set of self-adhesive stickers depicting the various warning symbols is included with this maintenance manual. They should be positioned as shown in the drawing below once the machine has been fully installed.

WARNING

The alternators must not be put into service until the machines in which they are to be incorporated have been declared compliant with Directives EC and plus any other directives that may be applicable.

Note: LEROY-SOMER reserves the right to modify the characteristics of its products at any time in order to incorporate the latest technological developments. The information contained in this document may therefore be changed without notice.

Copyright 2005 :
MOTEURS LEROY-SOMER

It may not be reproduced in any form without prior authorization.
All brands and models have been registered and patents applied for.

LSA 43.2/44.2 - 4 POLES ALTERNATORS

CONTENTS

1 - RECEIPT	4
1.1 - Standards and safety measures	4
1.2 - Inspection	4
1.3 - Identification	4
1.4 - Storage	4
1.5 - Applications	4
1.6 - Contraindications to use	4
2 - TECHNICAL CHARACTERISTICS	5
2.1 - Electrical characteristics	5
2.2 - Mechanical characteristics	5
3 - INSTALLATION	6
3.1 - Assembly	6
3.2 - Checks prior to first use	7
3.3 - Terminal connection diagrams	7
3.4 - Commissioning	10
3.5 - Setting up	10
4 - SERVICING - MAINTENANCE	11
4.1 - Safety measures	11
4.2 - Routine maintenance	11
4.3 - Bearings	12
4.4 - Mechanical defects	12
4.5 - Electrical faults	12
4.6 - Dismantling, reassembly	14
4.7 - Installation & maintenance of the PMG	16
4.8 - Table of characteristics	16
5 - SPARE PARTS	18
5.1 - First maintenance parts	18
5.2 - Technical support service	18
5.3 - Exploded views, parts list and tightening torque	19
EC declaration of incorporation	22

LSA 43.2/44.2 - 4 POLES ALTERNATORS

1 - RECEIPT

1.1 - Standards and safety measures

Our alternators comply with most international standards.

See the EC Declaration of Incorporation on the last page.

1.2 - Inspection

On receipt of your alternator, check that it has not suffered any damage in transit. If there are obvious signs of knocks, contact the transporter (you may be able to claim on their insurance) and after a visual check, turn the machine by hand to detect any malfunction.

1.3 - Identification

The alternator is identified by means of a nameplate fixed on the machine (see drawing).

Make sure that the nameplate on the machine conforms to your order.

1.4 - Storage

Prior to commissioning, machines should be stored :

- away from humidity (< 90%); after a long period of storage, check the machine insulation. To prevent the bearings from becoming marked, do not store in an environment with significant vibration.

1.5 - Application

These alternators are mainly designed to produce electricity in the context of applications involving the use of generators.

1.6 - Contraindications to use

Use of the machine is restricted to operating conditions (environment, speed, voltage, power, etc) compatible with the characteristics indicated on the nameplate.



Nameplate

So that you can identify your machine quickly and accurately, we suggest you write its specifications on the nameplate below.

The machine name is defined according to various criteria, for example :

LSA 43.2 M45 J6/4

- LSA : name used in the PARTNER range
- M : Marine - C : Cogeneration - T : Telecommunications
- 43.2 : machine type
- M45 : model
- J : excitation system (C : AREP / J : SHUNT or PMG)
- 6/4 : winding number / number of poles.

LEROY-SOMER		PARTNER		ALTERNATORS	
LSA		IP		RATINGS	
N°:		Date :		Voltage	
r.p.m.		Hz		Phase	
Weight :		kg		Conn.	
P.F. :		Th.class.		Altitude : m	
A.V.R.		Excit.		Contin.	
Excit. values		full load : V / A		B.R.	
		at no load : A		40°C.	
D.E. bearing				Std by	
N.D.E. bearing				P.R.	
				27°C.	
<small>166631</small>		<small>ISO 8528-3</small>		<small>Made in</small>	
IEC 60034-1 & 5		NEMA MG1-32 & 33		www.leroy-somer.com	
				1.025.002 a	

LSA 43.2/44.2 - 4 POLES ALTERNATORS

2 - TECHNICAL CHARACTERISTICS

2.1 - Electrical characteristics

The LSA 43.2/44.2 alternator is a machine without sliprings or revolving armature brushes, wound as "2/3 pitch", 12-wire, with class H insulation and a field excitation system available in either SHUNT, AREP or «PMG» version (see diagrams and AVR manuals).

• Electrical options

- Stator temperature detection sensors
- Space heater

Interference suppression conforms to standard EN 55011, group 1, class B (Europe).

2.2 - Mechanical characteristics

- Steel frame
- Cast iron end shields
- Protected ball bearings, greased for life
- Mounting arrangements:
IM 1201 (MD 35) foot and flange mounted, single-bearing with SAE coupling disc.
IM 1001 (B 34) double-bearing with SAE flange and standard cylindrical shaft extension.
- Drip-proof machine, self-cooled
- Degree of protection: IP 23

• Mechanical options

- Air inlet filter
- Regreasable ball bearings (only for LSA 44.2 and SHUNT or AREP version)
- IP 44 protection

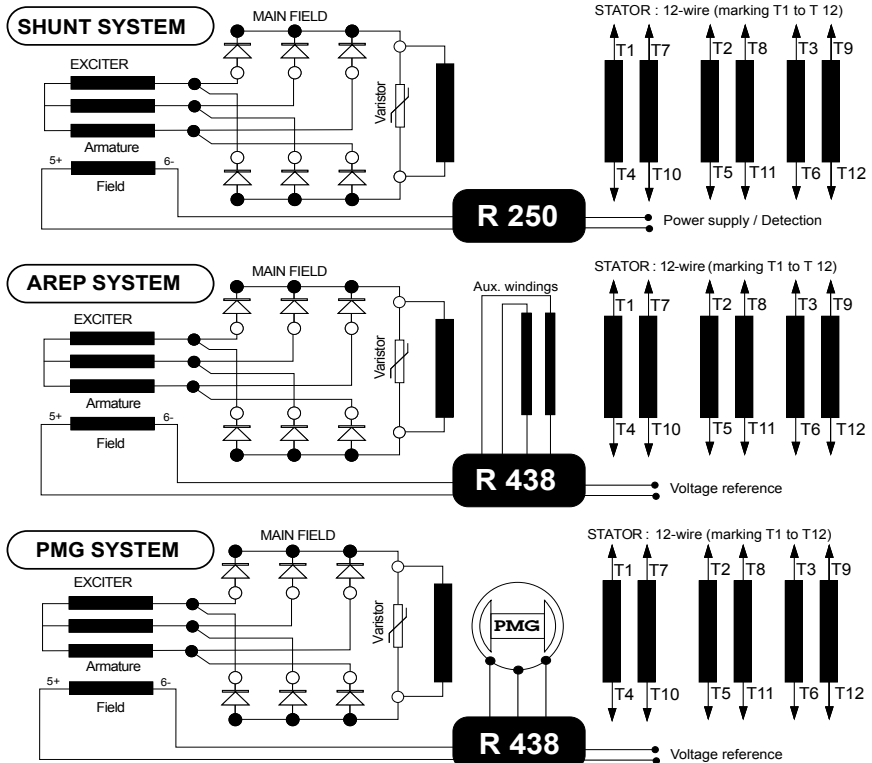

LSA 43.2/44.2 - 4 POLES ALTERNATORS

3 - INSTALLATION

Personnel undertaking the various operations indicated in this section must wear personal protective equipment appropriate for mechanical and electrical hazards.

3.1 - Assembly



All mechanical handling operations must be undertaken using suitable equipment and the machine must be horizontal. Check how much the machine weighs (see 4.7) before choosing the lifting tool.

During this operation, do not allow anyone to stand under the load.

• Handling

The generously-sized lifting rings are for handling the alternator alone. They must not be used to lift the genset. The choice of lifting hooks or handles should be determined by the shape of these rings. Choose a lifting system which respects the integrity and the environment of the machine.

During this operation, do not allow anyone to stand under the load.

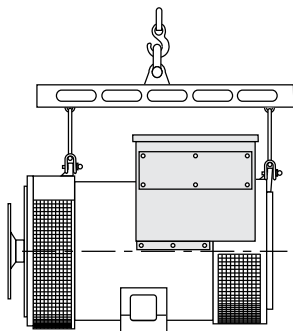

• Coupling

Single-bearing alternator

Before coupling the machines, check that they are compatible by:

- undertaking a torsional analysis of the transmission,
- checking the dimensions of the flywheel and its housing, the flange, coupling discs and offset.

WARNING

When coupling the alternator to the prime mover, do not use the fan to turn the alternator or rotor.

The holes of the coupling discs should be aligned with the flywheel holes by cranking the engine.

Make sure the machine is securely bedded in position during coupling.

Check that there is lateral play on the crankshaft.

Double-bearing alternator

- Semi-flexible coupling

Careful alignment of the machines is recommended, checking that the lack of concentricity and parallelism of both parts of the coupling do not exceed 0.1 mm.

This alternator has been balanced with a 1/2 key.

• Location

The room where the alternator is placed must be ventilated to ensure that the ambient temperature cannot exceed the data on the nameplate.

3.2 - Checks prior to first use

• Electrical checks



Under no circumstances should an alternator, new or otherwise, be operated if the insulation is less than 1 megohm for the stator and 100,000 ohms for the other windings.

LSA 43.2/44.2 - 4 POLES ALTERNATORS

There are 2 possible methods for restoring the above minimum values.

a) Dry out the machine for 24 hours in a drying oven at a temperature of 110 °C (without the regulator).

b) Blow hot air into the air intake, having made sure that the machine is rotating with the exciter field disconnected.

Note : Prolonged standstill

In order to avoid these problems, we recommend the use of space heaters, as well as turning over the machine from time to time. Space heaters are only really effective if they are working continuously while the machine is stopped.

WARNING

Ensure that the alternator has the degree of protection matching the defined environmental conditions.

• Mechanical checks

Before starting the machine for the first time, check that:

- all fixing bolts and screws are tight,

- the cooling air is drawn in freely,
- the protective grilles and housing are correctly in place,
- the standard direction of rotation is clockwise as seen from the shaft end (phase rotation in order 1 - 2 - 3).

For anti-clockwise rotation, swap 2 and 3.
- the winding connection corresponds to the site operating voltage (see section 3.3).

3.3 - Terminal connection diagrams



To modify the connection, change the position of the stator cables on the terminals. The winding code is specified on the nameplate.



Any intervention on the alternator terminals during reconnection or checks should be performed with the machine stopped.

Connection codes		L.L. voltage		Factory connection	
A 3 phases 	Winding	50 Hz	60 Hz		
	6	190 - 208	190 - 240		
	7	220 - 230	-		
	8	-	190 - 208		
R 250 voltage sensing: 0 => (T8) / 110 V => (T11) R 438 voltage sensing: 0 => (T3) / 110 V => (T2)					
D 3 phases 	Winding	50 Hz	60 Hz		
	6	380 - 415	380 - 480		
	7	440 - 460	-		
	8	-	380 - 416		
R 250 voltage sensing: 0 => (T8) / 110 V => (T11) R 438 voltage sensing: 0 => (T3) / 380 V => (T2)					

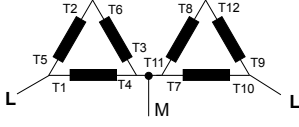
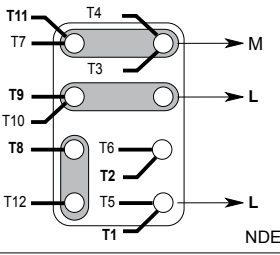
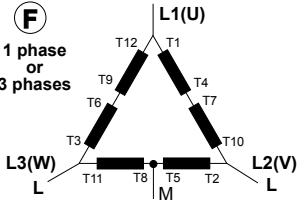
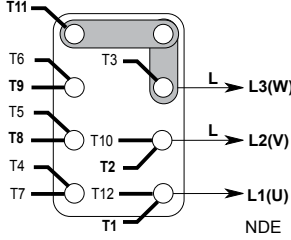
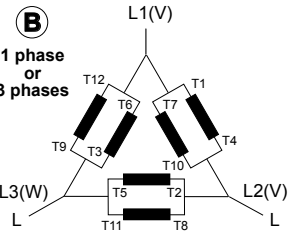
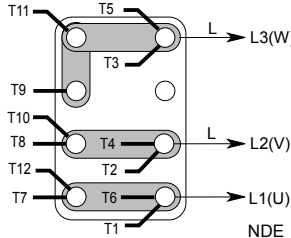
LSA 43.2/44.2 - 4 POLES ALTERNATORS

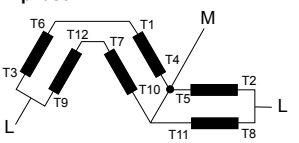
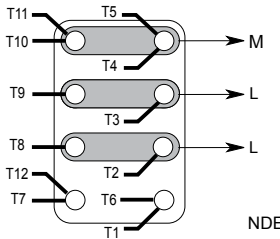
Connection codes		L.L. voltage			Factory connection	
FF 1 phase  LM voltage = 1/2 LL voltage	Winding	50 Hz	60 Hz			
	6	220 - 240	220 - 240			
	7	250 - 260	-			
	8	200	220 - 240			
		R 250 voltage sensing: 0 => (T1) / 110 V => (T4) R 438 voltage sensing: 0 => (T10) / 220 V => (T1)				
F 1 phase or 3 phases  LM voltage = 1/2 LL voltage	Winding	50 Hz	60 Hz			
	6	220 - 240	220 - 240			
	7	250 - 260	-			
	8	200	220 - 240			
		R 250 voltage sensing: 0 => (T8) / 110 V => (T11) R 438 voltage sensing: 0 => (T3) / 220 V => (T2)				
B 1 phase or 3 phases  LM voltage = 1/2 LL voltage	Winding	50 Hz	60 Hz			
	6	110 - 120	120			
	7	120 - 130	-			
	8	-	110 - 120			
		R 250 voltage sensing: 0 => (T8) / 110 V => (T11) R 438 voltage sensing: 0 => (T3) / 110 V => (T2)				
 FOR LSA 44.2, THE COUPLING B IS NOT POSSIBLE						
G 1 phase Connection not recommended  LM voltage = 1/2 LL voltage	Winding	50 Hz	60 Hz			
	6	220 - 240	220 - 240			
	7	250 - 260	-			
	8	200	220 - 240			
		R 250 voltage sensing: 0 => (T8) / 110 V => (T11) R 438 voltage sensing: 0 => (T3) / 220 V => (T2)				

LSA 43.2/44.2 - 4 POLES ALTERNATORS

SINGLE-PHASE 4-WIRE - type M or M1 DEDICATED WINDING

SERIAL CONNECTION

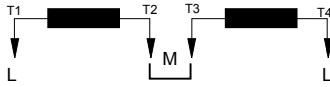

Voltage 50/60Hz		Link	Output		
L - L	L - M		L	L	M
220	110	T2 - T3	T1	T4	T2 - T3
230	115				
240	120				

R 251 voltage sensing: 0 => (T1) / 110 V => (T2)

PARALLEL CONNECTION (Not possible with LSA 44.2)

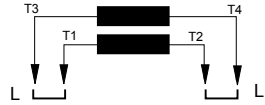

Voltage 50/60Hz		Link	Output		
L - L	L - M		L	L	M
110	-	T1 - T3 T2 - T4	T1-T3	T2 - T4	-
115	-				
120	-				

R 251 voltage sensing: 0 => (T1) / 110 V => (T2)

• Exciter field connection

Series connection (shunt excitation)

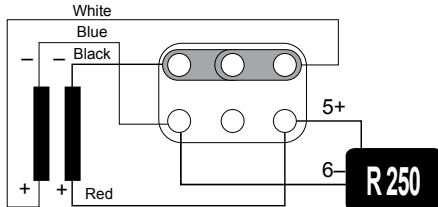

Parallel connection (AREP or PMG excitation)

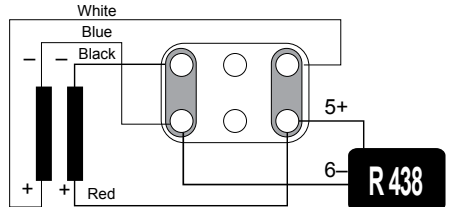

Single-phase dedicated SHUNT version: R 251 AVR (2-wire output without terminal block)

• Option connection diagram

R 791 T interference suppression kit (standard for CE marking)

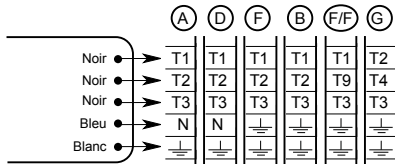

Voltage potentiometer

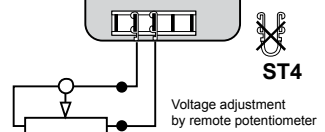

Anti condensation heater

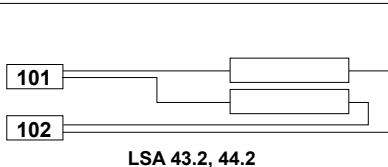

Thermistor (PTC) temperature

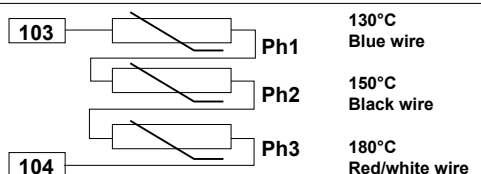

LSA 43.2/44.2 - 4 POLES ALTERNATORS

• Connection checks



Electrical installations must comply with the current legislation in force in the country of use.

Check that:

- The residual circuit-breaker conforms to legislation on protection of personnel, in force in the country of use, and has been correctly installed on the alternator power output as close as possible to the alternator. (In this case, disconnect the wire of the interference suppression module linking the neutral).
- Any protection devices in place have not been tripped.
- If there is an external AVR, the connections between the alternator and the cabinet are made in accordance with the connection diagram.
- There is no short-circuit phase-phase or phase-neutral between the alternator output terminals and the generator set control cabinet (part of the circuit not protected by circuitbreakers or relays in the cabinet).
- The machine should be connected with the busbar separating the terminals as shown in the terminal connection diagram.



- The alternator earth terminal inside the terminal box is connected to the electrical earth circuit
 - The earth terminal (ref 28) is connected to the frame.
- The connections inside the terminal box must never be subjected to stress due to cables connected by the user.

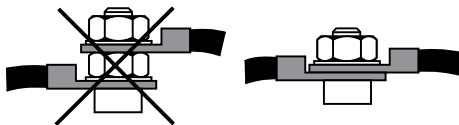

3.4 - Commissioning



The machine can only be started up and used if the installation is in accordance with the regulations and instructions defined in this manual.

The machine is tested and set up at the factory. When first used with no load, make sure that the drive speed is correct and stable (see the nameplate). With the regreasable bearing option, we recommend greasing the bearings at the time of commissioning (see section 4.2).

On application of the load, the machine should achieve its rated speed and voltage; however, in the event of abnormal operation, the machine setting can be altered (follow the adjustment procedure in section 3.5). If the machine still operates incorrectly, the cause of the malfunction must be located (see section 4.4).

3.5 - Setting up



The various adjustments during tests must be made by a qualified engineer. Ensure that the drive speed specified on the nameplate is reached before commencing adjustment.

After operational testing, replace all access panels or covers.

The AVR is used to make any adjustments to the machine.

LSA 43.2/44.2 - 4 POLES ALTERNATORS

4 - SERVICING - MAINTENANCE

4.1 - Safety measures

Servicing or troubleshooting must be carried out strictly in accordance with instructions so as to avoid the risk of accidents and to maintain the machine in its original state.



All such operations performed on the alternator should be undertaken by personnel trained in the commissioning, servicing and maintenance of electrical and mechanical components, who must wear personal protective equipment appropriate for mechanical and electrical hazards.

Before any intervention on the machine, ensure that it cannot be started by a manual or automatic system and that you have understood the operating principles of the system.



Warning : During and after running, the alternator will reach temperatures hot enough to cause injury, such as burns.

4.2 - Routine maintenance

• Checks after start-up

After approximately 20 hours of operation, check that all fixing screws on the machine are still tight, plus the general state of the machine and the various electrical connections in the installation.

• Electrical servicing

Commercially-available volatile degreasing agents can be used.

WARNING

Do not use: trichlorethylene, perchlorethylene, trichloroethane or any alkaline products.



These operations must be performed at a cleaning station, equipped with a vacuum system that collects and flushes out the products used.

The insulating components and the impregnation system are not at risk of damage from solvents. Avoid letting the cleaning product run into the slots.

Apply the product with a brush, sponging frequently to avoid accumulation in the housing. Dry the winding with a dry cloth. Let any traces evaporate before reassembling the machine.

• Mechanical servicing

WARNING

Cleaning the machine using water or a highpressure washer is strictly prohibited. Any problems arising from such treatment are not covered by our warranty.

Degreasing: Use a brush and detergent (suitable for paintwork).

Dusting: Use an air gun.

If the machine is fitted with air inlet and outlet filters, the maintenance personnel should clean them routinely at regular intervals. In the case of dry dust, the filter can be cleaned using compressed air and/or replaced if it is clogged.

After cleaning the alternator, it is essential to check the winding insulation (see sections 3.2 and 4.8).

LSA 43.2/44.2 - 4 POLES ALTERNATORS

4.3 - Bearings

The bearings are permanently greased	Approximate life of the grease (depending on use) = 20,000 hours or 3 years.
As an option, the bearings are regreasable	Regreasing interval: 6000 hrs of operation DE bearing: Amount of grease: 30 gr NDE bearing: Amount of grease: 15 gr
Standard grease	LITHIUM - standard - NLGI 3
Grease used in the factory	ESSO - Unirex N3
 It is advisable to lubricate the alternator during operation and on first use. Before using another grease, check for compatibility with the original one.	

4.4 - Mechanical defects

Fault		Action
Bearing	Excessive overheating of one or both bearings (bearing temperature 80°C above the ambient temperature) (With or without abnormal bearing noise)	<ul style="list-style-type: none"> - If the bearing has turned blue or if the grease has turned black, change the bearing. - Bearing not fully locked (abnormal play in the bearing cage) - End shields incorrectly aligned
Abnormal temperature	Excessive overheating of alternator frame (more than 40° C above the ambient temperature)	<ul style="list-style-type: none"> - Air flow (inlet-outlet) partially clogged or hot air is being recycled from the alternator or engine - Alternator operating at too high a voltage (>105% of Un on load) - Alternator overloaded
Vibrations	Too much vibration	<ul style="list-style-type: none"> - Misalignment (coupling) - Defective mounting or play in coupling - Rotor balancing fault (Engine - Alternator)
	Excessive vibration and humming noise coming from the machine	<ul style="list-style-type: none"> - Phase imbalance - Stator short-circuit
Abnormal noise	Alternator damaged by a significant impact, followed by humming and vibration	<ul style="list-style-type: none"> - System short-circuit - Misparalleling <p>Possible consequences</p> <ul style="list-style-type: none"> - Broken or damaged coupling - Broken or bent shaft end - Shifting and short-circuit of main field - Fan fractured or coming loose on shaft - Irreparable damage to rotating diodes/AVR, surge suppressor

LSA 43.2/44.2 - 4 POLES ALTERNATORS

4.5 - Electrical faults

Fault	Action	Effect	Check/Cause
No voltage at no load on start-up	Connect a new battery of 4 to 12 volts to terminals E- and E+, respecting the polarity, for 2 to 3 seconds	The alternator builds up and its voltage is still correct when the battery is removed	- Lack of residual magnetism
		The alternator builds up but its voltage does not reach the rated value when the battery is removed	- Check the connection of the voltage reference to the AVR - Faulty diodes - Armature short-circuit
		The alternator builds up but its voltage disappears when the battery is removed	- Faulty AVR - Field windings open circuit (check winding) - Revolving field coil open circuit (check the resistance)
Voltage too low	Check the drive speed	Correct speed	Check the AVR connections (AVR may be faulty) - Field windings short-circuited - Rotating diodes burnt out - Revolving field coil short-circuited - Check the resistance
		Speed too low	Increase the drive speed (do not touch the AVR voltage pot. (P2) before running at the correct speed)
Voltage too high	Adjust AVR voltage potentiometer	Adjustment ineffective	Faulty AVR
Voltage oscillations	Adjust the AVR stability potentiometer	If no effect: try normal or fast stability modes (ST2)	- Check the speed: possibility of cyclic irregularity - Loose connections - Faulty AVR - Speed too low when on load (or AVR LAM set too high)
Voltage correct at no load and too low when on load	Run at no load and check the voltage between E+ and E- on the AVR	Voltage between E+ and E- (DC) SHUNT < 20V - AREP / PMG < 10V	- Check the speed (or AVR LAM set too high)
		Voltage between E+ and E- SHUNT > 30V - AREP / PMG > 15V	- Faulty rotating diodes - Short-circuit in the revolving field coil. Check the resistance. - Faulty exciter armature. Check the resistance.
Voltage disappears during operation	Check the AVR, the surge suppressor, the rotating diodes, and replace any defective components	The voltage does not return to the rated value	- Exciter winding open circuit - Faulty exciter armature - Faulty AVR - Revolving field coil open circuit or short-circuited

LSA 43.2/44.2 - 4 POLES ALTERNATORS

• Checking the winding

You can check the winding insulation by performing a high voltage test. In this case, you must disconnect all AVR wires.

WARNING

Damage caused to the AVR in such conditions is not covered by our warranty.

4.5.2 - Checking the diode bridge

A diode in good working order should allow the current to flow only in the anode-to-cathode direction.

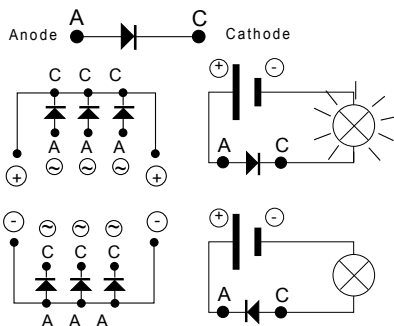

• Checking the windings and rotating diodes using separate excitation



During this procedure, make sure that the alternator is disconnected from any external load and inspect the terminal box to check that the connections are fully tightened.

1) Stop the unit, disconnect and isolate the AVR wires.

2) There are two ways of creating an assembly with separate excitation.

Assembly A: Connect a 12 V battery in series with a rheostat of approximately 50 ohms - 300 W and a diode on both exciter field wires (5+) and (6-).

ASSEMBLY A

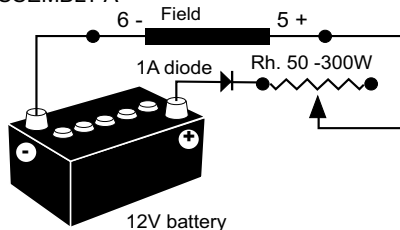

Assembly B: Connect a "Variac" variable power supply and a diode bridge on both exciter field wires (5+) and (6-).

Both these systems should have characteristics which are compatible with the field excitation power of the machine (see the nameplate).

3) Run the unit at its rated speed.

4) Gradually increase the exciter field current by adjusting the rheostat or the variac and measure the output voltages on L1 - L2 - L3, checking the excitation voltage and current at no load (see the machine nameplate or ask for the factory test report). When the output voltage is at its rated value and balanced within 1% for the rated excitation level, the machine is in good working order. The fault therefore comes from the AVR or its associated wiring (ie. sensing, auxiliary windings).

ASSEMBLY B

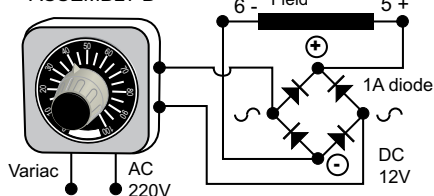

LSA 43.2/44.2 - 4 POLES ALTERNATORS

4.6 - Dismantling, reassembly

WARNING

During the warranty period, this operation should only be carried out in an LEROY-SOMER approved workshop or in our factory, otherwise the warranty may be invalidated.

Whilst being handled, the machine should remain horizontal (rotor not locked in position). Check how much the machine weighs before choosing the lifting method.

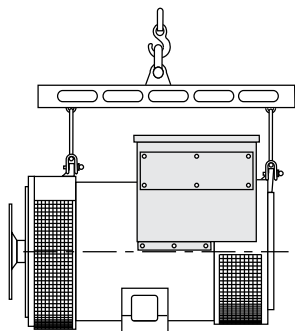

• Tools required

To fully dismantle the machine, we recommend using the tools listed below:

- 1 ratchet spanner + extension
- 1 torque wrench
- 1 set of flat spanners: 7, 8, 10, 12 mm
- 1 socket set: 8, 10, 13, 16, 18, 21, 22, 24 mm
- 1 size: 5 Allen key (eg. Facom: ET5), 6 Allen key (ET6), 10 Allen key (ET10), 14 Allen key (ET14)
- 1 T20 and T30 TORX bit
- 1 puller (U35) / (U32/350).

• Screw tightening torque

See section 5.4.

• Access to diodes

- Remove the air intake grille [51]
- Remove the surge suppressor [347]
- Disconnect the 6 diodes using an ohmmeter or a battery lamp (see section 4.5.2)
- Replace the bridges, respecting the polarity (see section 4.5.1)
- Replace the surge suppressor [347]

- Refit the air intake grille [51]
- Replace the terminal box lid [48]

• Access to connections and the regulation system

The terminals are accessed directly by removing the terminal box lid [48]. To access the AVR adjustment potentiometers, the side plate [367] should be removed.

• Replacing the NDE bearing

- Dismantling

- Remove the terminal box lid [48]
- Remove the air intake grille [51]
- Unscrew the fixing clamps on the power output cables, remove the connector from the exciter and the R 791 module.
- Remove the 4 nuts on the tie rods
- Remove the NDE shield [36] using a puller: eg. U.32 - 350 (FACOM)
- Remove the ball bearing [70] using a screw puller.

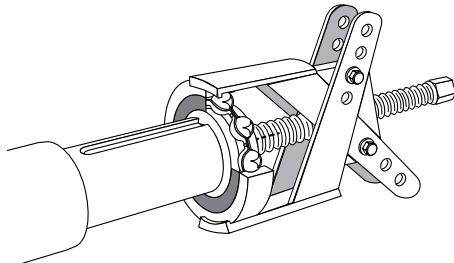

- Reassembly

- Heat the inner slipping of a new bearing by induction or in a drying oven at 80 °C (do not use an oil-bath) and fit it to the machine.
- Place the preloading wavy washer [79] in the shield and fit a new O ring seal [349]. Refit the NDE shield and pass the bundle of wires between the top bars of the shield.
- Refit the fixing clamps on the cables, the R 791 module and the exciter connector.
- Refit the air intake grille [51].
- Replace the terminal box lid [48].

LSA 43.2/44.2 - 4 POLES ALTERNATORS

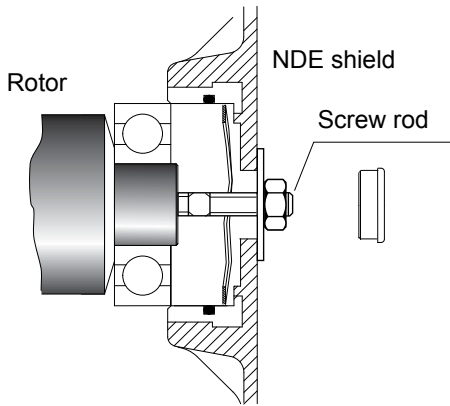

WARNING

When dismantling the shields, you will need to change the antifriction bearings, the “O” ring seal, the preloading (wavy) washer and adhesive paste.

• Replacing the DE bearing

- Dismantling

- Uncouple the alternator from the prime mover.
- Remove the 8 assembly screws.
- Remove the DE shield [30].
- Remove the NDE shield (see section 4.6.5.1)
- Remove both ball bearings [60] and [70] using a puller with a central screw.

- Reassembly

- Heat the new bearings by induction or in a drying oven at 80°C (do not use an oil-bath) and fit them to the machine.
- Check that both the preloading wavy washer [79] and the new O ring seal [349] have been fitted on the NDE shield [36]. Refit the NDE shield and pass the bundle of wires between the top bars of the shield.
- Refit the DE shield [30] and tighten the 4 fixing screws.
- Check that the machine assembly is correctly mounted and that all screws are tightened.

• Accessing the main field and stator

- Dismantling

- Follow the procedure for dismantling the bearings (see sections 4.6.5.1 and 4.6.6.1)
 - Remove the coupling disc (single-bearing alternator) or the DE shield (two-bearing alternator) and insert a tube of the corresponding diameter on the shaft end.
 - Rest the rotor on one of its poles, then slide it out. Use the tube as a lever arm to assist dismantling.
 - After extraction of the rotor, be careful not to damage the fan. If the fan is dismantled, it is essential that it is replaced for the 43.2.
- NOTE: If intervention is required on the main field (rewinding, replacement of components), the rotor assembly must be rebalanced.**

- Reassembling the main field

- Follow the dismantling procedure in reverse order.
- Take care not to knock the windings when refitting the rotor in the stator.
- If the fan is being replaced on the 43.2, assemble the parts as shown in the following diagram. Fit a tube and a threaded screw. On the 44.2 the fan is fixed by screws on the hub.

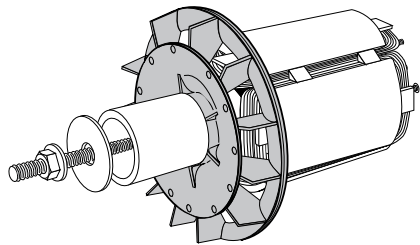

Follow the procedure for reassembling the bearings (see sections 4.6.5.2 and 4.6.6.2).

LSA 43.2/44.2 - 4 POLES ALTERNATORS

4.7 - Installation and maintenance of the PMG

For the LSA 43.2 and LSA 44.2, the PMG reference is PMG 1.

See the PMG maintenance manual, ref: 4211.

WARNING

Mounting is impossible with the «regreasable bearings» option with the LSA 44.2.

4.8 - Table of characteristics

Table of average values:

Alternator - 2 and 4 poles - 50 Hz/60 Hz - Winding n° 6 and M or M1 connected in dedicated single-phase. (400 V for the excitation values).

The voltage and current values are given for no-load operation and operation at rated load with separate field excitation. All values are given at $\pm 10\%$ (for exact values, consult the test report) and are subject to change without prior warning. For 60 Hz machines, the resistance values are the same and the excitation current «i exc» is approximately 5 to 10% weaker.

• 3-phase LSA 43.2 4 P, SHUNT excitation

Resistances at 20 °C (Ω)

LSA 43.2	Stator L/N	Rotor	Field	Armature
S1	0.155	1.35	18.4	0.23
S15	0.155	1.35	18.4	0.23
S25	0.155	1.35	18.4	0.23
S35	0.128	1.41	18.4	0.23
M45	0.105	1.57	18.4	0.23
L65	0.083	1.76	18.4	0.23
L8	0.063	1.96	18.4	0.23

Field excitation current i exc (A) - 400 V - 50 Hz

«i exc»: excitation current of the exciter field

LSA 43.2	no load	at load
S1	0.5	1.3
S15	0.5	1.5
S25	0.5	1.6
S35	0.5	1.8
M45	0.4	1.6
L65	0.4	1.6
L8	0.4	1.6

• 3-phase LSA 43.2 4 P, AREP excitation

Resistances at 20 °C (Ω)

LSA 43.2	Stator L/N	Rotor	Wind. X1,X2	Wind. Z1,Z2	Field	Armat.
S1	0,155	1,35	0,32	0,52	4,6	0,23
S15	0,155	1,35	0,32	0,52	4,6	0,23
S25	0,155	1,35	0,32	0,52	4,6	0,23
S35	0,128	1,41	0,29	0,5	4,6	0,23
M45	0,105	1,57	0,26	0,51	4,6	0,23
L65	0,083	1,76	0,26	0,44	4,6	0,23
L8	0,063	1,96	0,21	0,4	4,6	0,23

Field excitation current i exc (A) - 400 V - 50 Hz

«i exc»: excitation current of the exciter field

LSA 43.2	no load	at load
S1	1	2,6
S15	1	3
S25	1	3,2
S35	1	3,6
M45	0,8	3,2
L65	0,8	3,2
L8	0,8	3,2

• Dedicated single-phase LSA 43.2:

4-pole, SHUNT excitation (60 Hz only)

Resistances at 20 °C (Ω)

LSA 43.2	Stator L/N	Rotor	Field	Armature
S1	0,058	1,35	13,9	0,23
S25	0,058	1,35	13,9	0,23
S35	0,046	1,41	13,9	0,23
M45	0,037	1,57	13,9	0,23
L65	0,027	1,76	13,9	0,23
L8	0,019	1,96	13,9	0,23

Field excitation current i exc (A) - 240 V - 60 Hz

«i exc»: excitation current of the exciter field

LSA 43.2	no load	at load
S1	0,59	1,44
S25	0,59	1,68
S35	0,66	1,65
M45	0,61	1,48
L65	0,62	1,48
L8	0,74	1,46

LSA 43.2/44.2 - 4 POLES ALTERNATORS

• 3-phase LSA 44.2: 4-pole, SHUNT excitation

Resistances at 20 °C (Ω)

LSA 44.2	Stator L/N	Rotor	Field	Armature
VS3	0.046	2.51	18.4	0.5
VS45	0.046	2.51	18.4	0.5
S7	0.036	2.91	18.4	0.5
S75	0.036	2.91	18.4	0.5
M95	0.024	3.32	18.4	0.5
L12	0.019	3.66	18.4	0.5

Field excitation current i_{exc} (A) - 400 V - 50 Hz

« i_{exc} »: excitation current of the exciter field

LSA 44.2	no load	at load
VS3	0.5	1.8
VS45	0.5	2.1
S7	0.5	1.9
S75	0.5	2.1
M95	0.6	2
L12	0.5	1.9

• 3-phase LSA 44.2: 4-pole, AREP excitation

Resistances at 20 °C (Ω)

LSA 44.2	Stator L/N	Rotor	Wind. X1,X2	Wind. Z1,Z2	Field	Armat.
VS3	0.046	2.51	0.3	0.5	4.6	0.5
VS45	0.046	2.51	0.3	0.5	4.6	0.5
S7	0.036	2.91	0.21	0.32	4.6	0.5
S75	0.033	2.91	0.21	0.32	4.6	0.5
M95	0.024	3.32	0.17	0.28	4.6	0.5
L12	0.019	3.66	0.16	0.21	4.6	0.5

Field excitation current i_{exc} (A) - 400 V - 50 Hz

« i_{exc} »: excitation current of the exciter field

LSA 44.2	no load	at load
VS3	1	3.6
VS45	1	4.2
S7	1	3.8
S75	1	4.2
M95	1.2	4
L12	1	3.8

• Dedicated single-phase LSA 44.2: 4-pole, SHUNT excitation (60 Hz only)

Resistances at 20 °C (Ω)

LSA 44.2	Stator L/N	Rotor	Field	Armature
VS3	0.0194	2.51	18.4	0.5
VS45	0.0194	2.51	18.4	0.5
S7	0.0140	2.91	18.4	0.5
M95	0.0088	3.32	18.4	0.5

Field excitation current i_{exc} (A) - 240 V - 60 Hz

« i_{exc} »: excitation current of the exciter field

LSA 44.2	no load	at load
VS3	0.44	1.18
VS45	0.44	1.25
S7	0.43	1.2
M95	0.55	1.28

• Table of weights

(values given for information only)

LSA 43.2	Total weight (kg)	Rotor (kg)
S1	220	76
S15	220	76
S25	220	76
S35	240	80
M45	270	90
L65	290	102
L8	330	120

LSA 44.2	Total weight (kg)	Rotor (kg)
VS3	405	140
VS45	405	140
S7	460	165
S75	460	165
M95	515	185
L12	570	210



After operational testing, it is essential to replace all access panels or covers.

LSA 43.2/44.2 - 4 POLES ALTERNATORS

5 - SPARE PARTS

5.1 - First maintenance parts

Emergency repair kits are available as an option.

They contain the following items:

Emergency kit SHUNT	ALT 432 KS 001
AVR R 250	-
Diode bridge assembly	-
Surge suppressor	-

Emergency kit AREP	ALT 432 KS 002
AVR R 450	-
Diode bridge assembly	-
Surge suppressor	-

Single-bearing kit	ALT 432 KB 002
Non drive end bearing	-
«O» ring	-
Preloading (wavy) washer	-

Double-bearing kit	ALT 432 KB 001
Non drive end bearing	-
Drive end bearing	-
«O» ring	-
Preloading (wavy) washer	-

Single-bearing kit	ALT 442 KB 002
Non drive end bearing	-
«O» ring	-
Preloading (wavy) washer	-

Double-bearing kit	ALT 442 KB 001
Non drive end bearing	-
Drive end bearing	-
«O» ring	-
Preloading (wavy) washer	-

5.2 - Technical support service

Our technical support service will be pleased to provide any additional information you may require.

When ordering spare parts, you should indicate the complete machine type, its serial number and the information given on the nameplate.

Address your enquiry to your usual contact.

Part numbers should be identified from the exploded views and their description from the parts list.

Our extensive network of service centres

can dispatch the necessary parts without delay.

To ensure correct operation and the safety of our machines, we recommend the use of original manufacturer spare parts.

In the event of failure to comply with this advice, the manufacturer cannot be held responsible for any damage.



After operational testing, it is essential to replace all access panels or covers.

5.3 - Accessories

• Space heater for use when stopped

The space heater must run as soon as the alternator stops. It is installed at the rear of the machine. Its standard power is 250W with 220V or 250W with 110V on request.



Warning: the power supply is present when the machine has stopped.

• Temperature sensors with thermistors (PTC)

These are thermistor triplets with a positive temperature coefficient installed in the stator winding (1 per phase). There can be a maximum of 2 triplets in the winding (at 2 levels: warning and trip) and 1 or 2 thermistors in the shields.

These sensors must be linked to adapted sensing relays (supplied optionally).

Cold resistance of cold thermistor sensors: 100 to 250 Ω per sensor.

• Connection accessories

- 12-wire machines : coupling (F)
- 3 flexible SHUNTS

LSA 43.2/44.2 - 4 POLES ALTERNATORS

5.4 - Exploded view, parts list and tightening torque

• LSA 43.2 / 44.2 single-bearing

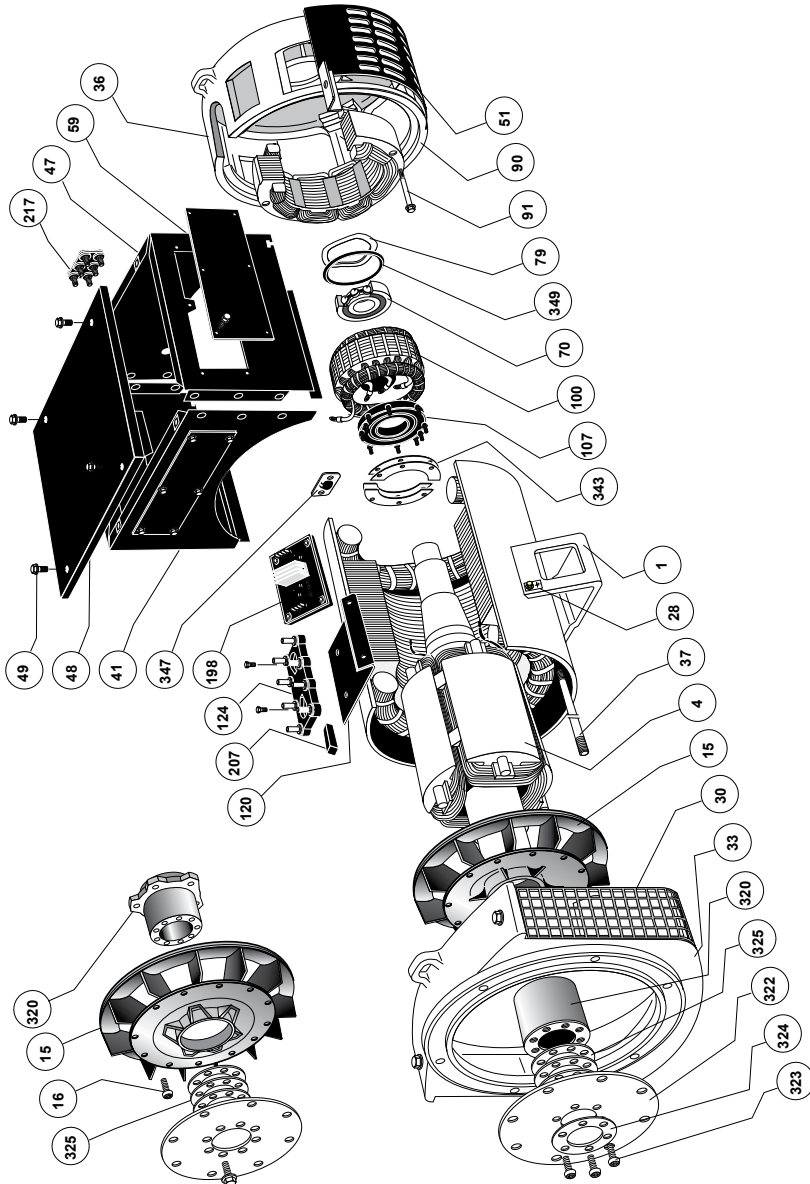

LSA 43.2/44.2 - 4 POLES ALTERNATORS

• LSA 43.2 / 44.2 double-bearing

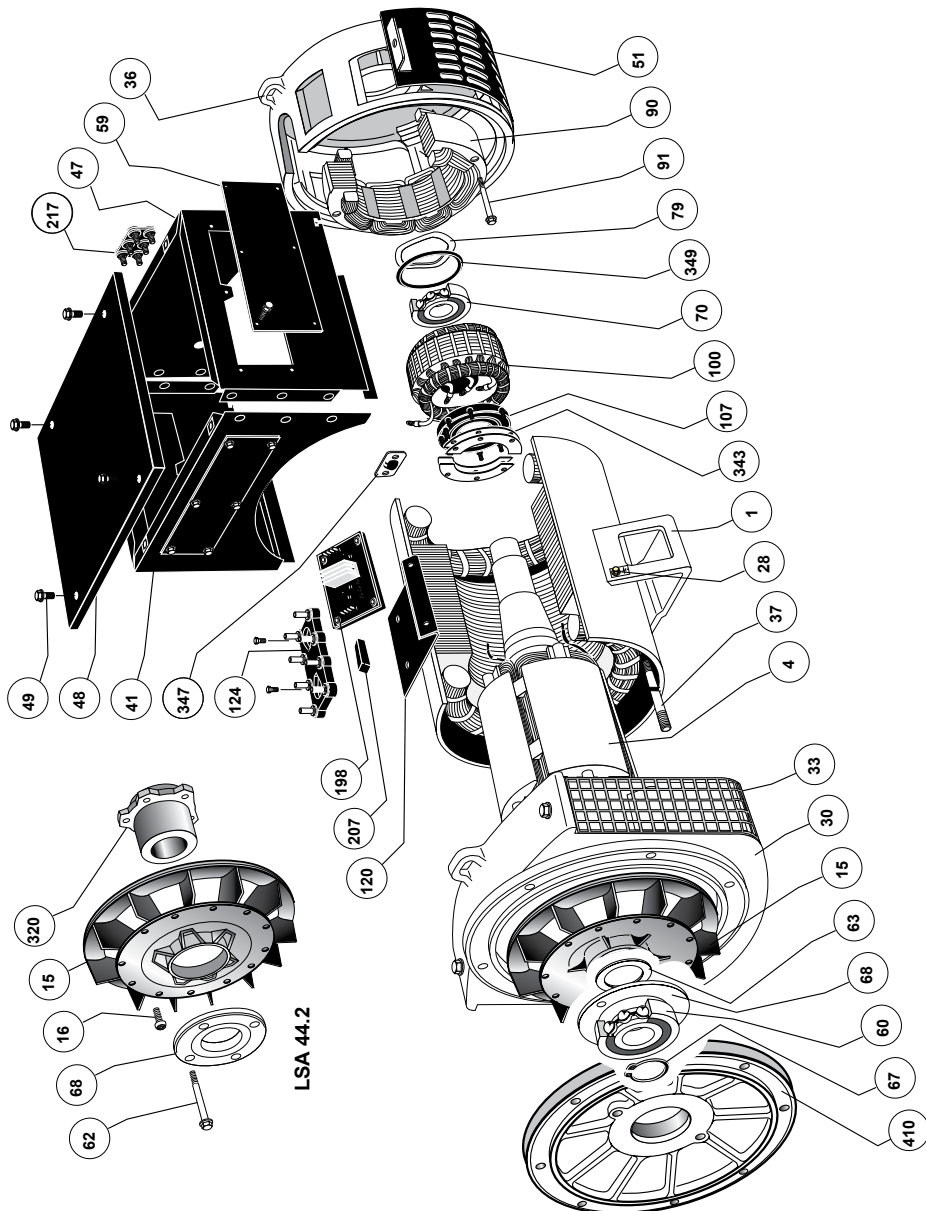

LSA 43.2/44.2 - 4 POLES ALTERNATORS

Ref.	Qty	Description	Screw Ø	Torque N.m	Ref.	Qty	Description	Screw Ø	Torque N.m
1	1	Stator assembly	-	-	70	1	NDE bearing	-	-
4	1	Rotor assembly	-	-	79	1	Preloading wavy washer	-	-
15	1	Fan	M6	5	90	1	Exciter field	-	-
16	6	Fixing screws (44.2 only)	-	-	91	4	Exciter field fixing screw	M6	10
28	1	Earth terminal	M8	26	100	1	Exciter armature	-	-
30	1	DE shield	-	-	107	1	Diode crescent support	-	-
33	1	Air outlet grille	M6	5	120	1	Terminal block support (AREP)	-	-
36	1	Shield on exciter end	-	-	124	1	Terminal block	M10	20
37	4	Tie rod 43.2 Tie rod 44.2	M12 M14	57 90	198	1	Voltage regulator (AVR)	-	-
41	1	Cover front panel	-	-	207	1	AVR damper seal	-	-
47	1	Cover rear panel	-	-	217	1	Terminal block	-	-
48	1	Cover top panel	-	-	320	1	Hub (43.2 L7 & 44.2)	-	-
49	34	Fixing screws	M6	5	322	1	Coupling disc	-	-
51	1	Air intake grille	-	-	323	-	Fixing screws 43.2 Fixing screws 44.2	M12 M16	110 250
59	3	Inspection door	-	-	324	1	Clamping washer (43.2 S1 to L6)	-	-
60	1	DE bearing	-	-	325	-	Spacer shim (43.2 L7 & 44.2 only)	-	-
62	2/4	Bearing retainer fixing screw	-	-	343	1	Diode bridge assembly	M6	5
63	1	Cable gland washer (43.2 only)	-	-	347	1	Surge suppressor	-	-
67	1	Circlips	-	-	349	1	«O» ring	-	-
68	1	Inner bearing retainer	-	-	410	1	End shield	-	-

LSA 43.2/44.2 - 4 POLES ALTERNATORS



Electric Power Generation Division

Declaration of CE compliance and incorporation

This Declaration applies to the generators designed to be incorporated into machines complying with the Machinery Directive Nr 2006/42/CE dated 17 May 2006.

MOTEURS LEROY-SOMER
Boulevard Marcellin Leroy
16015 ANGOULEME
France

MLS HOLICE STLO.SRO
SLADKOVSKÉHO 43
772 04 OLOMOUC
Czech Republic

MOTEURS LEROY-SOMER
1, rue de la Buelle
Boite Postale 1517
45800 St Jean de Braye
France

Declares hereby that the electric generators of the types LSA 36 – 37– 40 – 42.2 – 42.3 – 43.2 – 44.2 – 46.2 – 47.2 – 49.1 – 50.2 – 51.2, as well as their derivatives, manufactured by Leroy Somer or on Leroy Somer's behalf, comply with the following International Standards and Directive :

- EN and IEC 60034 -1 and 60034 -5
- ISO 8528 – 3 " Reciprocating internal combustion engine driven alternating current generating sets.
Part 3. Alternating current generators for generating sets "
- Low Voltage Directive Nr 2006/95/CE dated 12 December 2006.

Furthermore, these generators, designed in compliance with the Machine Directive Nr 2006/42, are therefore able to be incorporated into Electrical Gen-Sets complying with the following International Directives :

- Machinery Directive Nr 2006/42/CE dated 17 May 2006
- EMC Directive Nr 2004/108/CE dated 15 December 2004, as intrinsic levels of emissions and immunity are concerned

WARNING :

The here above mentioned generators should not be commissioned until the corresponding Gen-Sets have been declared in compliance with the Directives Nr 2006/42/CE et 2004/108/CE, as well as with the other relevant Directives.

Leroy Somer undertakes to transmit, in response to a reasoned request by the national authorities, relevant information on the generator.

Technical Managers

P Betge – J.Begué

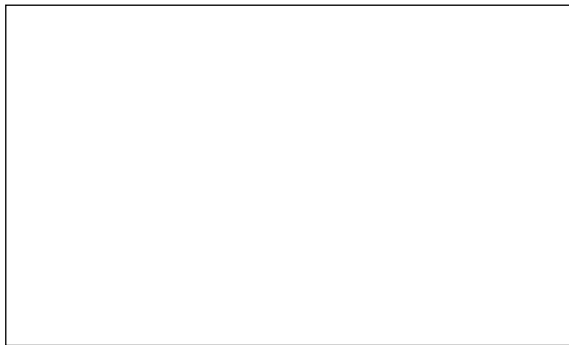

www.leroy-somer.com