

Digitax *ST*

Variable speed drive for servomotors

Technical data guide

General Information

The manufacturer accepts no liability for any consequences resulting from inappropriate, negligent or incorrect installation or adjustment of the optional operating parameters of the equipment or from mismatching the variable speed drive with the motor.

The contents of this guide are believed to be correct at the time of printing. In the interests of a commitment to a policy of continuous development and improvement, the manufacturer reserves the right to change the specification of the product or its performance, or the contents of the guide, without notice.

All rights reserved. No parts of this guide may be reproduced or transmitted in any form or by any means, electrical or mechanical including photocopying, recording or by an information storage or retrieval system, without permission in writing from the publisher.

Drive software version

This product is supplied with the latest version of software. If this product is to be used in a new or existing system with other drives, there may be some differences between their software and the software in this product. These differences may cause this product to function differently. This may also apply to drives returned from a LEROY-SOMER Service Centre.

The software version of the drive can be checked by looking at Pr **11.29** (or Pr **0.50**) and Pr **11.34**. The software version takes the form of zz.yy.xx, where Pr **11.29** displays zz.yy and Pr **11.34** displays xx, i.e. for software version 01.01.00, Pr **11.29** would display 1.01 and Pr **11.34** would display 0.

If there is any doubt, contact LEROY-SOMER.

Environmental statement

LEROY-SOMER is committed to minimising the environmental impacts of its manufacturing operations and of its products throughout their life cycle. To this end, we operate an Environmental Management System (EMS) which is certified to the International Standard ISO 14001.

The electronic variable-speed drives manufactured by LEROY-SOMER have the potential to save energy and (through increased machine/process efficiency) reduce raw material consumption and scrap throughout their long working lifetime. In typical applications, these positive environmental effects far outweigh the negative impacts of product manufacture and end-of-life disposal.

Nevertheless, when the products eventually reach the end of their useful life, they can very easily be dismantled into their major component parts for efficient recycling. Many parts snap together and can be separated without the use of tools, while other parts are secured with conventional screws. Virtually all parts of the product are suitable for recycling.

Product packaging is of good quality and can be re-used. Large products are packed in wooden crates, while smaller products come in strong cardboard cartons which themselves have a high recycled fibre content. If not re-used, these containers can be recycled. Polythene, used on the protective film and bags for wrapping product, can be recycled in the same way. LEROY-Somer's packaging strategy favours easily-recyclable materials of low environmental impact, and regular reviews identify opportunities for improvement.

When preparing to recycle or dispose of any product or packaging, please observe local legislation and best practice.

Contents

1	Introduction	4
2	Product ratings	5
2.1	Model number	5
2.2	Nameplate description	5
2.3	Drive ratings	5
2.4	Typical pulse duty	5
2.5	Continuous rating	9
2.6	Maximum power ratings	9
2.7	Maximum drive losses	10
2.8	Motor cable size and maximum lengths	10
2.9	Braking	10
2.10	AC input ratings	11
2.11	DC drive voltage levels	11
3	Drive dimensions	13
4	I/O Specification	14
4.1	Control terminals	14
4.2	Encoder terminals	17
4.3	Serial communications connections	20
5	EMC filters	21
5.1	External EMC filter rating	21
5.2	Internal and external conducted emissions conformity	21
6	Options	22
7	General data	24
8	Diagnostics	25
8.1	Alarm indications	38
8.2	Status indications	39

1 Introduction

Three different configurations of the Digitax ST servo drive are available:

- Digitax ST Base
- Digitax ST Indexer
- Digitax ST Plus

The Digitax ST Base drive operates in velocity or torque modes and is designed to operate with a centralized motion controller or as a standalone drive.

The Digitax ST Indexer drive performs point-to-point motion profiling including relative, absolute, rotary plus, rotary minus, registration and homing motion. The Digitax ST Indexer will operate as a single standalone system controller. Alternatively, the Digitax ST Indexer can form part of a distributed system where commands are sent over a fieldbus or through digital input/output signals.

The Digitax ST Plus drive offers the option of executing complex movements on a single axis or synchronised movements in relation to a reference axis. It also offers synchronisation and electronic cam functions with management of the virtual master.

All configurations offer a SECURE DISABLE INPUT function . (Refer to the *Installation guide*, paragraph 1)

2 Product ratings

2.1 Model number

Figure 2-1 Model code explanation

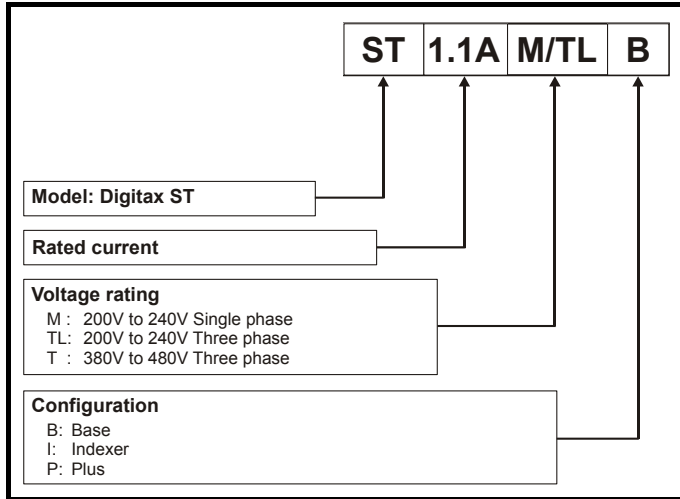

2.2 Nameplate description

Figure 2-2 Typical approvals label

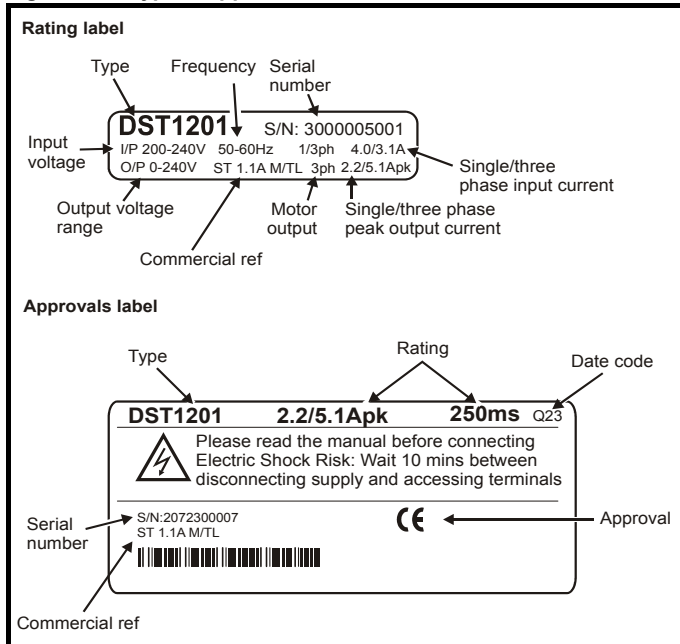

2.3 Drive ratings

The drive rating is limited by numerous systems which protect the power stage hardware. (Rectifier, DC bus, inverter)

These systems come into operation under various extremes of operating conditions. (I.e. ambient, supply imbalance, output power.)

2.3.1 Maximum ratings

Table 2-1 Maximum ratings

Model	No of input phases	Nominal current I_n A		Peak current I_{MAX} A	
		1ph	3ph	1ph	3ph
ST 1.1A M/TL	1 or 3	1.1	1.7	2.2	5.1
ST 2.4A M/TL	1 or 3	2.4	3.8	4.8	11.4
ST 2.9A M/TL	1 or 3	2.9	5.4	5.8	16.2
ST 4.7A M/TL	1 or 3	4.7	7.6	9.4	22.8
ST 1.5A T	3		1.5		4.5
ST 2.7A T	3		2.7		8.1
ST 4.0A T	3		4.0		12.0
ST 5.9 A T	3		5.9		17.7
ST 8.0A T	3		8.0		24.0

The rating information shown in section 2.4 *Typical pulse duty* is based on the limitations of the drive output stage only.

*The ratings are based on the following operating conditions:

- Ambient temperature = 40°C
- Altitude = 1000m
- Not exceeding power ratings stated in Table 2-12 on page 9
- DC bus voltage = 565V for ST X.XA T
- DC bus voltage = 325V for ST X.XA M/TL

The sizing tool should be used to select a drive for a profile or condition that is not given as an example in section 2.4 *Typical pulse duty*.

2.4 Typical pulse duty

The following tables give examples of load profiles that indicate the performance of the drive.

The profiles simulate the drive accelerating from standstill to full speed.

2.4.1 Repetitive profile with defined level of I_{peak}

Figure 2-3 Repetitive profile with defined level of I_{peak}

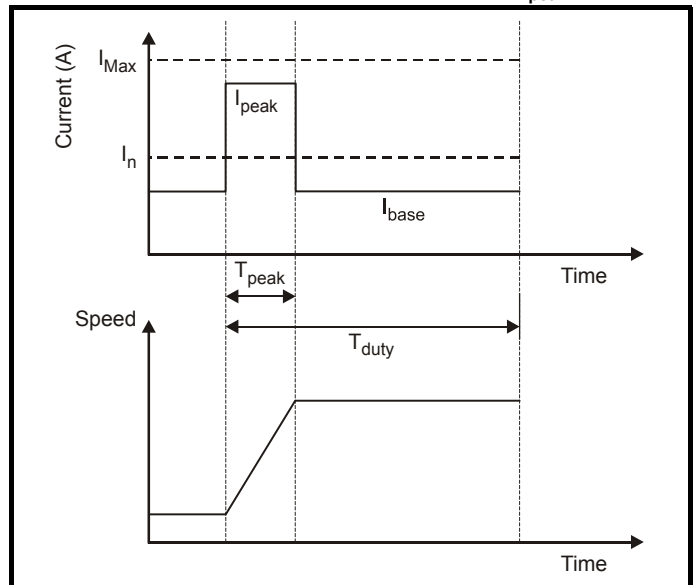

This is a profile with acceleration/deceleration periods where the peak output current from the drive (I_{peak}) is given as a proportion of the nominal current (I_n) for a defined period of time. (T_{peak}).

For example accelerating/decelerating for 10s with a current of 2.0 x I_n .

Introduction	Product ratings	Drive dimensions	I/O Specification	EMC filters	Options	General data	Diagnostics	Index
--------------	------------------------	------------------	-------------------	-------------	---------	--------------	-------------	-------

The ratio between accelerating/decelerating period (T_{peak}) and the total profile period (T_{duty}) is always 1:10.

The profile shows the level of current that can be provided during the running/stopped period when the maximum peak current is used for accelerating/decelerating.

I_{base} is the drive output current during the constant speed segment of the profile.

Table 2-2 Repetitive profile with defined level of I_{peak} at 6kHz switching frequency, $\leq 230V_{ac}$ supply for ST X.XA M/TL and $\leq 400V_{ac}$ supply for ST X.XA T

Model	I_n	Overloads									
		1.5 x I_n for 60s		1.75 x I_n for 40s		2.0 x I_n for 10s		2.5 x I_n for 2s		3.0 x I_n for 0.25s	
		I_{base}	I_{peak}	I_{base}	I_{peak}	I_{base}	I_{peak}	I_{base}	I_{peak}	I_{base}	I_{peak}
A											
ST 1.1A M/TL	1.7	1.7	2.6	1.7	3.0	1.7	3.4	1.7	4.3	1.7	5.1
ST 2.4A M/TL	3.8	3.8	5.7	3.8	6.7	3.8	7.6	3.8	9.5	3.8	11.4
ST 2.9A M/TL	5.4	5.4	8.1	5.4	9.5	5.4	10.8	5.4	13.5	5.4	16.2
ST 4.7A M/TL	7.6	7.6	11.4	7.6	13.3	7.6	15.2	7.6	19.0	7.6	22.8
ST 1.5A T	1.5	1.5	2.3	1.5	2.6	1.5	3.0	1.5	3.8	1.5	4.5
ST 2.7A T	2.7	2.7	4.1	2.7	4.7	2.7	5.4	2.7	6.8	2.7	8.1
ST 4.0A T	4.0	4.0	6.0	4.0	7.0	4.0	8.0	4.0	10.0	4.0	12.0
ST 5.9A T	5.9	5.9	8.9	5.9	10.3	5.9	11.8	5.9	14.8	5.9	17.7
ST 8.0A T	8.0	6.5	12.0	6.8	14.0	8.0	16.0	8.0	20.0	8.0	24.0

Table 2-3 Repetitive profile with defined level of I_{peak} at 8kHz switching frequency, $\leq 230V_{ac}$ supply for ST X.XA M/TL and $\leq 400V_{ac}$ supply for ST X.XA T

Model	I_n	Overloads									
		1.5 x I_n for 60s		1.75 x I_n for 40s		2.0 x I_n for 10s		2.5 x I_n for 2s		3.0 x I_n for 0.25s	
		I_{base}	I_{peak}	I_{base}	I_{peak}	I_{base}	I_{peak}	I_{base}	I_{peak}	I_{base}	I_{peak}
A											
ST 1.1A M/TL	1.7	1.7	2.6	1.7	3.0	1.7	3.4	1.7	4.3	1.7	5.1
ST 2.4A M/TL	3.8	3.8	5.7	3.8	6.7	3.8	7.6	3.8	9.5	3.8	11.4
ST 2.9A M/TL	5.4	5.4	8.1	5.4	9.5	5.4	10.8	5.4	13.5	5.4	16.2
ST 4.7A M/TL	7.6	7.6	11.4	7.6	13.3	7.6	15.2	7.6	19.0	7.6	22.8
ST 1.5A T	1.5	1.5	2.3	1.5	2.6	1.5	3.0	1.5	3.8	1.5	4.5
ST 2.7A T	2.7	2.7	4.1	2.7	4.7	2.7	5.4	2.7	6.8	2.7	8.1
ST 4.0A T	4.0	4.0	6.0	4.0	7.0	4.0	8.0	4.0	10.0	4.0	12.0
ST 5.9A T	5.9	4.4	8.9	4.4	10.3	5.9	11.8	5.9	14.8	5.9	17.7
ST 8.0A T	8.0	1.8	12.0	3.2	14.0	6.9	16.0	7.0	20.0	7.3	24.0

Table 2-4 Repetitive profile with defined level of I_{peak} at 6kHz switching frequency, $\leq 240V_{ac}$ supply for ST X.XA M/TL and $\leq 480V_{ac}$ supply for ST X.XA T

Model	I_n	Overloads									
		1.5 x I_n for 60s		1.75 x I_n for 40s		2.0 x I_n for 10s		2.5 x I_n for 2s		3.0 x I_n for 0.25s	
		I_{base}	I_{peak}	I_{base}	I_{peak}	I_{base}	I_{peak}	I_{base}	I_{peak}	I_{base}	I_{peak}
A											
ST 1.1A M/TL	1.7	1.7	2.6	1.7	3.0	1.7	3.4	1.7	4.3	1.7	5.1
ST 2.4A M/TL	3.8	3.8	5.7	3.8	6.7	3.8	7.6	3.8	9.5	3.8	11.4
ST 2.9A M/TL	5.4	5.4	8.1	5.4	9.5	5.4	10.8	5.4	13.5	5.4	16.2
ST 4.7A M/TL	7.6	7.6	11.4	7.6	13.3	7.6	15.2	7.6	19.0	7.6	22.8
ST 1.5A T	1.5	1.5	2.3	1.5	2.6	1.5	3.0	1.5	3.8	1.5	4.5
ST 2.7A T	2.7	2.7	4.1	2.7	4.7	2.7	5.4	2.7	6.8	2.7	8.1
ST 4.0A T	4.0	4.0	6.0	4.0	7.0	4.0	8.0	4.0	10.0	4.0	12.0
ST 5.9A T	5.9	5.9	8.9	5.9	10.3	5.9	11.8	5.9	14.8	5.9	17.7
ST 8.0A T	8.0	5.5	12.0	5.8	14.0	8.0	16.0	8.0	20.0	8.0	24.0

Table 2-5 Repetitive profile with defined level of I_{peak} at 8kHz switching frequency, $\leq 240V_{ac}$ supply for ST X.XA M/TL and $\leq 480V_{ac}$ supply for ST X.XA T

Model	I_n	Overloads									
		1.5 x I_n for 60s		1.75 x I_n for 40s		2.0 x I_n for 10s		2.5 x I_n for 2s		3.0 x I_n for 0.25s	
		I_{base}	I_{peak}	I_{base}	I_{peak}	I_{base}	I_{peak}	I_{base}	I_{peak}	I_{base}	I_{peak}
A											
ST 1.1A M/TL	1.7	1.7	2.6	1.7	3.0	1.7	3.4	1.7	4.3	1.7	5.1
ST 2.4A M/TL	3.8	3.8	5.7	3.8	6.7	3.8	7.6	3.8	9.5	3.8	11.4
ST 2.9A M/TL	5.4	5.4	8.1	5.4	9.5	5.4	10.8	5.4	13.5	5.4	16.2
ST 4.7A M/TL	7.6	7.6	11.4	7.6	13.3	7.6	15.2	7.6	19.0	7.6	22.8
ST 1.5A T	1.5	1.5	2.3	1.5	2.6	1.5	3.0	1.5	3.8	1.5	4.5
ST 2.7A T	2.7	2.7	4.1	2.7	4.7	2.7	5.4	2.7	6.8	2.7	8.1
ST 4.0A T	4.0	4.0	6.0	4.0	7.0	4.0	8.0	4.0	10.0	4.0	12.0
ST 5.9A T	5.9	3.6	8.9	3.6	10.3	5.9	11.8	5.9	14.8	5.6	17.7
ST 8.0A T	8.0	1.3	12.0	2.5	14.0	5.8	16.0	6.2	20.0	6.1	24.0

2.4.2 Repetitive profile with defined ratio between I_{base} to I_{peak}

Figure 2-4 Repetitive profile with defined ratio between I_{base} to I_{peak}

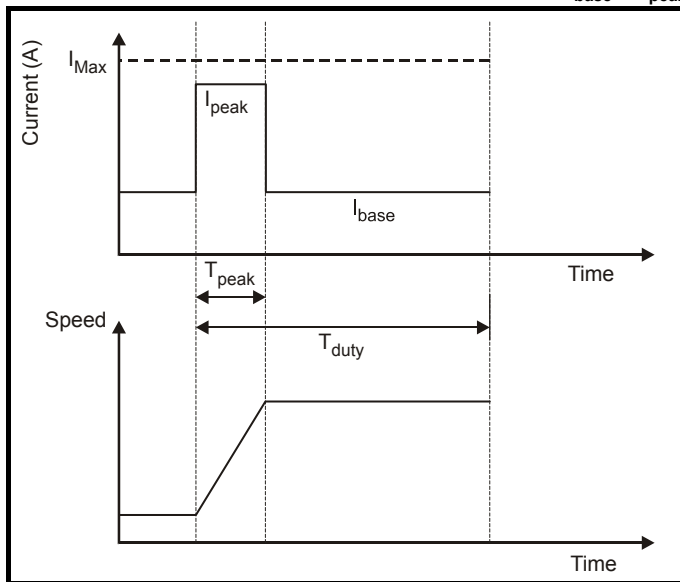

This is a profile with acceleration/deceleration periods where the peak output current from the drive (I_{peak}) is given as a proportion of the base current (I_{base}) for a defined period of time. (T_{peak}).

For example accelerating/decelerating for 10s with a current of 2.0 x I_{base} .

The ratio between accelerating/decelerating period (T_{peak}) and the total profile period (T_{duty}) is always 1:10.

The profile shows the highest I_{base} ratings possible for the given I_{peak}/I_{base} ratio.

Introduction	Product ratings	Drive dimensions	I/O Specification	EMC filters	Options	General data	Diagnostics	Index
--------------	-----------------	------------------	-------------------	-------------	---------	--------------	-------------	-------

Table 2-6 Repetitive profile with defined ratio between I_{base} to I_{peak} at 6kHz switching frequency, $\leq 230V_{ac}$ supply for ST X.XA M/TL and $\leq 400V_{ac}$ supply for ST X.XA T

Model	I_n	Overloads									
		1.5 x I_{base} for 60s		1.75 x I_{base} for 40s		2.0 x I_{base} for 10s		2.5 x I_{base} for 2s		3.0 x I_{base} for 0.25s	
		I_{base}	I_{peak}	I_{base}	I_{peak}	I_{base}	I_{peak}	I_{base}	I_{peak}	I_{base}	I_{peak}
A											
ST 1.1A M/TL	1.7	1.7	2.6	1.7	3.0	1.7	3.4	1.7	4.3	1.7	5.1
ST 2.4A M/TL	3.8	3.8	5.7	3.8	6.7	3.8	7.6	3.8	9.5	3.8	11.4
ST 2.9A M/TL	5.4	5.4	8.1	5.4	9.5	5.4	10.8	5.4	13.5	5.4	16.2
ST 4.7A M/TL	7.6	7.6	11.4	7.6	13.3	7.6	15.2	7.6	19.0	7.6	22.8
ST 1.5A T	1.5	1.5	2.3	1.5	2.6	1.5	3.0	1.5	3.8	1.5	4.5
ST 2.7A T	2.7	2.7	4.1	2.7	4.7	2.7	5.4	2.7	6.8	2.7	8.1
ST 4.0A T	4.0	4.0	6.0	4.0	7.0	4.0	8.0	4.0	10.0	4.0	12.0
ST 5.9A T	5.9	5.9	8.9	5.9	10.3	5.9	11.8	5.9	14.8	5.9	17.7
ST 8.0A T	8.0	7.6	11.4	7.6	13.3	8.0	16.0	8.0	20.0	8.0	24.0

Table 2-7 Repetitive profile with defined ratio between I_{base} to I_{peak} at 8kHz switching frequency, $\leq 230V_{ac}$ supply for ST X.XA M/TL and $\leq 400V_{ac}$ supply for ST X.XA T

Model	I_n	Overloads									
		1.5 x I_{base} for 60s		1.75 x I_{base} for 40s		2.0 x I_{base} for 10s		2.5 x I_{base} for 2s		3.0 x I_{base} for 0.25s	
		I_{base}	I_{peak}	I_{base}	I_{peak}	I_{base}	I_{peak}	I_{base}	I_{peak}	I_{base}	I_{peak}
A											
ST 1.1A M/TL	1.7	1.7	2.6	1.7	3.0	1.7	3.4	1.7	4.3	1.7	5.1
ST 2.4A M/TL	3.8	3.8	5.7	3.8	6.7	3.8	7.6	3.8	9.5	3.8	11.4
ST 2.9A M/TL	5.4	5.4	8.1	5.4	9.5	5.4	10.8	5.4	13.5	5.4	16.2
ST 4.7A M/TL	7.6	7.6	11.4	7.6	13.3	7.6	15.2	7.6	19.0	7.6	22.8
ST 1.5A T	1.5	1.5	2.3	1.5	2.6	1.5	3.0	1.5	3.8	1.5	4.5
ST 2.7A T	2.7	2.7	4.1	2.7	4.7	2.7	5.4	2.7	6.8	2.7	8.1
ST 4.0A T	4.0	4.0	6.0	4.0	7.0	4.0	8.0	4.0	10.0	4.0	12.0
ST 5.9A T	5.9	5.6	8.4	5.6	9.8	5.9	11.8	5.9	14.8	5.9	17.7
ST 8.0A T	8.0	6.0	9.0	6.0	10.5	7.6	15.2	7.6	19.0	7.6	22.8

Table 2-8 Repetitive profile with defined ratio between I_{base} to I_{peak} at 6kHz switching frequency, $\leq 240V_{ac}$ supply for ST X.XA M/TL and $\leq 480V_{ac}$ supply for ST X.XA T

Model	I_n	Overloads									
		1.5 x I_{base} for 60s		1.75 x I_{base} for 40s		2.0 x I_{base} for 10s		2.5 x I_{base} for 2s		3.0 x I_{base} for 0.25s	
		I_{base}	I_{peak}	I_{base}	I_{peak}	I_{base}	I_{peak}	I_{base}	I_{peak}	I_{base}	I_{peak}
A											
ST 1.1A M/TL	1.7	1.7	2.6	1.7	3.0	1.7	3.4	1.7	4.3	1.7	5.1
ST 2.4A M/TL	3.8	3.8	5.7	3.8	6.7	3.8	7.6	3.8	9.5	3.8	11.4
ST 2.9A M/TL	5.4	5.4	8.1	5.4	9.5	5.4	10.8	5.4	13.5	5.4	16.2
ST 4.7A M/TL	7.6	7.6	11.4	7.6	13.3	7.6	15.2	7.6	19.0	7.6	22.8
ST 1.5A T	1.5	1.5	2.3	1.5	2.6	1.5	3.0	1.5	3.8	1.5	4.5
ST 2.7A T	2.7	2.7	4.1	2.7	4.7	2.7	5.4	2.7	6.8	2.7	8.1
ST 4.0A T	4.0	4.0	6.0	4.0	7.0	4.0	8.0	4.0	10.0	4.0	12.0
ST 5.9A T	5.9	5.9	8.9	5.9	10.3	5.9	11.8	5.9	14.8	5.9	17.7
ST 8.0A T	8.0	7.2	10.8	7.2	12.6	8.0	16.0	8.0	20.0	8.0	24.0

Table 2-9 Repetitive profile with defined ratio between I_{base} to I_{peak} at 8kHz switching frequency, $\leq 240V_{ac}$ supply for ST X.XA M/TL and $\leq 480V_{ac}$ supply for ST X.XA T

Model	I_n	Overloads									
		1.5 x I_{base} for 60s		1.75 x I_{base} for 40s		2.0 x I_{base} for 10s		2.5 x I_{base} for 2s		3.0 x I_{base} for 0.25s	
		I_{base}	I_{peak}	I_{base}	I_{peak}	I_{base}	I_{peak}	I_{base}	I_{peak}	I_{base}	I_{peak}
A											
ST 1.1A M/TL	1.7	1.7	2.6	1.7	3.0	1.7	3.4	1.7	4.3	1.7	5.1
ST 2.4A M/TL	3.8	3.8	5.7	3.8	6.7	3.8	7.6	3.8	9.5	3.8	11.4
ST 2.9A M/TL	5.4	5.4	8.1	5.4	9.5	5.4	10.8	5.4	13.5	5.4	16.2
ST 4.7A M/TL	7.6	7.6	11.4	7.6	13.3	7.6	15.2	7.6	19.0	7.6	22.8
ST 1.5A T	1.5	1.5	2.3	1.5	2.6	1.5	3.0	1.5	3.8	1.5	4.5
ST 2.7A T	2.7	2.7	4.1	2.7	4.7	2.7	5.4	2.7	6.8	2.7	8.1
ST 4.0A T	4.0	4.0	6.0	4.0	7.0	4.0	8.0	4.0	10.0	4.0	12.0
ST 5.9A T	5.9	5.3	8.0	5.3	9.3	5.9	11.8	5.9	14.8	5.9	17.7
ST 8.0A T	8.0	5.6	8.4	5.6	9.8	6.4	12.8	6.8	17.0	6.8	20.4

2.5 Continuous rating

Table 2-10 Continuous rating with no overload, $\leq 230V_{ac}$ supply for ST X.XA M/TL and $\leq 400V_{ac}$ supply for ST X.XA T

Model	I_n	6kHz		8kHz		12kHz	
		I_{cont} at 0Hz	I_{cont} at 150Hz	I_{cont} at 0Hz	I_{cont} at 150Hz	I_{cont} at 0Hz	I_{cont} at 150Hz
		A					
ST 1.1A M/TL	1.7	1.7					
ST 2.4A M/TL	3.8	3.8					
ST 2.9A M/TL	5.4	5.4					
ST 4.7A M/TL	7.6	7.6					
ST 1.5A T	1.5	1.5					
ST 2.7A T	2.7	2.7					
ST 4.0A T	4.0	4.0					3.8
ST 5.9A T	5.9	5.9		5.0	5.9	3.1	
ST 8.0A T	8.0	8.0	6.0	8.0	4.6	5.8	2.8

Table 2-11 Continuous rating with no overload, $\leq 240V_{ac}$ supply for ST X.XA M/TL and $\leq 480V_{ac}$ supply for ST X.XA T

Model	I_n	6kHz		8kHz		12kHz	
		I_{cont} at 0Hz	I_{cont} at 150Hz	I_{cont} at 0Hz	I_{cont} at 150Hz	I_{cont} at 0Hz	I_{cont} at 150Hz
		A					
ST 1.1A M/TL	1.7	1.7					
ST 2.4A M/TL	3.8	3.8					
ST 2.9A M/TL	5.4	5.4					
ST 4.7A M/TL	7.6	7.6					
ST 1.5A T	1.5	1.5					
ST 2.7A T	2.7	2.7					
ST 4.0A T	4.0	4.0					3.0
ST 5.9A T	5.9	5.9	5.4	5.9	4.2	4.7	2.3
ST 8.0A T	8.0	8.0	5.0	7.3	3.8	4.7	2.2

NOTE

The power available from a rectifier may limit these figures.

The drive will automatically reduce the output switching frequency so that the highest possible output current can be supported without a thermal trip.

This allows the drive to support the highest possible current at standstill while operating at a higher switching frequency under normal running conditions.

This feature can be disabled using drive Pr 5.35, see the *Advanced User Guide* for further details.

2.6 Maximum power ratings

For the models shown, the protection systems limit the output rating of the drive.

The ratings are based on the following operating conditions:

- Ambient temperature = 40°C
- Altitude = 1000m

Table 2-12 Maximum rectifier power, $\leq 230V_{ac}$ supply for ST X.XA M/TL and $\leq 400V_{ac}$ supply for ST X.XA T

Model	No. of Input phases	Power at supply voltage	
		Without line reactor	With line reactor
		kW	kW
ST 1.1A M/TL	1	0.329	
ST 2.4A M/TL	1	0.714	
ST 2.9A M/TL	1	0.864	
ST 4.7A M/TL	1	1.391	
ST 1.1A M/TL	3	0.51	
ST 2.4A M/TL	3	1.13	
ST 2.9A M/TL	3	1.61	
ST 4.7A M/TL	3	1.77	1.98
ST 1.5A T	3	0.77	
ST 2.7A T	3	1.36	
ST 4.0A T	3	2.04	
ST 5.9A T	3	2.93	2.99
ST 8.0A T	3	2.77	3.05

Introduction	Product ratings	Drive dimensions	I/O Specification	EMC filters	Options	General data	Diagnostics	Index
--------------	------------------------	------------------	-------------------	-------------	---------	--------------	-------------	-------

Table 2-13 Maximum rectifier power, ≤240Vac supply for ST X.XA M/TL and ≤480Vac supply for ST X.XA T

Model	No. of Input phases	Power at supply voltage	
		Without line reactor	With line reactor
		kW	kW
ST 1.1A M/TL	1	0.394	
ST 2.4A M/TL	1	0.857	
ST 2.9A M/TL	1	1.03	
ST 4.7A M/TL	1	1.66	
ST 1.1A M/TL	3	0.609	
ST 2.4A M/TL	3	1.35	
ST 2.9A M/TL	3	1.92	
ST 4.7A M/TL	3	2.12	2.38
ST 1.5A T	3	0.924	
ST 2.7A T	3	1.63	
ST 4.0A T	3	2.44	
ST 5.9A T	3	3.51	3.58
ST 8.0A T	3	3.32	3.65

The sizing tool should be used to select a drive for conditions not given in this manual.

2.6.1 DC bus design

Parallel connections

The power limit of the rectifier must be adhered to for all combinations of drives in parallel. In addition to this, the ST 2.9A M/TL, ST 4.7A M/TL, ST 4.0A T, ST 5.9A T and ST 8.0A T need to have an input impedance of 2%.

There are many possible combinations for paralleling drives through the DC bus connections. Table 2-14 gives details of the internal capacitance for each drive and the additional capacitance which can be powered from the drive. The capacitance must incorporate its own soft-start circuit. All Digitax ST drives incorporate this feature.

Table 2-14 DC bus data

Model	Internal DC bus capacitance	Additional capacitance which can be connected
	μF	μF
ST 1.1A M/TL	440	2640
ST 2.4A M/TL	880	3960
ST 2.9A M/TL	880	3080
ST 4.7A M/TL	1320	2640
ST 1.5A T	220	440
ST 2.7A T	220	1100
ST 4.0A T	220	1320
ST 5.9A T	220	1320
ST 8.0A T	220	1320

2.7 Maximum drive losses

Table 2-15 Maximum drive losses

Model	6kHz	8kHz	12kHz
	W	W	W
ST 1.1A M/TL	64	65	69
ST 2.4A M/TL	79	82	88
ST 2.9A M/TL	102	109	122
ST 4.7A M/TL	107	110	118
ST 1.5A T	79	87	101
ST 2.7A T	77	81	90
ST 4.0A T	124	142	177
ST 5.9A T	127	143	175
ST 8.0A T	150	169	207

2.8 Motor cable size and maximum lengths

Table 2-16 Motor cable size and maximum lengths

Model	Output cable	Output cable	6kHz	8kHz	12kHz
	mm ²	AWG	m	m	m
ST 1.1A M/TL	0.75	24	50		
ST 2.4A M/TL		22			
ST 2.9A M/TL		20			
ST 4.7A M/TL		18			
ST 1.5A T		24			
ST 2.7A T		22			
ST 4.0A T		20			
ST 5.9A T		18			
ST 8.0A T		18			

Use 105°C (221°F) (UL 60/75°C temp rise) PVC-insulated cable with copper conductors having a suitable voltage rating, for the following power connections:

- AC supply to external EMC filter (when used)
- AC supply (or external EMC filter) to drive
- Drive to motor
- Drive to braking resistor
- When operating in ambient >45°C UL 75°C cable should be used.

Cable sizes are given for guidance only and may be changed depending on the application and the method of installation of the cables.

The mounting and grouping of cables affect their current capacity, in some cases a larger cable is required to avoid excessive temperature or voltage drop.

Input cable sizes should generally be regarded as a minimum, since they have been selected for co-ordination with the recommended fuses.

Output cable sizes assume that the maximum motor current matches that of the drive.

Where a motor of reduced rating is used the cable rating may be chosen to match that of the motor.

To ensure that the motor and cable are protected against overload, the drive must be programmed with the correct motor rated current.

The terminals are designed for a maximum cable size of 4.0mm² (minimum 26 AWG).

Where more than one cable per terminal is used the combined diameters should not exceed the maximum.

The terminals are suitable for both solid and stranded wires.

2.9 Braking

Table 2-17 Internal braking resistor data

Parameter		
Part number	1299-0001-00	
DC resistance at 25°C	70Ω	
Peak instantaneous power over 1ms at nominal resistance	200V	400V
	2.2kW	8.7kW
Average power over 60s	50W	

Introduction	Product ratings	Drive dimensions	I/O Specification	EMC filters	Options	General data	Diagnostics	Index
--------------	------------------------	------------------	-------------------	-------------	---------	--------------	-------------	-------

Table 2-18 Minimum resistance and power ratings

Model	Minimum resistance* Ω	Peak power rating kW	Continuous power rating kW	Average power for 0.25s kW
ST 1.1A M/TL	23	6.6	0.5	1.6
ST 2.4A M/TL			1.2	3.5
ST 2.9A M/TL			1.6	4.9
ST 4.7A M/TL			2.3	7.0
ST 1.5A T	111	5.5	0.8	2.3
ST 2.7A T			1.4	4.1
ST 4.0A T			2.0	6.1
ST 5.9A T	28	21.7	3.0	9.0
ST 8.0A T			4.1	12.2

* Resistor tolerance: ±10%

2.10 AC input ratings

Table 2-19 Drive input ratings

Model	No of input phases	Typical input current	Maximum continuous input current
		A	A
ST 1.1A M/TL	1		3.1
ST 2.4A M/TL	1		6.4
ST 2.9A M/TL	1		8.6
ST 4.7A M/TL	1		11.8
ST 1.1A M/TL	3	3.1	3.5
ST 2.4A M/TL	3	6.4	7.3
ST 2.9A M/TL	3	8.6	9.4
ST 4.7A M/TL	3	11.8	13.4
ST 1.5A T	3	2.6	2.8
ST 2.7A T	3	4.2	4.3
ST 4.0A T	3	5.9	6.0
ST 5.9A T	3	7.9	8.0
ST 8.0A T	3	9.9	9.9

2.10.1 Supply requirements

Table 2-20 Supply requirements

Model	Voltage	Frequency range
ST X.XA M/TL	200V to 240V ±10% single phase	48Hz to 65Hz
ST X.XA M/TL	200V to 240V ±10% three phase*	48Hz to 65Hz
ST X.XA T	380V to 480V ±10% three phase*	48Hz to 65Hz

*Maximum supply in-balance: 2% negative phase sequence (equivalent to 3% voltage in-balance between phases).

For UL compliance only, the maximum supply symmetrical fault current must be limited to 100kA.

2.10.2 Line reactors

Input line reactors reduce the risk of damage to the drive resulting from poor phase balance or severe disturbances on the supply network.

Where line reactors are to be used, reactance values of approximately 2% are recommended. Higher values may be used if necessary, but may result in a loss of drive output (reduced torque at high speed) because of the voltage drop.

For all drive ratings, 2% line reactors permit drives to be used with a supply imbalance of up to 3.5% negative phase sequence (equivalent to 5% voltage imbalance between phases).

Severe disturbances may be caused by the following factors, for example:

- Power factor correction equipment connected close to the drive

- Large DC drives having no or inadequate line reactors connected to the supply
- Direct-on-line started motor(s) connected to the supply such that when any of these motors are started, the voltage dip exceeds 20%

Such disturbances may cause excessive peak currents to flow in the input power circuit of the drive. This may cause nuisance tripping, or in extreme cases, failure of the drive.

Drives of low power rating may also be susceptible to disturbance when connected to supplies with a high rated capacity.

When required, each drive must have its own reactor(s). Three individual reactors or a single three-phase reactor should be used.

Reactor current ratings

Continuous current:

Not less than the continuous input current rating of the drive

Repetitive peak current:

Not less than three times the continuous input current rating of the drive

2.11 DC drive voltage levels

2.11.1 Control 24Vdc supply

The 24Vdc input has three main functions:

- It can be used as a back-up power supply to keep the control circuits of the drive powered up when the line power supply is removed. This allows any fieldbus modules or serial communications to continue to operate.
- It can be used to supplement the drive's own internal 24V when multiple SM-I/O Plus modules are being used and the current drawn by these modules is greater than the drive can supply. (If too much current is drawn from the drive, the drive will initiate a 'PS.24V' trip)
- It can be used to commission the drive when line power supply voltages are not available, as the display operates correctly. However, the drive will be in the UV trip state unless either line power supply is reapplied or low voltage DC operation is enabled, therefore diagnostics may not be possible. (Power down save parameters are not saved when using the 24V back-up power supply input.)

The working voltage range of the 24V power supply is shown in Table 2-21.

Table 2-21 Control supply voltage levels

Condition	Value
Maximum continuous operating voltage	30.0V
Minimum continuous operating voltage	19.2V
Nominal operating voltage	24.0V
Minimum start up voltage	21.6V
Maximum power supply requirement at 24V	60W
Recommended fuse	3 A, 50Vdc

Minimum and maximum voltage values include ripple and noise. Ripple and noise values must not exceed 5%.

2.11.2 Low voltage DC operation

The drive can be operated from low voltage DC supplies, nominally 24Vdc (control) and 48Vdc (power). The low voltage DC power operating mode is designed either, to allow for motor operation in an emergency back-up situation following failure of the AC supply, for example in robotic arm applications; or to limit the speed of a servo motor during set-up of equipment, for example a robot cell.

The working voltage range of the low voltage DC power supply is shown in Table 2-22.

Table 2-22 Low voltage DC levels

Condition	Value
Minimum continuous operating voltage	36V
Minimum start up voltage	40V
Nominal continuous operating voltage	48V to 72V
Maximum braking IGBT turn on voltage	63V to 95V
Maximum over voltage trip threshold	69V to 104V

2.11.3 High voltage DC levels

Table 2-23 High voltage DC levels

Condition	ST X.XA M/TL	ST X.XA T
	V	V
Undervoltage trip level	175	330
Undervoltage reset level*	215	425
Overvoltage trip level	415	830
Braking level	390	780
Maximum continuous voltage level for 15s	400	800

* These are the absolute minimum DC voltages that the drive can be supplied with. If the drive is not supplied with at least this voltage, it will not reset out of a UV trip at power-up.

3 Drive dimensions



Enclosure
 The drive is intended to be mounted in an enclosure which prevents access except by trained and authorized personnel, and which prevents the ingress of contamination. It is designed for use in an environment classified as pollution degree 2 in accordance with IEC 60664-1. This means that only dry, non-conducting contamination is acceptable.

The drive complies with the requirements of IP20 as standard.

Figure 3-1 Dimensions

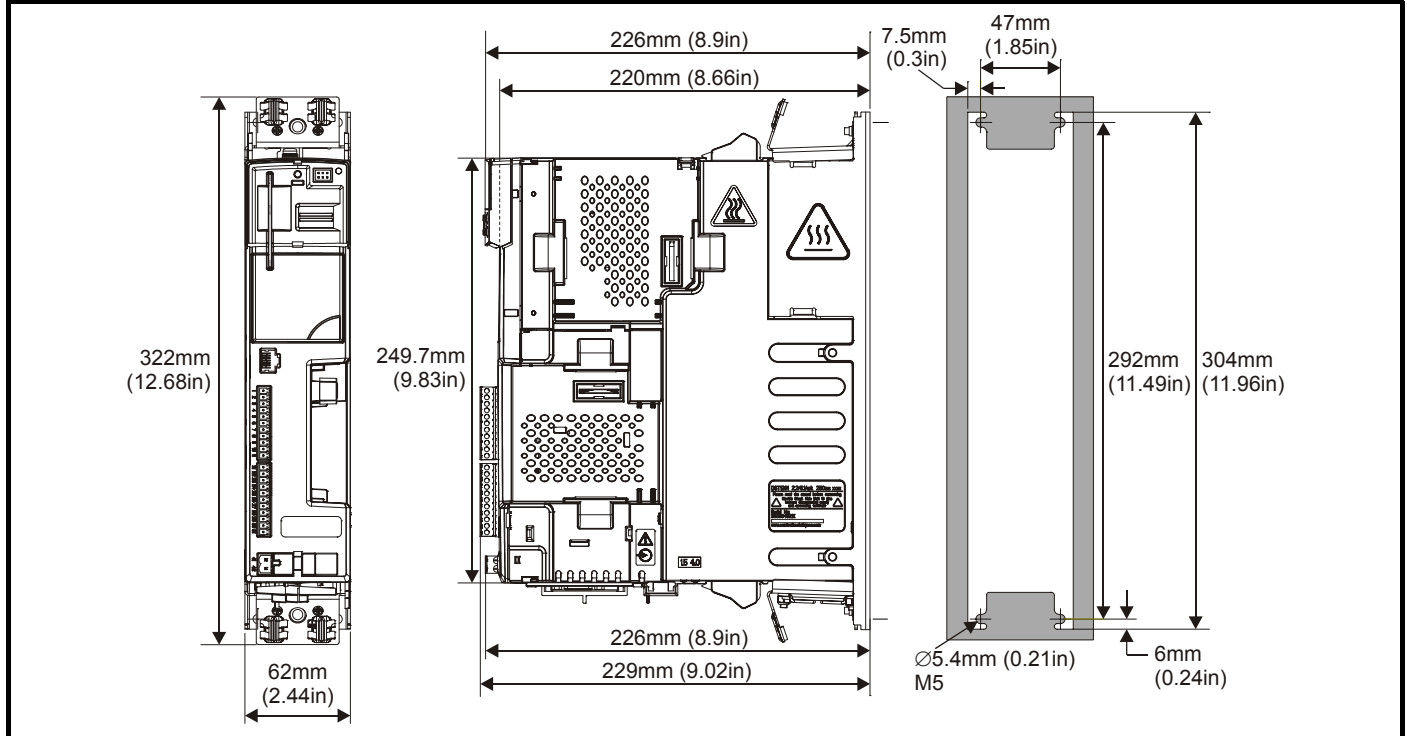
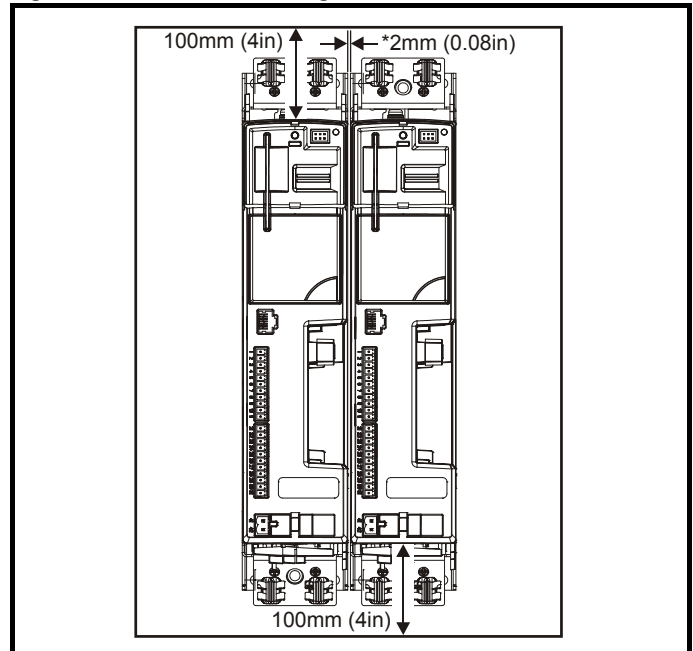

Table 3-1 Torque settings

Terminals	Torque setting*
Power terminals	1.0 N m (12.1 lb in)
Control terminals	0.2 N m (1.7 lb in)
Status relay terminals	0.5 N m (4.5 lb in)
Ground terminals	4 N m (35 lb in)

*Torque tolerance = 10%

Figure 3-2 Minimum mounting clearances



*2mm clearance between drives to allow for mechanical tolerance.

4 I/O Specification

4.1 Control terminals

Figure 4-1 Default terminal functions

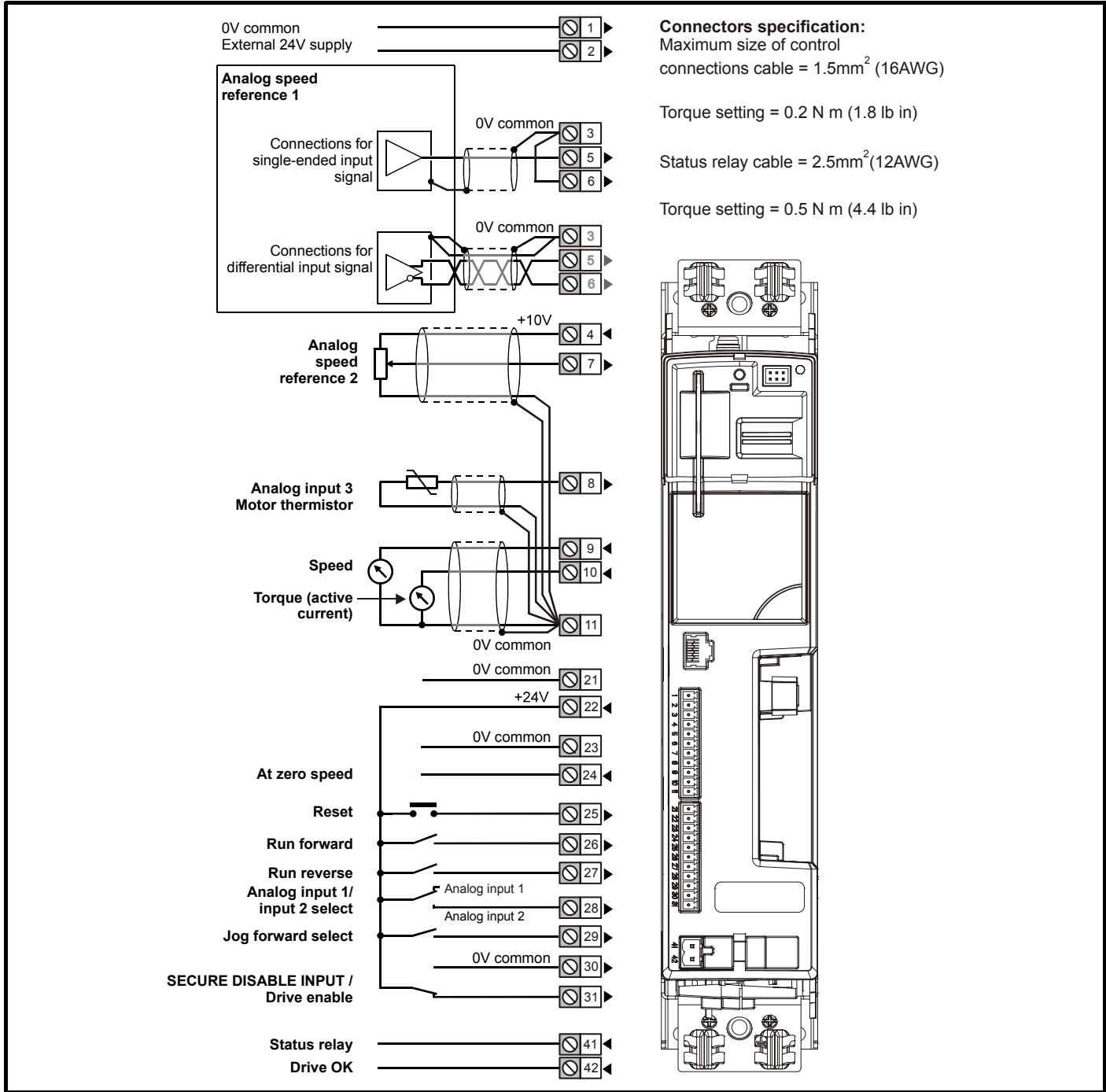

1	0V common
Function	Common connection for all external devices

2	+24V external input
Function	To supply the control circuit without providing a supply to the power stage
Nominal voltage	+24.0Vdc
Minimum continuous operating voltage	+19.2Vdc
Maximum continuous operating voltage	+30.0Vdc
Minimum start-up voltage	21.6Vdc
Recommended power supply	60W 24Vdc nominal
Recommended fuse	3A, 50Vdc

3	0V common
Function	Common connection for all external devices

4	+10V user output
Function	Supply for external analog devices
Voltage tolerance	±1%
Maximum output current	10mA
Protection	Current limit and trip @ 30mA

	Precision reference Analog input 1
5	Non-inverting input
6	Inverting input
Default function	Frequency/speed reference
Type of input	Bipolar differential analog (For single-ended use, connect terminal 6 to terminal 3)
Full scale voltage range	±9.8V ±1%
Absolute maximum voltage range	±36V relative to 0V
Working common mode voltage range	±13V relative to 0V
Input resistance	100kΩ ±1%
Resolution	16-bit plus sign (as speed reference)
Monotonic	Yes (including 0V)
Dead band	None (including 0V)
Jumps	None (including 0V)
Maximum offset	700μV
Maximum non linearity	0.3% of input
Maximum gain asymmetry	0.5%
Input filter bandwidth single pole	~1kHz
Sampling period	250μs with destinations as Pr 1.36, Pr 1.37 or Pr 3.22.

7	Analog input 2
Default function	Frequency/speed reference
Type of input	Bipolar single-ended analog voltage or unipolar current
Mode controlled by...	Pr 7.11
Operating in Voltage mode	
Full scale voltage range	±9.8V ±3%
Maximum offset	±30mV
Absolute maximum voltage range	±36V relative to 0V
Input resistance	>100kΩ
Operating in current mode	
Current ranges	0 to 20mA ±5%, 20 to 0mA ±5%, 4 to 20mA ±5%, 20 to 4mA ±5%
Maximum offset	250μA
Absolute maximum voltage (reverse bias)	-36V max
Absolute maximum current	+70mA
Equivalent input resistance	≤200Ω at 20mA
Resolution	10 bit + sign
Sample period	250μs when configured as voltage input with destinations as Pr 1.36, Pr 1.37, Pr 3.22 or Pr 4.08.

8	Analog input 3
Default function	Motor thermistor input (PTC)
Type of input	Bipolar single-ended analog voltage, unipolar current or motor thermistor input
Mode controlled by...	Pr 7.15
Operating in Voltage mode (default)	
Voltage range	±9.8V ±3%
Maximum offset	±30mV
Absolute maximum voltage range	±36V relative to 0V
Input resistance	>100kΩ
Operating in current mode	
Current ranges	0 to 20mA ±5%, 20 to 0mA ±5%, 4 to 20mA ±5%, 20 to 4mA ±5%
Maximum offset	250μA
Absolute maximum voltage (reverse bias)	-36V max
Absolute maximum current	+70mA
Equivalent input resistance	≤200Ω at 20mA
Operating in thermistor input mode	
Internal pull-up voltage	<5V
Trip threshold resistance	3.3kΩ ±10%
Reset resistance	1.8kΩ ±10%
Short-circuit detection resistance	50Ω ±30%
Resolution	10 bit + sign
Sample period	250μs when configured as voltage input with destinations as Pr 1.36, Pr 1.37, Pr 3.22 or Pr 4.08.

T8 analog input 3 has a parallel connection to terminal 15 of the drive input encoder connector.

9	Analog output 1
10	Analog output 2
Terminal 9 default function	SPEED output signal
Terminal 10 default function	Motor active current
Type of output	Bipolar single-ended analog voltage or unipolar single ended current
Mode controlled by...	Pr 7.21 and Pr 7.24
Operating in Voltage mode (default)	
Voltage range	±9.6V ±5%
Maximum offset	100mV
Maximum output current	±10mA
Load resistance	1kΩ min
Protection	35mA max. Short circuit protection
Operating in current mode	
Current ranges	0 to 20mA ±10% 4 to 20mA ±10%
Maximum offset	600μA
Maximum open circuit voltage	+15V
Maximum load resistance	500Ω
Resolution	10-bit (plus sign in voltage mode)
Update period	250μs when configured as a high speed output with sources as Pr 4.02, Pr 4.17, Pr 3.02 or Pr 5.03. 4ms when configured as any other type of output or with all other sources.

11	0V common
Function	Common connection for all external devices

21	0V common
Function	Common connection for all external devices

22	+24V user output (selectable)
Terminal 22 default function	+24V user output
Programmability	Can be switched on or off to act as a fourth digital output (positive logic only) by setting the source Pr 8.28 and source invert Pr 8.18
Nominal output current	200mA (including all digital I/O)
Maximum output current	240mA (including all digital I/O)
Protection	Current limit and trip

23	0V common
Function	Common connection for all external devices

24	Digital I/O 1
25	Digital I/O 2
26	Digital I/O 3
Terminal 24 default function	AT ZERO SPEED output
Terminal 25 default function	DRIVE RESET input
Terminal 26 default function	RUN FORWARD input
Type	Positive or negative logic digital inputs, positive or negative logic push-pull outputs or open collector outputs
Input / output mode controlled by...	Pr 8.31, Pr 8.32 and Pr 8.33
Operating as an input	
Logic mode controlled by...	Pr 8.29
Absolute maximum applied voltage range	±30V
Impedance	6kΩ
Input thresholds	10.0V ±0.8V
Operating as an output	
Open collector outputs selected	Pr 8.30
Nominal maximum output current	200mA (total including terminal 22)
Maximum output current	240mA (total including terminal 22)
Nominal working voltage range	0V to +24V
Sample / Update period	250μs when configured as an input with destinations as Pr 6.35 or Pr 6.36. 600μs when configured as an input with destination as Pr 6.29. 4ms in all other cases.

27	Digital Input 4
28	Digital Input 5
29	Digital Input 6
Terminal 27 default function	RUN REVERSE input
Terminal 28 default function	Analog INPUT 1 / INPUT 2 select
Terminal 29 default function	JOG SELECT input
Type	Positive or negative logic digital inputs
Logic mode controlled by...	Pr 8.29
Voltage range	0V to +24V
Absolute maximum applied voltage range	±30V
Impedance	6kΩ
Input thresholds	10.0V ±0.8V
Sample / Update period	250μs with destinations as Pr 6.35 or Pr 6.36. 600μs with destination as Pr 6.29. 4ms in all other cases.

30	0V common
Function	Common connection for all external devices

31	SECURE DISABLE INPUT/drive enable
Type	Positive logic only digital input
Voltage range	0V to +24V
Absolute maximum applied voltage	±30V
Thresholds	15.5V ±2.5V
Response time	Nominal: 8ms Maximum: 20ms
<p>The drive enable terminal (T31) provides a SECURE DISABLE INPUT function. The SECURE DISABLE INPUT function meets the requirements of EN954-1 category 3 for the prevention of unexpected starting of the drive. It may be used in a safety-related application in preventing the drive from generating torque in the motor to a high level of integrity.</p>	

41	Relay contacts
42	
Default function	Drive OK indicator
Contact voltage rating	240Vac, Installation over-voltage category II
Contact maximum current rating	2A AC 240V 4A DC 30V resistive load 0.5A DC 30V inductive load (L/R = 40ms)
Contact minimum recommended rating	12V 100mA
Contact type	Normally open
Default contact condition	Closed when power applied and drive OK
Update period	4ms



A fuse or other over-current protection should be installed to the relay circuit.

WARNING

4.2 Encoder terminals

Figure 4-2 Location of encoder connectors on underside of drive

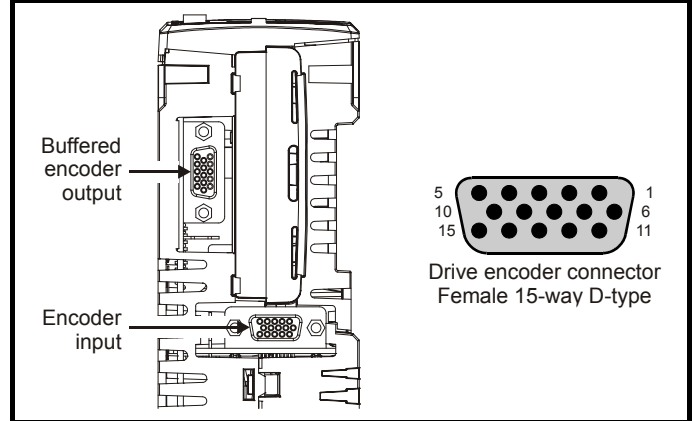

4.2.1 Encoder In connections

Table 4-1 Encoder types

Setting of Pr 3.38	Description
Ab (0)	Quadrature incremental encoder with or without marker pulse
Fd (1)	Incremental encoder with frequency pulses and direction, with or without marker pulse
Fr (2)	Incremental encoder with forward pulses and reverse pulses, with or without marker pulse
Ab.SErVO (3)	Quadrature incremental encoder with UVW commutation signals, with or without marker pulse Encoder with UVW commutation signals only (Pr 3.34 set to zero)*
Fd.SErVO (4)	Incremental encoder with frequency pulses and direction with commutation signals**, with or without marker pulse
Fr.SErVO (5)	Incremental encoder with forward pulses and reverse pulses with commutation signals**, with or without marker pulse
SC (6)	SinCos encoder without serial communications
SC.HiPEr (7)	Absolute SinCos encoder with HiperFace serial communications protocol (Stegmann)
EndAt (8)	Absolute EndAt serial communications encoder (Heidenhain)
SC.EndAt (9)	Absolute SinCos encoder with EnDat serial communications protocol (Heidenhain)
SSI (10)	Absolute SSI only encoder
SC.SSI (11)	Absolute SinCos encoder with SSI

* This feedback device provides very low resolution feedback and should not be used for applications requiring a high level of performance

** The U, V & W commutation signals are required with an incremental type encoder when used with a servo motor. The UVW commutation signals are used to define the motor position during the first 120° electrical rotation after the drive is powered-up or the encoder is initialized.

Introduction	Product ratings	Drive dimensions	I/O Specification	EMC filters	Options	General data	Diagnostics	Index
--------------	-----------------	------------------	--------------------------	-------------	---------	--------------	-------------	-------

Table 4-2 Encoder In connector details

Term.	Setting of Pr 3.38												
	Ab (0)	Fd (1)	Fr (2)	Ab.SErVO (3)	Fd.SErVO (4)	Fr.SErVO (5)	SC (6)	SC.HiPEr (7)	EndAt (8)	SC.EndAt (9)	SSI (10)	SC.SSI (11)	
1	A	F	F	A	F	F		Cos		Cos		Cos	
2	A\	F\	F\	A\	F\	F\		Cosref		Cosref		Cosref	
3	B	D	R	B	D	R		Sin		Sin		Sin	
4	B\	D\	R\	B\	D\	R\		Sinref		Sinref		Sinref	
5	Z*							Encoder input - Data (input/output)					
6	Z*							Encoder input - Data\ (input/output)					
7							U						
8							U\						
9							V						
10							V\						
11							W						
12							W\						
13	+V**												
14	0V common												
15	th												

* Marker pulse is optional

** The encoder supply is selectable through parameter configuration to 5Vdc, 8Vdc and 15Vdc

NOTE

SSI encoders typically have maximum baud rate of 500kbaud. When a SSI only encoder is used for speed feedback with a servo motor, a large speed feedback filter (Pr 3.42) is required due to the time taken for the position information to be transferred from the encoder into the drive. The addition of this filter means that SSI only encoders are not suitable for speed feedback in dynamic or high-speed applications.

Specifications

Feedback device connections

Ab, Fd, Fr, Ab.SErVO, Fd.SErVO and Fr.SErVO encoders

1	Channel A, Frequency or Forward inputs
2	Channel A\, Frequency\ or Forward\ inputs
3	Channel B, Direction or Reverse inputs
4	Channel B\, Direction\ or Reverse\ inputs
Type	EIA 485 differential receivers
Maximum input frequency	500kHz
Line loading	<2 unit loads
Line termination components	120Ω (switchable)
Working common mode range	+12V to -7V
Absolute maximum applied voltage relative to 0V	±25V
Absolute maximum applied differential voltage	±25V

5	Marker pulse channel Z
6	Marker pulse channel Z\
7	Phase channel U
8	Phase channel U\
9	Phase channel V
10	Phase channel V\
11	Phase channel W
12	Phase channel W\
Type	EIA 485 differential receivers
Maximum input frequency	512kHz
Line loading	32 unit loads (for terminals 5 and 6) 1 unit load (for terminals 7 to 12)
Line termination components	120Ω (switchable for terminals 5 and 6, always in circuit for terminals 7 to 12)
Working common mode range	+12V to -7V
Absolute maximum applied voltage relative to 0V	+14V to -9V
Absolute maximum applied differential voltage	+14V to -9V

SC, SC.HiPEr, EndAt, SC.EndAt, SSI and SC.SSI encoders

1	Channel Cos*
2	Channel Cosref*
3	Channel Sin*
4	Channel Sinref*

Type	Differential voltage
Maximum Signal level	1.25V peak to peak (sin with regard to sinref and cos with regard to cosref)
Maximum input frequency	See Table 4-3
Maximum applied differential voltage and common mode voltage range	±4V

For the SinCos encoder to be compatible with Digitax ST, the output signals from the encoder must be a 1V peak to peak differential voltage (across Sin to Sinref and Cos to Cosref).

The majority of encoders have a DC offset on all signals. A number of encoder manufactures typically have a 2.5Vdc offset. The Sinref and Cosref are a flat DC level at 2.5Vdc and the Cos and Sin signals have a 1V peak to peak waveform biased at 2.5Vdc.

Encoders are available which have a 1V peak to peak voltage on Sin, Sinref, Cos and Cosref. This results in a 2V peak to peak voltage seen at the drive's encoder terminals. It is not recommended that encoders of this type are used with Digitax ST, and that the encoder feedback signals should meet the above parameters (1V peak to peak).

Resolution: The sinewave frequency can be up to 500kHz but the resolution is reduced at high frequency. Table 4-3 shows the number of bits of interpolated information at different frequencies and with different voltage levels at the drive encoder port. The total resolution in bits per revolution is the ELPR plus the number of bits of interpolated information. Although it is possible to obtain 11 bits of interpolation information, the nominal design value is 10 bits.

* Not used with EndAt and SSI communications only encoders.

Table 4-3 Feedback resolution based on frequency and voltage level

Volt/Freq	1kHz	5kHz	50kHz	100kHz	200kHz	500kHz
1.2	11	11	10	10	9	8
1.0	11	11	10	9	9	7
0.8	10	10	10	9	8	7
0.6	10	10	9	9	8	7
0.4	9	9	9	8	7	6

5	Data**
6	Data**
11	Clock***
12	Clock***

Type	EIA 485 differential transceivers
Maximum frequency	2MHz
Line loading	32 unit loads (for terminals 5 and 6) 1 unit load (for terminals 11 and 12)
Working common mode range	+12V to -7V
Absolute maximum applied voltage relative to 0V	+14V to -9V
Absolute maximum applied differential voltage	+14V to -9V

** Not used with SC encoders.

*** Not used with SC and SC.HiPEr encoders.

14	0V common
-----------	------------------

15	Motor thermistor input
-----------	-------------------------------

This terminal is connected internally to terminal 8 of the signal connector. Connect only one of these terminals to a motor thermistor. Analog input 3 must be in thermistor mode, Pr 7.15 = th.SC (7), th (8) or th.diSP (9).

4.2.2 Buffered encoder output

Table 4-4 Encoder output types

Setting of Pr 3.54	Description
Ab (0)	Quadrature outputs
Fd (1)	Frequency and direction outputs
Fr (2)	Frequency and reverse outputs
Ab.L (3)	Quadrature outputs with marker lock
Fd.L (4)	Frequency and direction outputs with marker lock

Table 4-5 Buffered encoder connections

Term.	Setting of Pr 3.54				
	Ab (0)	Fd (1)	Fr (2)	Ab.L (3)	Fd.L (4)
1	A	F	F	A	F
2	A\	F\	F\	A\	F\
3	B	D	R	B	D
4	B\	D\	R\	B\	D\
5	Z*				
6	Z*				
14	0V				

*Available when marker pulse input connected

1	A, F
2	A\, F\
3	B, D, R
4	B\, D\, R\
5	Z
6	Z\

Type	EIA 485 differential transmitter
Max frequency	512 KHz
Max load capability	31 units
Working common mode range	+12V to -7V
Absolute maximum applied voltage relative to 0V	+14V to -14V

14	0V common
-----------	------------------

4.2.3 Digitax ST Plus additional connections

Figure 4-3 Digitax ST Plus terminals view

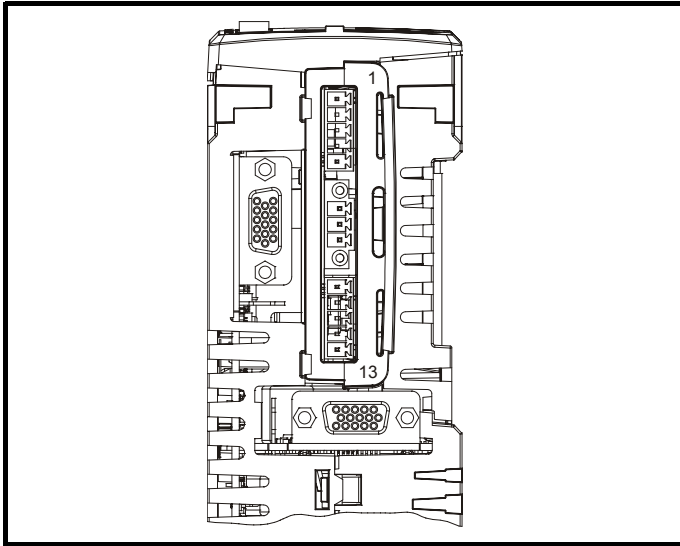

Table 4-6 Digitax ST Plus connector details

Terminal	Function	Description
1	0V SC	0V connection for EIA-RS485 port
2	RX\	EIA-RS485 negative receive line (Input)
3	RX	EIA-RS485 positive receive line (Input)
4	TX\	EIA-RS485 negative transmit line (Output)
5	TX	EIA-RS485 positive transmit line (Output)
6	Channel A	CTNet
7	Shielded	Connection of shielding via CTNet
8	Channel B	CTNet
9	0V	0V connection for digital I/O
10	DIO	Digital input 0
11	DI1	Digital input 1
12	DO0	Digital output 0
13	DO1	Digital output 1

4.3 Serial communications connections

The drive has a serial communications port (serial port) as standard supporting 2 wire EIA485 communications. Please see Table 4-7 for the connection details for the RJ45 connector.

Figure 4-4 Location of the RJ45 serial comms connector

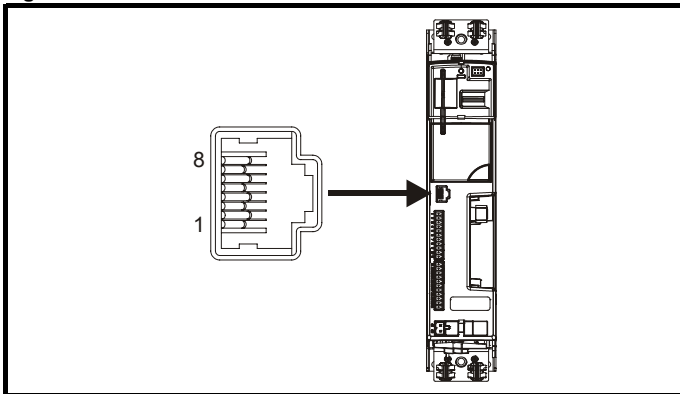

Table 4-7 Connection details for RJ45 connector

Pin	Function
1	120Ω Termination resistor
2	RX TX
3	Isolated 0V
4	+24V (100mA)
5	Isolated 0V
6	TX enable
7	RX\ TX\
8	RX\ TX\ (if termination resistors are required, link to pin 1)
Shield	Isolated 0V

The communications port applies a 2 unit load to the communications network.

Minimum number of connections are 2, 3, 7 and shield. Shielded cable must be used at all times.

4.3.1 Isolation of the serial communications port

The serial communications port is double insulated and meets the requirements for SELV in IEC61800-5-1.



WARNING

In order to meet the requirements for SELV in IEC60950 (IT equipment) it is necessary for the control computer to be grounded. Alternatively, when a lap-top or similar device is used which has no provision for grounding, an isolation device must be incorporated in the communications lead.

An isolated serial communications lead has been designed to connect the drive to IT equipment (such as lap-top computers), and is available from the supplier of the drive. See below for details:

Table 4-8 Isolated serial comms lead details

Part number	Description
CT -COMMS Cable	Double insulated RS232/RS485 Cable
USB/485 Converter	USB/RS484 Cable

The "isolated serial communications" lead has reinforced insulation as defined in IEC60950 for altitudes up to 3,000m.

NOTE

When using the CT EIA232 Comms cable the available baud rate is limited to 19.2k baud.

5 EMC filters

5.1 External EMC filter rating

Table 5-1 External EMC filter ratings

Used with	Number of phases	Filter part number	Power losses at rated current	IP rating	Weight		Operational leakage current	Worst case leakage current	Filter terminal tightening torque		Filter current rating
			W		Kg	lb			mA	mA	
ST X.XA M/TL	1	FS23072-19-07	11	20	1.2	2.64	29.48	56.85	0.8	0.6	19
ST X.XA M/TL	3	FS23073-17-07	13	20	1.2	2.64	8	50	0.8	0.6	17
ST X.XA T	3	FS23074-11-07	10	20	1.2	2.64	16	90	0.8	0.6	11

Figure 5-1 External EMC filter dimensions

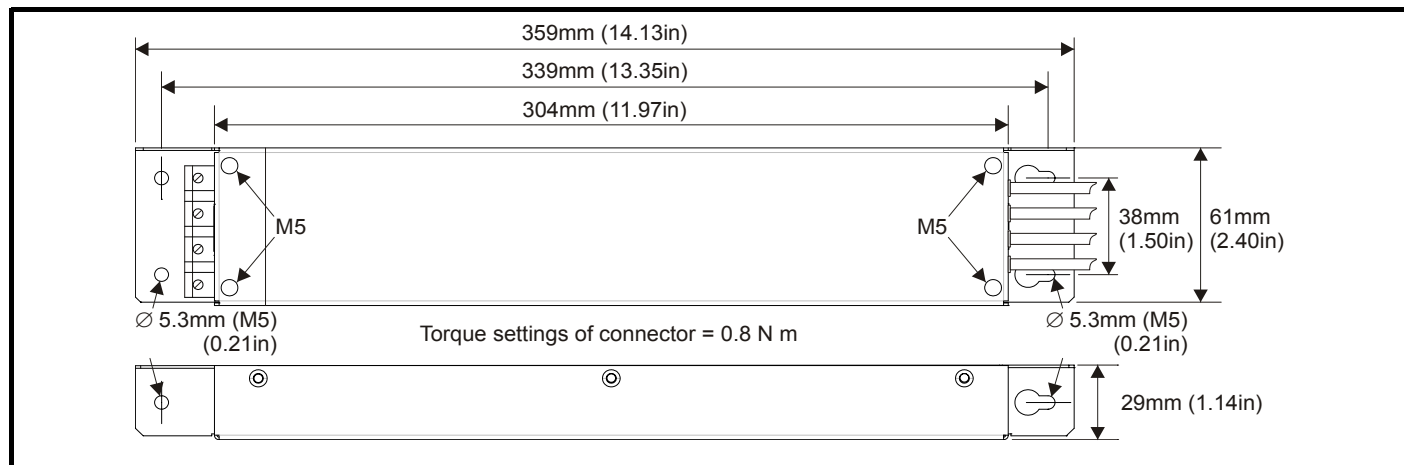

5.2 Internal and external conducted emissions conformity

Table 5-2 Conformity with internal filter

Used with	No of phases	Motor cable length m	Filter and switching frequency		
			Internal		
			6kHz	8kHz	12kHz
ST X.XA M/TL	1				
ST X.XA M/TL	1				
ST X.XA M/TL	3	0 to 7	E2U	E2U	E2U
ST X.XA M/TL	3	7 to 9	E2U	E2U	E2R
ST X.XA M/TL	3	9 to 50	E2R	E2R	E2R
ST X.XA T	3	0 to 6	E2U	E2R	E2R
ST X.XA T	3	6 to 50	E2R	E2R	E2R

Table 5-3 Conformity with external filter

Used with	No of phases	Motor cable length m	Filter and switching frequency		
			External		
			6kHz	8kHz	12kHz
All	1 or 3	0 to 20	R	I	I
All	1 or 3	20 to 50	I	I	I

Key to Table 5-2 and Table 5-3

(shown in decreasing order of permitted emission level):

- E2R EN 61800-3 second environment, restricted distribution (Additional measures may be required to prevent interference)
- E2U EN 61800-3 second environment, unrestricted distribution
- I Industrial generic standard EN 50081-2 (EN 61000-6-4) EN 61800-3 first environment restricted distribution (The following caution is required by EN 61800-3)

This is a product of the restricted distribution class according to IEC 61800-3. In a residential environment this product may cause radio interference in which case the user may be required to take adequate measures.

CAUTION

R Residential generic standard EN 50081-1 (EN 61000-6-3) EN 61800-3 first environment unrestricted distribution

EN 61800-3 defines the following:

- The first environment is one that includes domestic premises. It also includes establishments directly connected without intermediate transformers to a low-voltage power supply network which supplies buildings used for domestic purposes.
- The second environment is one that includes all establishments other than those directly connected to a low-voltage power supply network which supplies buildings used for domestic purposes.
- Restricted distribution is defined as a mode of sales distribution in which the manufacturer restricts the supply of equipment to suppliers, customers or users who separately or jointly have technical competence in the EMC requirements of the application of drives.

NOTE

Where the drive is incorporated into a system with rated input current exceeding 100A, the higher emission limits of EN 61800-3 for the second environment are applicable, and no filter is then required.

NOTE

Operation without an external filter is a practical cost-effective possibility in an industrial installation where existing levels of electrical noise are likely to be high, and any electronic equipment in operation has been designed for such an environment. This is in accordance with EN 61800-3 in the second environment, with restricted distribution. There is some risk of disturbance to other equipment, and in this case the user and supplier of the drive system must jointly take responsibility for correcting any problem which occurs.

6 Options

All Solutions Modules are color-coded in order to make identification easy. The following table shows the color-code key and gives further details on their function.

Table 6-1 Solutions Module identification











Type	Solutions Module	Color	Name	Further Details
Feedback		Light Green	SM-Universal Encoder Plus	Universal Feedback interface Feedback interface for the following devices: Inputs <ul style="list-style-type: none"> • Incremental encoders • SinCos encoders • SSI encoders • EnDat encoders Outputs <ul style="list-style-type: none"> • Quadrature • Frequency and direction • SSI simulated outputs
		Light Blue	SM-Resolver	Resolver interface Feedback interface for resolvers. Simulated quadrature encoder outputs
		Brown	SM-Encoder Plus	Incremental encoder interface Feedback interface for incremental encoders without commutation signals. No simulated encoder outputs available
		N/A	15-way D-type converter	Drive encoder input converter Provides screw terminal interface for encoder wiring and spade terminal for shield
Automation (I/O Expansion)		Yellow	SM-I/O Plus	Extended I/O interface Increases the I/O capability by adding the following to the existing I/O in the drive: <ul style="list-style-type: none"> • Digital inputs x 3 • Digital I/O x 3 • Analog inputs (voltage) x 2 • Analog output (voltage) x 1 • Relay x 2
		Yellow	SM-I/O 32	Extended I/O interface Increase the I/O capability by adding the following to the existing I/O in the drive: <ul style="list-style-type: none"> • High speed digital I/O x 32 • +24V output
		Dark Yellow	SM-I/O Lite	Additional I/O 1 x Analog input ($\pm 10V$ bi-polar or current modes) 1 x Analog output (0-10V or current modes) 3 x Digital input and 1 x Relay
		Dark Red	SM-I/O Timer	Additional I/O with real time clock As per SM-I/O Lite but with the addition of a Real Time Clock for scheduling drive running
		Turquoise	SM-I/O PELV	Isolated I/O to NAMUR NE37 specifications For chemical industry applications 1 x Analog input (current modes) 2 x Analog outputs (current modes) 4 x Digital input / outputs, 1 x Digital input, 2 x Relay outputs
		Olive	SM-I/O 120V	Additional I/O conforming to IEC 61131-2 120Vac 6 digital inputs and 2 relay outputs rated for 120Vac operation
		Cobalt Blue	SM-I/O 24V Protected	Additional I/O with overvoltage protection up to 48V 2 x Analog outputs (current modes) 4 x Digital input / outputs, 3 x Digital inputs, 2 x Relay outputs

Table 6-1 Solutions Module identification







Type	Solutions Module	Color	Name	Further Details
Fieldbus		Purple	SM-PROFIBUS-DP	Profibus option PROFIBUS DP adapter for communications with the drive
		Medium Grey	SM-DeviceNet	DeviceNet option Devicenet adapter for communications with the drive
		Dark Grey	SM-INTERBUS	Interbus option Interbus adapter for communications with the drive
		Pink	SM-CAN	CAN option CAN adapter for communications with the drive
		Light Grey	SM-CANopen	CANopen option CANopen adapter for communications with the drive
		Red	SM-SERCOS	SERCOS option Class B compliant. Torque velocity and position control modes supported with data rates (bit/sec): 2MB, 4MB, 8MB and 16MB. Minimum 250µsec network cycle time. Two digital high speed probe inputs 1µsec for position capture
		Beige	SM-Ethernet	Ethernet option 10 base-T / 100 base-T; Supports web pages, SMTP mail and multiple protocols: DHCP IP addressing; Standard RJ45 connection
		Pale Green	SM-LON	LonWorks option LonWorks adapter for communications with the drive

Table 6-2 Keypad identification





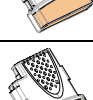

Type	Keypad	Name	Further Details
Keypad		Digitax ST Keypad	LED keypad option Keypad with a LED display
		SM-Keypad Plus	Remote keypad option Keypad with an alpha-numeric LCD display with Help function

Table 6-3 Other options

Type	Option	Name	Further details
EMC		EMC Filters	These additional filters are designed to operate together with the drive's own integral EMC filter in areas of sensitive equipment
Communications		CT Comms cable	Cable with isolation RS232 to RS485 converter. For connecting PC/Laptop to the drive when using the various interface softwares (e.g. CTSOft)
		CTSOft	Software for PC or Laptop which allows the user to commission and store parameter settings
		SyPTLite	Software for PC or Laptop which allows the user to program PLC functions within the drive
Internal braking resistor		Braking resistor	Optional braking resistor 70R 50W
SMARTCARD		SMARTCARD	Standard feature that enables simple configuration of parameters in a variety of ways

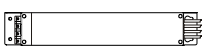
7 General data

Table 7-1

Type	Details
Weight	2.1 kg (4.6 lb)
IP Rating	IP20
Ambient operating temperature	Ambient temperature operating range: 0°C to 50°C (32°F to 122°F) Output current derating must be applied at ambient temperatures >40°C (104°F)
Storage temperature	-40°C (-40°F) to +50°C (122°F) for long term storage, or to +70°C (158°F) for short term storage
Altitude	Altitude range: 0 to 3,000m (9,900 ft), subject to the following conditions: 1,000m to 3,000m (3,300 ft to 9,900 ft) above sea level: derate the maximum output current from the specified figure by 1% per 100m (330 ft) above 1,000m (3,300 ft) For example at 3,000m (9,900ft) the output current of the drive would have to be derated by 20%.
Operating humidity	Maximum relative humidity 95% non-condensing
Storage humidity	Maximum relative humidity 93%
Vibration	<p>Bump Test Testing in each of three mutually perpendicular axes in turn. Referenced standard: IEC 60068-2-29: Test Eb: Severity: 18g, 6ms, half sine No. of Bumps: 600 (100 in each direction of each axis)</p> <p>Random Vibration Test Testing in each of three mutually perpendicular axes in turn. Referenced standard: IEC 60068-2-64: Test Fh: Severity: 1.0 m²/s³ (0.01 g²/Hz) ASD from 5 - 20 Hz -3 dB/octave from 20 to 200 Hz Duration: 30 minutes in each of 3 mutually perpendicular axes</p> <p>Sinusoidal Vibration Test Testing in each of three mutually perpendicular axes in turn. Referenced standard: IEC 60068-2-6: Test Fc: Frequency range: 2* to 500 Hz Severity: 3.5 mm peak displacement from 2* to 9 Hz 10 m/s² peak acceleration from 9 to 200 Hz 15 m/s² peak acceleration from 200 to 500 Hz Sweep rate: 1 octave/minute Duration: 15 minutes in each of 3 mutually perpendicular axes * or lowest achievable on an electromagnetic shaker</p>
Speed resolution	Preset speed reference: 0.1rpm Precision speed reference: 0.001rpm Analog input 1: 16bit plus sign Analog input 2: 10bit plus sign
Current /Torque resolution	10bit plus sign
Current/Torque accuracy	2%
Output speed range	Speed range: 0 to 40,000 rpm
Starts per hour	60 starts per hour equally spaced
Start up time	This is the time taken from the moment of applying power to the drive, to the drive being ready to run the motor: 4s
Acoustic noise	Fan at high speed: 65dB Fan at low speed: 53dB
Toxic materials	Digitax ST meets EU directive 2002-95-EC (RoHS compliance)

8 Diagnostics





Users must not attempt to repair a drive if it is faulty, nor carry out fault diagnosis other than through the use of the diagnostic features described in this chapter.
If a drive is faulty, it must be returned to an authorized Leroy Somer distributor for repair.

The display on the drive gives various information about the status of the drive. These fall into three categories:

- Trip indications
- Alarm indications
- Status indications

Table 8-1 Trip indications

Trip	Diagnosis
br.th	Braking resistor thermistor temperature monitoring fail
10	If no brake resistor is installed, set Pr 0.51 (or Pr 10.37) to 8 to disable this trip. If a brake resistor is installed: Ensure that the braking resistor thermistor is connected correctly Ensure that the fan in the drive is working correctly Replace the braking resistor
C.Acc	SMARTCARD trip: SMARTCARD Read / Write fail
185	Check SMARTCARD is installed / located correctly Ensure SMARTCARD is not writing data to data location 500 to 999 Replace SMARTCARD
C.boot	SMARTCARD trip: The menu 0 parameter modification cannot be saved to the SMARTCARD because the necessary file has not been created on the SMARTCARD
177	A write to a menu 0 parameter has been initiated via the keypad with Pr 11.42 set to auto(3) or boot(4), but the necessary file on the SMARTCARD has not been created Ensure that Pr 11.42 is correctly set and reset the drive to create the necessary file on the SMARTCARD Re-attempt the parameter write to the menu 0 parameter
C.bUSY	SMARTCARD trip: SMARTCARD can not perform the required function as it is being accessed by a Solutions Module
178	Wait for the Solutions Module to finish accessing the SMARTCARD and then re-attempt the required function
C.Chg	SMARTCARD trip: Data location already contains data
179	Erase data in data location Write data to an alternative data location
C.cPr	SMARTCARD trip: The values stored in the drive and the values in the data block on the SMARTCARD are different
188	Press the red  reset button
C.dAt	SMARTCARD trip: Data location specified does not contain any data
183	Ensure data block number is correct
C.Err	SMARTCARD trip: SMARTCARD data is corrupted
182	Ensure the card is located correctly Erase data and retry Replace SMARTCARD
C.Full	SMARTCARD trip: SMARTCARD full
184	Delete a data block or use different SMARTCARD
cL2	Analog input 2 current loss (current mode)
28	Check analog input 2 (terminal 7) current signal is present (4-20mA, 20-4mA)
cL3	Analog input 3 current loss (current mode)
29	Check analog input 3 (terminal 8) current signal is present (4-20mA, 20-4mA)
CL.bit	Trip initiated from the control word (Pr 6.42)
35	Disable the control word by setting Pr 6.43 to 0 or check setting of Pr 6.42
C.OPtn	SMARTCARD trip: Solutions Modules installed are different between source drive and destination drive
180	Ensure correct Solutions Modules are installed Ensure Solutions Modules are in the same Solutions Module slot Press the red  reset button

Introduction	Product ratings	Drive dimensions	I/O Specification	EMC filters	Options	General data	Diagnostics	Index																						
Trip	Diagnosis																													
C.Prod	SMARTCARD trip: The data blocks on the SMARTCARD are not compatible with this product																													
175	Erase all data on the SMARTCARD by setting Pr xx.00 to 9999 and pressing the red  reset button Replace SMARTCARD																													
C.rdo	SMARTCARD trip: SMARTCARD has the Read Only bit set																													
181	Enter 9777 in Pr xx.00 to allow SMARTCARD Read / Write access Ensure card is not writing to data locations 500 to 999																													
C.rtg	SMARTCARD trip: The voltage and/or current rating of the source and destination drives are different																													
186	<p>Drive rating dependent parameters (parameters with the RA coding) are likely to have different values and ranges with drives of different voltage and current ratings. Parameters with this attribute will not be transferred to the destination drive by SMARTCARDS when the rating of the destination drive is different from the source drive and the file is a parameter file. Drive rating dependent parameters will be transferred if only the current rating is different and the file is a differences from default type file.</p> <p>Press the red  reset button</p> <p>Drive rating parameters are:</p> <table border="1" data-bbox="268 577 1066 934"> <thead> <tr> <th>Parameter</th> <th>Function</th> </tr> </thead> <tbody> <tr> <td>2.08</td> <td>Standard ramp voltage</td> </tr> <tr> <td>4.05/6/7, 21.27/8/9</td> <td>Current limits</td> </tr> <tr> <td>4.24</td> <td>User current maximum scaling</td> </tr> <tr> <td>5.07, 21.07</td> <td>Motor rated current</td> </tr> <tr> <td>5.09, 21.09</td> <td>Motor rated voltage</td> </tr> <tr> <td>5.17, 21.12</td> <td>Stator resistance</td> </tr> <tr> <td>5.18</td> <td>Switching frequency</td> </tr> <tr> <td>5.23, 21.13</td> <td>Voltage offset</td> </tr> <tr> <td>5.24, 21.14</td> <td>Transient inductance</td> </tr> <tr> <td>6.48</td> <td>Line power supply loss ride through detection level</td> </tr> </tbody> </table> <p>The above parameters will be set to their default values.</p>								Parameter	Function	2.08	Standard ramp voltage	4.05/6/7, 21.27/8/9	Current limits	4.24	User current maximum scaling	5.07, 21.07	Motor rated current	5.09, 21.09	Motor rated voltage	5.17, 21.12	Stator resistance	5.18	Switching frequency	5.23, 21.13	Voltage offset	5.24, 21.14	Transient inductance	6.48	Line power supply loss ride through detection level
Parameter	Function																													
2.08	Standard ramp voltage																													
4.05/6/7, 21.27/8/9	Current limits																													
4.24	User current maximum scaling																													
5.07, 21.07	Motor rated current																													
5.09, 21.09	Motor rated voltage																													
5.17, 21.12	Stator resistance																													
5.18	Switching frequency																													
5.23, 21.13	Voltage offset																													
5.24, 21.14	Transient inductance																													
6.48	Line power supply loss ride through detection level																													
C.TyP	SMARTCARD trip: SMARTCARD parameter set not compatible with drive																													
187	Press the reset button Ensure destination drive type is the same as the source parameter file drive type																													
dESt	Two or more parameters are writing to the same destination parameter																													
199	Set Pr xx.00 = 12001 check all visible parameters in the menus for duplication																													
EEF	EEPROM data corrupted - Drive mode becomes open loop and serial comms will timeout with remote keypad on the drive RS485 comms port.																													
31	This trip can only be cleared by loading default parameters and saving parameters																													
Enc1	Drive encoder trip: Encoder power supply overload																													
189	Check encoder power supply wiring and encoder current requirement Maximum current = 200mA @ 15V, or 300mA @ 8V and 5V																													
Enc2	Drive encoder trip: Wire break (Drive encoder terminals 1 & 2, 3 & 4, 5 & 6)																													
190	Check cable continuity Check wiring of feedback signals is correct Check encoder power is set correctly Replace feedback device If wire break detection on the main drive encoder input is not required, set Pr 3.40 = 0 to disable the Enc2 trip																													
Enc3	Drive encoder trip: Phase offset incorrect While running																													
191	Check the encoder signal for noise Check encoder shielding Check the integrity of the encoder mechanical mounting Repeat the offset measurement test																													
Enc4	Drive encoder trip: Feedback device comms failure																													
192	Ensure encoder power supply is correct Ensure baud rate is correct Check encoder wiring Replace feedback device																													
Enc5	Drive encoder trip: Checksum or CRC error																													
193	Check the encoder signal for noise Check the encoder cable shielding With EnDat encoders, check the comms resolution and/or carry out the auto-configuration Pr 3.41																													

Introduction	Product ratings	Drive dimensions	I/O Specification	EMC filters	Options	General data	Diagnostics	Index
Trip	Diagnosis							
Enc6	Drive encoder trip: Encoder has indicated an error							
194	Replace feedback device With SSI encoders, check the wiring and encoder supply setting							
Enc7	Drive encoder trip: Initialisation failed							
195	Re-set the drive Check the correct encoder type is entered into Pr 3.38 Check encoder wiring Check encoder power supply is set correctly Carry out the auto-configuration Pr 3.41 Replace feedback device							
Enc8	Drive encoder trip: Auto configuration on power up has been requested and failed							
196	Change the setting of Pr 3.41 to 0 and manually enter the drive encoder turns (Pr 3.33) and the equivalent number of lines per revolution (Pr 3.34) Check the comms resolution							
Enc9	Drive encoder trip: Position feedback selected is selected from a Solutions Module slot which does not have a speed / position feedback Solutions Module installed							
197	Check setting of Pr 3.26 (or Pr 21.21 if the second motor parameters have been enabled)							
Enc10	Drive encoder trip: Servo mode phasing failure because encoder phase angle (Pr 3.25 or Pr 21.20) is incorrect							
198	Check the encoder wiring. Perform an autotune to measure the encoder phase angle or manually enter the correct phase angle into Pr 3.25 (or Pr 21.20). Spurious Enc10 trips can be seen in very dynamic applications. This trip can be disabled by setting the overspeed threshold in Pr 3.08 to a value greater than zero. Caution should be used in setting the over speed threshold level as a value which is too large may mean that an encoder fault will not be detected.							
Enc11	Drive encoder trip: A failure has occurred during the alignment of the analog signals of a SINCOS encoder with the digital count derived from the sine and cosine waveforms and the comms position (if applicable). This fault is usually due to noise on the sine and cosine signals.							
161	Check encoder cable shield. Examine sine and cosine signals for noise.							
Enc12	Drive encoder trip: Hiperface encoder - The encoder type could not be identified during auto-configuration							
162	Check encoder type can be auto-configured. Check encoder wiring. Enter parameters manually.							
Enc13	Drive encoder trip: EnDat encoder - The number of encoder turns read from the encoder during auto-configuration is not a power of 2							
163	Select a different type of encoder.							
Enc14	Drive encoder trip: EnDat encoder - The number of comms bits defining the encoder position within a turn read from the encoder during auto-configuration is too large.							
164	Select a different type of encoder. Faulty encoder.							
Enc15	Drive encoder trip: The number of periods per revolution calculated from encoder data during auto-configuration is either less than 2 or greater than 50,000.							
165	Linear motor pole pitch / encoder ppr set up is incorrect or out of parameter range i.e. Pr 5.36 = 0 or Pr 21.31 = 0. Faulty encoder.							
Enc16	Drive encoder trip: EnDat encoder - The number of comms bits per period for a linear encoder exceeds 255.							
166	Select a different type of encoder. Faulty encoder.							
Enc17	Drive encoder trip: The periods per revolution obtained during auto-configuration for a rotary SINCOS encoder is not a power of two.							
167	Select a different type of encoder. Faulty encoder.							
ENP.Er	Data error from electronic nameplate stored in selected position feedback device							
176	Replace feedback device							

Introduction	Product ratings	Drive dimensions	I/O Specification	EMC filters	Options	General data	Diagnostics	Index
Trip	Diagnosis							
Et	External trip from input on terminal 31							
6	Check terminal 31 signal Check value of Pr 10.32 Enter 12001 in Pr xx.00 and check for parameter controlling Pr 10.32 Ensure Pr 10.32 or Pr 10.38 (=6) are not being controlled by serial comms							
HF01	Data processing error: CPU address error							
	Hardware fault - return drive to supplier							
HF02	Data processing error: DMAC address error							
	Hardware fault - return drive to supplier							
HF03	Data processing error: Illegal instruction							
	Hardware fault - return drive to supplier							
HF04	Data processing error: Illegal slot instruction							
	Hardware fault - return drive to supplier							
HF05	Data processing error: Undefined exception							
	Hardware fault - return drive to supplier							
HF06	Data processing error: Reserved exception							
	Hardware fault - return drive to supplier							
HF07	Data processing error: Watchdog failure							
	Hardware fault - return drive to supplier							
HF08	Data processing error: Level 4 crash							
	Hardware fault - return drive to supplier							
HF09	Data processing error: Heap overflow							
	Hardware fault - return drive to supplier							
HF10	Data processing error: Router error							
	Hardware fault - return drive to supplier							
HF11	Data processing error: Access to EEPROM failed							
	Hardware fault - return drive to supplier							
HF12	Data processing error: Main program stack overflow							
	Hardware fault - return drive to supplier							
HF13	Data processing error: Software incompatible with hardware							
	Hardware or software fault - return drive to supplier							
HF17	Multi-module system thermistor short circuit or open circuit							
217	Hardware fault - return drive to supplier							
HF18	Multi-module system interconnect cable error							
218	Hardware fault - return drive to supplier							
HF19	Temperature feedback multiplexing failure							
219	Hardware fault - return drive to supplier							
HF20	Power stage recognition: serial code error							
220	Hardware fault - return drive to supplier							
HF21	Power stage recognition: unrecognised frame size							
221	Hardware fault - return drive to supplier							
HF22	Power stage recognition: multi module frame size mismatch							
222	Hardware fault - return drive to supplier							
HF23	Power stage recognition: multi module voltage rating mismatch							
223	Hardware fault - return drive to supplier							
HF24	Power stage recognition: unrecognised drive size							
224	Hardware fault - return drive to supplier							

Introduction	Product ratings	Drive dimensions	I/O Specification	EMC filters	Options	General data	Diagnostics	Index
Trip	Diagnosis							
HF25	Current feedback offset error							
225	Hardware fault - return drive to supplier							
HF26	Soft start relay failed to close, soft start monitor failed or braking IGBT short circuit at power up							
226	Hardware fault - return drive to supplier							
HF27	Power stage thermistor 1 fault							
227	Hardware fault - return drive to supplier							
HF29	Control board thermistor fault							
229	Hardware fault - return drive to supplier							
HF30	DCCT wire break trip from power module							
230	Hardware fault - return drive to supplier							
lt.AC	Output current overload timed out (I^2t) - accumulator value can be seen in Pr 4.19							
20	<p>Ensure the load is not jammed / sticking Check the load on the motor has not changed If seen during an autotune in servo mode, ensure that the motor rated current Pr 0.46 (Pr 5.07) or Pr 21.07 is current rating of the drive Tune the rated speed parameter Check feedback device signal for noise Check the feedback device mechanical coupling</p>							
lt.br	Braking resistor overload timed out (I^2t) – accumulator value can be seen in Pr 10.39							
19	<p>Ensure the values entered in Pr 10.30 and Pr 10.31 are correct Increase the power rating of the braking resistor and change Pr 10.30 and Pr 10.31 If an external thermal protection device is being used and the braking resistor software overload is not required, set Pr 10.30 or Pr 10.31 to 0 to disable the trip</p>							
L.SYnC	Drive failed to synchronize to the supply voltage in Regen mode							
O.CtL	Drive control board over temperature							
23	<p>Check enclosure / drive fans are still functioning correctly Check enclosure ventilation paths Check enclosure door filters Check ambient temperature Reduce drive switching frequency</p>							
O.ht1	Power device over temperature based on thermal model							
21	<p>Reduce drive switching frequency Reduce duty cycle Decrease acceleration / deceleration rates Reduce motor load</p>							
O.ht2	Heatsink over temperature							
22	<p>Check enclosure / drive fans are still functioning correctly Check enclosure ventilation paths Check enclosure door filters Increase ventilation Decrease acceleration / deceleration rates Reduce drive switching frequency Reduce duty cycle Reduce motor load</p>							
O.ht3	Drive over-temperature based on thermal model							
27	<p>The drive will attempt to stop the motor before tripping. If the motor does not stop in 10s the drive trips immediately. Check enclosure / drive fans are still functioning correctly Check enclosure ventilation paths Check enclosure door filters Increase ventilation Decrease acceleration / deceleration rates Reduce duty cycle Reduce motor load</p>							

Introduction	Product ratings	Drive dimensions	I/O Specification	EMC filters	Options	General data	Diagnostics	Index									
Trip	Diagnosis																
OI.AC	Instantaneous output over current detected																
3	<p>Acceleration /deceleration rate is too short. If seen during autotune reduce voltage boost Pr 5.15 Check for short circuit on output cabling Check integrity of motor insulation Check feedback device wiring Check feedback device mechanical coupling Check feedback signals are free from noise Is motor cable length within limits Reduce the values in speed loop gain parameters – Pr 3.10, Pr 3.11 and Pr 3.12 Has offset measurement test been completed? Reduce the values in current loop gain parameters - Pr 4.13 and Pr 4.14</p>																
OI.br	Braking transistor over-current detected: short circuit protection for the braking transistor activated																
4	<p>Check braking resistor wiring Check braking resistor value is greater than or equal to the minimum resistance value Check braking resistor insulation</p>																
O.Ld1	Digital output overload: total current drawn from 24V supply and digital outputs exceeds 200mA																
26	Check total load on digital outputs (terminals 24,25,26)and +24V rail (terminal 22)																
O.SPd	Motor speed has exceeded the over speed threshold																
7	<p>Increase the over speed trip threshold in Pr 3.08 Reduce the speed loop P gain (Pr 3.10) to reduce the speed overshoot</p>																
OV	DC bus voltage has exceeded the peak level or the maximum continuous level for 15 seconds																
2	<p>Increase deceleration ramp (Pr 0.04) Decrease braking resistor value (staying above the minimum value) Check nominal AC supply level Check for supply disturbances which could cause the DC bus to rise – voltage overshoot after supply recovery from a notch induced by DC drives. Check motor insulation</p> <table border="1"> <thead> <tr> <th>Drive voltage rating</th> <th>Peak voltage</th> <th>Maximum continuous voltage level (15s)</th> </tr> </thead> <tbody> <tr> <td>200</td> <td>415</td> <td>400</td> </tr> <tr> <td>400</td> <td>830</td> <td>800</td> </tr> </tbody> </table> <p>If the drive is operating in low voltage DC mode the overvoltage trip level is 1.45 x Pr 6.46.</p>								Drive voltage rating	Peak voltage	Maximum continuous voltage level (15s)	200	415	400	400	830	800
Drive voltage rating	Peak voltage	Maximum continuous voltage level (15s)															
200	415	400															
400	830	800															
PAd	Keypad has been removed when the drive is receiving the speed reference from the keypad																
34	<p>Instal keypad and reset Change speed reference selector to select speed reference from another source</p>																
PH	AC voltage input phase loss or large supply imbalance detected																
32	<p>Ensure all three phases are present and balanced Check input voltage levels are correct (at full load)</p> <p>NOTE</p> <p>Load level must be between 50 and 100% for the drive to trip under phase loss conditions. The drive will attempt to stop the motor before this trip is initiated.</p>																
PS	Internal power supply fault																
5	<p>Remove any Solutions Modules and reset Hardware fault - return drive to supplier</p>																
PS.10V	10V user power supply current greater than 10mA																
8	<p>Check wiring to terminal 4 Reduce load on terminal 4</p>																
PS.24V	24V internal power supply overload																
9	<p>The total user load of the drive and Solutions Modules has exceeded the internal 24V power supply limit. The user load consists of the drive's digital outputs, the SM-I/O Plus digital outputs, the drive's main encoder supply and the SM-Universal Encoder Plus encoder supply.</p> <ul style="list-style-type: none"> • Reduce load and reset • Provide an external 24V >50W power supply • Remove any Solutions Modules and reset 																
PSAVE.Er	Power down save parameters in the EEPROM are corrupt																
37	<p>Indicates that the power was removed when power down save parameters were being saved. The drive will revert back to the power down parameter set that was last saved successfully. Perform a user save (Pr xx.00 to 1000 or 1001 and reset the drive) or power down the drive normally to ensure this trip does or occur the next time the drive is powered up.</p>																

Introduction	Product ratings	Drive dimensions	I/O Specification	EMC filters	Options	General data	Diagnostics	Index
Trip	Diagnosis							
SAVE.Er	User save parameters in the EEPROM are corrupt							
36	Indicates that the power was removed when user parameters were being saved. The drive will revert back to the user parameter set that was last saved successfully. Perform a user save (Pr xx.00 to 1000 or 1001 and reset the drive) to ensure this trip does or occur the next time the drive is powered up.							
SCL	Drive RS485 serial comms loss to remote keypad							
30	Re-install the cable between the drive and keypad Check cable for damage Replace cable Replace keypad							
SLX.dF	Solutions Module slot X trip: Solutions Module type installed in slot X changed							
204,209	Save parameters and reset							

Trip	Diagnosis		
SLX.Er	Solutions Module slot X trip: Solutions Module in slot X has detected a fault		
	Feedback module category		
	Check value in Pr 15/16.50 . The following table lists the possible error codes for the SM-Universal Encoder Plus, SM-Encoder Plus and SM-Resolver. See the <i>Diagnostics</i> section in the relevant Solutions Module User Guide for more information.		
	Error code	Module	Trip Description
	0	All	No trip
			No fault detected
	1	SM-Universal Encoder Plus	Encoder power supply overload
		SM-Resolver	Excitation output short circuit
			Check encoder power supply wiring and encoder current requirement Maximum current = 200mA @ 15V, or 300mA @ 8V and 5V
			Check the excitation output wiring.
	2	SM-Universal Encoder Plus & SM-Resolver	Wire break
	3	SM-Universal Encoder Plus	Phase offset incorrect while running
	4	SM-Universal Encoder Plus	Feedback device communications failure
	5	SM-Universal Encoder Plus	Checksum or CRC error
	6	SM-Universal Encoder Plus	Encoder has indicated an error
	7	SM-Universal Encoder Plus	Initialisation failed
202,207,212	8	SM-Universal Encoder Plus	Auto configuration on power up has been requested and failed
	9	SM-Universal Encoder Plus	Motor thermistor trip
	10	SM-Universal Encoder Plus	Motor thermistor short circuit
	11	SM-Universal Encoder Plus	Failure of the sincos analog position alignment during encoder initialisation
	11	SM-Resolver	Poles not compatible with motor
	12	SM-Universal Encoder Plus	Encoder type could not be identified during auto-configuration
	13	SM-Universal Encoder Plus	Number of encoder turns read from the encoder during auto-configuration is not a power of 2
	14	SM-Universal Encoder Plus	Number of comms bits defining the encoder position within a turn read from the encoder during auto-configuration is too large.
15	SM-Universal Encoder Plus	The number of periods per revolution calculated from encoder data during auto-configuration is either <2 or >50,000.	
			Linear motor pole pitch / encoder ppr set up is incorrect or out of parameter range i.e. Pr 5.36 = 0 or Pr 21.31 = 0. Faulty encoder.
16	SM-Universal Encoder Plus	The number of comms bits per period for a linear encoder exceeds 255.	
			Select a different type of encoder. Faulty encoder.
74	All	Solutions Module has overheated	
			Check ambient temperature Check enclosure ventilation

Trip	Diagnosis																																																																																										
SLX.Er	Solutions Module slot X trip: Solutions Module in slot X or Digitax ST Plus/Indexer has detected a fault																																																																																										
202,207,212	<p>Automation (Applications) module category</p> <p>Check value in Pr 17.50. The following table lists the possible error codes for the Digitax ST Plus and Digitax ST Indexer. See the <i>Diagnostics</i> section in the Advanced User Guide for more information.</p> <table border="1"> <thead> <tr> <th>Error Code</th> <th>Trip Description</th> </tr> </thead> <tbody> <tr><td>39</td><td>User program stack overflow</td></tr> <tr><td>40</td><td>Unknown error - please contact supplier</td></tr> <tr><td>41</td><td>Parameter does not exist</td></tr> <tr><td>42</td><td>Attempt to write to a read-only parameter</td></tr> <tr><td>43</td><td>Attempt to read from a write-only parameter</td></tr> <tr><td>44</td><td>Parameter value out of range</td></tr> <tr><td>45</td><td>Invalid synchronisation modes</td></tr> <tr><td>46</td><td>Unused</td></tr> <tr><td>47</td><td>Synchronisation lost with CTSync Master</td></tr> <tr><td>48</td><td>RS485 not in user mode</td></tr> <tr><td>49</td><td>Invalid RS485 configuration</td></tr> <tr><td>50</td><td>Maths error - divide by zero or overflow</td></tr> <tr><td>51</td><td>Array index out of range</td></tr> <tr><td>52</td><td>Control word user trip</td></tr> <tr><td>53</td><td>DPL program incompatible with target</td></tr> <tr><td>54</td><td>DPL task overrun</td></tr> <tr><td>55</td><td>Unused</td></tr> <tr><td>56</td><td>Invalid timer unit configuration</td></tr> <tr><td>57</td><td>Function block does not exist</td></tr> <tr><td>58</td><td>Flash PLC Storage corrupt</td></tr> <tr><td>59</td><td>Drive rejected application module as Sync master</td></tr> <tr><td>60</td><td>CTNet hardware failure. Please contact your supplier</td></tr> <tr><td>61</td><td>CTNet invalid configuration</td></tr> <tr><td>62</td><td>CTNet invalid baud-rate</td></tr> <tr><td>63</td><td>CTNet invalid node ID</td></tr> <tr><td>64</td><td>Digital Output overload</td></tr> <tr><td>65</td><td>Invalid function block parameter(s)</td></tr> <tr><td>66</td><td>User heap too large</td></tr> <tr><td>67</td><td>RAM file does not exist or a non-RAM file id has been specified</td></tr> <tr><td>68</td><td>The RAM file specified is not associated to an array</td></tr> <tr><td>69</td><td>Failed to update drive parameter database cache in Flash memory</td></tr> <tr><td>70</td><td>User program downloaded while drive enabled</td></tr> <tr><td>71</td><td>Failed to change drive mode</td></tr> <tr><td>72</td><td>Invalid CTNet buffer operation</td></tr> <tr><td>73</td><td>Fast parameter initialisation failure</td></tr> <tr><td>74</td><td>Over-temperature</td></tr> <tr><td>75</td><td>Hardware unavailable</td></tr> <tr><td>76</td><td>Module type cannot be resolved. Module is not recognised.</td></tr> <tr><td>77</td><td>Inter-option module comms error with module in slot 1</td></tr> <tr><td>78</td><td>Inter-option module comms error with module in slot 2</td></tr> <tr><td>79</td><td>Inter-option module comms error with module in slot 3</td></tr> <tr><td>80</td><td>Inter-option module comms error with module unknown slot</td></tr> <tr><td>81</td><td>APC internal error</td></tr> <tr><td>82</td><td>Communications to drive faulty</td></tr> </tbody> </table>	Error Code	Trip Description	39	User program stack overflow	40	Unknown error - please contact supplier	41	Parameter does not exist	42	Attempt to write to a read-only parameter	43	Attempt to read from a write-only parameter	44	Parameter value out of range	45	Invalid synchronisation modes	46	Unused	47	Synchronisation lost with CTSync Master	48	RS485 not in user mode	49	Invalid RS485 configuration	50	Maths error - divide by zero or overflow	51	Array index out of range	52	Control word user trip	53	DPL program incompatible with target	54	DPL task overrun	55	Unused	56	Invalid timer unit configuration	57	Function block does not exist	58	Flash PLC Storage corrupt	59	Drive rejected application module as Sync master	60	CTNet hardware failure. Please contact your supplier	61	CTNet invalid configuration	62	CTNet invalid baud-rate	63	CTNet invalid node ID	64	Digital Output overload	65	Invalid function block parameter(s)	66	User heap too large	67	RAM file does not exist or a non-RAM file id has been specified	68	The RAM file specified is not associated to an array	69	Failed to update drive parameter database cache in Flash memory	70	User program downloaded while drive enabled	71	Failed to change drive mode	72	Invalid CTNet buffer operation	73	Fast parameter initialisation failure	74	Over-temperature	75	Hardware unavailable	76	Module type cannot be resolved. Module is not recognised.	77	Inter-option module comms error with module in slot 1	78	Inter-option module comms error with module in slot 2	79	Inter-option module comms error with module in slot 3	80	Inter-option module comms error with module unknown slot	81	APC internal error	82	Communications to drive faulty
	Error Code	Trip Description																																																																																									
	39	User program stack overflow																																																																																									
	40	Unknown error - please contact supplier																																																																																									
	41	Parameter does not exist																																																																																									
	42	Attempt to write to a read-only parameter																																																																																									
	43	Attempt to read from a write-only parameter																																																																																									
	44	Parameter value out of range																																																																																									
	45	Invalid synchronisation modes																																																																																									
	46	Unused																																																																																									
	47	Synchronisation lost with CTSync Master																																																																																									
	48	RS485 not in user mode																																																																																									
	49	Invalid RS485 configuration																																																																																									
	50	Maths error - divide by zero or overflow																																																																																									
	51	Array index out of range																																																																																									
	52	Control word user trip																																																																																									
	53	DPL program incompatible with target																																																																																									
	54	DPL task overrun																																																																																									
	55	Unused																																																																																									
	56	Invalid timer unit configuration																																																																																									
	57	Function block does not exist																																																																																									
	58	Flash PLC Storage corrupt																																																																																									
	59	Drive rejected application module as Sync master																																																																																									
	60	CTNet hardware failure. Please contact your supplier																																																																																									
	61	CTNet invalid configuration																																																																																									
	62	CTNet invalid baud-rate																																																																																									
	63	CTNet invalid node ID																																																																																									
	64	Digital Output overload																																																																																									
	65	Invalid function block parameter(s)																																																																																									
	66	User heap too large																																																																																									
	67	RAM file does not exist or a non-RAM file id has been specified																																																																																									
	68	The RAM file specified is not associated to an array																																																																																									
	69	Failed to update drive parameter database cache in Flash memory																																																																																									
70	User program downloaded while drive enabled																																																																																										
71	Failed to change drive mode																																																																																										
72	Invalid CTNet buffer operation																																																																																										
73	Fast parameter initialisation failure																																																																																										
74	Over-temperature																																																																																										
75	Hardware unavailable																																																																																										
76	Module type cannot be resolved. Module is not recognised.																																																																																										
77	Inter-option module comms error with module in slot 1																																																																																										
78	Inter-option module comms error with module in slot 2																																																																																										
79	Inter-option module comms error with module in slot 3																																																																																										
80	Inter-option module comms error with module unknown slot																																																																																										
81	APC internal error																																																																																										
82	Communications to drive faulty																																																																																										

Trip	Diagnosis		
SLX.Er	Solutions Module slot X trip: Solutions Module in slot X has detected a fault		
202,207,212	Automation (I/O Expansion) module category		
	Check value in Pr 15/16.50 . The following table lists the possible error codes for the SM-I/O Plus, SM-I/O Lite, SM-I/O Timer, SM-I/O PELV, SM-I/O 120V and SM-I/O 24V Protected. See the <i>Diagnostics</i> section in the relevant Solutions Module User Guide for more information.		
	Error code	Module	Reason for fault
	0	All	No errors
	1	All	Digital output overload
	2	SM-I/O Lite, SM-I/O Timer	Analog input 1 current input too high (>22mA) or too low (<3mA)
		SM-I/O PELV, SM-I/O 24V Protected	Digital input overload
	3	SM-I/O PELV, SM-I/O 24V Protected	Analog input 1 current input too low (<3mA)
		SM-I/O 24V Protected	Communications error
	4	SM-I/O PELV	User power supply absent
	5	SM-I/O Timer	Real time clock communication error
74	All	Module over temperature	
SLX.Er	Solutions Module slot X trip: Solutions Module in slot X has detected a fault		
202,207,212	Fieldbus module category		
	Check value in Pr 15/16.50 . The following table lists the possible error codes for the Fieldbus modules. See the <i>Diagnostics</i> section in the relevant Solutions Module User Guide for more information.		
	Error code	Module	Trip Description
	0	All	No trip
	52	SM-PROFIBUS-DP, SM-Interbus, SM-DeviceNet, SM-CANOpen	User control word trip
	61	SM-PROFIBUS-DP, SM-Interbus, SM-DeviceNet, SM-CANOpen, SM-SERCOS	Configuration error
	64	SM-DeviceNet	Expected packet rate timeout
	65	SM-PROFIBUS-DP, SM-Interbus, SM-DeviceNet, SM-CANOpen, SM-SERCOS	Network loss
	66	SM-PROFIBUS-DP	Critical link failure
		SM-CAN, SM-DeviceNet, SM-CANOpen	Bus off error
	69	SM-CAN	No acknowledgement
	70	All (except SM-Ethernet)	Flash transfer error
		SM-Ethernet	No valid menu data available for the module from the drive
	74	All	Solutions module over temperature
	75	SM-Ethernet	The drive is not responding
	76	SM-Ethernet	The Modbus connection has timed out
	80	All (except SM-SERCOS)	Inter-option communications error
	81	All (except SM-SERCOS)	Communications error to slot 1
	82	All (except SM-SERCOS)	Communications error to slot 2
	83	All (except SM-SERCOS)	Communications error to slot 3
	84	SM-Ethernet	Memory allocation error
	85	SM-Ethernet	File system error
	86	SM-Ethernet	Configuration file error
	87	SM-Ethernet	Language file error
	98	All	Internal watchdog error
	99	All	Internal software error

Trip	Diagnosis																																												
SLX.Er	Solutions Module slot X trip: Solutions Module in slot X has detected a fault																																												
202,207,212	SLM module category Check value in Pr 15/16.50 . The following table lists the possible error codes for the SM-SLM. For more information, contact LEROY-SOMER.																																												
	<table border="1"> <thead> <tr> <th>Error Code</th> <th>Trip Description</th> </tr> </thead> <tbody> <tr><td>0</td><td>No fault detected</td></tr> <tr><td>1</td><td>Power supply overloaded</td></tr> <tr><td>2</td><td>SLM version is too low</td></tr> <tr><td>3</td><td>DriveLink error</td></tr> <tr><td>4</td><td>Incorrect switching frequency selected</td></tr> <tr><td>5</td><td>Feedback source selection incorrect</td></tr> <tr><td>6</td><td>Encoder error</td></tr> <tr><td>7</td><td>Motor object number of instances error</td></tr> <tr><td>8</td><td>Motor object list version error</td></tr> <tr><td>9</td><td>Performance object number of instances error</td></tr> <tr><td>10</td><td>Parameter channel error</td></tr> <tr><td>11</td><td>Drive operating mode incompatible</td></tr> <tr><td>12</td><td>Error writing to the SLM EEPROM</td></tr> <tr><td>13</td><td>Motor object type incorrect</td></tr> <tr><td>14</td><td>Digitax ST object error</td></tr> <tr><td>15</td><td>Encoder object CRC error</td></tr> <tr><td>16</td><td>Motor object CRC error</td></tr> <tr><td>17</td><td>Performance object CRC error</td></tr> <tr><td>18</td><td>Digitax ST object CRC error</td></tr> <tr><td>19</td><td>Sequencer timeout</td></tr> <tr><td>74</td><td>Solutions module over temperature</td></tr> </tbody> </table>	Error Code	Trip Description	0	No fault detected	1	Power supply overloaded	2	SLM version is too low	3	DriveLink error	4	Incorrect switching frequency selected	5	Feedback source selection incorrect	6	Encoder error	7	Motor object number of instances error	8	Motor object list version error	9	Performance object number of instances error	10	Parameter channel error	11	Drive operating mode incompatible	12	Error writing to the SLM EEPROM	13	Motor object type incorrect	14	Digitax ST object error	15	Encoder object CRC error	16	Motor object CRC error	17	Performance object CRC error	18	Digitax ST object CRC error	19	Sequencer timeout	74	Solutions module over temperature
	Error Code	Trip Description																																											
	0	No fault detected																																											
	1	Power supply overloaded																																											
	2	SLM version is too low																																											
	3	DriveLink error																																											
	4	Incorrect switching frequency selected																																											
	5	Feedback source selection incorrect																																											
	6	Encoder error																																											
	7	Motor object number of instances error																																											
	8	Motor object list version error																																											
	9	Performance object number of instances error																																											
	10	Parameter channel error																																											
	11	Drive operating mode incompatible																																											
	12	Error writing to the SLM EEPROM																																											
	13	Motor object type incorrect																																											
	14	Digitax ST object error																																											
	15	Encoder object CRC error																																											
	16	Motor object CRC error																																											
17	Performance object CRC error																																												
18	Digitax ST object CRC error																																												
19	Sequencer timeout																																												
74	Solutions module over temperature																																												
SLX.HF	Solutions Module slot X trip: Solutions Module X hardware fault																																												
200,205,210	Ensure Solutions Module is installed correctly Return Solutions Module to supplier																																												
SLX.nF	Solutions Module slot X trip: Solutions Module has been removed																																												
203,208,213	Ensure Solutions Module is installed correctly Re-instal Solutions Module Save parameters and reset drive																																												
SL.rtd	Solutions Module trip: Drive mode has changed and Solutions Module parameter routing is now incorrect																																												
215	Press reset. If the trip persists, contact the supplier of the drive.																																												
SLX.tO	Solutions Module slot X trip: Solutions Module watchdog timeout																																												
201,206,211	Press reset. If the trip persists, contact the supplier of the drive.																																												
t010	User trip defined in 2nd processor Solutions Module code																																												
10	SM-Applications program must be interrogated to find the cause of this trip																																												
t038	User trip defined in 2nd processor Solutions Module code																																												
38	SM-Applications program must be interrogated to find the cause of this trip																																												
t040 to t089	User trip defined in 2nd processor Solutions Module code																																												
40 to 89	SM-Applications program must be interrogated to find the cause of this trip																																												
t099	User trip defined in 2nd processor Solutions Module code																																												
99	SM-Applications program must be interrogated to find the cause of this trip																																												
t101	User trip defined in 2nd processor Solutions Module code																																												
101	SM-Applications program must be interrogated to find the cause of this trip																																												
t112 to t160	User trip defined in 2nd processor Solutions Module code																																												
112 to 160	SM-Applications program must be interrogated to find the cause of this trip																																												

Introduction	Product ratings	Drive dimensions	I/O Specification	EMC filters	Options	General data	Diagnostics	Index
Trip	Diagnosis							
t168 to t175	User trip defined in 2nd processor Solutions Module code							
168 to 175	SM-Applications program must be interrogated to find the cause of this trip							
t216	User trip defined in 2nd processor Solutions Module code							
216	SM-Applications program must be interrogated to find the cause of this trip							
th	Motor thermistor trip							
24	Check motor temperature Check thermistor continuity Set Pr 7.15 = VOLt and reset the drive to disable this function							
thS	Motor thermistor short circuit							
25	Check motor thermistor wiring Replace motor / motor thermistor Set Pr 7.15 = VOLt and reset the drive to disable this function							
tunE*	Autotune stopped before completion							
18	The drive has tripped out during the autotune The red stop key has been pressed during the autotune The SECURE DISABLE INPUT signal (terminal 31) was active during the autotune procedure							
tunE1*	The position feedback did not change or required speed could not be reached during the inertia test (see Pr 5.12)							
11	Ensure the motor is free to turn i.e. brake was released. Check feedback device wiring is correct Check feedback parameters are set correctly Check encoder coupling to motor							
tunE2*	Position feedback direction incorrect or motor could not be stopped during the inertia test (see Pr 5.12)							
12	Check motor cable wiring is correct. Check feedback device wiring is correct Swap any two motor phases (closed loop vector only)							
tunE3*	Drive encoder commutation signals connected incorrectly or measured inertia out of range (see Pr 5.12)							
13	Check motor cable wiring is correct. Check feedback device U,V and W commutation signal wiring is correct							
tunE4*	Drive encoder U commutation signal fail during an autotune							
14	Check feedback device U phase commutation wires continuity Replace encoder							
tunE5*	Drive encoder V commutation signal fail during an autotune							
15	Check feedback device V phase commutation wires continuity Replace encoder							
tunE6*	Drive encoder W commutation signal fail during an autotune							
16	Check feedback device W phase commutation wires continuity Replace encoder							
tunE7*	Motor number of poles set incorrectly							
17	Check lines per revolution for feedback device Check the number of poles in Pr 5.11 is set correctly							
UP ACC	Onboard PLC program: cannot access Onboard PLC program file on drive							
98	Disable drive - write access is not allowed when the drive is enabled Another source is already accessing Onboard PLC program - retry once other action is complete							
UP div0	Onboard PLC program attempted divide by zero							
90	Check program							
UP OFL	Onboard PLC program variables and function block calls using more than the allowed RAM space (stack overflow)							
95	Check program							
UP ovr	Onboard PLC program attempted out of range parameter write							
94	Check program							
UP PAr	Onboard PLC program attempted access to a non-existent parameter							
91	Check program							
UP ro	Onboard PLC program attempted write to a read-only parameter							
92	Check program							
UP So	Onboard PLC program attempted read of a write-only parameter							
93	Check program							

Introduction	Product ratings	Drive dimensions	I/O Specification	EMC filters	Options	General data	Diagnostics	Index
Trip	Diagnosis							
UP udF	Onboard PLC program un-defined trip							
97	Check program							
UP uSEr	Onboard PLC program requested a trip							
96	Check program							
UV	DC bus under voltage threshold reached							
1	Check AC supply voltage level							
	Drive voltage rating (Vac)	Under voltage threshold (Vdc)	UV reset voltage (Vdc)					
	200	175	215V					
	400	350	425V					

*If a tunE through tunE trip occurs, then after the drive is reset the drive cannot be made to run unless it is disabled via the SECURE DISABLE INPUT input (terminal 31), drive enable parameter (Pr 6.15) or the control word (Pr 6.42 and Pr 6.43).

Table 8-2 Serial communications look-up table

No.	Trip	No.	Trip	No.	Trip
1	UV	40 to 89	t040 to t089	182	C.Err
2	OV	90	UP div0	183	C.dAt
3	OI.AC	91	UP PAr	184	C.FULL
4	OI.br	92	UP ro	185	C.Acc
5	PS	93	UP So	186	C.rtg
6	Et	94	UP ovr	187	C.TyP
7	O.SPd	95	UP OFL	188	C.cPr
8	PS.10V	96	UP uSEr	189	Enc1
9	PS.24V	97	UP udF	190	Enc2
10	br.th	98	UP ACC	191	Enc3
11	tunE1	99	t099	192	Enc4
12	tunE2	100		193	Enc5
13	tunE3	101	t101	194	Enc6
15	tunE5	103	OI.br.P	196	Enc8
16	tunE6	104	OIAC.P	197	Enc9
17	tunE7	105	Oht2.P	198	Enc10
18	tunE	106	OV.P	199	DESt
19	It.br	107	PH.P	200	SL1.HF
20	It.AC	108	PS.P	201	SL1.tO
21	O.ht1	109	OldC.P	202	SL1.Er
24	th	112 to 160	t112 to t160	205	SL2.HF
25	thS	161	Enc11	206	SL2.tO
26	O.Ld1	162	Enc12	207	SL2.Er
27	O.ht3	163	Enc13	208	SL2.nF
28	cL2	164	Enc14	209	SL2.dF
29	cL3	165	Enc15	210	SL3.HF
30	SCL	166	Enc16	211	SL3.tO
31	EEF	167	Enc17	212	SL3.Er
32	PH	168 to 174	t168 to t174	213	SL3.nF
33	rS	175	C.Prod	214	SL3.dF
34	PAd	176	EnP.Er	215	SL.rtd
35	CL.bit	177	C.boot	216	t216
36	SAVE.Er	178	C.bUSY	217 to 232	HF17 to HF32
37	PSAVE.Er	179	C.Chg		
38	t038	180	C.OPtn		
39	L.SYnC	181	C.RdO		

Introduction	Product ratings	Drive dimensions	I/O Specification	EMC filters	Options	General data	Diagnostics	Index
--------------	-----------------	------------------	-------------------	-------------	---------	--------------	--------------------	-------

The trips can be grouped into the following categories. It should be noted that a trip can only occur when the drive is not tripped or is already tripped but with a trip with a lower priority number.

Table 8-3 Trip categories

Priority	Category	Trips	Comments
1	Hardware faults	HF01 to HF16	These indicate serious internal problems and cannot be reset. The drive is inactive after one of these trips and the display shows HFxx . The Drive OK relay opens and the serial comms will not function.
2	Non-resetable trips	HF17 to HF32, SL1.HF, SL2.HF	Cannot be reset. Requires the drive to be powered down.
3	EEF trip	EEF	Cannot be reset unless a code to load defaults is first entered in Pr xx.00 or Pr 11.43 .
4	SMARTCARD trips	C.boot, C.Busy, C.Chg, C.OPtn, C.RdO, C.Err, C.dat, C.FULL, C.Acc, C.rtg, C.TyP, C.cpr	Can be reset after 1.0s SMARTCARD trips have priority 5 during power-up
4	supply trips	PS.24V	Can be reset after 1.0s
5	Autotune	tunE, tunE1 to tunE	Can be reset after 1.0s, but the drive cannot be made to run unless it is disabled via the SECURE DISABLE INPUT input (terminal 31), <i>Drive enable</i> (Pr 6.15) or the <i>Control word</i> (Pr 6.42 and Pr 6.43).
5	Normal trips with extended reset	OI.AC, OI.Br, OIAC.P, OIBr.P, OldC.P	Can be reset after 10.0s
5	Normal trips	All other trips not included in this table	Can be reset after 1.0s
5	Non-important trips	th, thS, Old1, cL2, cL3, SCL	If Pr 10.37 is 1 or 3 the drive will stop before tripping
5	Phase loss	PH	The drive attempts to stop before tripping
5	Drive over-heat based on thermal model	O.ht3	The drive attempts to stop before tripping, but if it does not stop within 10s the drive will automatically trip
6	Self-resetting trips	UV	Under voltage trip cannot be reset by the user, but is automatically reset by the drive when the supply voltage is with specification

Although the UV trip operates in a similar way to all other trips, all drive functions can still operate but the drive cannot be enabled. The following differences apply to the UV trip:

1. Power-down save user parameters are saved when UV trip is activated except when the main high voltage supply is not active (i.e. operating in Low Voltage DC Supply Mode, Pr **6.44** = 1).
2. The UV trip is self-resetting when the DC bus voltage rises above the drive restart voltage level. If another trip is active instead of UV at this point, the trip is not reset.
3. The drive can change between using the main high voltage supply and low voltage DC supply only when the drive is in the under voltage condition (Pr **10.16** = 1). The UV trip can only be seen as active if another trip is not active in the under voltage condition.
4. When the drive is first powered up a UV trip is initiated if the supply voltage is below the restart voltage level and another trip is not active. This does not cause save power down save parameters to be saved at this point.

8.1 Alarm indications

In any mode an alarm flashes alternately with the data displayed when one of the following conditions occur. If action is not taken to eliminate any alarm except "Autotune", "Lt" and "PLC" the drive may eventually trip. Alarms flash once every 640ms except "PLC" which flashes once every 10s. Alarms are not displayed when a parameter is being edited.

Table 8-4 Alarm indications

Lower display	Description
br.rS	Braking resistor overload
	Braking resistor I^2t accumulator (Pr 10.39) in the drive has reached 75.0% of the value at which the drive will trip and the braking IGBT is active.
Hot	Heatsink or control board or inverter IGBT over temperature alarms are active
	<ul style="list-style-type: none"> The drive heatsink temperature has reached a threshold and the drive will trip O.ht2 if the temperature continues to rise (see the O.ht2 trip). Or <ul style="list-style-type: none"> The ambient temperature around the control PCB is approaching the over temperature threshold (see the O.CtL trip).
OVLd	Motor overload
	The motor I^2t accumulator (Pr 4.19) in the drive has reached 75% of the value at which the drive will be tripped and the load on the drive is >100%
Auto tune	Autotune in progress
	The autotune procedure has been initialised. 'Auto' and 'tunE' will flash alternatively on the display.
Lt	Limit switch is active
	Indicates that a limit switch is active and that it is causing the motor to be stopped (i.e. forward limit switch with forward reference etc.)
PLC	Onboard PLC program is running
	An Onboard PLC program is installed and running. The lower display will flash 'PLC' once every 10s.

8.2 Status indications

Table 8-5 Status indications

Upper display	Description	Drive output stage
ACUU	AC Supply loss The drive has detected that the AC supply has been lost and is attempting to maintain the DC bus voltage by decelerating the motor.	Enabled
dc	DC applied to the motor The drive is applying DC injection braking.	Enabled
dEC	Decelerating The drive is decelerating the motor.	Enabled
inh	Inhibit The drive is inhibited and cannot be run. The drive enable signal is not applied to terminal 31 or Pr 6.15 is set to 0.	Disabled
POS	Positioning The drive is positioning/orientating the motor shaft.	Enabled
rdY	Ready The drive is ready to be run.	Disabled
run	Running The drive is running.	Enabled
SCAn	Scanning Regen> The drive is enabled and is synchronising to the line.	Enabled
StoP	Stop or holding zero speed The drive is holding zero speed. Regen> The drive is enabled but the AC voltage is too low, or the DC bus voltage is still rising or falling.	Enabled
triP	Trip condition The drive has tripped and is no longer controlling the motor. The trip code appears on the lower display.	Disabled

Table 8-6 Solutions Module and SMARTCARD status indications at power-up

Lower display	Description
boot	A parameter set is being transferred from the SMARTCARD to the drive during power-up. For further information, refer to the <i>User Guide</i> .
cArd	The drive is writing a parameter set to the SMARTCARD during power-up. For further information, refer to the <i>User Guide</i> .
loAging	The drive is writing information to a Solutions Module.

Index

Symbols

+10V user output	15
+24V external input	15
+24V user output	16

Numerics

0V common	15
-----------------	----

A

Acoustic noise	24
Alarm	38
Alarm Indications	38
Altitude	24
Analog input 2	15
Analog input 3	15
Analog output 1	16
Analog output 2	16

B

Bump test	24
-----------------	----

D

Diagnostics	25
Digital I/O 1	16
Digital I/O 2	16
Digital I/O 3	16
Digital Input 1	16
Digital Input 2	16
Digital Input 3	16
Display messages	38, 39
Drive enable	17

E

Encoder types	17
---------------------	----

H

Humidity	
Operating	24
Storage	24

I

IP Rating	24
-----------------	----

P

Precision reference Analog input 1	15
--	----

R

Random vibration test	24
Relay contacts	17
Resolution	24
RJ45 connector - connection details	20

S

Serial comms lead	20
Serial communications look-up table	37
Serial communications port isolation	20
Sinusoidal vibration test	24
Start up time	24
Starts per hour	24
Status	39
Status Indications	39

T

Temperature	
Ambient operating	24
Storage	24
Trip categories	38

V

Vibration	24
-----------------	----

W

Weight	24
--------------	----



0475-0024-01