

DYNEO[®]

**Synchronous motors
with permanent magnets-drive**

Commissioning

DYNEO®

Synchronous motors with permanent magnets-drive

NOTE

LEROY-SOMER reserves the right to modify the characteristics of its products at any time in order to incorporate the latest technological developments. The information contained in this document may therefore be changed without notice.



For the user's own safety, the variable speed drive must be connected to an approved earth (\perp terminal).

If accidentally starting the installation is likely to cause a risk to personnel or the machines being driven, it is essential to comply with the power connection diagrams recommended in this manual.

The variable speed drive is fitted with safety devices which, in the event of a problem, control stopping and thus stop the motor. The motor itself can become jammed for mechanical reasons. Voltage fluctuations, and in particular power cuts, may also cause the motor to stop. The removal of the causes of the shutdown can lead to restarting, which may be dangerous for certain machines or installations.

In such cases, it is essential that the user takes appropriate precautions against the motor restarting after an unscheduled stop.

The variable speed drive is designed to be able to supply a motor and the driven machine above its rated speed.

If the motor or the machine are not mechanically designed to withstand such speeds, the user may be exposed to serious danger resulting from their mechanical deterioration.

It is important that the user checks that the installation can withstand it before programming a high speed.

The variable speed drive which is the subject of this manual is designed to be integrated in an installation or an electrical machine, and can under no circumstances be considered to be a safety device. It is therefore the responsibility of the machine manufacturer, the designer of the installation or the user to take all necessary precautions to ensure that the system complies with current standards, and to provide any devices required to ensure the safety of equipment and personnel.

LEROY-SOMER declines all responsibility in the event of the above recommendations not being observed.

.....

This manual is not a substitute for the drive installation and commissioning manuals.

DYNEO®**Synchronous motors with permanent magnets-drive****CONTENTS**

1 - COMMISSIONING OF LSRPM MAGNETS MOTOR WITH FEEDBACK VIA ENCODER WITH COMMUTATION CHANNELS OR HALL EFFECT SENSOR, CONTROLLED BY A POWERDRIVE DRIVE	4
1.1 - Connecting the sensor on the motor end (standard).....	4
1.2 - Simplified commissioning with POWERDRIVE drive	4
2 - COMMISSIONING OF LSRPM MAGNETS MOTOR WITH FEEDBACK VIA HALL EFFECT SENSOR, CONTROLLED BY A UNIDRIVE SP DRIVE.....	6
3 - COMMISSIONING OF LSRPM MAGNETS MOTOR WITH FEEDBACK VIA ENCODER WITH COMMUTATION CHANNELS, CONTROLLED BY A UNIDRIVE SP DRIVE	8
3.1 - Connecting the sensor on the motor end (standard).....	8
3.2 - Simplified commissioning with UNIDRIVE SP drive	8
4 - COMMISSIONING FOR CONTROL OF AN LSRPM MOTOR IN «SENSORLESS» MODE (PARAMETER 00.14)	10
5 - CONNECTIONS	11
5.1 - Motors	11
5.2 - Hall effect sensor.....	11
5.3 - Incremental encoder with UVW commutation channels.....	12
5.4 - Forced ventilation	12
5.5 - Brake	13
5.6 - PTC sensors.....	13

DYNEO®

Synchronous motors with permanent magnets-drive

1 - COMMISSIONING OF LSRPM MAGNETS MOTOR WITH FEEDBACK VIA ENCODER WITH COMMUTATION CHANNELS OR HALL EFFECT SENSOR, CONTROLLED BY A POWERDRIVE DRIVE

1.1 - Connecting the sensor on the motor end (standard)

Encoder with commutation channels

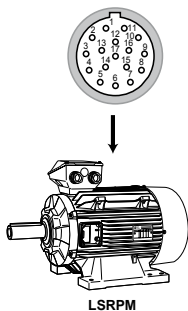

No.	Designation	MD-Encoder terminal block (3)
1	x	x
2	x	x
3	x	x
4	U or S1	U
5	U\ or S1\	U\
6	V or S2	V
7	V\ or S2\	V\
8	W or S3	W
9	W\ or S3\	W\
10	A	x
11	C or O or Z	x
12	C\ or O\ or Z\	x
13	A\	A\
14	B	B
15	B\	B\
16	+5V or +15V	+
17	0V	-
	Shielding (2)	≡

MD-ENCODER (3)



Use shielded cable on each pair (U,U\), (V,V\)...
The thermal sensor is connected in the motor terminal box (1)

Hall Effect sensor

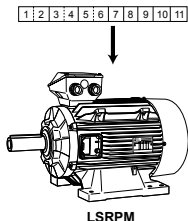

No.	Designation	MD-Encoder terminal block (3)
1	U	U
2	W\	W\
3	V	V
4	U\	U\
5	W	W
6	V\	V\
7	0V	-
8	+15V	+
9	Shielding	≡
10	Motor thermal sensor (1)	T1
11		T2

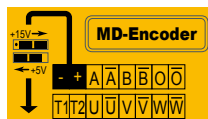

Use shielded cable on each pair (U,U\), (V,V\)...

(1) The thermal sensor connected in the motor terminal box should be connected to terminals T1, T2 of the MD-Encoder option. Set **07.56** 56 to Enabled.

(2) Connect the shielding 360° round the connector.

(3) Powerdrive option used to manage the motor speed feedback

1.2 - Simplified commissioning with POWERDRIVE drive

Drive off, check that ...

- Terminals SDI1 and SDI2 are connected in order to run the power self-test (see **17.03**)
- The run command has not been enabled
- The motor is connected and the order of the motor phases is respected
- For information, the standard feedback is as follows:

Feedback	Encoder	Hall effect sensor
Supply	5V	15V
No. of lines	1024	-

- The MD-Encoder option is connected, including the commutation channels and the shielding, the supply voltage is positioned on 15V for the Hall effect sensor and on 5V or 15V for the encoder depending on which type is used.



DYNEO®

Synchronous motors with permanent magnets-drive

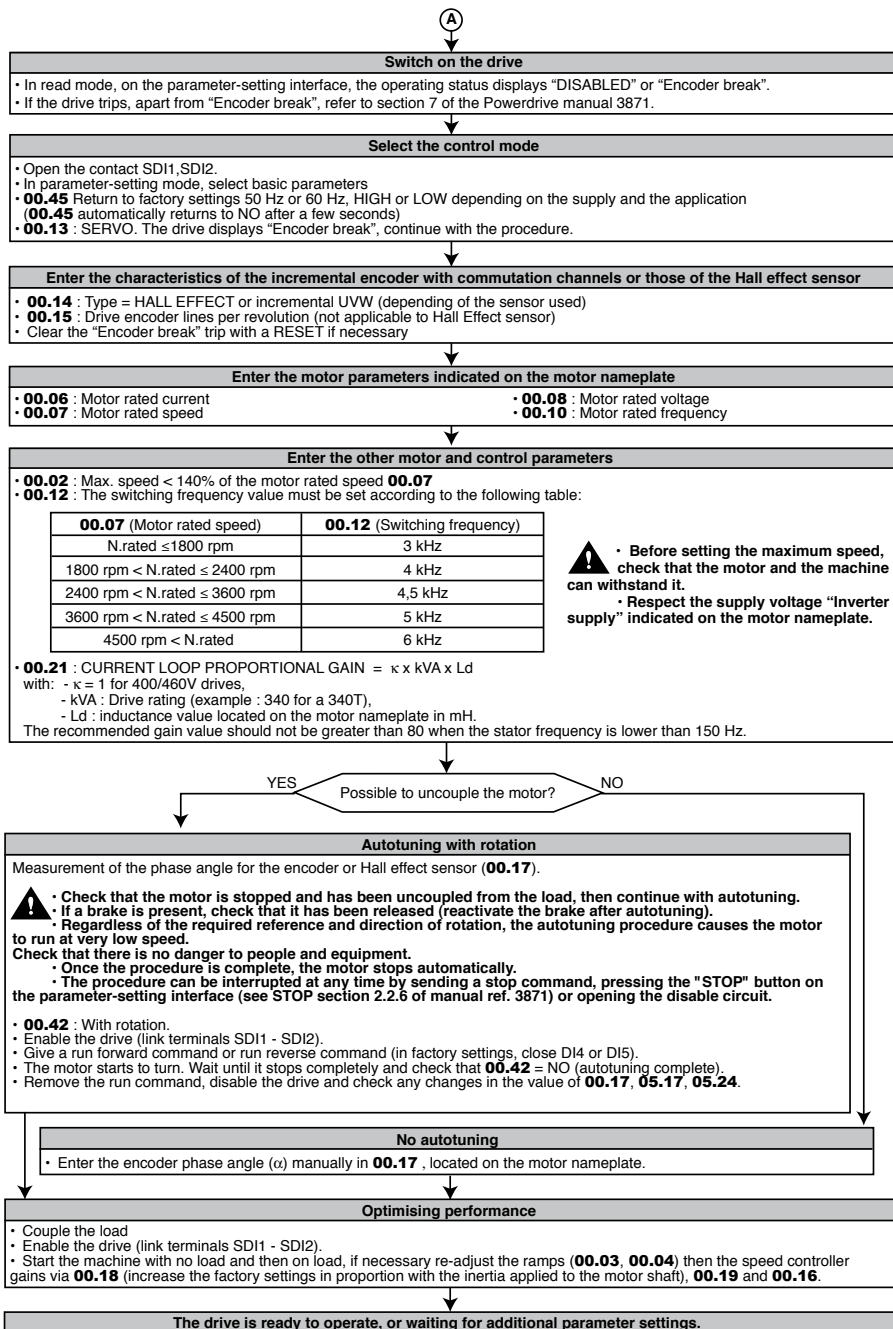

DYNEO®

Synchronous motors with permanent magnets-drive

2 - COMMISSIONING OF LSRPMM MAGNETS MOTOR WITH FEEDBACK VIA HALL EFFECT SENSOR, CONTROLLED BY A UNIDRIVE SP DRIVE

Drive off, check that ...

- The order of the motor phases is respected.
- The wiring from the sensor to UT02 conforms to section L11 of manual 3616.
- The connections have been made as indicated below, depending on which motor is used.

1 2 3 4 5 6 7 8 9 10 11

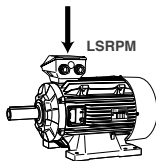

11-pin terminal block on Hall effect sensor and	UT02 terminal block
1 U	3 U
2 W	x x
3 V	4 V
4 UV	x x
5 W	5 W
6 V	x x
7 OV	2 OV
8 +15V	1 +15V
9 Shielding	⊕ ⊕
10 Motor thermal sensor (*)	x x
11	

(*) Connect to terminals 8 and 11 of the drive terminal block

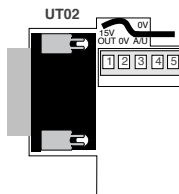

- The drive is disabled (terminal 31 not supplied).
- The run command has not been enabled.

Switch on the drive

- The drive status is "Inh" or "Enc x" depending on how the speed feedback is configured
- If the drive trips, apart from "Enc x", refer to section K of the Unidrive SP manual 3616.

Select the control mode

- **0.00** : Enter 1253 in European configuration.
 - **0.48** : Select ServO mode then press the Reset key (⊖).
- (If a drive trip "Enc x" occurs, continue with the procedure).

Enter the motor parameters indicated on the motor nameplate

- **0.44** : Motor rated voltage.
- **0.46** : Motor rated current.
- **5.08** : Motor rated speed.

Enter the other motor parameters

- **0.02** : Max. speed < 140% of the motor rated speed **5.08**.
- **0.06** : Symmetrical current limiting = 150%.
- **0.41** : The SWITCHING FREQUENCY value must be set according to the following table:
- **0.42** : Number of poles (calculation: $p = 120f / n$).
- **0.45** : Motor thermal constant = 89.
- **5.22** : Enable high speed = ON.

5.08 (Motor rated speed)	0.41 (Switching frequency)
N.rated ≤ 1800 rpm	3 kHz
1800 rpm < N.rated ≤ 3600 rpm	4 kHz
3600 rpm < N.rated	6 kHz

- ⚠ Before setting the maximum speed, check that the motor and the machine can withstand it.
- Respect the supply voltage "Inverter supply" indicated on the motor nameplate.

- **5.35** : Disabling of the automatic switching frequency adjustment = On (1).

Enter the characteristics of the Hall effect sensor

- **3.34** : Drive encoder lines per revolution = 0.
- **3.36** : Supply voltage = 15V.
- **3.38** : Type = AB servo.
- **3.39** : Impedance matching = 0.
- Clear the "Enc x" trip with a reset if necessary.

Preset the control parameters

- **0.03** : Acceleration rate = 3.
- **0.04** : Deceleration rate = 5.
- **6.01** : Type of stop = rp.
- **6.08** : Standstill torque = 0.

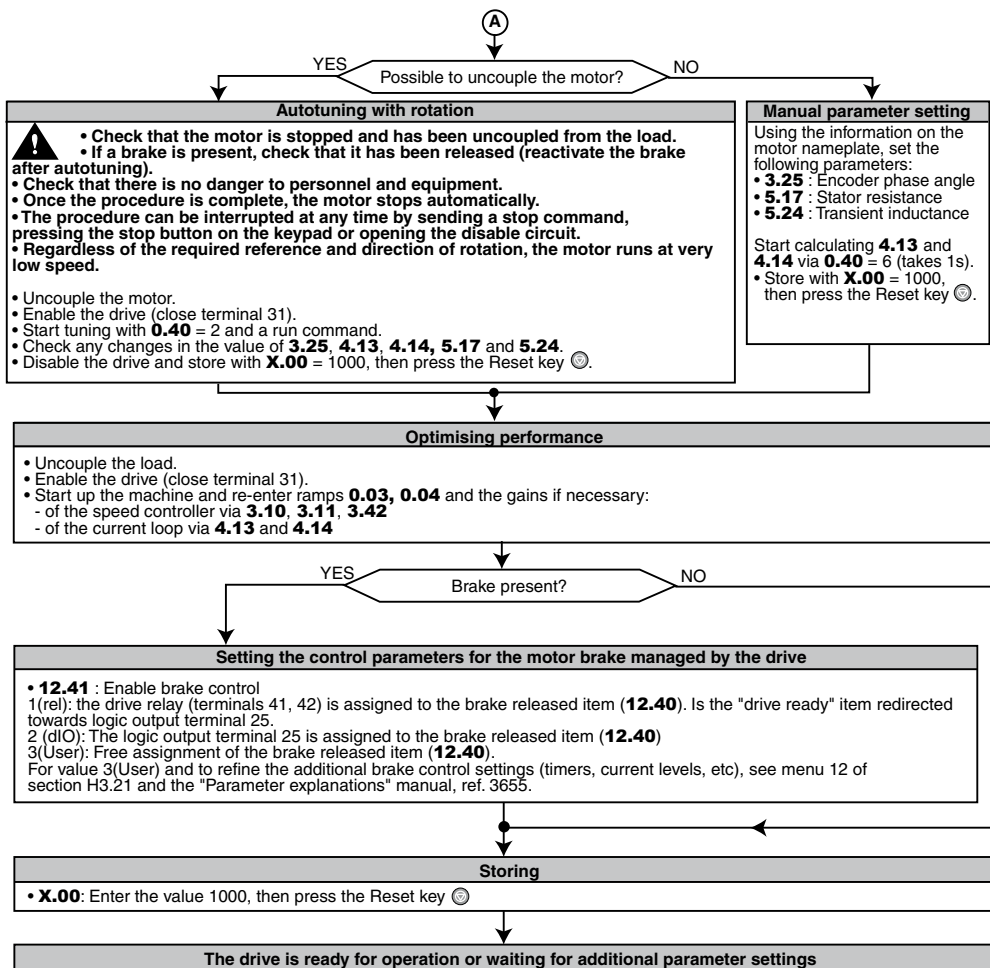

DYNEO®**Synchronous motors with permanent magnets-drive**

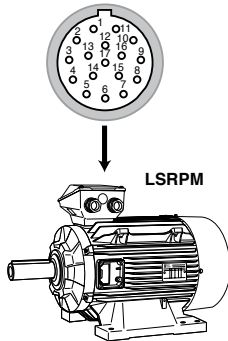
DYNEO®**Synchronous motors with permanent magnets-drive****3 - COMMISSIONING OF LSRPM MAGNETS MOTOR WITH FEEDBACK VIA ENCODER WITH COMMUTATION CHANNELS, CONTROLLED BY A UNIDRIVE SP DRIVE****3.1 - Connecting the sensor on the motor end (standard)**

17-pin connector on encoder end (male plug)		15-pin connector on drive end
No.	Designation	No.
1	x	x
2	x	x
3	x	x
4	U or S1	7
5	U\ or S1\	8
6	V or S2	9
7	V\ or S2\	10
8	W or S3	11
9	W\ or S3\	12
10	A	1
11	C or O or Z	5
12	C\ or O\ or Z\	6
13	A\	2
14	B	3
15	B\	4
16	+5V or +15V	13
17	0V	14
	Shielding (2)	(3)

Use shielded cable on each pair. The thermal sensor is connected in the motor terminal box (1)

- (1) The thermal sensor connected in the motor terminal box should be connected to terminals 8 and 11 of the drive control terminal block. To modify sensor control, see parameter **7.15 (0.21)**.
- (2) Connect the shielding 360° round the connector.
- (3) Connect the shielding 360° round the shielding connection holder.

3.2 - Simplified commissioning with UNIDRIVE SP drive**Drive off, check that ...**

- The order of the motor phases is respected
- The encoder wiring conforms to section F1.2 of drive manual 3616
- The drive is disabled (terminal 31 not supplied).
- The run command has not been enabled
- For information, the standard encoder feedback of LSRPM is a 5V, 1024 ppr sensor.

Switch on the drive

- The drive status is "inh" or "Enc x" depending on how the speed feedback is configured
- If the drive trips, apart from "Enc x", refer to the diagnostics section of the drive manual

Select the control mode

- **0.00** enter 1253 in European configuration
- **0.48** select SerVO mode then press the Reset key ☺

Enter the motor parameters indicated on the motor nameplate

- **0.44** : Motor rated voltage
- **0.46** : Motor rated current
- **5.08** : Motor rated speed



DYNEO[®]

Synchronous motors with permanent magnets-drive

A

Enter the other motor parameters

- **0.02** : Max. speed < 140% of the motor rated speed **5.08**.
- **0.06** : Symmetrical current limiting = 150%.
- **0.41** : The SWITCHING FREQUENCY value must be set according to the following table:
- **0.42** : Number of poles (calculation: $p = 120f / n$).
- **0.45** : Motor thermal constant = 89.
- **5.22** : Enable high speed = ON.

5.08 (Motor rated speed)	0.41 (Switching frequency)
$N_{\text{rated}} \leq 1800$ rpm	3 kHz
$1800 \text{ rpm} < N_{\text{rated}} \leq 3600$ rpm	4 kHz
$3600 \text{ rpm} < N_{\text{rated}}$	6 kHz

- ⚠** • Before setting the maximum speed, check that the motor and the machine can withstand it.
• Respect the supply voltage "Inverter supply" indicated on the motor nameplate.

- **5.35** : Disabling of the automatic switching frequency adjustment = On (1).

Enter the characteristics of the incremental encoder

- **3.34** : Drive encoder lines per revolution
- **3.36** : Encoder supply voltage
- **3.38** : Type = AB servo
- Clear the "Enc x" trip with a reset if necessary

Preset the control parameters

- **0.03** : Acceleration rate = 3
- **0.04** : Deceleration rate = 5
- **6.01** : Type of stop = rp
- **6.08** : Standstill torque = 0

YES Possible to uncouple the motor? NO

Autotuning with rotation

- ⚠** • Check that the motor is stopped and has been uncoupled from the load.
• If a brake is present, check that it has been released (reactivate the brake after autotuning).
- Check that there is no danger to personnel and equipment.
 - Once the procedure is complete, the motor stops automatically.
 - The procedure can be interrupted at any time by sending a stop command, pressing the stop button on the keypad or opening the disable circuit.
 - Regardless of the required reference and direction of rotation, the motor runs at very low speed.

- Uncouple the motor.
- Enable the drive (close terminal 31).
- Start autotuning with **0.40** = 2 and a run command
- Check any changes in the value of **3.25**, **4.13**, **4.14**, **5.17**, **5.24**.
- Disable the drive and store with **X.00** = 1000, then press the Reset key 

Manual parameter setting

Using the information on the motor nameplate, set the following parameters:

- **3.25** : Encoder phase angle
- **5.17** : Stator resistance
- **5.24** : Transient inductance

Start calculating **4.13** and **4.14** via **0.40** = 6 (takes 1s).
• Store with **X.00** = 1000, then press the Reset key .

Optimising performance

- Couple the load.
- Enable the drive (close terminal 31).
- Start up the machine and re-enter ramps **0.03**, **0.04** and the gains if necessary:
 - of the speed controller via **3.10**, **3.11**, **3.42**
 - of the current loop via **4.13** and **4.14**

YES Brake present? NO

Setting the control parameters for the motor brake managed by the drive

- **12.41** : Enable brake control
 - 1 (rel): The drive relay (terminals 41, 42) is assigned to the brake released item (**12.40**). The "drive ready" item is then redirected towards logic output terminal 25.
 - 2 (dIO): The logic output terminal 25 is assigned to the brake released item (**12.40**).
 - 3 (User): Free assignment of the brake released item (**12.40**).
- For value 3 (User) and to refine the additional brake control settings (time delays, current levels, etc), see menu 12 of section H3.21 of manual ref. 3616 and the "Parameter explanations" manual, ref. 3655.

Storing

- **X.00**: Enter the value 1000, then press the Reset key 

The drive is ready to operate, or waiting for additional parameter settings

DYNEO®**Synchronous motors with permanent magnets-drive****4 - COMMISSIONING FOR CONTROL OF AN LSRPM MOTOR IN «SENSORLESS» MODE (PARAMETER 00.14)****Drive off, check that:**

- Terminals SDI1 and SDI2 are connected in order to run the power self-test (see **17.03**).
- The run command has not been enabled.
- The motor is connected.

Switch on the drive

- In read mode, the operating status displays "DISABLED".
- If the drive trips, refer to section 7 "TRIPS – DIAGNOSTICS" in the manual ref.3871.

Select the control mode

- In parameter setting mode, select "Basic set up".
- Return to factory setting **00.45** = 50 Hz High or Low for a 400V/50Hz supply, or 60 Hz High or Low for a 460V/60Hz supply (**00.45** automatically returns to DISABLED after few seconds).
- Enter **00.13** = SERVO and **00.14** = SENSORLESS 2.

Enter the main parameters

- **00.02**: MAXIMUM SPEED (in rpm).
 - **00.03** and **00.04**: ACCELERATION RATE 1 and DECELERATION RATE 1 (in sec for 1000 rpm, factory setting).
 - Connect the motor thermistor to the drive terminal block (ADI3/0V terminals), and set **00.28** = CTP (1).
- !** Before setting the maximum speed, check that the motor and the machine can withstand it.
• Respect the supply voltage "Inverter supply" indicated on the motor nameplate.

Motor parameters to be taken from the nameplate

- **00.06**: MOTOR RATED CURRENT (A).
- **00.07**: MOTOR RATED SPEED (rpm).
- **00.08**: MOTOR RATED VOLTAGE (V).
- **00.10**: MOTOR RATED FREQUENCY (Hz).
- **05.24**: Enter 80% of plated transient inductance Ld.
- **05.33**: Enter EMF at 1000 rpm (plated).

Set the other control parameters

- **00.12** : The SWITCHING FREQUENCY value must be set according to the following table :

00.07 (motor rated speed)	00.12 (Switching frequency)
N.rated ≤ 1800 rpm	3 kHz
1800 rpm < N.rated ≤ 2400 rpm	4 kHz
2400 rpm < N.rated ≤ 3600 rpm	4,5 kHz
3600 rpm < N.rated ≤ 4500 rpm	5 kHz
4500 rpm < N.rated	6 kHz

- **00.21** : CURRENT LOOP PROPORTIONAL GAIN = $\kappa \times \text{kVA} \times \text{Ld}$
with:
- κ = 1 for 400/460V drives,
- kVA : Drive rating (example : 340 for a 340T),
- Ld : inductance value located on the motor nameplate in mH.

We advise that the gain value should not be greater than 80 when the stator frequency is lower than 150 Hz.

The drive is ready to operate or waiting for additional parameter settings.

DYNEO®**Synchronous motors with permanent magnets-drive****5 - CONNECTIONS****5.1 - Motors**

Frame size ≤ 160

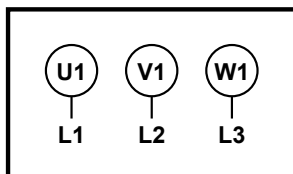

Frame size > 160

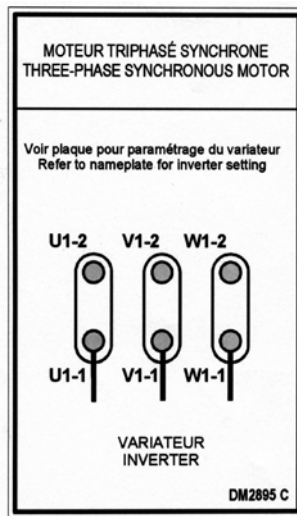
**5.2 - Hall effect sensor**

1 2 3 4 5 6 7 8 9 10 11

**CONNECTION DIAGRAM FOR WAGO 261
 TERMINAL BLOCK INSIDE TERMINAL BOX**
 Terminal marking

1 2 3 4 5 6 7 8 9 10 11

- 1 = U } green
 2 = W }
 3 = V } yellow
 4 = U }
 5 = W } grey
 6 = V }
 7 = 0V - white
 8 = +15V - brown
 9 = shielding
 10/11 = PTC

DM2909

DYNEO®

Synchronous motors with permanent magnets-drive

5.3 - Incremental encoder with UVW commutation channels

Function	U	U/	V	V/	W	W/	A	Z	Z/	A/	B	B/	VDC	Gnd
Wire	White-Green	White-Pink	White-Yellow	White-Blue	White-Grey	White-Brown	Green	Grey	Red	Pink	Yellow	Blue	Brown	White
M23 17-pin	4	5	6	7	8	9	10	11	12	13	14	15	16	17

Pins 1 to 3 are not connected. The cable general shielding is connected to the connector casing

5.4 - Forced ventilation

<p>230 or 400 V SINGLE-PHASE FORCED VENTILATION for frame size ≤ 132</p>	<p>3-PHASE FORCED VENTILATION* for frame size > 132</p>												
<table border="1" style="margin-left: auto; margin-right: auto;"> <thead> <tr> <th colspan="3">Capacitors</th> </tr> <tr> <th>Motor type</th> <th>CP1</th> <th>CP2</th> </tr> </thead> <tbody> <tr> <td>LS 80</td> <td>1.5 mf</td> <td>1.5 mf</td> </tr> <tr> <td>LS 90 to 132</td> <td>3 mf</td> <td>2 mf</td> </tr> </tbody> </table> <p>U = 230 V ~ Power supply on U and W U = 400 V ~ Power supply on V and W</p>	Capacitors			Motor type	CP1	CP2	LS 80	1.5 mf	1.5 mf	LS 90 to 132	3 mf	2 mf	<p>1 SPEED - 2 VOLTAGES</p> <p>↻ L1 - L2 - L3</p> <div style="display: flex; justify-content: space-around;"> <div style="text-align: center;"> <p>Δ 230 V</p> </div> <div style="text-align: center;"> <p>Y 400 V</p> </div> </div>
Capacitors													
Motor type	CP1	CP2											
LS 80	1.5 mf	1.5 mf											
LS 90 to 132	3 mf	2 mf											

*for 4500 et 5500 rpm, contact the factory

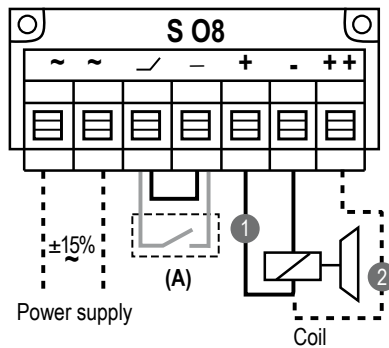
DYNEO®**Synchronous motors with permanent magnets-drive****5.5 - Brake**

Power supply	Coil	Wiring*
400 VAC	180 VDC	①
230 VAC	180 VDC	②

*depending on power supply and coil

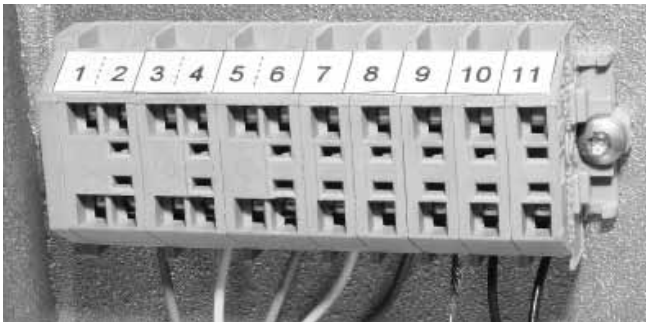
5.6 - PTC sensors

Connection of PTC sensors
Terminal numbers: 10 and 11

DYNEO®**Synchronous motors with permanent magnets-drive**

DYNEO®**Synchronous motors with permanent magnets-drive**

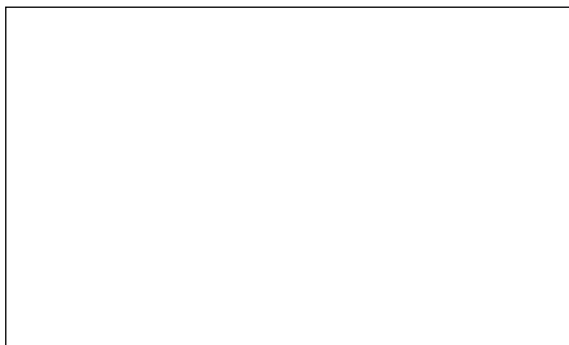

MOTEURS LEROY-SOMER 16015 ANGOULÊME CEDEX - FRANCE

338 567 258 RCS ANGOULÊME
S.A. au capital de 62 779 000 €

www.leroy-somer.com