



User Guide

Modbus TCP Module For use with Digistart D2 and D3

Part Number: 5107 en - 2017.12 / d

General Information

The manufacturer accepts no liability for any consequences resulting from inappropriate, negligent or incorrect installation or adjustment of the optional parameters of the equipment or from mismatching the starter with the motor.

The contents of this guide are believed to be correct at the time of printing. In the interests of commitment to a policy of continuous development and improvement, the manufacturer reserves the right to change the specification of the product or its performance, or the content of the guide without notice.

All rights reserved. No parts of this guide may be reproduced or transmitted in any form or by any means, electrical or mechanical including, photocopying, recording or by an information storage or retrieval system, without permission in writing from the publisher.

Contents

1. Important User Information	4
1.1 Safety	4
1.2 Product Design	4
1.3 Compatibility	4
1.4 Disclaimer	4
2. Installation	5
2.1 Installation Procedure	5
3. Connection.....	6
3.1 Soft Starter Connection.....	6
3.2 Network Connection.....	6
3.3 Network Establishment	7
3.4 Addressing.....	7
4. Device Configuration	8
4.1 On-board Web Server	8
4.2 Ethernet Device Configuration Tool	9
5. Operation	10
5.1 Device Classification	10
5.2 Configuration	10
5.3 LEDs.....	10
6. Modbus Registers	11
6.1 Compatibility	11
6.2 Ensuring Safe and Successful Control.....	11
6.3 Configuring Soft Starter Parameters	11
6.4 Standard Mode	12
6.5 Legacy Mode	17
6.6 Trip Codes	21
7. Network Design	23
7.1 Star Topology	23
7.2 Line Topology	23
7.3 Ring Topology.....	24
7.4 Combined Topologies	24
8. Specifications	25

1. Important User Information

1.1 Safety

Observe all necessary safety precautions when controlling the soft starter remotely. Alert personnel that machinery may start without warning.

It is the installer's responsibility to follow all instructions in this manual and to follow correct electrical practice.

Close attention is required to the electrical installation and the system design to avoid hazards either in normal operation or in the event of equipment malfunction. System design, installation, commissioning and maintenance must be carried out by personnel who have the necessary training and experience. They must read this safety information and this guide carefully.

1.2 Product Design

The Modbus TCP Module allows a Nidec soft starter to connect to an Ethernet network and be controlled or monitored using an Ethernet communication model.

Separate modules are available for Profinet, Modbus TCP and Ethernet/IP networks.

The Modbus TCP Module operates at the application layer. Lower levels are transparent to the user.

This document describes use of the Modbus TCP Module with compatible Nidec soft starters.

Familiarity with Ethernet protocols and networks is required to operate the Modbus TCP Module successfully. For difficulties using this device with third party products, including PLCs, scanners and commissioning tools, contact the relevant supplier.

1.3 Compatibility

The Modbus TCP Module is compatible with the following Nidec soft starters:

- Digistart D2 – 110/240 Vac control voltage.
The Modbus TCP Module is not suitable for use with Digistart D2 starters using 380/440 Vac control voltage.
- Digistart D3 – all models.

1.4 Disclaimer

The examples and diagrams in this manual are included solely for illustrative purposes. The information contained in this manual is subject to change at any time and without prior notice. In no event will responsibility or liability be accepted for direct, indirect or consequential damages resulting from the use or application of this equipment.

2. Installation



Remove mains and control voltage from the soft starter before attaching or removing accessories. Failure to do so may damage the equipment.

2.1 Installation Procedure

1. Remove control power and mains supply from the soft starter.
2. Fully pull out the top and bottom retaining clips on the module.
3. Line up the module with the comms port slot.
4. Push in the top and bottom retaining clips to secure the module to the starter.
5. Insert the network connector.
6. Apply control power to the soft starter.

Figure 2-1 Attach the module to the starter

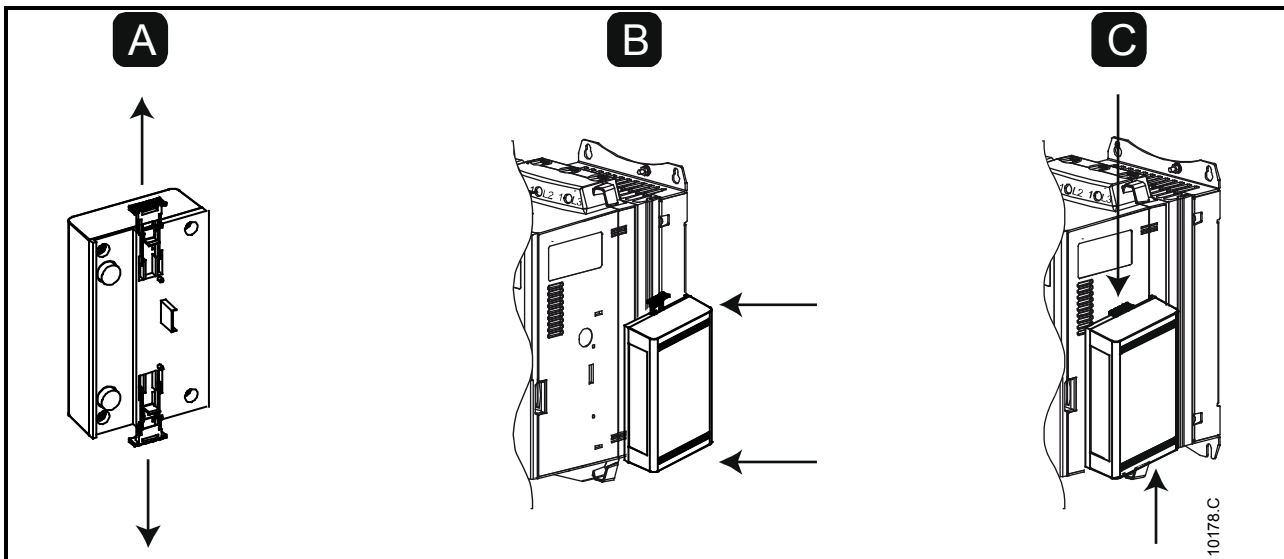
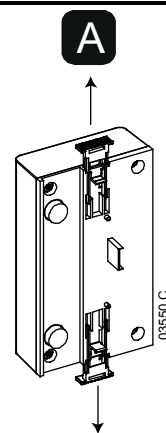

Figure 2-2 Remove the module from the starter

Remove the module using the following procedure:

1. Remove control power and mains supply from the soft starter.
2. Disconnect all external wiring from the module.
3. Fully pull out the top and bottom retaining clips on the module.
4. Pull the module away from the soft starter.



3. Connection

3.1 Soft Starter Connection

The Modbus TCP Module is powered from the soft starter.

Digistart D2: For the Modbus TCP Module to accept fieldbus commands, a link must be fitted across terminals CSL-DI2 on the soft starter.

The Modbus TCP Module is not suitable for use with Digistart D2 starters using 380/440 Vac control voltage.

Digistart D3: Input links are required across the stop and reset inputs if the soft starter is being operated in Remote mode. In Local mode, links are not required.

NOTE Digistart D3: Control via the fieldbus communication network is always enabled in local control mode, and can be enabled or disabled in remote control mode (Pr **30 Comms in Remote**). See the soft starter user manual for parameter details.

Figure 3-1 Modbus TCP Module connections

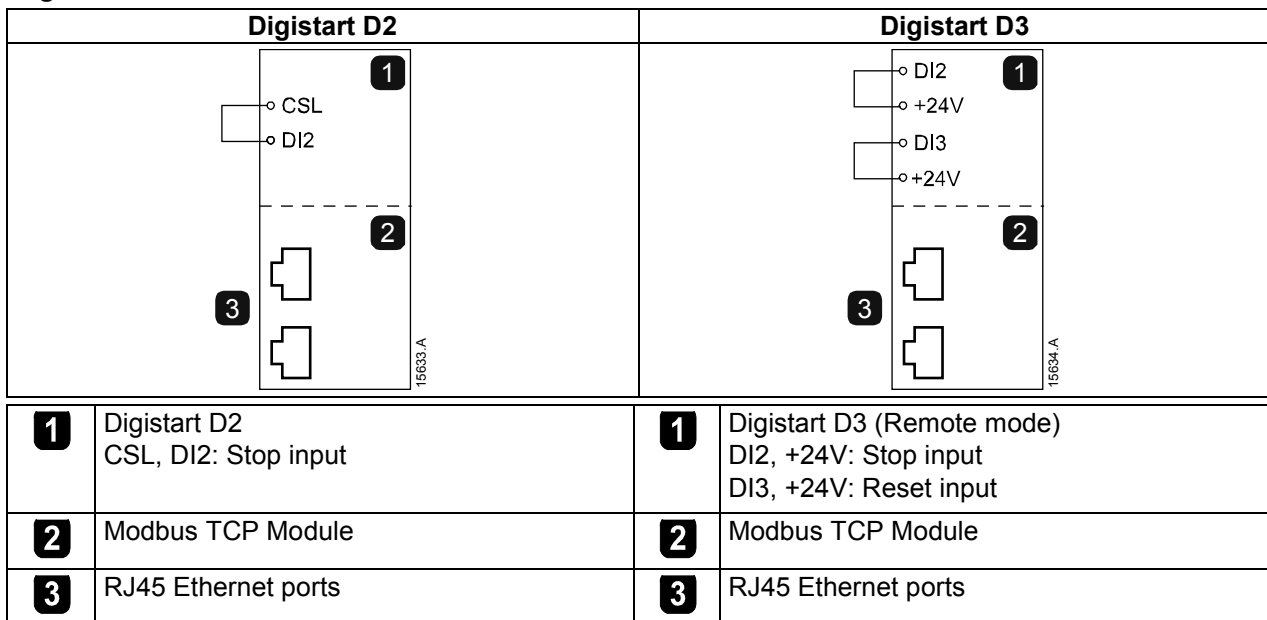

3.2 Network Connection

3.2.1 Ethernet Ports

The Modbus TCP Module has two Ethernet ports. The ports are equal and interchangeable - if only one connection is required, either port can be used.

3.2.2 Cables

Use Category 5, 5e, 6 or 6e cable to connect to the Modbus TCP Module.

3.2.3 EMC Precautions

To minimise electromagnetic interference, Ethernet cables should be separated from motor and mains cables by 200 mm.

If the Ethernet cable must cross motor or mains cables, the crossing should be at an angle of 90°.

3.3 Network Establishment

The controller must establish communications directly with each module before the module can participate in the network. Once communications are established, the module can participate in an existing network.

3.4 Addressing

Each device in a network is addressed using a MAC address and an IP address, and can be assigned a symbolic name associated with the MAC address.

- The module will receive a dynamic IP address (via DHCP) when it is connected to the network, or can be assigned a static IP address during configuration.
- The symbolic name is optional and must be configured within the device.
- The MAC address is fixed within the device and is printed on a label on the front of the module.

Figure 3-2 MAC ID location

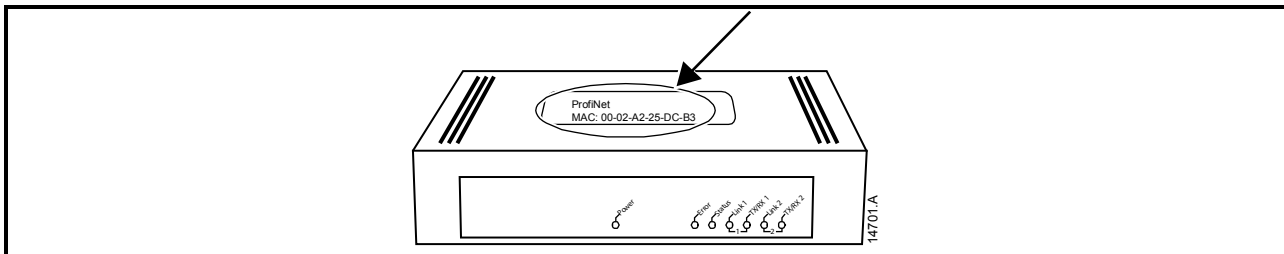

4. Device Configuration

NOTE The Error LED flashes whenever the module is receiving power but is not connected to a network. The Error LED will flash throughout the configuration process.

4.1 On-board Web Server

Ethernet attributes can be configured directly in the Modbus TCP Module using the on-board web server.

NOTE The default address for a new Modbus TCP Module is 192.168.0.1. The default subnet mask is 255.255.255.0. The web server will only accept connections from within the same subnet domain. Use the Ethernet Device Configuration Tool to temporarily change the network address of the module to match the network address of the PC running the tool, if required.

To configure the device using the on-board web server:

1. Attach the module to a soft starter.
2. Connect one Ethernet port on the module to the Ethernet port of the PC.
3. Apply control power to the soft starter.
4. Start a browser on the PC and enter the device address, followed by /ipconfig.
The default address for a new Modbus TCP Module is 192.168.0.1.

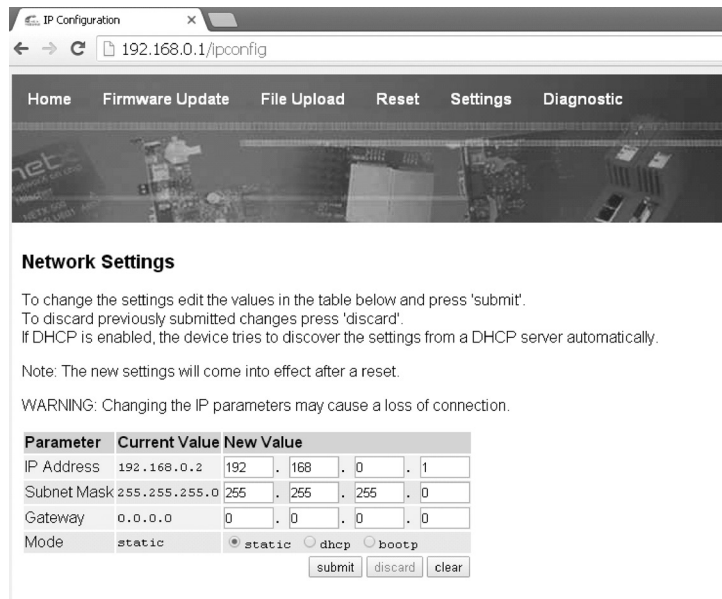

The screenshot shows a web browser window titled "IP Configuration" with the address bar set to "192.168.0.1/ipconfig". The page has a navigation menu with "Home", "Firmware Update", "File Upload", "Reset", "Settings", and "Diagnostic". Below the menu is a banner image of a network switch. The main content area is titled "Network Settings" and contains instructions: "To change the settings edit the values in the table below and press 'submit'. To discard previously submitted changes press 'discard'. If DHCP is enabled, the device tries to discover the settings from a DHCP server automatically. Note: The new settings will come into effect after a reset. WARNING: Changing the IP parameters may cause a loss of connection." Below this is a table for configuration:

Parameter	Current Value	New Value
IP Address	192.168.0.2	192 . 168 . 0 . 1
Subnet Mask	255.255.255.0	255 . 255 . 255 . 0
Gateway	0.0.0.0	0 . 0 . 0 . 0
Mode	static	<input checked="" type="radio"/> static <input type="radio"/> dhcp <input type="radio"/> bootp

At the bottom of the form are "submit", "discard", and "clear" buttons. A vertical label "15622.B" is on the right side of the screenshot.

5. Edit the settings as required. Click "Submit" to save the new settings. To store the settings permanently in the module, tick "Static".
6. If prompted to enter a username and password:
username: aucom
password: aucom

NOTE If you change the IP address and lose your record of it, use the Ethernet Device Configuration Tool to scan the network and identify the module.

NOTE If you change the subnet mask, the web server will not be able to communicate with the module after the new settings are saved to the module.

4.2 Ethernet Device Configuration Tool

The Ethernet Device Configuration Tool can be downloaded from www.nidec.com.

To permanently configure attributes in the Modbus TCP Module, use the on-board web server. Changes made via the Ethernet Device Configuration Tool cannot be stored permanently in the Modbus TCP Module.

To configure the device using the Ethernet Device Configuration Tool:

1. Attach the module to a soft starter.
2. Connect one Ethernet port on the module to the Ethernet port of the PC.
3. Apply control power to the soft starter.
4. Start the Ethernet Device Configuration Tool.

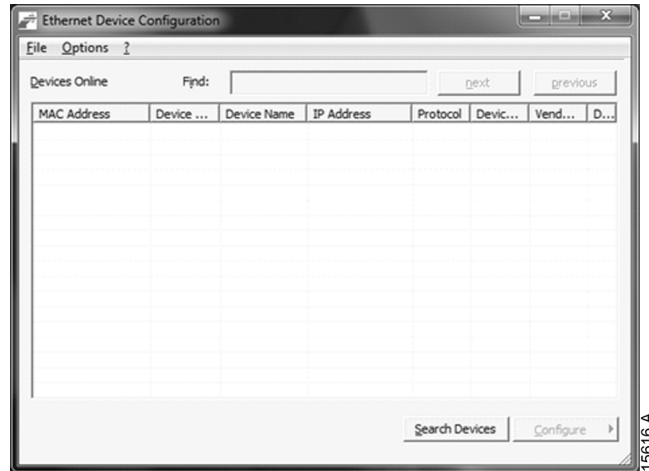

5. Click on Search Devices. The software will search for connected devices.

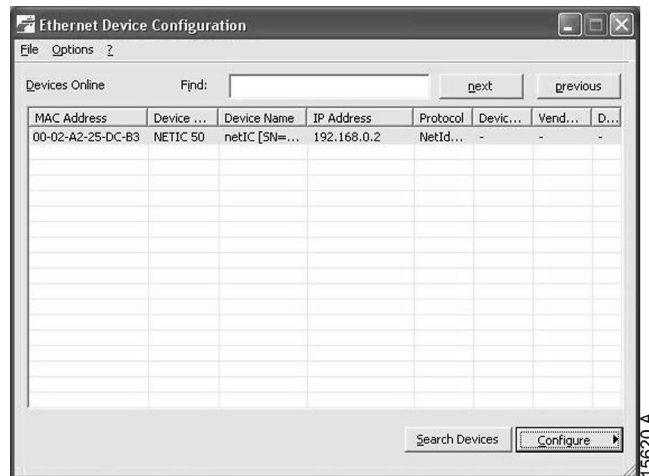

6. To set a static IP address, click Configure then select Set IP address.

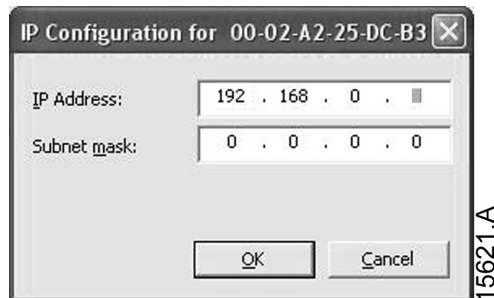

5. Operation

The Modbus TCP Module must be controlled by a Modbus client (such as a PLC) which complies with the Modbus Protocol Specification. For successful operation, the client must also support all functions and interfaces described in this document.

5.1 Device Classification

The Modbus TCP Module is a Modbus server and must be managed by a Modbus client over Ethernet.

5.2 Configuration

The Modbus TCP Module must be configured directly in the PLC. No additional files are required.

5.3 LEDs

Figure 5-1 Feedback LEDs

LED name	LED Status	Description
Power	Off	Module is not powered up.
	On	Module is receiving power.
Error	Off	No error.
	Flashing	System error.
	On	Communication error.
Status	Off	Not ready.
	Slow flash	Ready but not configured.
	Fast flash	Configured and waiting for communication.
	On	Communication has been established.
Link x	Off	No network connection.
	On	Connected to a network.
TX/RX x	Flashing	Establishing connection.
	On	Operating normally.

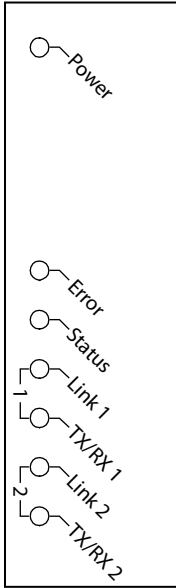

14702A

6. Modbus Registers

NOTE All references to registers mean the registers within the module unless otherwise stated.

6.1 Compatibility

The Modbus TCP Module supports two modes of operation.

- In Standard Mode, the module uses registers defined in the Modbus Protocol Specification.
- In Legacy Mode, the module uses the same registers as Nidec's Modbus Module. Some registers differ from those specified in the Modbus Protocol Specification.

The mode of operation is determined by the values of bit 15 in register 40001.

- Standard Mode: set Bit 15 = 1. Bits 0 to 7 of register 40001 are used for command.
- Legacy Mode: set Bit 15 = 0. The remaining bits of register 40001 are reserved.

Examples

10000000 00000001 = start the motor (Standard Mode).

10000000 00000000 = stop the motor (Standard Mode).

00000000 xxxxxxxx = switch to Legacy Mode. The module will ignore the remaining bits in register 40001 and will check the value in register 40002.

6.2 Ensuring Safe and Successful Control

Data written to the Modbus TCP Module will remain in its registers until the data is overwritten or the module is reinitialised. The Modbus TCP Module will not transfer successive duplicate commands to the soft starter.

NOTE If the soft starter is started via fieldbus communications but stopped via the keypad or a remote input, an identical start command cannot be used to restart the starter.

In order to operate safely and successfully in an environment where the soft starter may also be controlled via the keypad or the remote inputs (as well as via fieldbus communications), a control command should be immediately followed by a status query to confirm the command has been actioned.

6.3 Configuring Soft Starter Parameters

Parameter management is always multiple write of the entire parameter block.

When configuring parameters in the soft starter, the PLC must be programmed with the correct values for all parameters. The Modbus TCP Module will update every parameter in the starter to match the values in the PLC.

6.4 Standard Mode

6.4.1 PLC Configuration

The PLC must be configured to map registers within the module to addresses within the PLC.

Figure 6-1 Example mapping of PLC registers to registers within the Modbus TCP Module (Target):

Index	Register	Type	Dev Name	ID	Target	Length	Trigger
0	%R00090	T->	deno	192.168.0.1(2)	40001	1	%T00001
1	%R00110	<--	deno	192.168.0.1(2)	30240	4	None
2	%R00120	<--	deno	192.168.0.1(2)	30250	8	None
3	%R00128	<--	deno	192.168.0.1(2)	30258	9	None
4	%R00137	<--	deno	192.168.0.1(2)	30267	1	None
5	%R00300	<--	deno	192.168.0.1(2)	40009	4	None
6	%R00400	<--	deno	192.168.0.1(2)	30300	5	None

6.4.2 Command and Configuration Register Addresses (Read/Write)

Table 6-1 Command and configuration register addresses

Register Address	Description	Bits	Details
40001	Command (single write)	0 to 7	To send a command to the starter, write the required value in binary: 00000000 = Stop 00000001 = Start 00000010 = Reset 00000100 = Quick stop (coast to stop) 00001000 = Force trip 00010000 = Start using Parameter Set 1 ¹ 00100000 = Start using Parameter Set 2 ¹ 01000000 = Local mode 10000000 = Remote mode
		8 to 14	Reserved
		15	Must = 1
40002	Reserved	0 to 7	Must be zero
40003	Reserved	0 to 7	
40004	Reserved	0 to 7	
40005	Reserved	0 to 7	
40006	Reserved	0 to 7	
40007	Reserved	0 to 7	
40008	Reserved	0 to 7	
40009 ² to 40XXX	Parameter management (single/multiple read or multiple write)	0 to 7	Manage soft starter programmable parameters

¹ Ensure that the programmable input is not set to Motor Set Select before using this function.

² See the relevant soft starter literature for a complete parameter list. The first product parameter is always allocated to register 40009. The last product parameter is allocated to register 40XXX, where XXX = 008 plus total number of available parameters in the product.

6.4.3 Status Reporting Register Addresses (Read Only)

NOTE Some soft starters do not support some functions.

The following functions are only available with Digistart D3 soft starters:
parameter management, dual motor control, digital inputs, jog, current measurement in amperes, power information, warnings.

Table 6-2 Status reporting register addresses

Register Address	Description	Bits	Details
30240	Starter state	0 to 3	1 = Ready 2 = Starting 3 = Running 4 = Stopping (including braking) 5 = Restart delay (including temperature check) 6 = Tripped 7 = Programming mode 8 = Jog forward 9 = Jog reverse
		4	1 = Positive phase sequence (only valid if bit 6 = 1)
		5	1 = Current exceeds FLC
		6	0 = Unintialised 1 = Initialised
		7	<i>Reserved</i>
30241	Trip code	0 to 7	See Trip Codes on page 21
30242 ¹	Motor current	0 to 7	Average 3-phase motor current (A)
30243	Motor temperature	0 to 7	Motor 1 thermal model (%)
30244 to 30249	<i>Reserved</i>		
30250	Version	0 to 5	<i>Reserved</i>
		6 to 8	Product parameter list version
		9 to 15	Product type code ²
30251	Device details		
30252 ³	Changed parameter number	0 to 7	0 = No parameters have changed 1 to 255 = Index number of the last parameter changed
		8 to 15	Total number of parameters available in the starter
30253 ³	Changed parameter value	0 to 13	Value of the last parameter that was changed, as indicated in register 30252
		14 to 15	<i>Reserved</i>

Register Address	Description	Bits	Details
30254	Starter state	0 to 4	0 = <i>Reserved</i> 1 = Ready 2 = Starting 3 = Running 4 = Stopping 5 = Not ready (restart delay, restart temperature check, run simulation, input A (DI4, +24V) not shorted) 6 = Tripped 7 = Programming mode 8 = Jog forward 9 = Jog reverse
		5	1 = Warning
		6	0 = Uninitialised 1 = Initialised
		7	0 = Local control 1 = Remote control
		8	0 = Parameter(s) have changed since last parameter read 1 = No parameters have changed ³
		9	0 = Negative phase sequence 1 = Positive phase sequence
		10 to 15	See Trip Codes on page 21 ⁴
30255 ¹	Current	0 to 13 14 to 15	Average rms current across all three phases <i>Reserved</i>
30256	Current	0 to 9 10 to 15	Current (% motor FLC) <i>Reserved</i>
30257	Motor temperature	0 to 7	Motor 1 thermal model (%)
		8 to 15	Motor 2 thermal model (%)
30258 ⁵	Power	0 to 11	Power
		12 to 13	Power scale
		14 to 15	<i>Reserved</i>
30259	% Power factor	0 to 7	100% = power factor of 1
		8 to 15	<i>Reserved</i>
30260	<i>Reserved</i>		
30261 ¹	Current	0 to 13	Phase 1 current (rms)
		14 to 15	<i>Reserved</i>
30262 ¹	Current	0 to 13	Phase 2 current (rms)
		14 to 15	<i>Reserved</i>
30263 ¹	Current	0 to 13	Phase 3 current (rms)
		14 to 15	<i>Reserved</i>
30264	<i>Reserved</i>		
30265	<i>Reserved</i>		
30266	<i>Reserved</i>		
30267	Parameter list version number	0 to 7	Parameter list minor revision
		8 to 15	Parameter list major version

Register Address	Description	Bits	Details
30268	Digital Input state	0 to 15	For all inputs, 0 = open, 1 = closed (shorted) 0 = Start 1 = Stop 2 = Reset 3 = Input A 4 = Input B 5 = Input C, if fitted 6 = Input D, if fitted 7 to 15 = <i>Reserved</i>
30269 to 30281	<i>Reserved</i>		
30300	Product information	0 to 2	Parameter list version number
		3 to 7	Product type code ²
30301 to 30303	<i>Reserved</i>		
30304	MAC ID	0 to 15	

¹ For models D3-1x-0053-B and smaller this value will be 10 times greater than the value displayed on the keypad.

² Product type code:

4 = Digistart D2

8 = Digistart D3

³ Reading register 30253 (Changed parameter value) will reset registers 30252 (Changed parameter number) and 30254 (Parameters have changed). Always read registers 30252 and 30254 before reading register 30253.

⁴ Bits 10 to 15 of register 30254 report the soft starter's trip or warning code. If the value of bits 0 to 4 is 6, the soft starter has tripped. If bit 5 = 1, a warning has activated and the starter is continuing to operate.

⁵ Powerscale functions as follows:

0 = multiply Power by 10 to get W

1 = multiply Power by 100 to get W

2 = Power is represented in kW

3 = multiply Power by 10 to get kW

6.4.4 Examples

Figure 6-2 Send start command (register 40001)

The screenshot shows the 'Data Mapping' dialog box with the following settings:

- Target:** Device Name: deno [192.168.0.1(2)], Device Register: 40001, Length: 1, 32-bit access: unchecked.
- Local:** Register: %R00090, Name: (empty).
- Update Type:** Polled Read, Triggered Read, Polled Read/Write, Triggered Write (selected), Polled Read/Write Init, Trigger Register: %T00001.

Buttons: OK, Cancel. Vertical text on the right: 15629.A

Figure 6-3 Get status (starting at address 30240)

The screenshot shows the 'Data Mapping' dialog box with the following settings:

- Target:** Device Name: deno [192.168.0.1(2)], Device Register: 30240, Length: 4, 32-bit access: unchecked.
- Local:** Register: %R00110, Name: (empty).
- Update Type:** Polled Read (selected), Triggered Read, Polled Read/Write, Triggered Write, Polled Read/Write Init, Trigger Register: (empty).

Buttons: OK, Cancel. Vertical text on the right: 15630.A

Figure 6-4 Get parameter values (starting at register 40009)

The screenshot shows the 'Data Mapping' dialog box with the following settings:

- Target:** Device Name: deno [192.168.0.1(2)], Device Register: 40009, Length: 4, 32-bit access: unchecked.
- Local:** Register: %R00300, Name: (empty).
- Update Type:** Polled Read (selected), Triggered Read, Polled Read/Write, Triggered Write, Polled Read/Write Init, Trigger Register: (empty).

Buttons: OK, Cancel. Vertical text on the right: 15627.A

6.5 Legacy Mode

6.5.1 PLC Configuration

The PLC must be configured to map registers within the module to addresses within the PLC.

Figure 6-5 Example mapping of PLC registers to registers within the Modbus TCP Module (Target):

Index	Register	Type	Dev Name	ID	Target	Length	Trigger
0	%R00090	T->	deno	192.168.0.1(2)	40002	1	%T00001
1	%R00110	<-	deno	192.168.0.1(2)	40003	4	None
2	%R00120	<-	deno	192.168.0.1(2)	40600	8	None
3	%R00128	<-	deno	192.168.0.1(2)	40608	9	None
4	%R00137	<-	deno	192.168.0.1(2)	40617	1	None
5	%R00300	<-	deno	192.168.0.1(2)	40009	4	None
6	%R00400	<-	deno	192.168.0.1(2)	40007	2	None

6.5.2 Register Addresses

NOTE Some soft starters do not support some functions.

The following functions are only available with Digistart D3 soft starters:
parameter management, dual motor control, digital inputs, jog, current measurement in amperes, power information, warnings.

Table 6-3 Register addresses

Register Address	Description	Bits	Details
40001	<i>Reserved</i>	0 to 14	<i>Reserved</i>
		15	Must be zero
40002	Command (single write)	0 to 2	To send a command to the starter, write the required value: 1 = Start 2 = Stop 3 = Reset 4 = Quick stop (coast to stop) 5 = Forced communication trip 6 = Start using Parameter Set 1 ¹ 7 = Start using Parameter Set 2 ¹
		3 to 7	<i>Reserved</i>
40003	Starter state	0 to 3	1 = Ready 2 = Starting 3 = Running 4 = Stopping (including braking) 5 = Restart delay (including temperature check) 6 = Tripped 7 = Programming mode 8 = Jog forward 9 = Jog reverse
		4	1 = Positive phase sequence (only valid if bit 6 = 1)
		5	1 = Current exceeds FLC
		6	0 = Unintialised 1 = Initialised
		7	<i>Reserved</i>

Register Address	Description	Bits	Details
40004	Trip code	0 to 7	See Trip Codes on page 21
40005 ²	Motor current	0 to 7	Average 3-phase motor current (A)
40006	Motor temperature	0 to 7	Motor 1 thermal model (%)
40007	Product information	0 to 2	Product parameter list version
		3 to 7	Product type code ³
40008	Serial Protocol Version	0 to 7	Communication protocol between module and starter
40009 ⁴ to 401XX	Parameter management (single/multiple read or multiple write)	0 to 7	Manage soft starter programmable parameters.
40600	Version	0 to 5	<i>Reserved</i>
		6 to 8	Parameter list version number
		9 to 15	Product type code ³
40601	Device details		
40602 ⁵	Changed parameter number	0 to 7	0 = No parameters have changed 1 to 255 = index number of the last parameter changed
		8 to 15	Total number of parameters available in the starter
40603 ⁵	Changed parameter value	0 to 13	Value of the last parameter that was changed, as indicated in register 40602
		14 to 15	<i>Reserved</i>
40604	Starter state	0 to 4	0 = <i>Reserved</i> 1 = Ready 2 = Starting 3 = Running 4 = Stopping 5 = Not ready (restart delay, restart temperature check, run simulation, input A (DI4, +24V) not shorted) 6 = Tripped 7 = Programming mode 8 = Jog forward 9 = Jog reverse
		5	1 = Warning
		6	0 = Uninitialised 1 = Initialised
		7	0 = Local control 1 = Remote control
		8	0 = Parameter(s) have changed since last parameter read 1 = No parameters have changed ⁵
		9	0 = Negative phase sequence 1 = Positive phase sequence
		10 to 15	See Trip Codes on page 21 ⁶
40605 ²	Current	0 to 13	Average rms current across all three phases
		14 to 15	<i>Reserved</i>
40606	Current	0 to 9	Current (% motor FLC)
		10 to 15	<i>Reserved</i>
40607	Motor temperature	0 to 7	Motor 1 thermal model (%)
		8 to 15	Motor 2 thermal model (%)
40608 ⁷	Power	0 to 11	Power
		12 to 13	Power scale
		14 to 15	<i>Reserved</i>
40609	% Power factor	0 to 7	100% = power factor of 1
		8 to 15	<i>Reserved</i>

Register Address	Description	Bits	Details
40610	<i>Reserved</i>		
40611 ²	Current	0 to 13 14 to 15	Phase 1 current (rms) <i>Reserved</i>
40612 ²	Current	0 to 13 14 to 15	Phase 2 current (rms) <i>Reserved</i>
40613 ²	Current	0 to 13 14 to 15	Phase 3 current (rms) <i>Reserved</i>
40614	<i>Reserved</i>		
40615	<i>Reserved</i>		
40616	<i>Reserved</i>		
40617	Parameter list version number	0 to 7 8 to 15	Parameter list minor revision Parameter list major version
40618	Digital Input state	0 to 15	For all inputs, 0 = open, 1 = closed (shorted) 0 = Start 1 = Stop 2 = Reset 3 = Input A 4 = Input B 5 = Input C, if fitted 6 = Input D, if fitted 7 to 15 = <i>Reserved</i>
40619 to 40631	<i>Reserved</i>		

¹ Ensure that the programmable input is not set to Motor Set Select before using this function.

² For models D3-1x-0053-B and smaller this value will be 10 times greater than the value displayed on the keypad.

³ Product type code:

4 = Digistart D2

8 = Digistart D3

⁴ See the relevant soft starter literature for a complete parameter list. The first product parameter is always allocated to register 40009. The last product parameter is allocated to register 40XXX, where XXX = 008 plus total number of available parameters in the product.

⁵ Reading register 40603 (Changed parameter value) will reset registers 40602 (Changed parameter number) and 40604 (Parameters have changed). Always read registers 40602 and 40604 before reading register 40603.

⁶ Bits 10 to 15 of register 40604 report the soft starter's trip or warning code. If the value of bits 0 to 4 is 6, the soft starter has tripped. If bit 5 = 1, a warning has activated and the starter is continuing to operate.

⁷ Powerscale functions as follows:

0 = multiply Power by 10 to get W

1 = multiply Power by 100 to get W

2 = Power is represented in kW

3 = multiply Power by 10 to get kW

6.5.3 Examples

Figure 6-6 Send start command (register 40002)

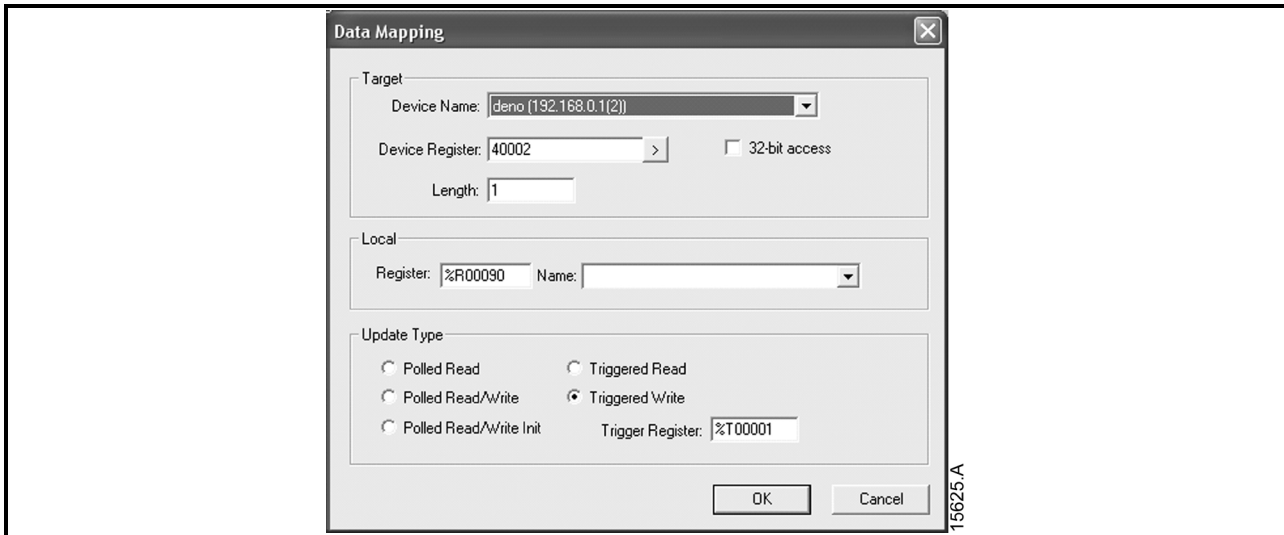

Figure 6-7 Get status (starting at register 40003)

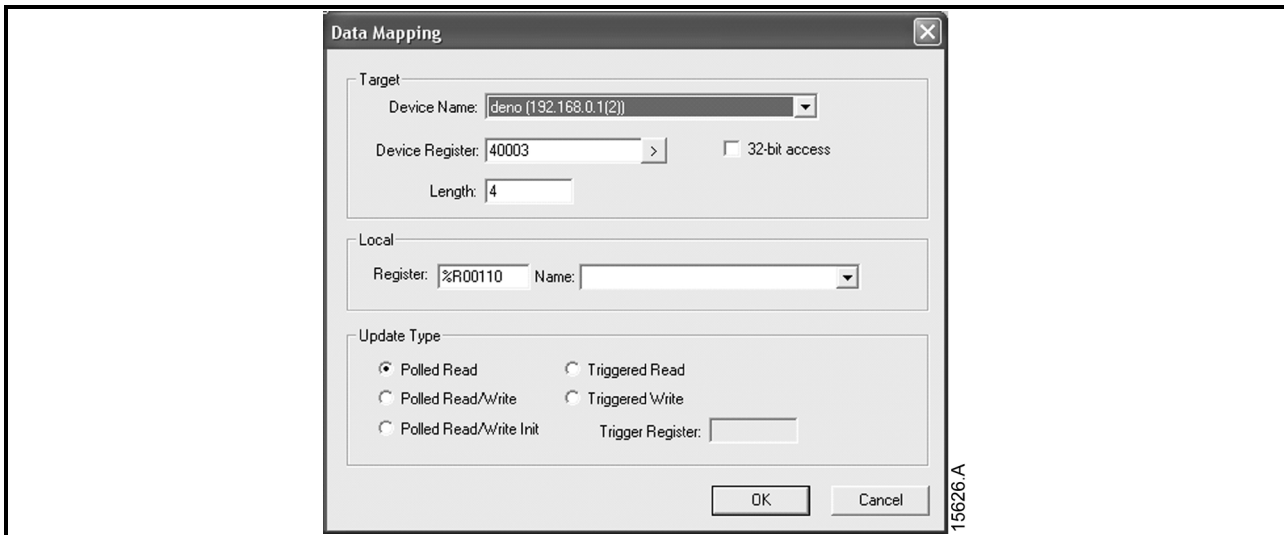
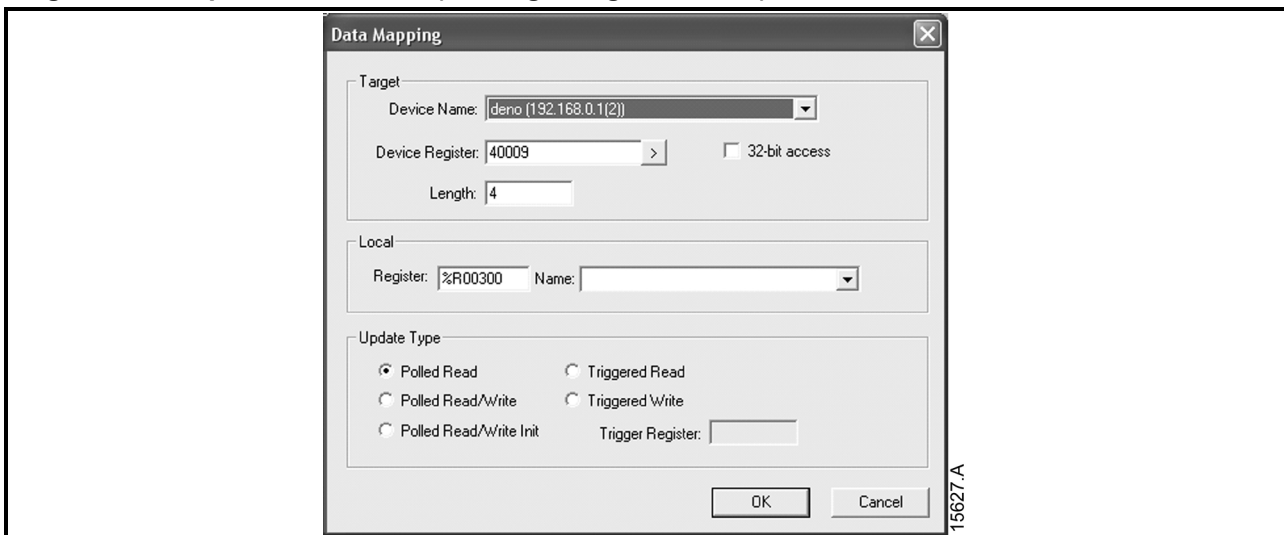

Figure 6-8 Get parameter values (starting at register 40009)



6.6 Trip Codes

Table 6-4 Trip messages

Trip Code	Description	Digistart D2	Digistart D3
1	Excess start time	●	●
2	Motor overload	●	●
3	Motor thermistor	●	●
4	Current imbalance	●	●
5	Frequency	●	●
6	Phase sequence	●	●
7	Instantaneous overcurrent		●
8	Power loss	●	●
10	Heatsink overtemperature		●
11	Motor Connection Tx		●
12	Input A trip		●
13	FLC too high		●
14	Unsupported option (function not available in inside delta)		●
15	Starter communication (between module and soft starter)	●	●
16	Network communication (between module and network)	●	●
17	Internal fault x (where x is the fault code detailed in the table below)		●
20 ¹	Ground fault		●
23	Parameter out of range		●
24	Input B trip		●
26	L1 phase loss		●
27	L2 phase loss		●
28	L3 phase loss		●
29	L1-T1 shorted		●
30	L2-T2 shorted		●
31	L3-T3 shorted		●
32	Motor 2 overload		●
33 ²	Time-overcurrent (Bypass overload)	●	●
35	Battery/clock		●
36	Thermistor circuit		●
37	RTD/PT100 A		●
38 ¹	RTD/PT100 B		●
39 ¹	RTD/PT100 C		●
40 ¹	RTD/PT100 D		●
41 ¹	RTD/PT100 E		●
42 ¹	RTD/PT100 F		●
43 ¹	RTD/PT100 G		●
45	RTD/PT100 X Cirtct		●
46	Analog input trip		●
47	Overpower		●
48	Underpower		●
255	No trip	●	●

¹ Available with Digistart D3 only if the appropriate option card is fitted.

² For Digistart D3, time-overcurrent protection is only available on internally bypassed models.

6.6.2 Internal Fault x

The table below details the internal fault code associated with trip code 17.

Table 6-5 Internal fault X

Internal fault	Message displayed on the keypad
70 to 72	Current Read Err Lx
73	ATTENTION! Remove Mains Volts
74 to 76	Motor Connection Tx
77 to 79	Firing Fail Px
80 to 82	VZC Fail Px
83	Low Control Volts
84 to 98	Internal fault X Contact your local supplier with the fault code (X).

NOTE Only available on Digistart D3 soft starters. For parameter details, see the soft starter User Manual.

7. Network Design

The Modbus TCP Module supports star, line and ring topologies.

7.1 Star Topology

In a star network, all controllers and devices connect to a central network switch.

Figure 7-1 Star network topology

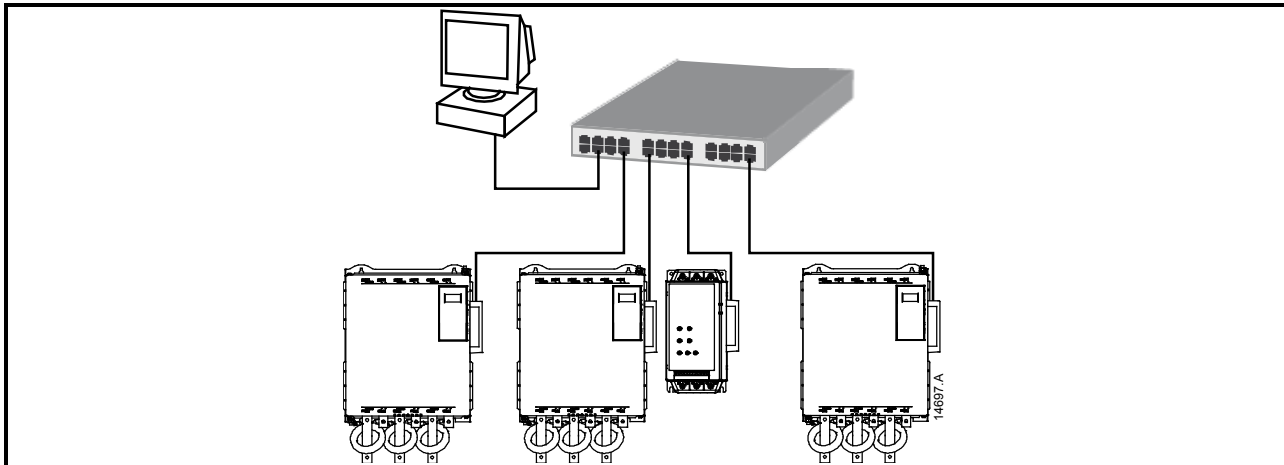

7.2 Line Topology

In a line network, the controller connects directly to one port of the first Modbus TCP Module. The second Ethernet port of the Modbus TCP Module connects to another module, which in turn connects to another module until all devices are connected.

Figure 7-2 Line network topology

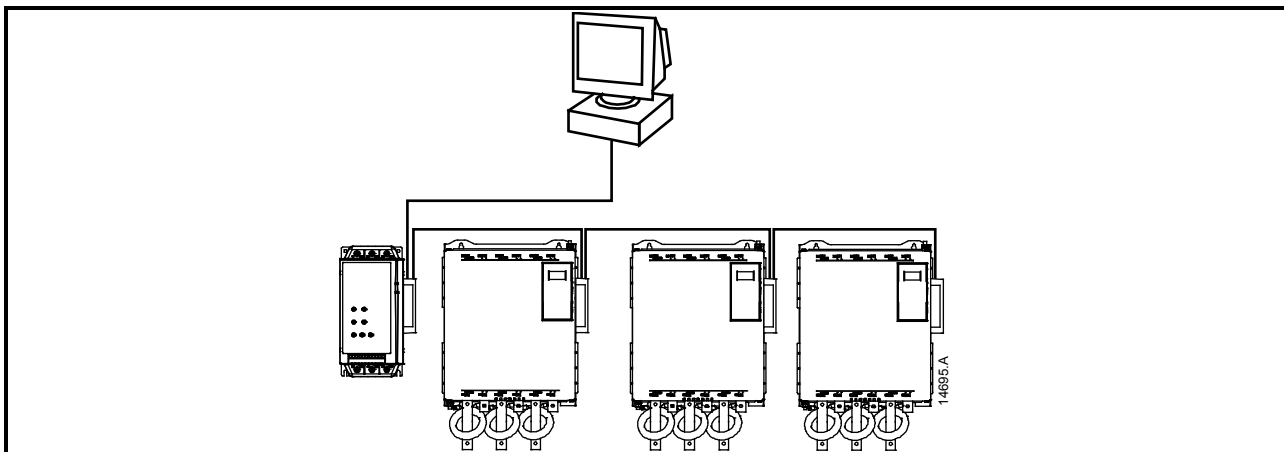

NOTE The Modbus TCP Module has an integrated switch to allow data to pass through in line topology. The Modbus TCP Module must be receiving control power from the soft starter for the switch to operate.

NOTE If the connection between two devices is interrupted, the controller cannot communicate with devices after the interruption point.

NOTE Each connection adds a delay to communication with the next module. The maximum number of devices in a line network is 32. Exceeding this number may reduce the reliability of the network.

7.3 Ring Topology

In a ring topology network, the controller connects to the first Modbus TCP Module, via a network switch. The second Ethernet port of the Modbus TCP Module connects to another module, which in turn connects to another module until all devices are connected. The final module connects back to the switch.

Figure 7-3 Ring network topology

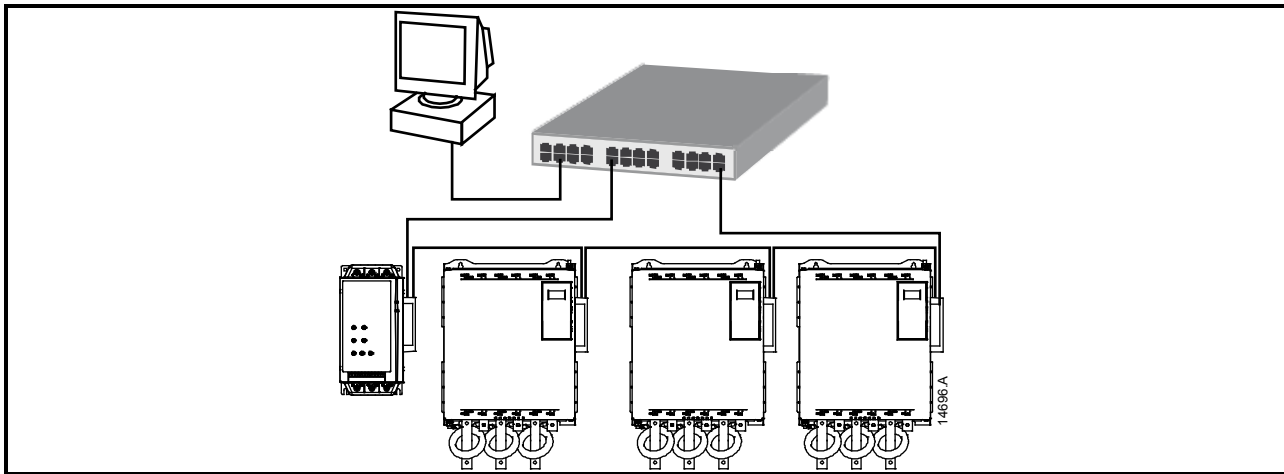

NOTE The network switch must support loss of line detection.

7.4 Combined Topologies

A single network can include both star and line components.

Figure 7-4 Combined star/line network topology

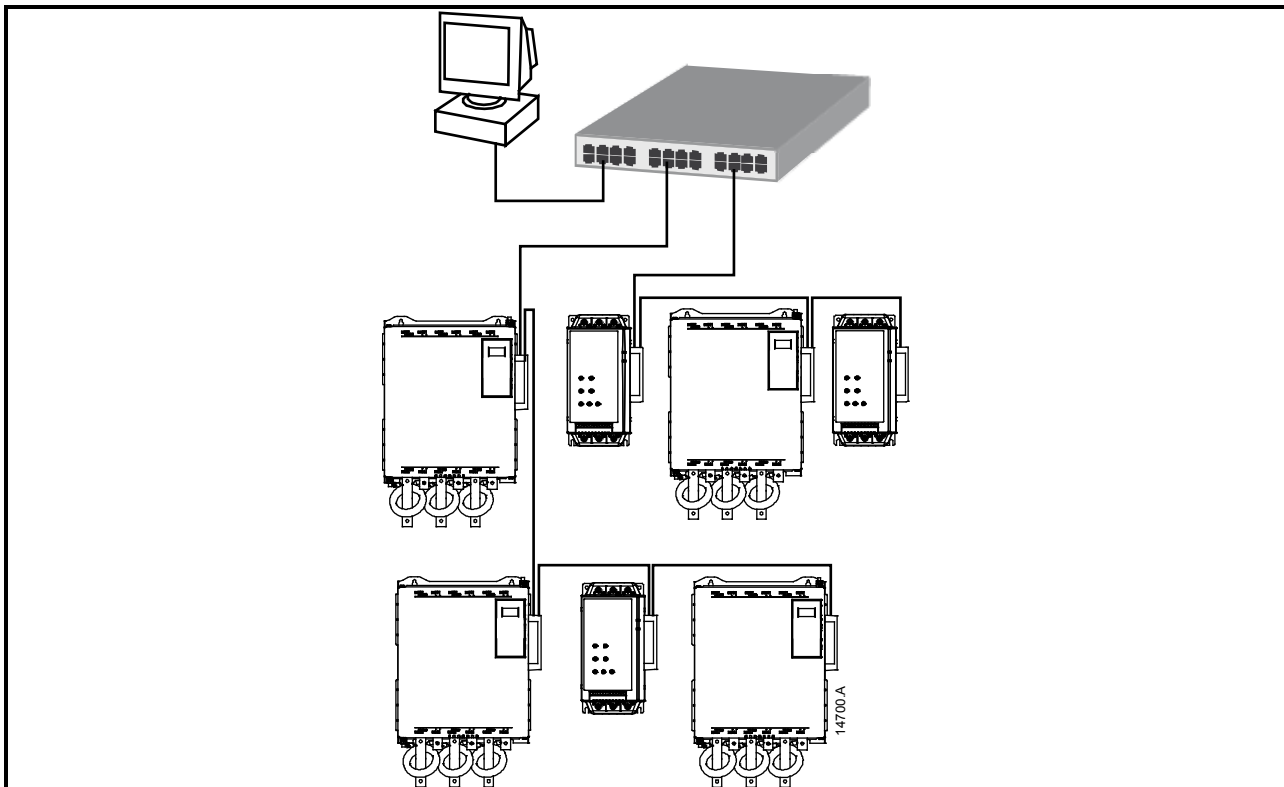

8. Specifications

Enclosure

Dimensions 40 mm (W) x 166 mm (H) x 90 mm (D)
Weight 250 g
Protection IP20

Mounting

Spring-action plastic mounting clips (x 2)

Connections

Soft starter 6-way pin assembly
Contacts Gold flash
Network RJ45

Settings

IP address Automatically assigned, configurable
Device name Automatically assigned, configurable

Network

Link speed 10 Mbps, 100 Mbps (auto-detect)
Full duplex
Auto crossover

Power

Consumption (steady state, maximum) 35 mA at 24 Vdc
Reverse polarity protected
Galvanically isolated

Certification

CE EN 60947-4-2



7 1 0 - 1 5 2 2 1 - 0 0 D