

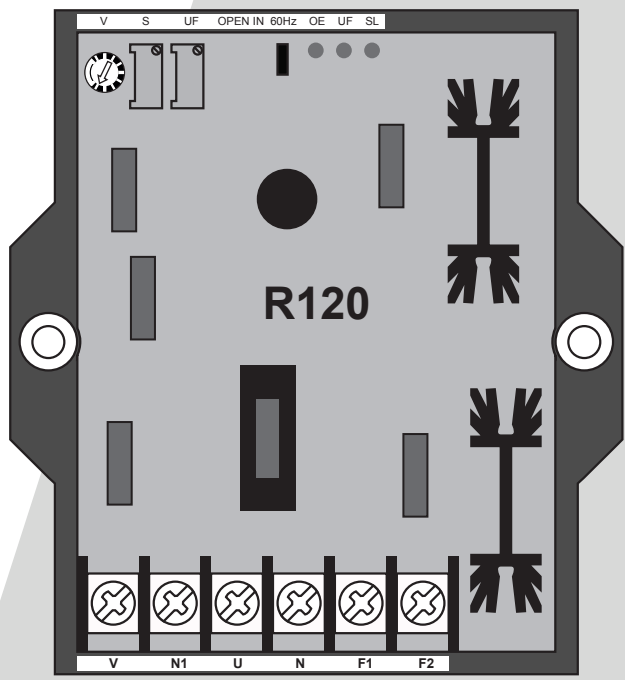

Power



# R120

AVR

Installation and maintenance

# R120 AVR

**This manual concerns the alternator AVR which you have just purchased.  
We wish to draw your attention to the contents of this maintenance manual.**

## SAFETY MEASURES

Before using your machine for the first time, it is important to read the whole of this installation and maintenance manual.

All necessary operations and interventions on this machine must be performed by a qualified technician.

Our technical support service will be pleased to provide any additional information you may require.

The various operations described in this manual are accompanied by recommendations or symbols to alert the user to potential risks of accidents. It is vital that you understand and take notice of the following warning symbols.

### WARNING

**Warning symbol for an operation capable of damaging or destroying the machine or surrounding equipment.**



**Warning symbol for general danger to personnel.**



**Warning symbol for electrical danger to personnel.**



**All servicing or repair operations performed on the AVR should be undertaken by personnel trained in the commissioning, servicing and maintenance of electrical and mechanical components.**



**When the generator is driven at a frequency below 28 Hz for more than 30 seconds with an analogue AVR, its AC power supply must be disconnected.**

## WARNING

**This AVR can be incorporated in a EC-marked machine.  
This manual is to be given to the end user.**

© 2024 Moteurs Leroy-Somer SAS  
Share Capital: 32,239,235 €, RCS Angoulême  
338 567 258.

We reserve the right to modify the characteristics of this product at any time in order to incorporate the latest technological developments. The information contained in this document may therefore be changed without notice.

This document may not be reproduced in any form without prior authorization.

All brands and models have been registered and patents applied for.

# R120 AVR

## CONTENTS

<b>1 - GENERAL DESCRIPTION</b> .....	<b>4</b>
<b>2 - OPERATION OF THE AVR</b> .....	<b>4</b>
<b>3 - TECHNICAL SPECIFICATION</b> .....	<b>5</b>
<b>4 - MAIN FUNCTION OF THE AVR</b> .....	<b>6</b>
<b>5 - AVR SETTINGS</b> .....	<b>7</b>
5.1 - V-TRIM (V) .....	7
5.2 - FRO (UF) .....	7
5.3 - STAB (S) .....	7
<b>6 - AVR CONTROLS</b> .....	<b>7</b>
<b>7 - TROUBLESHOOTING CHART</b> .....	<b>8</b>
<b>8 - MULTIMETER CHECKS</b> .....	<b>9</b>
<b>9 - STATIC TEST PROCEDURE</b> .....	<b>10</b>
<b>10 - DIMENSIONS</b> .....	<b>12</b>
<b>11 - SPARE PARTS</b> .....	<b>13</b>
11.1 - Designation .....	13
11.2 - Technical support service .....	13

### Disposal and recycling instructions

# R120 AVR

## 1 - GENERAL DESCRIPTION

The R121 automatic voltage regulator (AVR) is a compact, high-performance encapsulated unit. It incorporates the latest technology and efficient components to achieve a high degree of miniaturisation when used with 3-phase and 1-phase AC brushless generators within its input and output limits. The unit offers excellent reliability.

The AVR provides DC excitation to the exciter field of a brushless generator to keep the voltage within the approximate operating limits from NO-LOAD to FULL LOAD.

The typical recovery time in the event of sudden loading is around 0.5 sec. to recover 98% of the rated voltage. Transient performance such as voltage dip and recovery time is mainly determined by the generator and exciter design parameters. Optimum AVR performance can be obtained by keeping full-load excitation to around 60 VDC.

The generator uses a true average sensing circuit, dV/dt snubber and special filter circuits to manage NON-LINEAR loads such as battery chargers, DC motors, etc.

Voltage regulation is only guaranteed for linear loads. Severely distorting NON-LINEAR loads can cause regulation problems.

Each AVR is tested prior to dispatch as part of a quality plan, for standard voltage and frequency.

A soft-start circuit is included which provides smooth control of the build-up of generator output voltage.

A frequency roll-off circuit continuously monitors the generator underspeed protection by reducing the generator output voltage in proportion with the speed below a threshold.

## 2 - OPERATION OF THE AVR

The AVR is powered by the line-to-neutral terminal of the AC generator, with 240 VAC rms at 50 Hz or 60 Hz. The sensing voltage, which is the regulated voltage, is based on line-to-line (for 3-phase) and line-to-neutral (for 1-phase). The AVR forms an important part of the closed loop system comprising the generator field, generator armature and the AVR.

The AVR first builds up the generator voltage from its residual levels, to the rated value of 415 V for 3-phase and 240 V for 1-phase. When the generator is loaded, the sensed voltage decreases and generates an error voltage, which is required in order for the closed loop system to work.

The AVR contains a high gain amplifier, ramp and a pedestal circuit. Depending upon the value of the amplifier voltage (either high or low) the ramp intersects the amplified voltage at a point, which is either early or late in the half-cycle. At this intersection point a starting pulse is produced to trigger the power device.

When the power device is triggered early in the half-cycle, more voltage is transmitted to the field and when triggered late in the half-cycle, less voltage is transmitted to the field.

In order to reduce the generator voltage at low speed, a signal inversely proportional to the speed is generated as an extra input. At higher speeds the voltage decreases at a faster rate than in proportion with the speed.

# R120 AVR

## 3 - TECHNICAL SPECIFICATION

### 1) Sensing input

- Voltage: 277 VAC  $\pm$  10% for 1-phase, 415 VAC line-to-line  $\pm$  10% for 3-phase, 2-line sensing. The AVR senses the true average of the line-to-line waveform. Use the resistor (SMD) network for trouble-free sensing and control of sensed voltage/ regulation.

### 2) Input power

- Voltage: 277 VAC rms  $\pm$  10%  
- Frequency: 50/60 Hz

### 3) Output power

- Voltage: 95 VDC for 240 VAC Input  
- Current:  
• 4 A DC  
• 6 A for 30 sec. (when allowed by the field resistance)

4) Operating temperature: -20°C to +70°C

5) Storage temperature: -40°C to +80°C

6) Voltage setting: min  $\pm$  10% of rated voltage.

7) Stability setting: can be adjusted to obtain a correct transient response in steady state.

8) Under frequency roll-off setting: available below 46 Hz for 50 Hz and below 56 Hz for 60 Hz.

9) Voltage build-up: 2 Volts (L-N)

10) Voltage regulation:  $\pm$  1% at the AVR terminals with a THC <5%.

11) Thermal drift:  $\pm$  1% for 30°C change in temperature.

12) Response time: less than 50 ms.

13) Closed loop response: typically 0.5 sec to recover 98% of the defined voltage for a field forcing ratio of 1:2.

14) Sensing loss protection: the voltage should disappear when the sensing circuit is open.

15) Overexcitation protection set point: 85 VDC.

16) Protection fuse: 4 A, 240 VAC.

17) Potentiometer sealing: except for the V-trim potentiometer, all potentiometers are sealed.

18) Frequency roll-off indicator: LED provided (UF).

19) Sensing loss indicator: LED provided (SL).

20) Overexcitation indicator: LED provided (OE).

21) Protection on the devices: suitable R-C snubber to be provided for the device used to protect against voltage surges.

22) Potting/Encapsulation details: the components on the AVR should be completely encapsulated with suitable PU resin compound to absorb transients/ vibrations during operation.

23) Alternator excitation details: (typical)

- Full load:

- Excitation voltage: 40 to 50 V
- Excitation current: 2.5 to 4.0 A

24) Terminal marking: see diagram

25) Dimensions:

- Overall: 104 x 94 x 40 (mm)
- Mounting: 83 (mm)
- Mounting hole dia: 5.5 (mm)

26) Weight: 185 g

# R120 AVR

## 4 - MAIN FUNCTION OF THE AVR

The AVR is powered by the line-to-neutral terminals of the AC generator with 240 VAC at 50/60Hz. The regulated sensing voltage is based on the AVR input power.

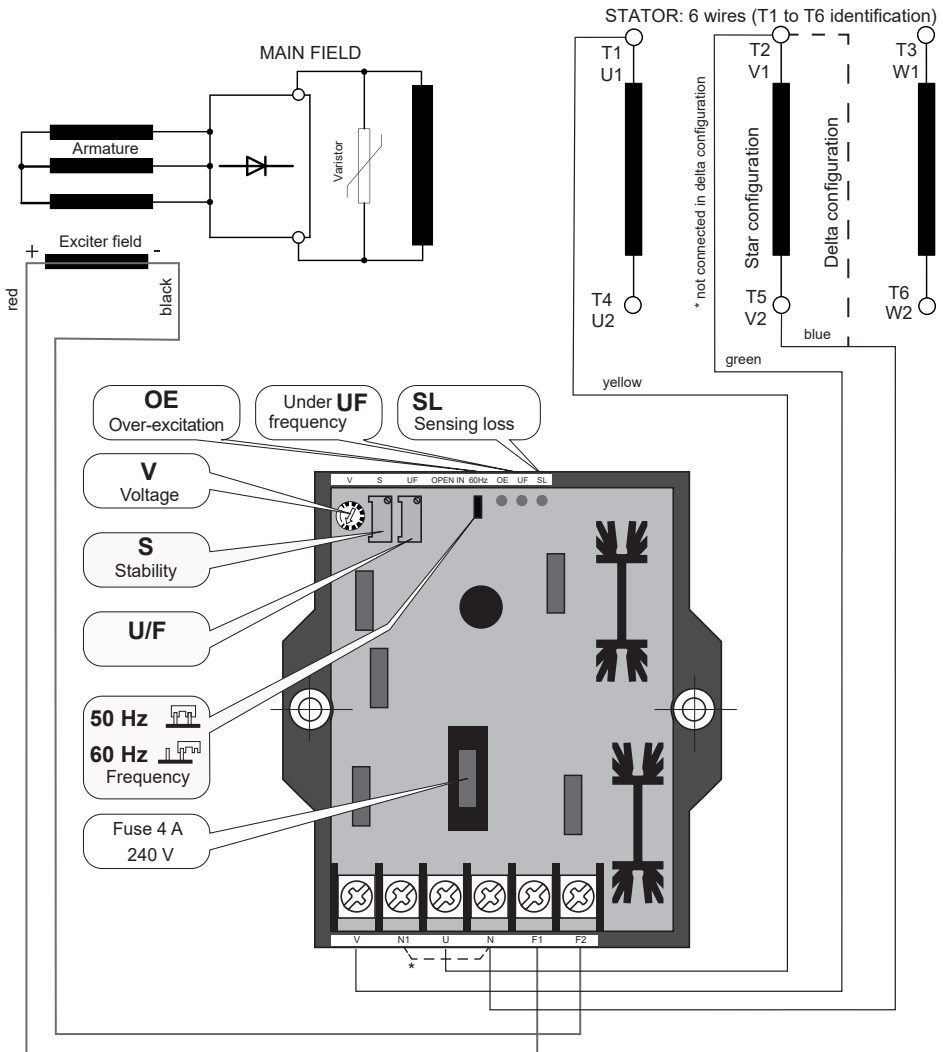

\* Note: for delta configuration (1PH – 3PH), use terminals N and U, short N and N1.

# R120 AVR

The AVR builds up the generator voltage from its residual voltage to rated voltage.

When the generator is loaded, the sensed voltage decreases and generates an error signal, which is required in order for the closed loop system to work.

Depending upon the value of the amplified voltage, the ramp intersects the amplified voltage at a point which is early or late in the half-cycle.

At this intersection point, a starting pulse is produced to trigger the power device.



**Only qualified personnel should replace/work on the AVR.**

**Do not increase the voltage beyond the rated voltage.**

## 5 - AVR SETTINGS

### 5.1 - V-TRIM (V)

This function is provided for setting the voltage up to  $\pm 10\%$  of rated voltage by means of a potentiometer. Turn the potentiometer clockwise to increase the voltage and vice versa, once the rated speed has been reached.

**The default setting is 415 V  $\pm$  2% for 3-phase, 240 V  $\pm$  2% for 1-phase.**

### 5.2 - UNDER FREQUENCY KNEE POINT SETTING (UF)

This function is provided to protect the AC generator from sustained low speed operation through a potentiometer. The AVR will reduce the voltage in proportion with the speed below the defined value.

The procedure for setting the UF potentiometer is as follows:

First run the generator at full speed (50 Hz) and turn UF by a few turns clockwise, making sure that the voltage does not increase. Now turn the UF potentiometer slowly anticlockwise. At a particular point the red LED glows and the voltage will start to decrease. Stop turning the potentiometer at this point and turn the potentiometer clockwise by two turns after rated voltage is restored.

**The factory default setting is 46 Hz.**

### 5.3 - STAB (S)

This function is provided to stop voltage hunting by means of a potentiometer. Turn clockwise to increase stability (to stop oscillation). Turning too far clockwise will result in a sluggish response and possibly also oscillations.

**The factory default setting is slightly higher than critical damping (around halfway).**

## 6 - AVR CONTROLS

No.	Control	Function	Direction
1	VOLTS	Sets the generator output voltage	Turn clockwise to increase output voltage
2	STAB	Stops voltage hunting	Turn clockwise to increase stability
3	UFRO	Sets the Under frequency knee point	Turn clockwise to to reduce the knee point

# R120 AVR

## 7 - TROUBLESHOOTING CHART

Symptom	Cause	Action
<b>No voltage build-up</b>	Fuse blown	Check and replace
	Low residual voltage across U and N terminals	If the generator's residual voltage at rated speed is less than 2.5 VAC (L-N), disconnect the AVR and connect a 24 VDC battery, keeping F1 as positive and F2 as negative. Connecting a freewheel diode (BY 127) across the field with the diode cathode to F1 and the anode to F2 during field flashing will help restore the residual voltage. <b>WARNING:</b> Remove the diode (BY-127) after field flashing. The 24 V battery positive terminal must only be connected to F1 and the negative to F2. Swapping the connection will cause diode BY127 to explode instantly.
	Incorrect wiring	Check wiring
	Rotating diodes and/or fuse failed	Check and replace
	Voltmeter on the front defective	Check and correct
	AVR defective (repeated fuse blowing)	Replace after performing a static test
<b>High voltage build-up</b>	Earthed exciter field	Check and correct
	Loose or missing connection to AVR U terminal	Check and correct
<b>Low voltage build-up</b>	AVR defective	Perform a static test and replace if necessary
	Low prime mover speed	Check and correct
	Sensing loss in circuit	Check and correct
<b>Voltage oscillation</b>	AVR defective	Replace the AVR
	Incorrect stability potentiometer sealing	Turn clockwise until hunting stops
	Prime mover speed hunting	Check and adjust the controller
	Load hunting, fluctuates rapidly	Check and correct
	High percentage of non-linear loads	Check and reduce the non-linear load
<b>Incorrect regulation</b>	High reactance in generator (during non-linear loading)	Consult the generator manufacturer
	The exciter field's requirement is higher than 95 VDC	Wrong selection or very low P.F. load. Check and correct.
	Prime mover speed drops too much when on load (kW load)	Adjust the controller and reduce the active load



# R120 AVR

## 8 - MULTIMETER CHECKS

**Equipment: Digital multimeter, Type: MECO or equivalent.**

Select Diode mode on the digital multimeter. The resistance between F1 and F2 (with the multimeter jack common applied to F1 of the AVR) should be between 0.4 and 0.6 k $\Omega$ , and vice versa (with the multimeter jack common applied to F2 of the AVR) should give **INFINITY**.

**ZERO** indicates a power device failure in both cases, No further tests (static or dynamic) are allowed, as they would lead to the fuse blowing.

The resistance between F2 and U (both sides) should be 180 k $\Omega$ .

The resistance between F2 and V with the multimeter jack common applied to the AVR V terminal should be approximately 2.2 M $\Omega$  in the 10 M $\Omega$  range and vice versa (with the multimeter jack common applied to the AVR F2 terminal) should be 15 M $\Omega$ .

**ZERO** indicates a power device failure in both cases, No further tests (static test or dynamic tests) are allowed, as they would to the fuse blowing.

The resistance between U and V should be between 300 k $\Omega$  and 400 k $\Omega$ . Open circuit indicates AVR failure. During a static test, the lamp will not turn OFF or, when connected to the generator, it will produce a ceiling voltage (for 3-phase ONLY).

The resistance between U and N1 should be between 200 k $\Omega$  and 260 k $\Omega$ .

Open circuit indicates AVR failure. During a static test, the lamp will not turn OFF or, when connected to the generator, it will produce a ceiling voltage (for 1-phase ONLY).

The resistance between N and F1 should be very low or ZERO ohms. If the circuit is open, the lamp will not glow when the static test is performed.

# R120 AVR

## 9 - STATIC TEST PROCEDURE

### For 3-phase circuit

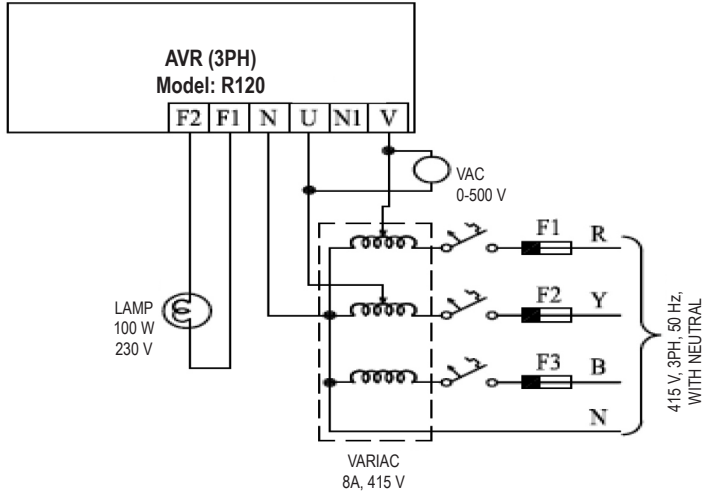

STATIC TEST CONNECTION DIAGRAM OF 3PH AVR

This test should only be attempted after making sure that the AVR has passed all multimeter checks. Connect the AVR to the three-phase variable voltage source as shown in diagram 3 in this manual.

1. Keep 'V-TRIM' in the minimum position.
2. Keep UF in the fully maximum position.
3. Increase the applied voltage. The lamp should glow increasingly brightly. At a voltage of around 360-380 V the lamp should go out slowly. Increase the voltage again up to 415 V. The lamp should stay OFF. Decrease the voltage to below 360 V. The lamp should glow brightly again.
4. Turn the UF potentiometer anticlockwise; the lamp should go out slowly. Now turn the UF potentiometer clockwise. The lamp should glow brightly again.

5. It is difficult to prescribe a static test for checking the stability, as this is more easily detected during closed loop tests. However, a healthy AVR will behave as described below.

First keep the 'STAB' potentiometer in the fully anticlockwise position. Perform the static test as described in steps 1, 2 and 3. The lamp will go out fairly quickly at 360-380 V and come on again quickly when the voltage is reduced to below 360 V. Now keep the 'STAB' potentiometer fully clockwise, and perform the static test as in 1, 2, and 3. The lamp should go out much more slowly and come on again much more slowly. At the end of this test reset the potentiometer in the middle position.

**If the AVR behaves as described above then it is in good working order.**

# R120 AVR

## For 1-phase circuit

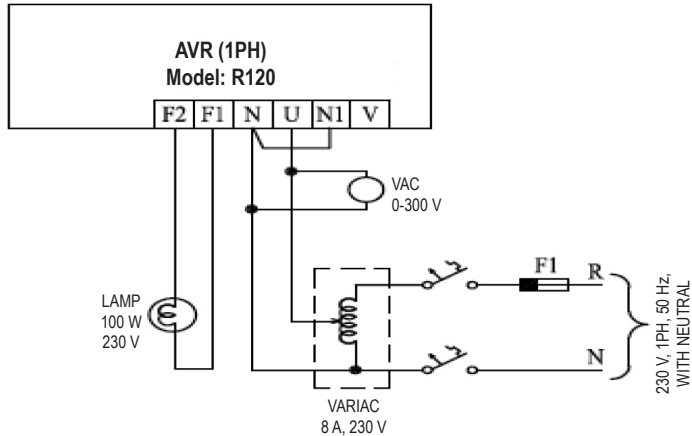

STATIC TEST CONNECTION DIAGRAM OF 1PH AVR

This test should only be attempted after making sure that the AVR has passed all multimeter checks. Connect the AVR to the single-phase variable voltage source as shown in diagram 1 in this manual.

1. Keep 'V-TRIM' in the minimum position.
2. Keep UF in the fully maximum position.
3. Increase the applied voltage. The lamp should glow increasingly brightly. At a voltage of around 200-220 V the lamp should go out slowly. Increase the voltage again up to 240 V. The lamp should stay OFF. Decrease the voltage to below 200 volts. The lamp should glow brightly again.
4. Turn the UF potentiometer anticlockwise; the lamp should go out slowly. Now turn the UF potentiometer clockwise. The lamp should glow brightly again.

5. It is difficult to prescribe a static test for checking the stability, as this is more easily detected during closed loop tests. However, a healthy AVR will behave as described below.

First keep the 'STAB' potentiometer in the fully anticlockwise position. Perform the static test as described in steps 1, 2 and 3. The lamp will go out fairly quickly at 200-220 V and come on again quickly when the voltage is reduced to below 240 V. Now keep the 'STAB' potentiometer fully clockwise, and perform the static test as in 1, 2, and 3. The lamp should go out much more slowly and come on again much more slowly. At the end of this test reset the potentiometer in the middle position.

**If the AVR behaves as described above then it is in good working order.**

# R120 AVR

## 10 - DIMENSIONS

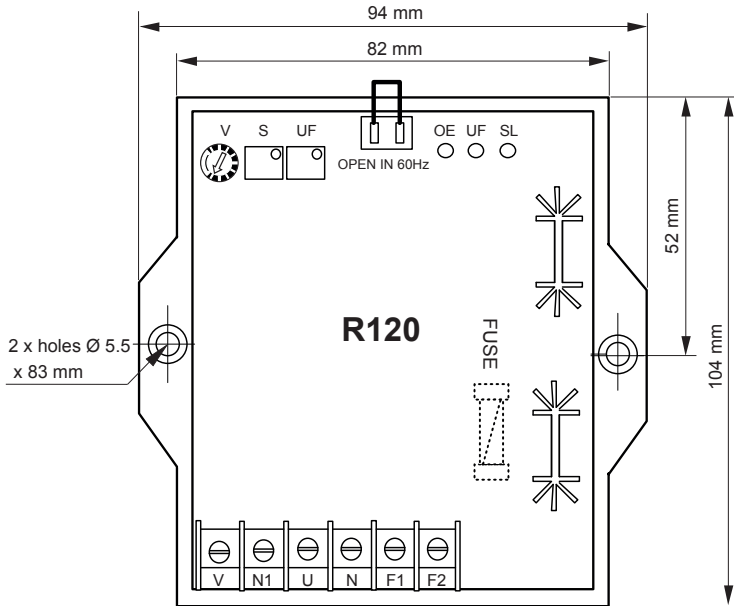

# R120 AVR

## 11 - SPARE PARTS

### 11.1 - Designation

Description	Type	Code
AVR	R120	<b>4969966</b>

### 11.2 - Technical support service

Our technical support service will be pleased to provide any additional information you may require.

For all spare parts orders or technical support requests, send your request to [service.epg@leroy-somer.com](mailto:service.epg@leroy-somer.com) or your nearest contact, whom you will find at [www.lrsm.co/support](http://www.lrsm.co/support) indicating the type and the code number of the AVR.

To ensure that our products operate correctly and safely, we recommend the use of original manufacturer spare parts.

In the event of failure to comply with this advice, the manufacturer cannot be held responsible for any damage.

# R120

## AVR

### Disposal and recycling instructions

We are committed to limiting the environmental impact of our activity. We continuously monitor our production processes, material sourcing and product design to improve recyclability and minimise our environmental footprint.

These instructions are for information purposes only. It is the user's responsibility to comply with local legislation regarding product disposal and recycling.

### Waste & hazardous materials

The following components and materials require special treatment and must be separated from the alternator before the recycling process:

- electronic materials found in the terminal box, including the automatic voltage regulator (198), current transformers (176), interference suppression module and other semi-conductors.
  - diode bridge (343) and surge suppressor (347), found on the alternator rotor.
  - major plastic components, such as the terminal box structure on some products.
- These components are usually marked with information concerning the type of plastic.

All materials listed above need special treatment to separate waste from reclaimable materials and should be entrusted to specialist recycling companies.

# Service & Support

Our worldwide service network of over 80 facilities is at your service. Our local presence is your guarantee for fast and efficient repair, support and maintenance services.

Trust your alternator maintenance and support to electric power generation experts. Our field personnel are 100% qualified and fully trained to operate in all environments and on all machine types.

We have a deep understanding of alternators operations, providing the best value service to optimize your cost of ownership.

How can we help:

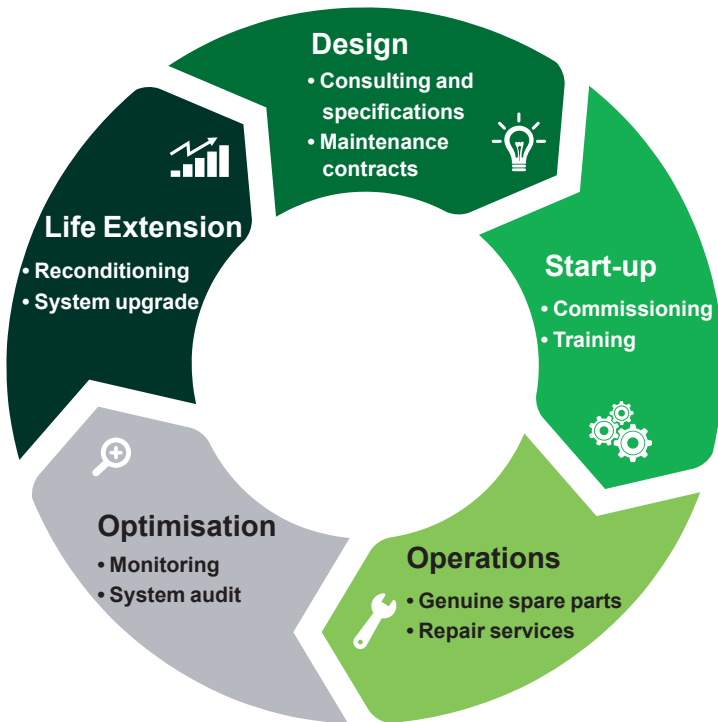

Contact us:

**Americas:** +1 (507) 625 4011

**EMEA:** +33 238 609 908

**Asia Pacific:** +65 6250 8488

**China:** +86 591 8837 3010

**India:** +91 806 726 4867



[service.epg@leroy-somer.com](mailto:service.epg@leroy-somer.com)



Scan the code or go to:  
[www.lrsom.co/support](http://www.lrsom.co/support)



[www.nidecpower.com](http://www.nidecpower.com)

Connect with us at:

