



# Port Logistics

Reliable, safe and environmentally sound automation solutions that optimize movement of containers and goods while increasing energy and fuel savings

**CONTROL TECHNIQUES™**  
**LERROY-SOMER™**

***Nidec***  
All for dreams

# Nidec's innovative automation solutions designed to meet the demands of port operators

The port is at the center of international supply chain logistics because it connects sea, rail and truck transportation from origin to destination. Port operators apply competing demands to logistics organizations, requiring increased throughput while minimizing the environmental impact and rising energy costs.

Technology and automation now dominate this industry, and with so much of a port's effectiveness defined by speed, Nidec integrated, customized and high performance solutions are innovative and reliable, and make the many processes involved in modern port logistics even more efficient, safe and profitable.

## Sustainable and customized material handling systems

Nidec's business is involved globally in port logistics to drive growth and sustainability within the industry.

The number of cargo containers globally will grow within the next decade, and new mega-sized vessels are creating fresh issues for the terminal operators to face. Nidec's highly reliable, high performance and efficient products allow us to develop solutions that can achieve faster turnaround and delivery of cargo, while increasing productivity and energy saving.

Our automation systems are tailored to exact requirements, building and developing new efficient terminals globally or refurbishing existing port equipment to achieve the best possible safety practice. Nidec believes that the key to this success and progression lies within automation, where our innovative and proven drive and motor technology controls will be the leading source of content in breakthrough technology within terminal automation.



## Nidec's global solutions and services

Nidec's variable speed modular drives, high-efficiency motors and dedicated Crane Management System (CMS) provide the basis of our fault tolerant port equipment automation solutions that increase energy and fuel savings. Installed in many port applications around the world, our automation systems provide compact and flexible solutions with the power and control required to move goods efficiently and safely.

Backed by many years of experience, our expertise allows us to maximize the automation, speed and reliability of your cranes and material handling equipment. Through our dedicated organization we provide:

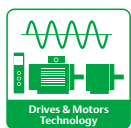

Cutting edge drives and motors technology – enhancing reliability, high performance and energy efficient solutions for port logistic operations.

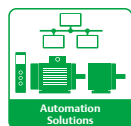

Scalable Automation Solutions – from simple drive and motor conveyor or hopper control up to a complete crane or port handling equipment automation solution, backed by our port logistics automation expertise and full support at local level.

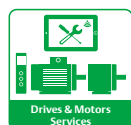

Customized local and specialist technical services – ensuring all elements of your automation system requirements are supported, such as consultation, installation, commissioning, dedicated training, maintenance and repairs for maximum performance throughout the life cycle of your port equipment.



# Drives and motors solutions for port logistics that enhance reliability, performance and energy efficiency

## Crane Management System (CMS)

Based on Industrial Personal Computers, CMS monitors the physical and operating conditions of port equipment on a real-time basis. It can be used to operate the crane, schedule maintenance, analyze faults and provide crane production data.

## Fault tolerant modular AC drives systems

Compact, reliable and powerful drive system to control crane and handling equipment movements, with built-in redundancy for continuous operations.



## Differential GPS control system (DGPS)

Highly accurate and safe automatic steering for RTG cranes and yard tracking systems linked with terminal operating system.



## Customized Integrated Automation Solutions

Nidec has developed several special port logistics control system solutions, with software based on safety PLC technology and fast communication systems via Ethernet and common fieldbuses that extend to distributed intelligence. Equipment components can be configured, programmed and commissioned faster and easier, with more cost effectivity.

## DC drive systems to minimize retrofit cost

Generally used for equipment refurbishment when saving existing DC motors. Reduces modernization costs while offering industry leading performance, communication and programming capability.





## Remote Crane Management System (RCMS)

Single or multiple crane control systems communicate with RCMS, over fiber optic cables or via wireless communication systems, to reduce equipment maintenance and downtime. RCMS can be used at maintenance level for service monitoring, operations level for equipment availability and management level for performance data.

## Comprehensive range of induction motors

Nidec's proven standard technology provides comprehensive hoisting motor range:

- High speed range to increase crane productivity
- Low inertia for smoother start/run/stop operations extend crane lifetime
- Low maintenance solution



## Regenerative system

Active front end capability in AC and DC drive systems for maximum energy saving and putting the energy back into the port grid system.

## Built-in brakes for safety

- Brakes for static hold and dynamic stop
- Safety with the FCPL built-in brakes

## Energy and fuel saving system (RISGA)

Compact, electronic and low cost fuel saving system for RTG and MHC diesel electric cranes to save operation costs and reduce emissions.

## Service and Maintenance

Available locally to enable maximum performance for the lifecycle of your port equipment.

## Dyneo® permanent magnet solutions

- Highly energy efficient compact solutions with excellent power density across the whole power range
- Ideal integration in wheel for traction

## Complete range of gear motors for trolley and gantry applications

Fully compatible for any motor technologies



# Global facilities, resources and port logistics install base



Ports where Nidec have products and solutions installed

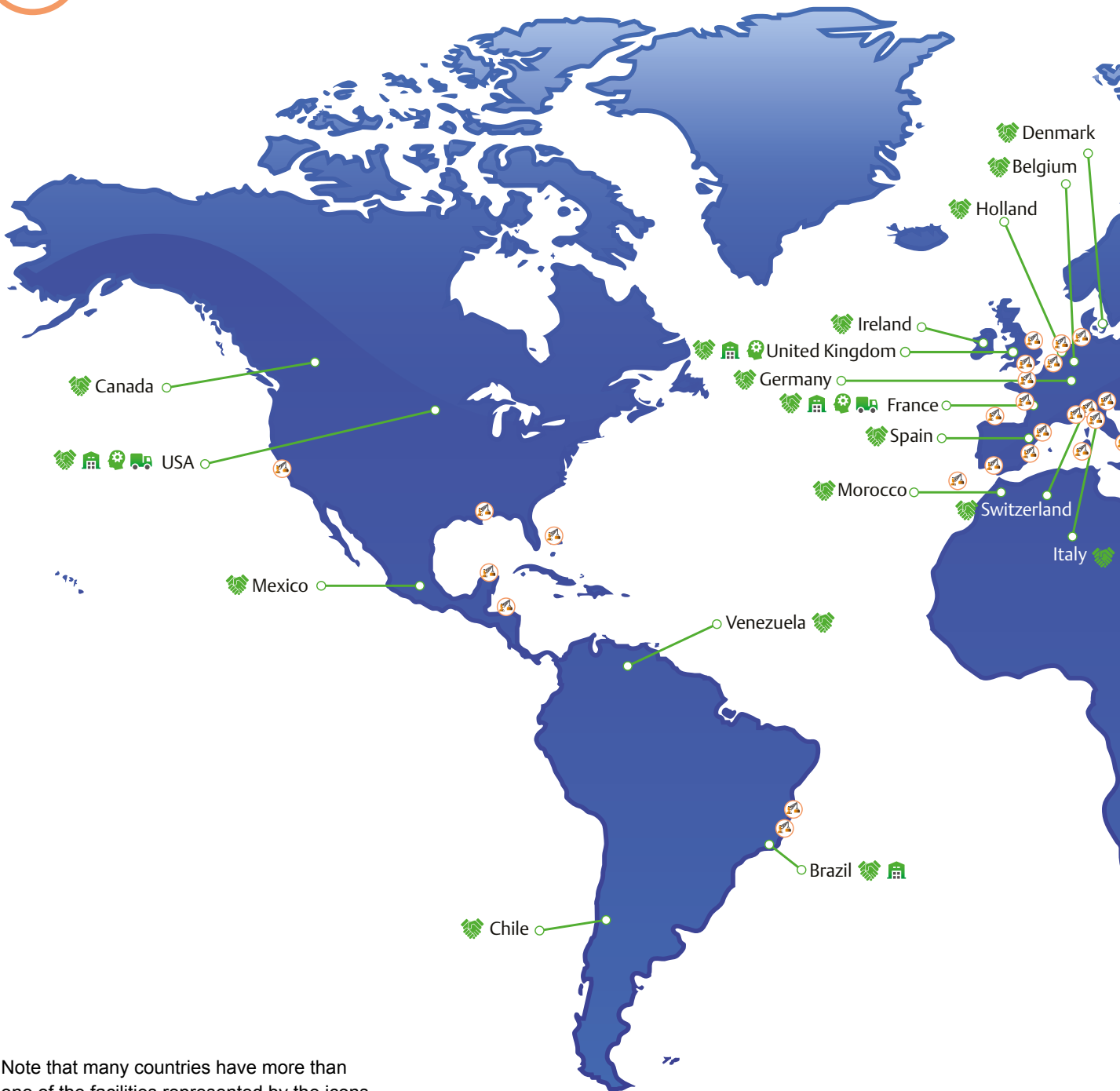

Note that many countries have more than one of the facilities represented by the icons

## An enhanced global presence that benefits all our customers

Through our integrated organization, we have an extensive global presence that provides comprehensive local support and services. This includes:



5,500 employees



### 40+ Automation Centers

Providing excellent customer support for any product, automation solutions or service requirements



### 23 Manufacturing sites

Producing a comprehensive range of high quality products, optimized for industry-specific customer requirements



### 8 Engineering and Design facilities

Develops market leading products and feature-sets using the latest design technology



### 3 Regional despatch hubs

For quick delivery of product

Our extensive sales and service networks in Europe, Asia Pacific and the Americas are backed-up by hundreds of carefully selected distributors and service partners all over the world.

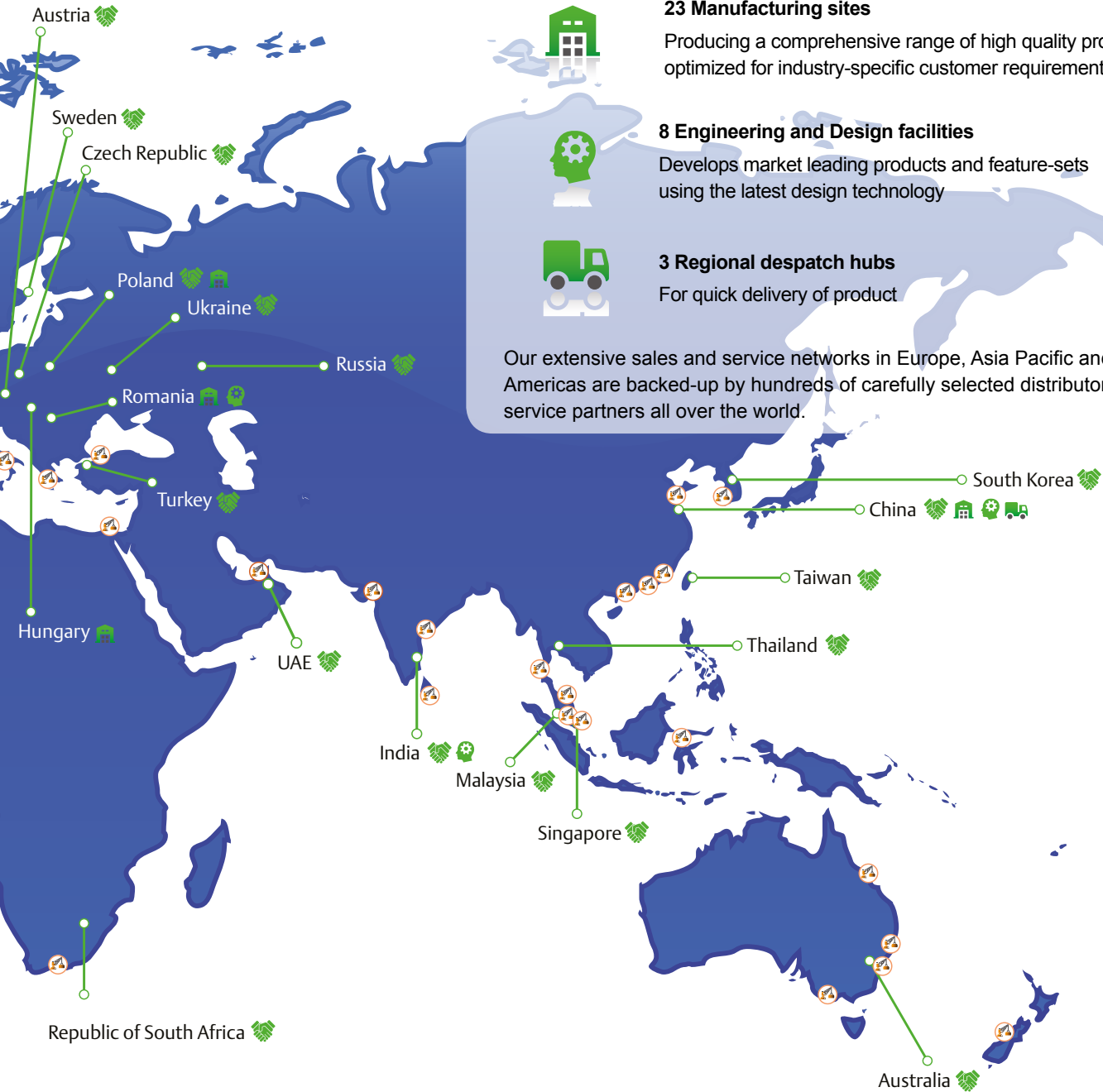

# Nidec

## Leading the way in Port Logistics Automation Solutions

As the leading port logistics automation solutions and engineering services provider, we continuously engage our customers and strategic partners to deliver the solutions they need. Through our technical expertise and knowledge we are able to both improve your business performance and minimize risk, to ensure a successful result. Projects can vary from small logistic machine automation to comprehensive electrical turnkey port automation solutions. You can be assured that we are able take on completely new equipment automation installations or modernize any existing port installed systems, whether they are Nidec or not. Nidec port logistics solutions provide the following benefits:

- Fast turn-around of containers, bulk cargo or freight by optimizing the loading /unloading and storage cycles.
- Ensure performance and availability of the port equipment through the use of reliable, modular drives systems and automation solutions.
- Assist the operator with driving the crane through intelligent and safe automation solutions.
- Help the engineering and maintenance staff to resolve and analyze faults with customized CMS or RCMS implementation

Typical quay and yard equipment applications include:

- Quay and yard container cranes such as Ship-To-Shore (STS), Mobile Harbour Cranes (MHC), Rail Mounted Gantry (RMG), Straddle Carriers (SC), Heavy Automatic Guide Vehicle (HAV), Trailer and Rubber Tired/Tyred Gantry (RTG)
- Bulk materials handling equipment such as Grab Ship Unloader (GSU), Automatic Ship Unloader (ASU), Continuous Ship Unloader (CSU), Jib crane, Floating crane, Conveyor, Feeder, Hopper and Stacker.





## Nidec: a proven partner for effective port equipment modernization

Nidec provides the expertise to help port operators make the right decisions when modernizing existing port equipment. This not only extends the lifetime of equipment and maximizes the benefits from initial investment but also increases safety and reduces operation costs. Furthermore our 'eco-friendly' innovative fuel saving solutions minimize environmental impact by reducing CO<sub>2</sub> emissions and decreasing equipment noise levels.

Nidec engineers have extensive experience of any brand of existing equipment to help port operators.

## Optimizing energy & fuel savings and relative Return on Investment

Once potential energy or fuel savings have been identified, we commit to calculate the payback period on investment or on the additional investment required for Green Technology such as power-on-demand systems. We will also provide a high yield installation and maintenance schedule to ensure optimum performance is maintained through the lifetime of your equipment.



# Project Management, System Design and Commissioning

## Project development support

Our Project Managers will be the key point of contact to assist you throughout the decision-making process, providing insight and expertise for your business case. They are split regionally to provide the knowledge of local practices and know-how you require. Once you decide to utilize Nidec, a dedicated project management team will map out a specific plan and take responsibility for engaging with you, the various teams and suppliers to drive the project forward, finishing on-time, on-specification and at the lowest cost.

## Engineering and quality assurance

Our engineering team covers all aspects of the design of port equipment automation solutions, including installation and commissioning activities. Nidec Automation Centers, with their extensive global experience, can design and implement improvements suited to your local conditions, standards and usage. Our quality assurance team is composed of highly skilled professionals who all have extensive port equipment automation solutions experience.

## Commissioning

Our commissioning team provides the face of Nidec in your port. The team is composed of experienced engineers who bring valuable knowledge of Nidec to you as a port operator. As well as technical competency and site management skills, the commissioning team work to ensure the direct link between Nidec and port staff.





## Local expert port logistics support and services

Our extensive port application expertise is available locally through our global Automation Centre network. Whether upgrading existing equipment or designing a new system, we can provide:

- In-house design and management, from small-scale retrofit to full port crane and transportation electrical systems
  - Functional engineering design
  - Detailed hardware and software engineering design
  - Motors and drives sizing
  - Software development and engineering support
  - Panel-building, installation and project commissioning
  - First class tailored services and support to ensure optimized performance throughout the system's life, future upgrades and expansion
  - Flexible systems with standardized or customer-preferred electronic components for maximum performance and easy integration with other port equipment or communication systems
- Fully-kitted drive system E-houses that can be built in-house with easy connection or on-site if required, that include:
    - Drive panels, MV switchgear, MV transformer, RISGA solutions, PLC crane automation and CMS integration
    - Operator control panels and chairs
  - Project documentation for erection and as built

We can take full responsibility for the whole project including technical support for all components, even if integrated from other vendors based on customer specification. As a result you can be assured that reliability is paramount along with easy integration with other port equipment.



# Unidrive M fault tolerant and energy efficient modular drive solutions

All equipment used for moving or transporting containers or bulk materials is critical in the smooth running of port terminals. Breakdowns, or the failure to unload ships in dock on schedule can result in huge fines, and so continuous operation is essential. Our modular systems are capable of driving loads of up to 2.8 MW, and yet each drive module is compact and light enough to be easily handled on site, simplifying installation and maintenance. They can be configured to provide redundancy so that cranes can continue to operate, even if a module fails. Energy efficient fault tolerant drive and motor solutions increase operations, but with reduced operation costs and low spares requirements onsite.

Other product features that enhance robustness include:

- Special conformal coating on PCBs to protect them from the sea environment
- Excessive product testing in harsh environments

## Regenerative crane systems to generate energy

Our modular AC and DC drive crane systems can set-up with an Active Front End (regenerative mode) where control of the brakes via the drive software and constant power hoisting via feedback from load-cells prevents overload/over-speed. During lowering operations, the system is able to automatically move into regeneration mode to feed energy back into the common bus system to provide significant savings in overall energy consumption, or power-up auxiliary equipment. Where appropriate, energy on cranes can be also be channelled into energy storage systems and utilized to reduce energy consumption.

## Power configurations

### Standard solutions for harmonic conformance

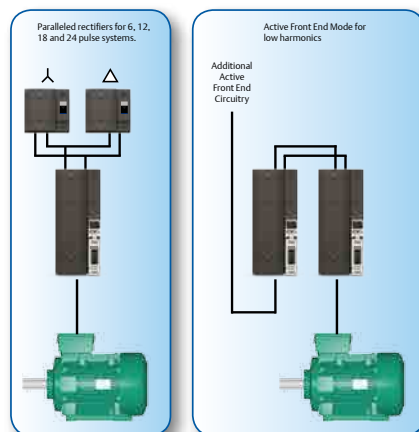

### High power parallel inverter system

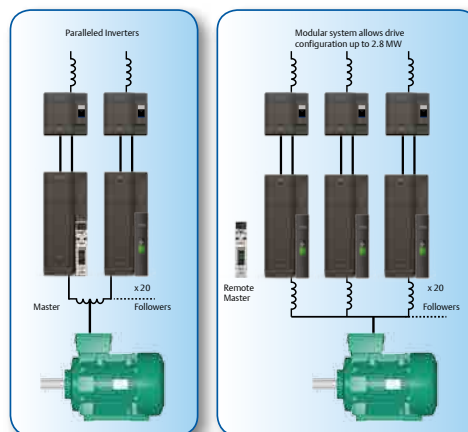



### Simple compliance with global efficiency standards

Energy consumption and costs can account for up to 60 percent of a port's operating expenses. Our variable motor and drive technologies combine to maximize energy savings and performance while easily meeting global efficiency standards. This includes IE2, IE3, IE4 for Europe and NEMA efficiency standards for the US.

### Guarantee the safety of your equipment

Our drives and motors technology provide a number of features to make your port equipment safer, including:

- A range of motors and brake gear motors for static hold and dynamic braking
- Variable speed drives with built in safety features for electric brake control and overspeed management
- Compliance with European handling federation recommendations (FEM)



# Energy and fuel saving systems

## Reliable motor and drive technologies that maximize energy savings and performance

Our advanced drives and motors technology and automation solutions meet these challenges by focusing on maximizing energy savings across a range of solutions, enhancing performance and optimizing productivity.

Electric motors account for nearly 65% of the electricity used by the port logistics industry. Our highly reliable drives and motors solutions are developed together to maximize energy savings and performance:

Dyneo® Permanent Magnet solutions and IE2/3 induction solutions, combine with variable speed drive technologies to offer industry-leading levels of energy saving.

Unidrive M dedicated industrial automation drive family has defined feature-sets to optimize performance and productivity across a wide range of applications

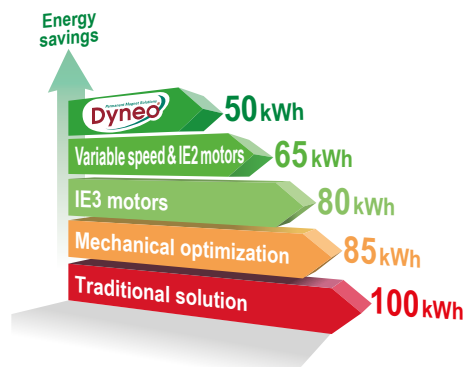

*Dyneo® motors are compact and provide high power density compared to standard motors')*





## Permanent magnet technology for maximum energy efficiency

Nidec's Permanent Magnet technology Dyneo® solutions provide high power density, compact and incredibly efficient solutions with minimal investment. Light weight chassis also means less strain on the crane structure, helping to optimize performance and longevity.

Permanent magnet generators are used in crane systems to ensure optimum electricity production occurs in line with the actual requirements of the crane load or movements.



## RISGA - Fuel saving and power generation solution for RTGs and MHCs

Diesel generators onboard RTG and MHC cranes run at constant speed to supply the drive system and auxiliaries (such as lighting and heating) whether in operation or when idle. RISGA is a low cost, compact solution which manages the generator, allowing its speed to be reduced when idling but still supplying the auxiliaries, saving around 50 % of fuel consumption when idle (approximately 25 % overall).

Key benefits are:

- Reducing operational costs
- Increase crane productivity reducing the amount of refuel stops
- Reduced wear, extending the life of the diesel engine, generator and electrical auxiliaries
- Reduced emissions and noise
- Quick ROI, often in 1 to 2 years
- Easy to install in new or existing crane cabinets with minimum downtime

# Optimized and efficient control of port equipment

Our control system and CMS incorporates industry-leading software into the drive and motor solution, monitoring the physical and operating conditions of port equipment on a real-time basis. It can be used to optimize the equipment's movements and trajectories, relieving the operator of delicate and repetitive tasks, while improving position location.

## Equipment control system

Nidec's design is based on extensive experience in port equipment automation solutions in container, dry bulk terminal and port material handling.

The equipment control system architecture uses a master controller to coordinate the I/O devices and to communicate with the networked drives and human interfaces, assisting the equipment operator during operations which result in increased productivity. Nidec has adopted industry standards such as CODESYS to help the integration of these complex control systems in port logistics applications.

The control system software provides graphical programming languages making the master controller easy-to-use and powerful. Connectivity options provide seamless integration with other port logistics equipment via fast communication systems based on Ethernet or via common fieldbuses.

Nidec control systems minimize space requirements and cost, while providing the highest control accuracy.





## Crane Management System (CMS)

Mounted in the operator cabin, electric house, ground station or the maintenance or operations office; the CMS provides a selection of displays providing both real-time crane operating data and machine diagnostic data. The CMS can be used to operate the crane, schedule maintenance, diagnose crane faults, reconfigure the drives and provide production data. Data analysis is simplified using a trend recorder, which display real-time and historical data. RCMS reduces crane downtime and maintenance costs even more by reducing the need to visit the equipment by maintenance or operations team. Also, access to this system is available remotely to onsite maintenance teams or to our expert teams via the Internet.

## Differential Global Positioning System (DGPS)

Our DGPS is a GPS-based automatic steering and yard management system for port applications, which can be used on SC, RTG and RMG cranes. The system offers satellite guided relative positioning (differential) mode, giving excellent accuracy with minimal positioning error when manoeuvring cranes and tracking container locations. Accurate guidance allows operators to stack and organize containers in the most efficient way to plan for quick transportation to their destination.

## Easy-to-use and innovative system interfacing

Our latest generation products, HMIs and software tools, draws from extensive user research and human centered design principles. System integration, commissioning, optimization and monitoring are now even more intuitive, due to our use of:

- Industry standard communication protocols and open programming environments for seamless integration with terminal operation systems and other port equipment.
- Intuitive graphical software tools enhance and simplify drive system commissioning and maintenance.
- Matched drive and motor mapping for automatic optimization.
- Use of popular SD cards in drives for quick and easy parameter and program storage.
- Remote control monitoring, enhancing crane up-time and performance.



# Nidec customized services and support to ensure optimized operation for the life time of your system

An extensive global service team offers support to Nidec customers whenever and wherever it is needed. The Nidec service team consists of a large global network, often allowing customers to receive locally-based assistance. We also use remote diagnostic technology to monitor data, status, fault and performance with the goal to help the port maintenance team and to minimize equipment downtime.

Nidec engineers are highly trained in the service and maintenance of Nidec Automation Solutions, with particular emphasis on safety. We ensure responsible and dedicated support.



## Nidec offers you different levels of service to suit your needs

These comprise of:

- Remote technical service with in-house skills for services and training
- On-site technical service tailored to customer needs
- Periodic inspections
- Supervision of maintenance
- Scheduled and preventive maintenance
- Express Availability service for spare parts
- Repair services
- Standard training programs
- On-site training for operators and maintenance & safety training provided to minimize absence periods of valuable people

At the highest level, we can assure optimum operative availability of automation equipment through planned proactive maintenance. This is supported by our service strategy and the services of experienced engineers to monitor and inspect your equipment.



**CONTROL TECHNIQUES**<sup>™</sup>

**LEROY-SOMER**<sup>™</sup>

[www.nidecautomation.com](http://www.nidecautomation.com)

**Connect with us at:**

[twitter.com/ctandls](https://twitter.com/ctandls)

[facebook.com/ctandls](https://facebook.com/ctandls)

[youtube.com/c/controltechniquesandleroyssomer](https://youtube.com/c/controltechniquesandleroyssomer)

[theautomationengineer.com](http://theautomationengineer.com) (blog)



**Nidec**  
All for dreams

Control Techniques Limited. Registered Office: The Gro, Newtown, Powys SY16 3BE. Registered in England and Wales. Company Reg. No. 01236886.

Moteurs Leroy-Somer SAS. Headquarters: Bd Marcellin Leroy, CS 10015, 16915 Angoulême Cedex 9, France. Share Capital: 65 800 512 €, RCS Angoulême 338 567 258.