

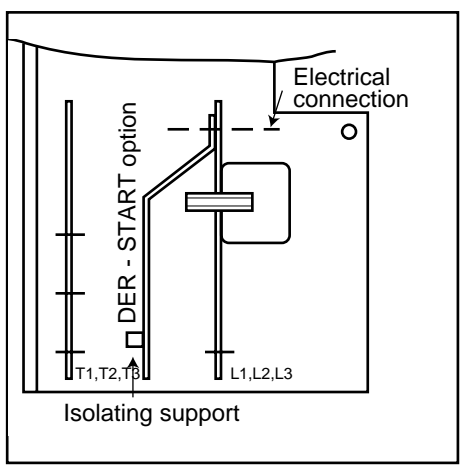

Ref. 2044 GB - 4.33 / a - 11.00

CE



DER - START

Bypass kit

DIGISTART STV 2313

Installation

DER - START

1 - GENERAL INFORMATION

1.1 - Use

Once the motor has started, this kit is designed to close a contactor at the STV 2313 thyristor terminals while maintaining the protection and monitoring functions integral to the STV 2313.

1.2 - Kit composition

• DER - START 1 for STV 2313 365

Description	Quantity
Copper connection bar	3
Isolating support	1
TH M6 x 16 screws	2
TH M6 x 20 screws	3
M6 contact washer	5
TH M8 x 20 screws	6
M8 collar nut	6
M8 contact washer	6
TH M12 x 35 screws	3
M12 nut	3
M12 contact washer	6

• DER - START 2 for STV 2313 530

• DER - START 3 for STV 2313 700 to 900

Description	Quantity
Copper connection bar	3
Isolating support	1
TH M6 x 16 screws	2
TH M6 x 20 screws	9
M6 collar nut	9
M6 contact washer	14
TH M6 x 25 screws	3
TH M12 x 35 screws	3
M12 nut	3
M12 contact washer	6

DER - START

2 - INSTALLATION

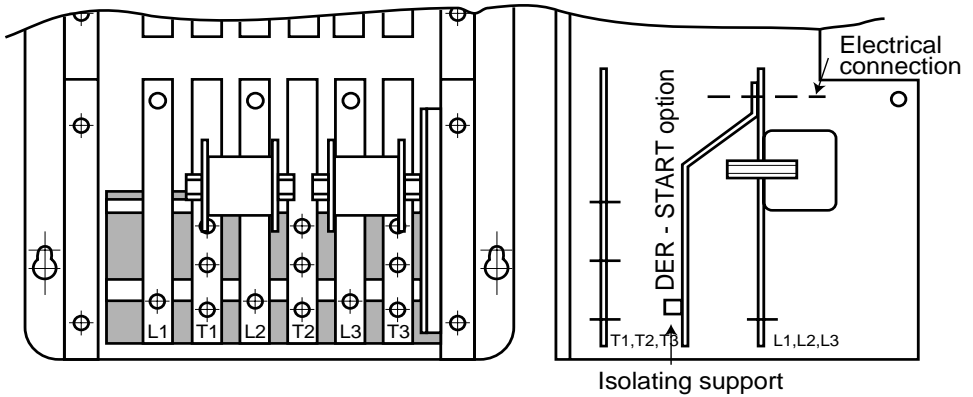

Instructions

- 1 - Fix the isolating support on the STV 2313 cheeks (the holes are located 100 mm from the bottom edge of the product and 100 mm from the back).
- 2 - Insert the 3 bars, then connect them with 2 or 3 screws each (depending on the rating).
- 3 - Fix the bars on the support.

- 4 - Wire the contactor onto these bars. By retaining the CTs, current measurement is retained, and hence also the DIGISTART protection.

Note: Remove the protective cover from the power section before performing these operations.

3 - WIRING THE BYPASS CONTACTOR

- Terminals D1, D2 and D3 represent the bars of the **DER - START** kit.

D1 is in phase with L1

D2 is in phase with L2

D3 is in phase with L3

- D1 - T1, D2 - T2 and D3 - T3 must be associated with the contactor terminals.

- Contactor pick-up is controlled by the "motor start complete" signal available on the STV 2313 programmable relay.

- Contactor drop-out is controlled by a **stop instruction and the interlock protection.**

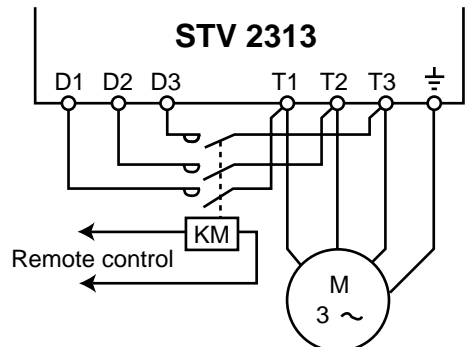



MOTEURS LEROY-SOMER 16015 ANGOULÊME CEDEX - FRANCE

RCS ANGOULÊME N° B 671 820 223

S.A. au capital de 131 910 700 F

<http://www.leroy-somer.com>