

LSRPM - PLSRPM



Synchronous permanent magnet motors

Installation and maintenance

LSRPM - PLSRPM

Synchronous permanent magnet motors

IMPORTANT

These symbols    appear in this document whenever it is important to take special precautions during installation, operation, maintenance or servicing of the motors.

It is essential that electric motors are installed by experienced, qualified and authorised personnel.

In accordance with the main requirements of EEC Directives, the safety of people, animals and property should be ensured when fitting the motors into machines.

Particular attention must be given to equipotential ground or earthing connections.

The following preliminary precautions must be taken before working on any stationary device:

- mains voltage disconnected and no residual voltage present
- careful examination of the causes of the stoppage (jammed transmission - loss of phase - coupure par protection thermique - défaut de lubrification...)



Even when not supplied with power, there is voltage at the terminals of a rotating synchronous motor with magnets. Accordingly, before carrying out any work check carefully that the motor is not rotating.



For dismantling the permanent magnet motor

Assembly or maintenance of the rotor must not be carried out by people with pacemakers or any other implanted medical electronic device.

The motor rotor contains a powerful magnetic field. When the rotor is separated from the motor, its field may affect pacemakers or disturb digital devices such as watches, mobile phones, etc.

LSRPM - PLSRPM

Synchronous permanent magnet motors

Dear Customer,

You have just acquired a LEROY-SOMER motor.

This motor benefits from the experience of one of the largest manufacturers in the world, using state-of-the-art technology in automation, specially selected materials and rigorous quality control. As a result, the regulatory authorities have awarded our motor factories **ISO 9001 - Edition 2008 international certification from the DNV**. Similarly, our environmental approach has enabled us to obtain **ISO 14001: 2004 certification**.

Products for particular applications or those designed to operate in specific environments are also approved or certified by the following organisations: **CETIM, LCIE, DNV, ISSEP, INERIS, CTICM, UL, BSRIA, TUV, CCC and GOST**, which check their technical performance against the various standards or recommendations.



We thank you for making this choice, and would ask you to read the contents of this manual.

By observing a few essential rules, you will ensure problem-free operation for many years.

LEROY-SOMER

CE conformity

Our motors conform to standard IEC 34, and therefore to the Low Voltage Directive 2006/95/EC, which is demonstrated by their marking with the symbol 

	
MOTEURS LEROY-SOMER USINE	
DECLARATION OF CONFORMITY AND INCORPORATION	
<p>LEROY-SOMER MOTORS declares that the components :</p> <p>conform to the harmonized standard EN 60 034 (IEC 34) and thus meet the essential requirements of Low Voltage Directive 2006/95/EC.</p> <p>The components thus defined also meet the essential requirements of the Electromagnetic Compatibility Directive 2004/108/EC, if they are used within certain voltage limits (IEC 34).</p> <p>By reason of such conformity, these component ranges may be used in machines governed by the Machinery Directive 2006/42/EC, provided that the method of integration or incorporation and/or assembly conforms to at least the regulations in standard EN 60204 "Electrical Equipment for Machinery" and our installation manual.</p> <p>The components defined above must not be installed unless the machine in which they are incorporated has been declared as conforming to the relevant direct.</p> <p>N.B. : When components are powered by specially adapted electronic converters and/or servo-controlled by electronic control-command devices, they must be installed by a professional person. This person must take responsibility for complying with the regulations concerning electromagnetic compatibility in the country where the machine is used.</p>	
Declaration made by	At
Quality Director	On
MOTEURS LEROY-SOMER	Signature
 <small>MOTEURS LEROY-SOMER (SEDE SOCIAL 80 MARCELLIN LEROY - 10151 ANDOULLENE CODEX) SOCIETE ANONYME AU CAPITAL DE 411 000 000 F - RCS ANDOULLENE 9 338 957 238 - SIRET 338 957 238 80011</small>	

NOTE :

LEROY-SOMER reserves the right to modify the characteristics of its products at any time in order to incorporate the latest technological developments. The information contained in this document may therefore be changed without notice.

Copyright 2003 : LEROY-SOMER MOTORS

This document is the property of LEROY-SOMER.

It may not be reproduced in any form without prior authorisation.

All brands and models have been registered and patents applied for.

LSRPM - PLSRPM

Synchronous permanent magnet motors

CONTENTS

1 - RECEIPT	5
1.1 - Identification	5
1.2 - Storage	6
2 - ASSEMBLY AND COMMISSIONING RECOMMENDATIONS	6
2.1 - Checking the insulation	6
2.2 - Location - ventilation	7
2.3 - Coupling	7
2.4 - Electrical protection of the motors	10
2.5 - Connection to a drive	12
3 - ROUTINE MAINTENANCE	18
3.1 - Checks	18
3.2 - Bearings and lubrication	18
3.3 - Bearing maintenance	19
4 - PREVENTIVE MAINTENANCE	19
5 - TROUBLESHOOTING GUIDE	20
6 - CORRECTIVE MAINTENANCE: GENERAL	21
6.1 - Dismantling the motor	21
6.2 - Checks before reassembly	21
6.3 - Mounting the bearings on the shaft	21
6.4 - Reassembling the motor	21
6.5 - Reassembling the terminal box	21
6.6 - Checking the Hall effect sensors	21
7 - POSITION OF LIFTING RINGS	22
8 - SPARE PARTS	23
9 - DISMANTLING – REASSEMBLY	24
9.1 - LSRPM 90 L motors	24
9.2 - LSRPM 100 L motors	26
9.3 - LSRPM 132 M motors	28
9.4 - LSRPM 160 MR/LR motors	30
9.5 - LSRPM 200, LSRPM 225, LSRPM 250, LSRPM 280 SC/SD/MD motors	32
9.6 - LSRPM 280 MK1, LSRPM 315 motors	34
9.7 - PLSRPM 315 LD motors	36
10 - APPENDICES	38

LSRPM - PLSRPM

Synchronous permanent magnet motors

1 - RECEIPT

On receipt of your motor, check that it has not suffered any damage in transit.

If there are obvious signs of damage, contact the carrier (you may be able to claim on their insurance) and after a visual check, turn the motor to detect any malfunction.

1.1 - Identification

As soon as you receive the motor, check that the nameplate on the machine conforms to your order.

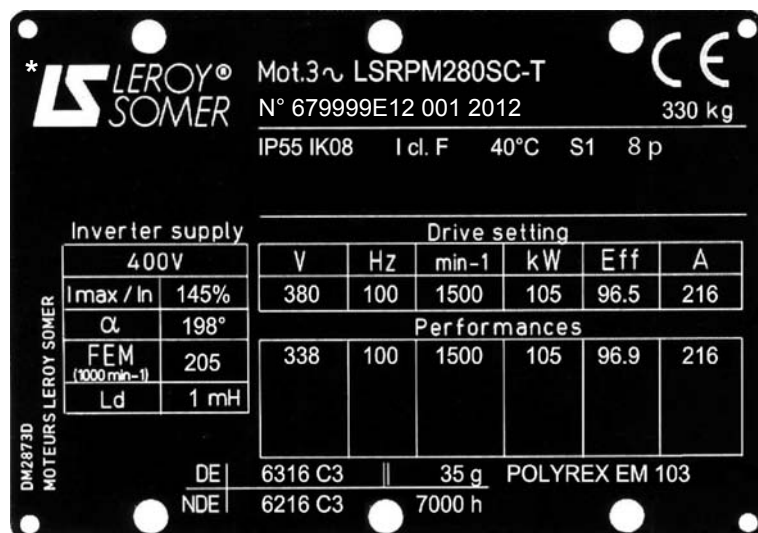

* Other logos can be provided as an option: prior agreement is essential before ordering.

Definition of symbols used on nameplates:



Legal mark of conformity of product to the requirements of European Directives.

MOT 3 ~ : 3-phase AC motor

LSRPM : Series

280 : Frame size

SC : Housing designation and manufacturer code

T : Impregnation index

Motor

679999 : Motor serial number

E : Month of production

12 : Year of production

001 : Serial number

IP55 IK08 : Degree of protection

(I) cl. F : Insulation class F

40°C : Contractual ambient operating temperature

S : Duty

% : Operating factor

8 p : Polarity

...d/h : Number of cycles per hour

kg : Weight

FEM : Electromotive force

α : Phase angle

Ld : Transient inductance

Drive settings : Parameters to enter in the drive

Performances : Motor characteristics

Hz : Supply frequency

min⁻¹ : Revolutions per minute

kW : Rated power

Eff : Efficiency

A : Rated current

Bearings

DE : Drive end

Drive end bearing

NDE : Non drive end

Bearings at non drive end

RI: Insulated bearings

35 g : Amount of grease at each regreasing (cm³)

7000 h at 1500 min⁻¹ : Regreasing interval (in hours) for θamb

POLYREX EM 103 : Type of grease

LSRPM - PLSRPM

Synchronous permanent magnet motors

1.2 - Storage

Prior to commissioning, machines must be stored:

- protected from humidity: at relative humidity levels above 90%, the machine insulation can drop very rapidly, to just above zero at around 100%. The state of the anti-rust protection on unpainted parts should be monitored.

For prolonged storage longer than 3 months, place the machine in a sealed waterproof covering (for example heatshrunken plastic) containing sachets of desiccant corresponding to the volume and the degree of humidity of the location:

- Protected from frequent significant variations in temperature, to avoid the risk of condensation. During storage the drain plugs must be removed to allow condensation water to escape. This location must be dry and protected from harsh weather conditions, cold (temperature between - 15°C and + 80°C), frequent temperature variations (to prevent the risk of condensation), and free from vibration, dust and corrosive gases.

- If the area is subject to vibration, try to reduce the effect of this vibration by placing the motor on a damping support (rubber plate or similar).

Turn the rotor a fraction of a turn once a fortnight to prevent the bearing rings from becoming marked.

- Do not remove the rotor locking device (where there are roller bearings).

Even if the motor has been stored in the correct conditions, certain checks must be carried out before it is started up:

Greasing

Bearings which cannot be regreased

Maximum storage: 3 years. After this time, replace the bearings (see section 6.3).



Bearings which can be regreased

	Grease grade 2	Grease grade 3	
Storage period	less than 6 months	less than 1 year	The motor can be commissioned without regreasing
	more than 6 months less than 1 year	more than 1 year less than 2 years	Regrease before commissioning, as described in section 3.1
	more than 1 year less than 5 years	more than 2 years less than 5 years	Dismantle the bearing - Clean it - Replace the grease completely
	more than 5 years	more than 5 years	Change the bearing - Regrease it completely

Greases used by LEROY-SOMER : POLYREX EM 103

2 - ASSEMBLY AND COMMISSIONING RECOMMENDATIONS

In all cases, compatibility of the motor and its environment must be guaranteed before its installation and also throughout its life.

  **Electric motors are industrial products. They must therefore be installed by qualified, experienced and authorised personnel. The safety of people, animals and property must be ensured when fitting the motors into machines (please refer to current standards).**

2.1 - Checking the insulation

 **Before starting the motor, it is advisable to check the insulation between the phases and earth, and between phases.**

This check is essential if the motor has been stored for longer than 6 months or if it has been kept in a damp atmosphere.

This measurement must be carried out using a megohmmeter at 500 V DC (do not use a magnetolectric system). It is better to carry out an initial test at 30 or 50 volts and if the insulation is greater than 1 megohm, carry out a second test at 500 volts for 60 seconds. The insulation value must be at least 10 megohms in cold state.

If this value cannot be achieved, or if the motor may have been splashed with water or salt spray, or kept for a long period in a very humid place or if it is covered with condensation, it is advisable to dry the stator for 24 hours in a drying oven at a temperature of between 110°C and 120°C.

If it is not possible to place the motor in a drying oven:

- Switch on the motor, with the rotor locked, at 3-phase AC voltage reduced to approximately 10% of the rated voltage, for 12 hours (use an induction regulator or a reduction transformer with adjustable outlets).

Or supply the 3 phases in series with a DC current, with the voltage at 1 to 2% of the rated voltage (use a DC generator with independent excitation or batteries for motors of less than 22 kW).

- NB: The AC current must be monitored using a clamp ammeter, and the DC current using a shunt ammeter. This current must not exceed 60% of the rated current. It is advisable to place a thermometer on the motor housing:

if the temperature exceeds 70°C, reduce the indicated voltage or current by 5% of the original value for every 10° difference. While it is drying, all the motor orifices must be open (terminal box, drain holes).

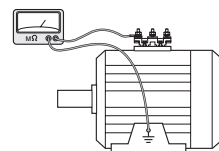

 **Warning: If the high voltage test which was carried out at the factory before despatch needs to be repeated, it should be performed at half the standard voltage, i.e.: 1/2 (2U + 1 000V). Check that the capacitive effect resulting from the high voltage test is eliminated before connecting the terminals to earth.**

LSRPM - PLSRPM

Synchronous permanent magnet motors

⚠ Prior to commissioning for all motors:
 Rotate the motor at no load (no mechanical load) for 2 to 5 minutes, checking that there is no abnormal noise. If there is any abnormal noise, see section 5.

2.2 - Location - ventilation

2.2.1 - TEFV motors

Our motors are cooled in accordance with method IC 411 (standard IEC 34-6), i.e. «machine cooled by its surface, using the ambient fluid (air) flowing along the machine».

The fan at the non drive end cools the motor. Air is sucked in through the grille of a fan cover (which provides protection against the risk of direct contact with the fan in accordance with standard IEC 34-5) and blown along the housing fins to ensure thermal equilibrium of the motor whatever the direction of rotation.

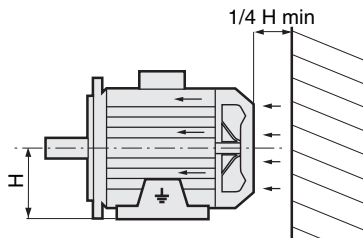

2.2.2 - Drip-proof motors

Location ventilation

Our motors are cooled in accordance with method IC 01 (standard IEC 34-6), i.e. «machine cooled by means of the ambient fluid (air) circulating inside the machine».

A fan at the non-drive end cools the motor. Air is sucked in at the front of the motor and blown along the fan cover to ensure thermal equilibrium of the motor whatever the direction of rotation.

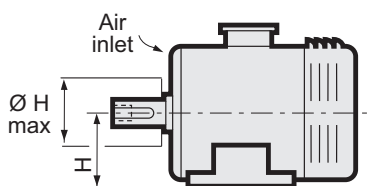

The motor must be installed in a ventilated place, with clearance for the air inlet and outlet.

Obstruction (clogging) - even accidental - of the ventilation circuit has an adverse effect on motor operation.

It is also necessary to check that the hot air is not being recycled. If it is, pipes must be provided for the intake of cold air and expulsion of hot air, in order to prevent abnormal motor temperature rise.

In this case, if the air is not circulated by an auxiliary fan, the dimensions of the pipes must be such that the pressure losses are negligible compared to those of the motor.

Positioning

The motor must be mounted in the position specified on the order, on a base which is rigid enough to prevent distortion and vibration.

Where the motor feet have six fixing holes, it is preferable to use those which correspond to the standard dimensions for the motor power rating (refer to the technical catalogue for induction motors), or, failing that, to those shown at B2.

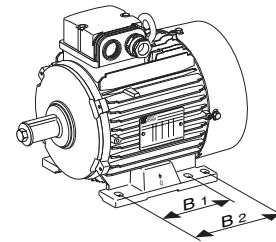

Provide easy access to the terminal box, the condensation drain plugs and, if appropriate, to the grease nipples.

Use lifting equipment which is compatible with the weight of the motor (indicated on the nameplate).

⚠ When the motor is fitted with lifting rings, they are for lifting the motor on its own and must not be used to lift the whole machine after the motor has been fitted to it.

Note 1: When installing a suspended motor, it is essential to provide protection in case the fixing breaks.

Note 2: Never stand on the motor.

2.3 - Coupling

Preparation

Rotate the motor before coupling to detect any possible fault due to handling.

Remove any protection from the shaft extension.

Note: The rotor magnets generate resistance to rotation.

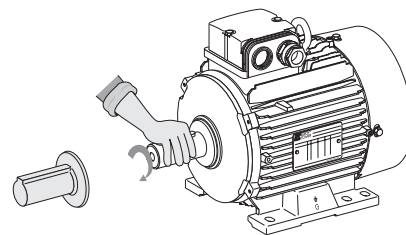

Drain off any condensation water which may have formed inside the motor by removing the plugs from the drain holes.

Rotor locking device

For made-to-order motors with roller bearings, remove the rotor locking device.

In exceptional circumstances when the motor has to be moved after the coupling device has been fitted, the rotor must be re-immobilised.

LSRPM - PLSRPM

Synchronous permanent magnet motors

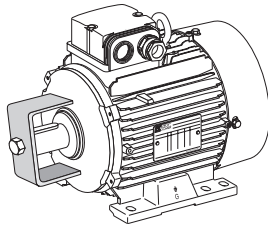

Balancing

Rotating machines are balanced in accordance with standard ISO 8821:

- Half-key when the shaft extension is marked H
- No key when the shaft extension is marked N
- Full key when the shaft extension is marked F

Any coupling element (pulley, coupling sleeve, slip-ring, etc) must therefore be balanced accordingly.

Motor with 2 shaft extensions:

If the second shaft extension is not used, in order to comply with the balancing class, the key or half-key must be fixed firmly in the keyway so that it is not thrown out during rotation (H or F balancing) and must be protected against direct contact.

! If a motor is started up without a coupling device having been fitted, carefully immobilise the key in its housing.

Beware of backdriving when the motor is switched off. The appropriate precautions must be taken:

- for pumps, a non-return valve must be installed.
- for mechanical devices, install a backstop or a holding brake.
- etc.

Tolerances and adjustments

The standard tolerances are applicable to the mechanical characteristics given in our catalogues. They comply fully with the requirements of IEC standard 72-1.

- Users must adhere strictly to the instructions provided by the transmission device supplier.
- Avoid impacts which could damage the bearings.

Use a spanner and the tapped hole of the shaft extension with a special lubricant (e.g. molykote grease) to make it easier to fit the coupling.

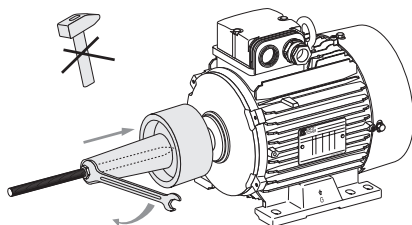

The hub of the transmission device must be:

- fully in contact with the shoulder of the shaft or, if this is missing, against the metal stop ring which forms a labyrinth seal and thus locks the bearing in place (do not crush the seal).

- longer than the shaft extension (2 to 3 mm) so that it can be tightened using a screw and washer. If it is not, a spacer ring must be inserted without cutting the key (if this ring is large, it must be balanced).

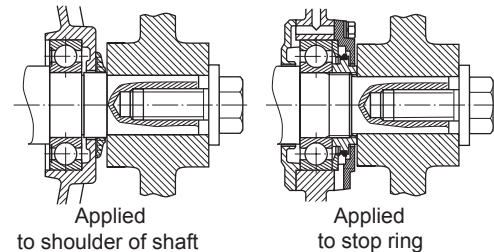

If there is a second shaft extension, it must only be used for direct coupling and the same recommendations must be followed.

! The 2nd shaft extension may also be smaller than the main shaft extension, and under no circumstances can it deliver torques greater than half the rated torque.

Inertia flywheels must not be mounted directly onto the shaft extension, but installed between end shields and connected by a coupling device.

Direct connection onto the machine

When mounted directly on the motor shaft extension of the moving device (pump or fan turbine), check that this device is perfectly balanced and that the radial force and the axial thrust are within the limits indicated in the catalogue for bearing performance.

Direct connection using a coupling sleeve

Selection of the coupling sleeve should take account of the rated torque to be transmitted and the safety factor dependent on the starting conditions for the electric motor.

The machines must be carefully aligned, so that any lack of concentricity and parallelism in the two parts of the coupling sleeve is compatible with the recommendations of the coupling sleeve manufacturer.

The two parts of the coupling sleeve should be provisionally assembled to make it easier to alter their relative position.

Adjust the parallel plane of both shafts using a gauge.

Measure the distance between the two coupling surfaces at one point on the circumference. Rotate them 90°, 180° and 270° in relation to this initial position, and measure each time.

The difference between the two extreme values of dimension «x» must not exceed 0.05 mm for standard couplings.

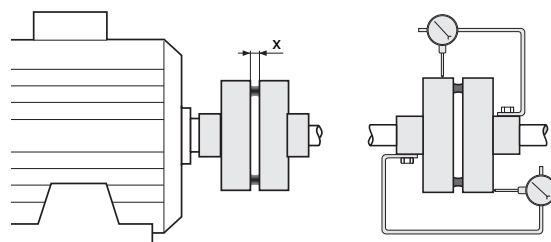

LSRPM - PLSRPM

Synchronous permanent magnet motors

To perfect this adjustment and at the same time check the concentricity of the two shafts, fit 2 gauges as shown in the diagram and slowly turn both shafts.

The differences registered by either shaft will indicate the need for an axial or radial adjustment if the difference exceeds 0.05 mm.

Direct connection using a rigid coupling sleeve

The two shafts must be aligned so as to adhere to the tolerances of the coupling sleeve manufacturer.

Maintain the minimum distance between the two shaft extensions to allow for expansion of the motor shaft and the load shaft.

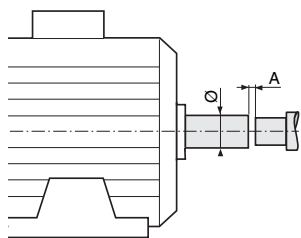

Ø (mm)	A (mm) min.
28 to 55	1
60	1.5
65	1.5
75 to 85	2

Transmission via belt pulleys (prohibited for Series 3 600 and 5500)

The user can choose the diameter of the pulleys. Cast iron pulleys with a diameter greater than 315 are not recommended for rotation speeds of 3000 min⁻¹. Flat belts cannot be used for rotation speeds of 3000 min⁻¹ or more.

Positioning the belts

So that the belts can be correctly positioned, allow for possible adjustment of approximately 3% with respect to the calculated distance E.

Force must never be used when fitting the belts. For notched belts, position the notches in the pulley grooves.

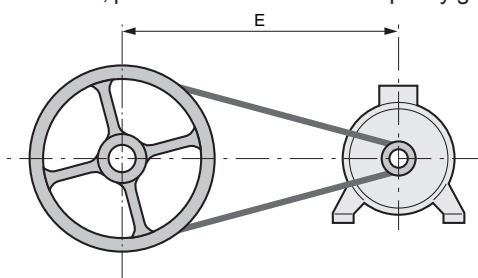

Aligning the pulleys

Check that the motor shaft is completely parallel with that of the receiving pulley.

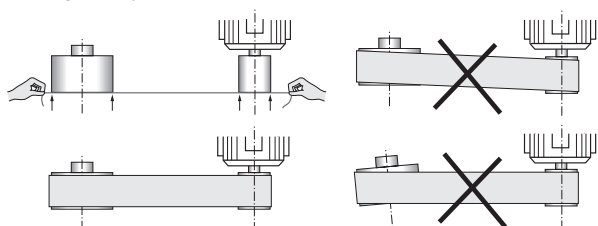

Protect all rotating devices before power-up.

Adjusting the tension of the belts

The tension of the belts must be adjusted very carefully in accordance with the recommendations of the belt supplier and the calculations made when the product was specified.

Reminder:

- tension too great = unnecessary force on the end shields which could lead to premature wear of the bearing unit (end shield-bearings) and eventually break the shaft.
- tension too low = vibration (wearing of the bearing unit).

Fixed distance between centres:

Place a belt tensioning pulley on the slack side of the belts:

- Smooth pulley on the outside of the belt
- Grooved pulley on the inside of the belts when using V-belts.

Adjustable distance between centres:

The motor is usually mounted on slide rails, which enables optimum adjustment of the pulley alignment and the belt tension.

Place the slide rails on a completely horizontal baseplate.

Lengthways, the position of the slide rails is determined by the length of the belt, and crossways by the pulley of the machine being driven.

Mount the slide rails firmly with the tension screws in the direction shown in the diagram (slide rail screw on the belt side between the motor and the machine being driven).

Fix the slide rails to the baseplate and adjust the belt tension as before.

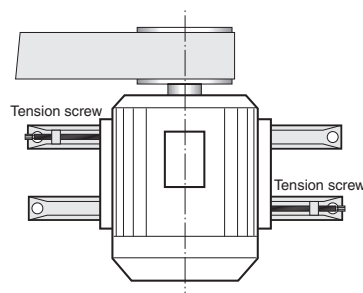

LSRPM - PLSRPM

Synchronous permanent magnet motors

Optional: Standard slide rails (conforming to standard NFC 51-105)

These steel slide rails are supplied with tension screws and 4 nuts and bolts for fixing the motor onto the slide rails, but the fixing bolts for the slide rails are not supplied.

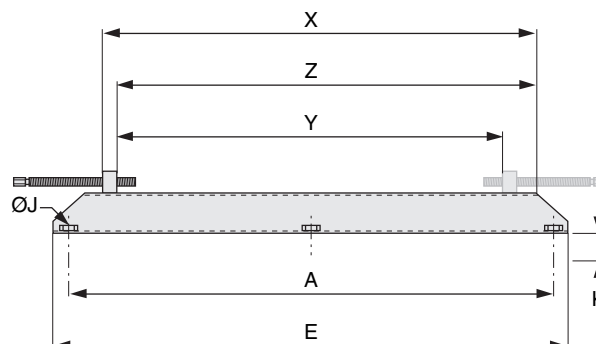
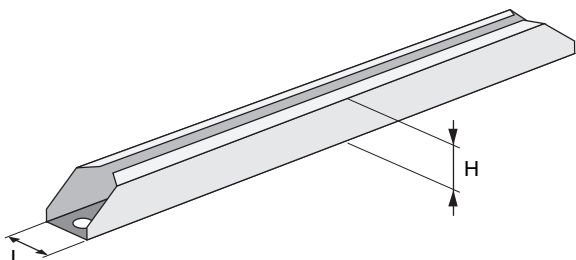

Motor frame size	Type of slide rail	Dimensions								Weight per pair of slide rails (kg)	
		A	E	H	K	L	X	Y	Z		ØJ
90	G 90/8 PM	355	395	40	2.5	50	324	264	294	13	3
100 and 132	G 132/10 PM	420	530	49.5	7	60	442	368	405	15	6
160	G 180/12 PM	630	686	60.5	7	75	575	475	525	19	11
200 and 225	G 225/16 PF	800	864	75	28.5	90	-	623	698	24	16
250 and 280	G 280/20 PF	1000	1072	100	35	112	-	764	864	30	36
315	G 355/24 PF	1250	1330	125	36	130	-	946	1064	30	60

2.4 - Electrical protection of the motors

2.4.1 - Recommendations for variable speed

Special precautions must be taken when using synchronous motors powered via a frequency inverter: during prolonged operation at low speed, cooling efficiency is greatly diminished. It is therefore advisable to install a forced ventilation unit that will produce a constant flow of air independently of the motor speed.

In prolonged operation at high speed, the fan may make excessive noise. It is again advisable to install a forced ventilation unit.

Caution: Make sure you comply with the supply voltages specified on the motor rating plate ($\pm 10\%$). Outside this range, there is a risk of temperature rise.

2.4.2 - Thermal protection

The motors are protected by the variable speed drive, placed between the isolating switch and the motor.

Adjusting the thermal protection

It must be set to the value of the current shown on the motor nameplate for the voltage and frequency.

The drive provides total protection of the motor against mechanical overloads.

Built-in indirect thermal protection

The motors are fitted with PTC sensors as standard. As an option specific sensors can be fitted on the motor to monitor temperature changes at «hot spots»:

- overload detection,
- cooling check,
- monitoring strategic points for maintenance of the installation.

It must be emphasized that these sensors cannot be used to carry out direct adjustment of the operating cycle.

LSRPM - PLSRPM

Synchronous permanent magnet motors

Type	Operating principle	Operating curve	Breaking capacity (A)	Protection provided	Mounting Number of devices*
Normally closed thermal protection PTO	Bimetallic strip indirectly heated, with normally closed (NC) contact 		2.5 A at 250 V with $\cos \varphi 0.4$	General monitoring for non-transient overloads	Mounting in control circuit 2 or 3 in series
Normally open thermal protection PTF	Bimetallic strip indirectly heated, with normally open (NO) contact 		2.5 A at 250 V with $\cos \varphi 0.4$	General monitoring for non-transient overloads	Mounting in control circuit 2 or 3 in parallel
Positive temperature coefficient thermistor CTP	Non-linear variable resistor, indirectly heated 		0	General monitoring for transient overloads	Mounted with associated relay in control circuit 3 in series
Temperature sensor KT Y	Linear variable resistor, indirectly heated		0	Continuous monitoring with high accuracy at key hot spots	Mounted in control boards with associated reading equipment (or recorder) 1 per hot spot
Thermocouples T ($T < 150\text{ }^{\circ}\text{C}$) Constantan copper K ($T < 1000\text{ }^{\circ}\text{C}$) Copper Copper-nickel	Peltier effect		0	Continuous monitoring at regular intervals at hot spots	Mounted in control boards with associated reading equipment (or recorder) 1 per hot spot
Platinum temperature sensor PT 100	Linear variable resistor, indirectly heated		0	Continuous monitoring with high accuracy at key hot spots	Mounted in control boards with associated reading equipment (or recorder) 1 per hot spot

- NRT : Nominal running temperature.

- The NRTs are chosen according to the position of the sensor in the motor and the temperature rise class.

* The number of devices relates to the winding protection.

Alarm and early warning

All protective equipment can be backed up by another type of protection (with a different NRT). The first device will then act as an «early warning» (light or sound signals given without shutting down the power circuits), and the second device will be the alarm (shutting down the power circuits).



Warning: the motor may remain powered-up, depending on the type of protection. Ensure that the mains supply is disconnected before any work is carried out in the terminal box or in the cabinet.

Protection against condensation: space heaters

Identification: 1 red label

A glass fibre flexible resistor is fixed on 1 or 2 coil end turns. This resistor heats the machines when stopped and thus prevents condensation inside the machines.

Power supply: 230 V single-phase unless otherwise specified by the customer.

If the drain plugs at the bottom of the motor were not removed at the time of installation, they must be opened approximately every 6 months.



Warning: check that the space heaters are powered down before any work is carried out in the terminal box or in the cabinet.

LSRPM - PLSRPM

Synchronous permanent magnet motors

2.5 - Connection to a drive

2.5.1 - Terminal box

Placed as standard on the top of the motor near the drive end, for forms IM B3 and B5, the terminal box has IP 55 protection. Warning: The position of the terminal box cannot be easily modified, even with flanged motors, as the condensation drain holes must be at the bottom.

Using a cable gland (NFC 68 311 and 312 standards)

If the position of the cable gland has not been correctly specified on the order, or is no longer suitable, the symmetrical construction of the terminal box enables it to be turned in any of the 4 directions except for position (2) on flange-mounted motors (B5).

A cable gland must never open upwards.

Check that the incoming bend radius of the cables prevents water entering via the cable gland.

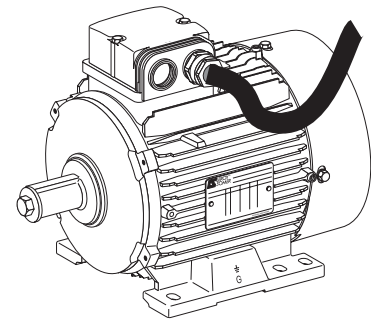
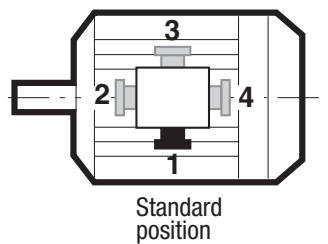
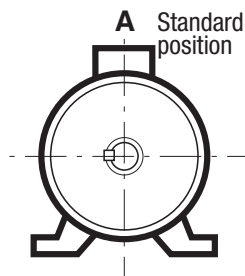

Motors are supplied as standard with terminal boxes pre-drilled and threaded without cable glands.

Tightening capacity of cable glands (NFC 68 311 and 312 standards)

Adapt the cable gland and its reducer, if fitted, to the diameter of the cable being used. In order to maintain the motor's original IP55 protection, it is essential to ensure the cable gland provides a total seal by tightening it correctly (so that it cannot be unscrewed by hand).

When there are several cable glands and some are not being used, ensure that they are always covered and tighten them so that they also cannot be unscrewed by hand.

Type and cable size capacity of cable glands

Cable gland type	Cable size capacity	
	Min. cable Ø (mm)	Max. cable Ø (mm)
ISO 16	6	11
ISO 20	7.5	13
ISO 25	12.5	18
ISO 32	17.5	25
ISO 40	24.5	33.5
ISO 50	33	43
ISO 63	42.5	55

In certain applications, it is necessary for there to be earth continuity between the cable and the motor earth to ensure protection of the installation in accordance with the EMC directive, 89/336/EEC. A cable gland option with anchorage on armoured cable is therefore available across the whole range of synchronous motors with magnets.

2.5.2 - Cross-section of the power supply cables

The higher the current, the greater the voltage drop in the cables (standard NFC 15.100 or end user's national standard). The voltage drop must therefore be calculated **for the motor rated current indicated on the nameplate** and acceptance will depend on the application and the type of cable.

LSRPM - PLSRPM

Synchronous permanent magnet motors

2.5.3 - Connections

Motors

Frame size ≤ 160

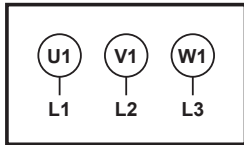

Frame size > 160

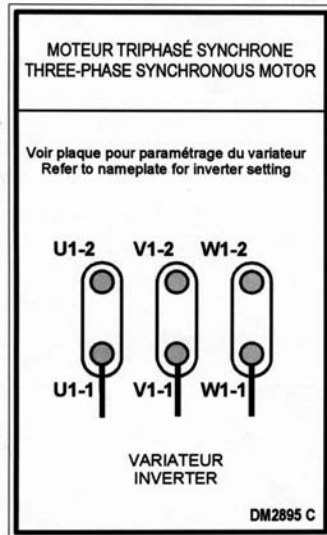

Hall effect sensor

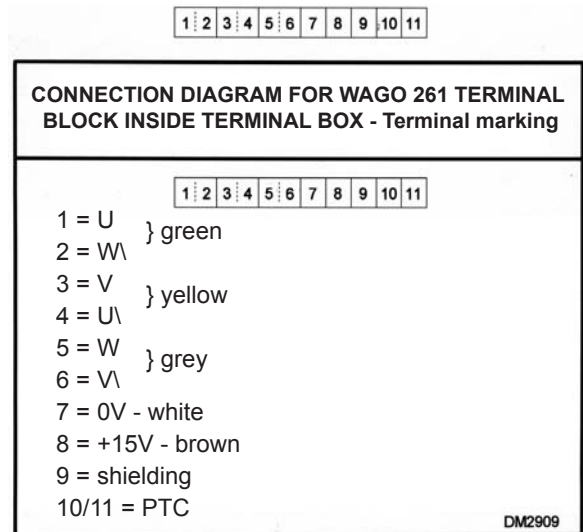

Warning: do not change the connection without consulting your LS contact.

Incremental encoder with UVW commutation channels

Function	U	U/	V	V/	W	W/	A	Z	Z/	A/	B	B/	Vcc	Gnd
Wire	White-Green	White-Pink	White-Yellow	White-Blue	White-Grey	White-Brown	Green	Grey	Red	Pink	Yellow	Blue	Brown	White
M23 17-pin	4	5	6	7	8	9	10	11	12	13	14	15	16	17

Pins 1 to 3 are not connected. The cable general shielding is connected to the connector casing.

Forced ventilation

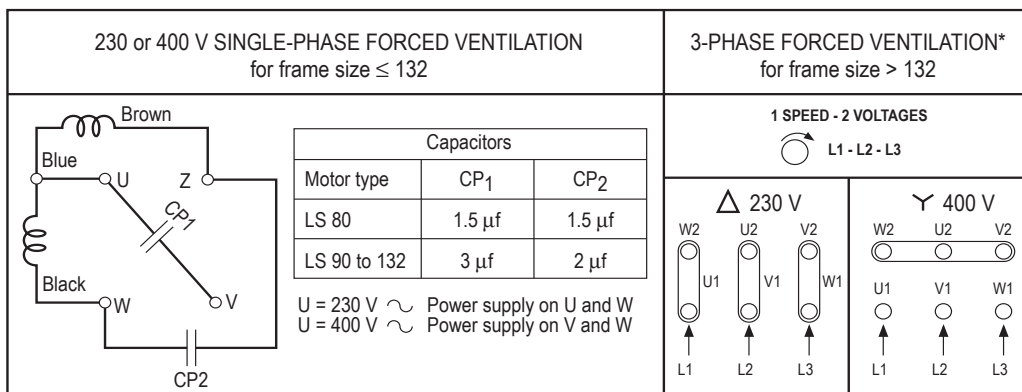

*for 4500 and 5500 rpm, contact the factory

LSRPM - PLSRPM

Synchronous permanent magnet motors

Brake

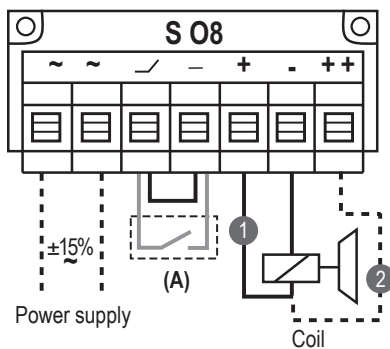

Power supply	Coil	Wiring*
400V AC	180V DC	①
230V AC	180V DC	②

*depending on power supply and coil

PTC sensors

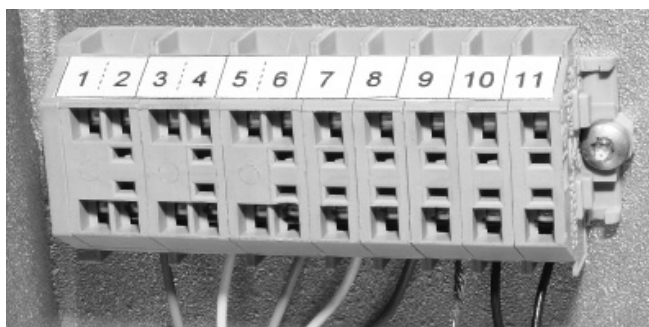

Connection of PTC sensors
Terminal numbers: 10 and 11

LSRPM - PLSRPM

Synchronous permanent magnet motors

2.5.4 - Connecting with feedback via encoder with commutation channels or hall effect sensor, controlled by a POWERDRIVE or POWERDRIVE FX drive

Encoder with commutation channels

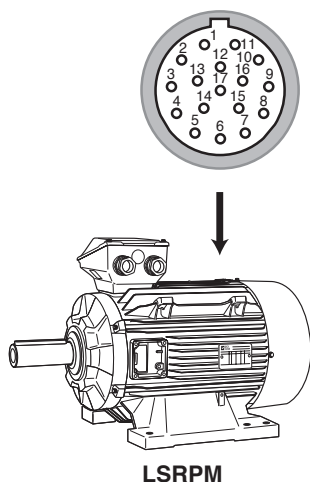

17-pin connector on encoder end (male plug)		MD/MDX-Encoder terminal block (3)
No.	Designation	Designation
1	x	x
2	x	x
3	x	x
4	U or S1	U
5	U\ or S1\	U\
6	V or S2	V
7	V\ or S2\	V\
8	W or S3	W
9	W\ or S3\	W\
10	A	A
11	C or O or Z	x
12	C\ or O\ or Z\	x
13	A\	A\
14	B	B
15	B\	B\
16	+5V or +15V	+
17	0V	-
Shielding (2)		

MD/MDX-ENCODER (3)



Use shielded cable on each pair (U,U\), (V,V\)...
The thermal sensor is connected in the motor terminal box (1)

Hall Effect sensor

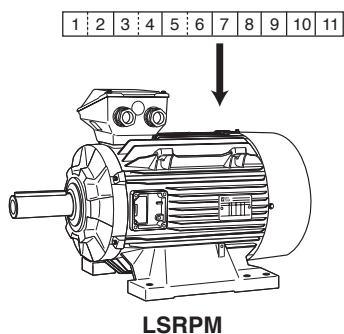

11-pin terminal block on Hall effect sensor end		MD/MDX-Encoder terminal block (3)
No.	Designation	Designation
1	U	U
2	W\	W\
3	V	V
4	U\	U\
5	W	W
6	V\	V\
7	0V	-
8	+15V	+
9	Shielding	
10	Motor thermal sensor (1)	T1
11		T2

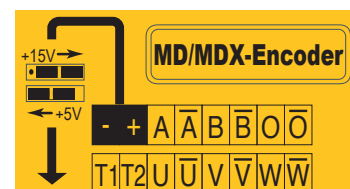

Use shielded cable on each pair (U,U\), (V,V\)...

(1) The thermal sensor connected in the motor terminal box should be connected to terminals T1, T2 of the MD/MDX-Encoder option (see manuals drive).

(2) Connect the shielding 360° round the connector.

(3) Powerdrive option used to manage the motor speed feedback.

LSRPM - PLSRPM

Synchronous permanent magnet motors

2.5.5 - Connecting with feedback via hall effect sensor, controlled by a UNIDRIVE SP drive

Drive off, check that...

- The order of the motor phases is respected.
- The wiring from the sensor to UT02 conforms to section L11 of manual 3616.
- The connections have been made as indicated below, depending on which motor is used.

1 2 3 4 5 6 7 8 9 10 11

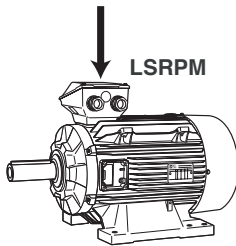

11-pin terminal block on Hall effect sensor end		UT02 terminal block	
1	U	3	U
2	W\	x	x
3	V	4	V
4	U\	x	x
5	W	5	W
6	V\	x	x
7	0V	2	0V
8	+15V	1	+15V
9	Shielding	⊥	⊥
10	Motor thermal sensor (*)	x	x
11			

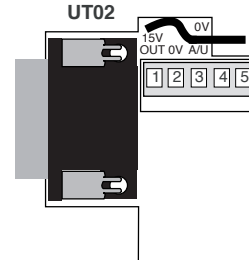

(*) Connect to terminals 8 and 11 of the drive terminal block

- The drive is disabled (terminal 31 not supplied).
- The run command has not been enabled.

2.5.6 - Connecting with feedback via encoder with commutation channels, controlled by a UNIDRIVE SP drive

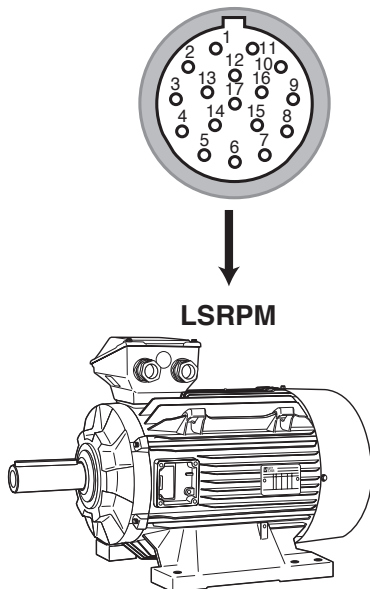

17-pin connector on encoder end (male plug)		15-pin connector on drive end
No.	Designation	No.
1	x	x
2	x	x
3	x	x
4	U or S1	7
5	U\ or S1\	8
6	V or S2	9
7	V\ or S2\	10
8	W or S3	11
9	W\ or S3\	12
10	A	1
11	C or O or Z	5
12	C\ or O\ or Z\	6
13	A\	2
14	B	3
15	B\	4
16	+5V or +15V	13
17	0V	14
	Shielding (2)	(3)

Use shielded cable on each pair. The thermal sensor is connected in the motor terminal box (1)

- (1) The thermal sensor connected in the motor terminal box should be connected to terminals 8 and 11 of the drive control terminal block. To modify sensor control, see parameter **7.15 (0.21)**.
- (2) Connect the shielding 360° round the connector.
- (3) Connect the shielding 360° round the shielding connection holder.

LSRPM - PLSRPM

Synchronous permanent magnet motors

2.5.7 - Direction of rotation

 **Warning, to reverse the direction of rotation, refer to the manual for the corresponding drive.**

Warning: motor with backstop: starting in the wrong direction destroys the backstop (see arrow on motor housing).
If the motor is fitted with accessories (thermal protection or space heater), these must be connected on screw terminals or terminal blocks with labelled wires (see section 2.4).

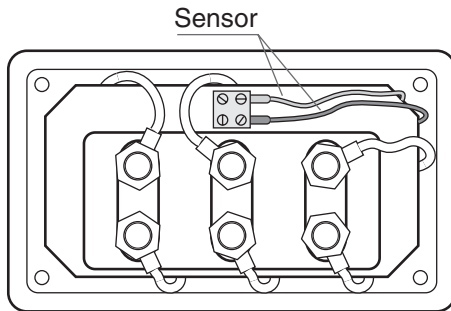

Tightening torque (N.m) on the terminal block nuts

Terminal	M4	M5	M6	M8	M10	M12	M14	M16
Steel	2	3.2	5	10	20	35	50	65
Brass	1	2	3	6	12	20	-	50

If using cables without connectors, attach yoke joint.
If any nuts on the brass terminal block are lost, they must be replaced by brass nuts, not steel ones.
When closing the box, ensure that the seal is correctly positioned.

 **As a general rule, check that no nut, washer or other foreign body has fallen into or come into contact with the winding.**

2.5.8 - Earth terminal

This is located inside the terminal box. In some cases, the earth terminal may be located on one of the feet or one of the cooling fins (round motors). It is indicated by the symbol: 

 **It is compulsory to earth the motor. Earthing must be performed in accordance with current regulations (protection of workers).**

* If required, ask the supplier for this diagram, specifying the motor type and number (shown on the motor nameplate).

2.5.9 - Connecting the power supply cables to the terminal block

The cables must be fitted with connectors suitable for the cable cross-section and the terminal diameter.
They must be crimped in accordance with the connector supplier's instructions.
They must be connected with connector resting on connector (see diagrams below):

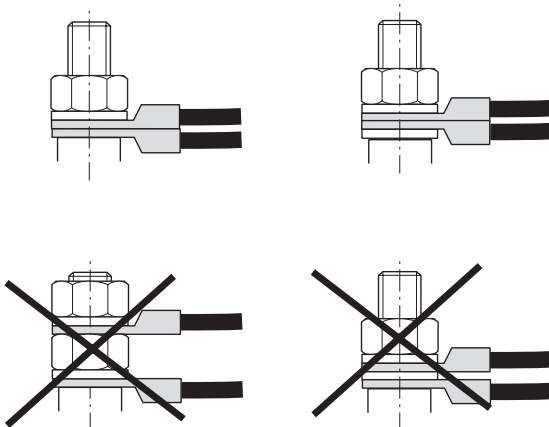

LSRPM - PLSRPM

Synchronous permanent magnet motors

3 - ROUTINE MAINTENANCE

3.1 - Checks

Running-in the bearings for series 4500 and 5500

When the motor is commissioned, and each time the bearings are replaced, the bearings must be run-in to obtain optimum service life.

Set the rotation speed to 4000 mn^{-1} , then each time the bearing temperature stabilises, increase the speed by 500 mn^{-1} , up to maximum speed. During this period, check that the bearing temperature remains below 110°C .

Checks during start-up,

Check: - noise
- vibration
- operation of the buttons/switches
- also check the current and voltage on the machine while it is operating with the rated load.

Checks after approximately 50 hours' operation,

Check: - that the screws fixing the motor and the coupling device are correctly tightened. In the case of chain or belt transmission, check that the tension is adjusted correctly.

Annual checks

Check: - that the screws fixing the motor are correctly tightened,
- the electrical connections
- check the vibration.

Cleaning

To ensure the motor operates correctly, remove any dust or foreign bodies which might clog the cover grille and the housing fins.

Precaution: before carrying out any cleaning operation check that the motor is completely sealed (terminal box, drain holes, etc.).

Dry cleaning (vacuuming or compressed air) is always preferable to wet cleaning.



Always clean at reduced pressure from the centre of the motor outwards to avoid introducing dust and particles under the seals.

Draining condensation water

Temperature variations cause condensation to form inside the motor, which must be removed before it adversely affects motor operation.

Condensation drain holes, located at the bottom of the motors (bearing in mind their operating position) are sealed with plugs which must be removed and then replaced every six months (if they were not replaced, the motor degree of protection would no longer be maintained).

Clean the holes and plugs before reassembly.

Note: In conditions of high humidity and significant temperature variations, a shorter period is recommended.

As long as it poses no risk to the protection of the motor, the condensation drain plugs can be removed.

3.2 - Bearings and lubrication

The bearings and type of grease nipple are defined in accordance with the table below:

Series	Frame size (mm)	Lubrication type N.D.E./D.E.	Ball bearing type	
			N.D.E.	D.E.
5500	≤ 160	Greased for life in the factory	standard	standard
	200	Bearings with grease nipples	insulated	insulated
4500	≤ 160	Greased for life in the factory	standard	standard
	200	Bearings with grease nipples	insulated	standard
	> 200	Bearings with grease nipples	insulated	insulated
3600	≤ 200	Greased for life in the factory	standard	standard
	> 200	Bearings with grease nipples	insulated for fr. size > 250	standard
3000	≤ 200	Greased for life in the factory	standard	standard
	> 200	Bearings with grease nipples	insulated for fr. size > 250	standard
2400	≤ 200	Greased for life in the factory	standard	standard
	> 200	Bearings with grease nipples	insulated for fr. size > 280SD	standard
1800	≤ 200	Greased for life in the factory	standard	standard
	> 200	Bearings with grease nipples	insulated for fr. size > 280	standard
1500	≤ 200	Greased for life in the factory	standard	standard
	> 200	Bearings with grease nipples	insulated for fr. size > 280	standard
900	≤ 200	Greased for life in the factory	standard	standard
	> 200	Bearings with grease nipples	standard	standard
750	≤ 200	Greased for life in the factory	standard	standard
	> 200	Bearings with grease nipples	standard	standard
375	≤ 160	Greased for life in the factory	standard	standard

3.2.1 - Type of grease

When the bearings are not greased for life, the type of grease is indicated on the nameplate.

As standard, this grease is EXXON MOBILE POLYREX EM103 and we recommend that this is used for subsequent lubrication.

Avoid mixing greases

3.2.2 - Permanently greased bearings

Under normal operating conditions, the service life (L10h) of the lubricant is 25,000 hours for a machine installed horizontally and for temperatures less than 25°C .

3.2.3 - Bearings with grease nipples

The bearings are lubricated in the factory

The end shields are fitted with bearings lubricated by Técalémit grease nipples.



The frequency of lubrication and quantity and quality of grease are indicated on the nameplates. Refer to these to ensure correct lubrication of the bearings.



Even in the event of prolonged storage or downtime, the interval between 2 greasing operations must never exceed 2 years.

LSRPM - PLSRPM

Synchronous permanent magnet motors

3.3 - Bearing maintenance

3.3.1 - Checking the bearings

As soon as you detect any of the following on the motor:

- abnormal noise or vibration
- abnormal temperature rise of the bearing when it is correctly greased, the state of the bearings must be checked.

Damaged bearings must be replaced as soon as possible to prevent worse damage to the motor and the equipment being driven.

When one bearing needs to be replaced, **the other bearing must also be replaced.**

The seals should be changed routinely when the bearings are changed.

The free bearing must allow the rotor shaft to expand (check its identification during dismantling).

3.3.2 - Reconditioning the bearings

Bearings without grease nipples

Dismantle the motor (see section 6.1); remove the old grease and clean the bearings and accessories with degreasing agent. Fill with new grease: the correct amount of new grease for the bearing is 50% of the free space.

Bearings with grease nipples

Always begin by cleaning the waste grease channel

When using the type of grease indicated on the nameplate, remove the covers and clean the grease nipple heads.

When using a different grease from that indicated on the nameplate, the motor must be dismantled and the bearings and accessories cleaned with degreasing agent (carefully clean the grease inlet and outlet channels) to remove the old grease before regreasing.

To ensure correct lubrication, fill the inner free spaces of the bearing retainers, flanges and grease channels and 30% of the bearing free space.

Then run the motor at low speed (< 500 min⁻¹) to distribute the grease.

Warning:

Too much grease causes the bearing to overheat (statistics show that more bearings are damaged through too much grease than too little grease).

Important note:

The new grease must be recently manufactured, of an equivalent performance level and must not contain any impurities (dust, water, etc.).

4 - PREVENTIVE MAINTENANCE

Please consult LEROY-SOMER who, in its continuous search for ways to help customers, has evaluated numerous methods of preventive maintenance.

The diagram and table below give the recommended equipment to use and the ideal positions to take measurements of all parameters which can affect the operation of the machine, such as eccentricity, vibration, state of the bearings, structural problems, electrical problems, etc.

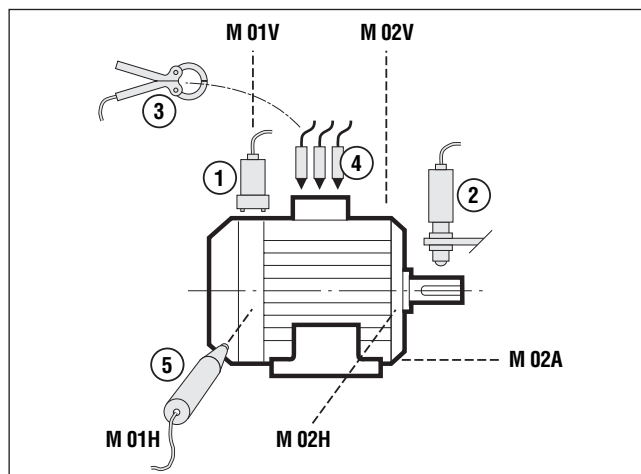

Detector	Measurement	Measurement points								
		M 01V	M 01H	M 02V	M 02H	M 02A	Shaft	E01	E02	E03
1 - Accelerometer	For measuring vibrations	●	●	●	●	●				
2 - Photo-electric cell	For measuring speed and phase (balancing)						●			
3 - Clamp ammeter	For measuring current (DC and 3-phase AC)							●	●	●
4 - Voltage probe	For measuring voltages							●	●	●
5 - Infra-red probe	For measuring temperature	●		●						

LSRPM - PLSRPM

Synchronous permanent magnet motors

5 - TROUBLESHOOTING GUIDE

Incident	Possible cause	Remedy
Abnormal noise	Originating in motor or machine being driven?	Uncouple the motor from the equipment being driven and test the motor on its own
Noisy motor	<p>The cause is mechanical if the noise persists after switching off the power supply, with the drive set to «freewheel» mode</p> <ul style="list-style-type: none"> - vibration - damaged bearings - mechanical friction: ventilation, coupling <p>The cause is electrical if the noise stops after switching off the power supply</p> <ul style="list-style-type: none"> - normal voltage and 3 phases balanced - abnormal voltage - phase imbalance <p>Other possible causes:</p> <ul style="list-style-type: none"> - incorrect settings - drive malfunction 	<ul style="list-style-type: none"> - check that the key conforms to the type of balancing (see section 2.3) - change the bearings - check - check the power supply at the motor terminals - check the drive settings - check the connection of the terminal block and the tightening of the terminals - check the power supply line - check the winding resistance - refer to the drive manual
Motor heats abnormally	<ul style="list-style-type: none"> - faulty ventilation - faulty supply voltage - terminal connection fault - overload - partial short-circuit - phase imbalance <p>Other possible causes:</p> <ul style="list-style-type: none"> - incorrect settings - drive malfunction 	<ul style="list-style-type: none"> - check the environment - clean the fan cover and the cooling fins - check that the fan is correctly mounted on the shaft - check - check - check the current consumption in relation to that indicated on the motor nameplate - check the electrical continuity of the windings and/or the installation - check the winding resistance - refer to the drive manual
Motor does not start	<p>at no load</p> <ul style="list-style-type: none"> - mechanical locking - broken power supply line - position feedback (drive message) - thermal protection <p>on load</p> <ul style="list-style-type: none"> - phase imbalance - drive - position feedback (drive message) - thermal protection 	<p>When switched off:</p> <ul style="list-style-type: none"> - check that rotation of the shaft is locked (Note: the rotor magnets generate resistance to rotation) - check the fuses, electrical protection, starting device - check the drive wiring and settings, operation of the position sensor - check <p>When switched off:</p> <ul style="list-style-type: none"> - check the direction of rotation (phase order) - check the resistance and continuity of the windings - check the electrical protection - check the settings and sizing (max. current that can be delivered by the drive) - check the drive wiring and settings, operation of the position sensor - check

LSRPM - PLSRPM

Synchronous permanent magnet motors

6 - CORRECTIVE MAINTENANCE: GENERAL



First switch off and lock the power supply.

- open the terminal box, mark the wires and their positions,
 - disconnect the power supply wires,
 - uncouple the motor from the equipment being driven.
- Always use an extractor to remove any devices mounted on the motor shaft extension.

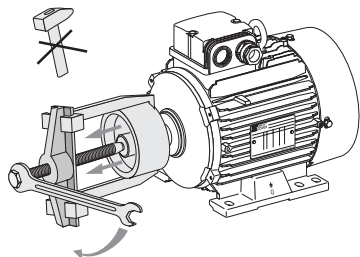

6.1 - Dismantling the motor

Refer to the detailed instructions for the relevant motor range (see following pages).

It is advisable to mark the shields in relation to the stator and the direction in which the fan is mounted on the rotor.

6.2 - Checks before reassembly

Stator :

- remove any dust from the stator:
- if the winding needs to be cleaned, a suitable liquid must be used: dielectric and inert on the insulating components and the external finish.
- check the insulation (see section 2.1) and if necessary, dry it in an oven.
 - clean the spigots thoroughly, and remove all traces of impact on the mating surfaces if necessary.

Rotor:

- clean and check the bearing running surfaces. If they are damaged, renew the running surfaces or change the rotor.
- check the condition of the threads, keys and their housings.

End shields:

- clean off any traces of dirt (old grease, accumulated dust, etc).
- clean the bearing housings and the spigot.
- if necessary, apply anti-flash varnish inside the end shields.
- carefully clean the bearing retainers and the grease valves (if these are fitted on the motor).

6.3 - Mounting the bearings on the shaft

This operation is extremely important, as the slightest indentation of a ball on the bearing tracks would cause noise and vibration.

Lightly lubricate the running surfaces of the shaft.

There are a number of ways of mounting the bearings correctly:

- cold state: The bearings must be mounted without any impact, using a spanner (do not use a hammer). The force applied must not be transferred to the bearing track. You should therefore use the internal cage for support (taking care not to press on the seal shield for sealed bearings).
- hot state: Heat the bearing to between 80 and 100°C: in a dryer, an oven or on a heating plate.

(A blowtorch or an oil bath must never be used).

After dismantling and reassembling a bearing, all the spaces between the seals and labyrinth seals must be filled with grease in order to prevent the entry of dust and the rusting of machined parts.

See detailed instructions for the relevant motor ranges in the following pages.

6.4 - Reassembling the motor

Care must be taken to ensure that the stator is replaced in its original position, so that the stack of laminations is centred correctly (generally with the terminal box facing forward) and the water drain holes are positioned correctly if they are on the housing.

Tightening the tie rods

These must be tightened diagonally, to the torque indicated (see below).

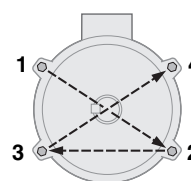

Tie rod tightening torque

Type	Rod/screw Ø	Tightening torque N. m \pm 5 %
90	M5	4
100	M5 ou M6	4
132	M7	10
160	M8	18
200		
225 ST/MR	M10	25
225 MG		
250		
280	M12	44
315		

6.5 - Reassembling the terminal box

Reconnect all the power supply wires in accordance with the diagram or markings made before dismantling.

To ensure the box is properly sealed: check that the cable glands on the box and the cable(s) have been retightened, and ensure that the seal has been correctly positioned before closing. For terminal boxes equipped with a horn (part no. 89 on the exploded views) or/and a cable gland support plate, ensure that the seal has been correctly positioned before closing. Check that the terminal box components are tightened correctly.

Note: It is advisable to test the motor at no load

- If necessary, repaint the motor.
- Mount the transmission device on the motor shaft extension and reinstall the motor on the machine to be driven.

6.6 - Checking the Hall effect sensors

- Rotate the motor (if necessary uncouple).
- Using a voltmeter, check that the voltages between the 0 V and \bar{U} , \bar{V} and \bar{W} and U, V, W change correctly from 0 V to approximately 13.5 V when the shaft rotates.
- \triangle Contact between wires



For any given position of the motor shaft, the voltages on the 3 phases must not be simultaneously either 0 V or 13.5 V.

For replacement of the sensors, refer to the section on dismantling/reassembly.

LSRPM - PLSRPM

Synchronous permanent magnet motors

7 - POSITION OF LIFTING RINGS

⚠ Position of the lifting rings for lifting the motor only (not connected to the machine).

Labour regulations stipulate that all loads over 25 kg must be fitted with lifting devices to facilitate handling. The positions of the lifting rings and the minimum dimensions of the loading bars are given below in order to help with preparation for handling the motors. If these precautions are not followed, there is a risk of warping or crushing some equipment such as the terminal box, cover or drip cover.

⚠ Motors intended for use in the vertical position may be delivered on a pallet in the horizontal position. When the motor is pivoted, the shaft must under no circumstances be allowed to touch the ground, as the bearings may be irreparably damaged. Moreover, additional special precautions must be taken, as the integral motor lifting rings are not designed for pivoting the motor.

• Vertical position

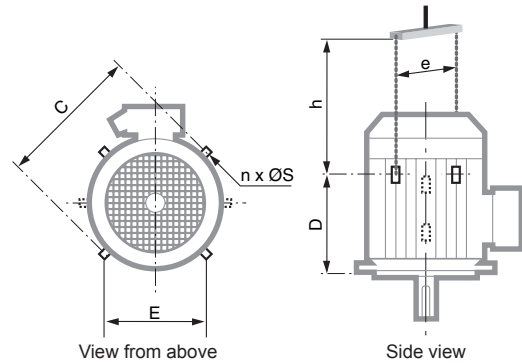

Type	Vertical position (mm)						
	C	E	D	n	ØS	e mini *	h mini
160	320	200	230	2	14	320	350
200	440	300	340	2	25	410	450
225	460	360	370	2	25	410	450
250	500	360	500	4	45	540	350
280 SC/SD/MD	500	360	500	4	45	590	550
280 MK	590	360	585	4	30	590	550
315	590	-	590	2	30	630	550

* If the motor is fitted with a drip cover, allow an additional 50 to 100 mm to avoid damaging it when the load is swung.

• Horizontal position

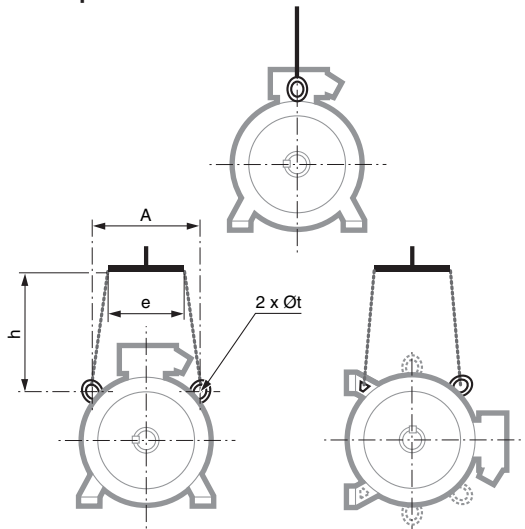

Type	Horizontal position (mm)			
	A	e mini	h mini	Øt
132	160	200	150	9
160	200	160	110	14
200	260	260	165	25
225	300	260	150	25
250	400	380	200	45
280 SC/SD/MD	400	380	500	45
280 MK	400	380	500	30
315	400	380	500	30

LSRPM - PLSRPM

Synchronous permanent magnet motors

8 - SPARE PARTS

When ordering spare parts, you must indicate the complete motor type, its serial number and the information given on the nameplate (see section 1).

Part numbers can be found on the exploded views and their descriptions in the parts list (section 9).

In the case of flange mounted motors, indicate the type of flange and its dimensions (see below).

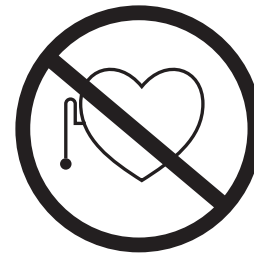
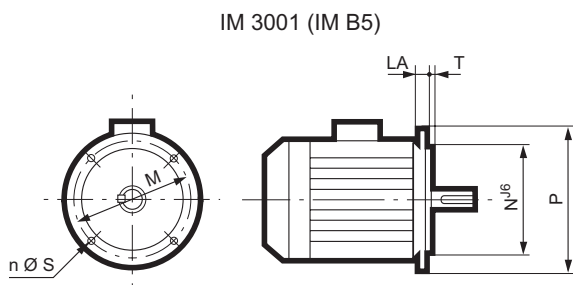

Our extensive network of service centres can dispatch the necessary parts without delay.

To ensure that our motors operate correctly and safely, we recommend the use of original manufacturer spare parts.

In the event of failure to comply with this advice, the manufacturer cannot be held responsible for any damage.

Assembly or maintenance of the rotor must not be carried out by people with pacemakers or any other implanted medical devices.

The motor rotor contains a powerful magnetic field. When the rotor is separated from the motor, its field may affect pacemakers or disturb digital devices such as watches, mobile phones, etc.

Installation, servicing and maintenance must only be carried out by qualified personnel.

Failure to follow the instructions in this document, or to apply them correctly, releases the manufacturer from liability.

The product is covered by the warranty during the guarantee period as long as any partial or total dismantling has only been performed with the assistance of LEROY-SOMER (or its approval).

LSRPM - PLSRPM

Synchronous permanent magnet motors

9 - DISMANTLING - REASSEMBLY

9.1 - LSRPM 90 L motors

9.1.1 - Dismantling

- Remove the screws (27) and then take off the cover (13).
- Remove the screw, then pull out the fan (7) with its bushing (224).
- **If encoder already present:** remove the lock nuts fastening the encoder to the spacers (296) then unscrew the encoder (159) from the NDE shaft extension.
- Remove the encoder connector lock nut (187).
- Take out the key (21) and remove the drive end and non drive end seals (39 and 54).
- Unscrew the tie rods (14) then remove them.
- Using a bronze drift, remove the NDE shield (6) and recover the preloading washer (59), then disengage the DE shield from the housing bore.
- **If Hall effect sensor already present:** disconnect the Hall effect sensor (93) (Caution: cable should be pulled out).
- Take care not to remove the rotor from the stator. If absolutely necessary, place the motor in a vertical position and clamp the stator so as to overcome the magnetic force, as described in the procedure in the appendix.
- Using a hoist, remove the rotor from the stator, taking care not to touch the winding.
- It is possible to remove the rotor horizontally by knocking the NDE shaft extension hard with a plastic mallet.
- Remove the circlip (38).
- Remove the DE shield.
- Take out the bearings (30) and (50) using a bearing remover, while protecting the end of the shaft extension with a washer. Avoid knocking the running surfaces of the shaft.

9.1.2 - Reassembly

- See section 6.2 before reassembly.
- Slide the circlip (38) onto the front part of the shaft.
- Mount the new bearings on the shaft (see section 6.3 on mounting bearings).
- Place the end shield (5) in position and fix it with the circlip (38).
- Screw in a shackle, place the motor in a vertical position and clamp the stator as described in the procedure in the appendix.
- Using a hoist, slowly lower the rotor into the stator, taking care not to touch the winding.

⚠ Warning: the rotor exerts a very strong magnetic force. Since there is a risk of trapping your fingers between the DE shield and the housing spigot, it is advisable to hold the housing with one hand and the rotor with the other hand by the DE shaft extension.

- **If Hall effect sensor already present:** connect the Hall effect sensor (pass the cable fully back through).
- Position the preloading washer (59) with a small amount of grease in the back of the bearing cage of the NDE shield (6), then remount the NDE shield (6), positioning it on the housing.
- Fit a new seal (39) with the spring facing outwards.
- Place the tie rods (14) in position and tighten the nuts diagonally to the recommended torque (see section 6.4).
- Mount the shield seals with grease (54 at the non drive end) (39 at the drive end).
- **If encoder already present:** reassemble the encoder (procedure in the appendix).
- Mount the fan (7) using a drift to bed it into position.

- Using a key in the handle, check that the rotor turns, then remove the handle. Check also that there is no axial play if there is a locked end shield.
- Replace the cover (13) and fix it with the screws (27).
- Replace the key (21).

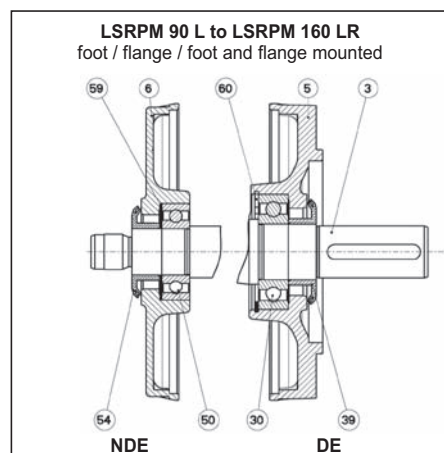
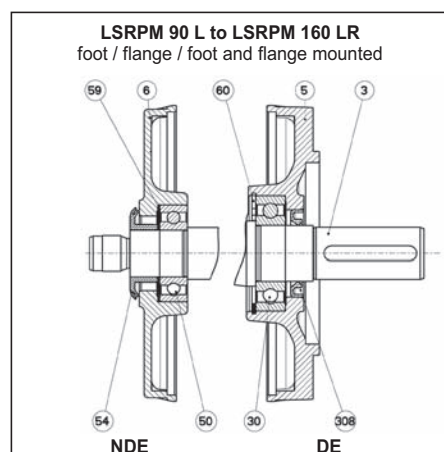
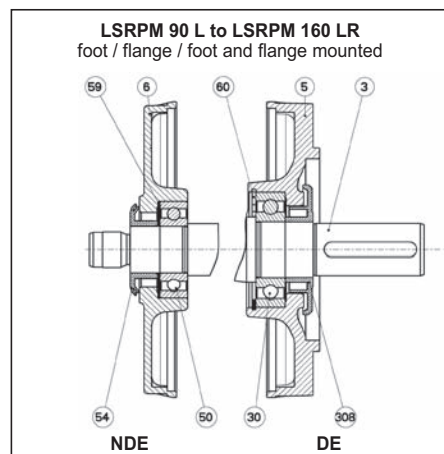

LSRPM - PLSRPM

Synchronous permanent magnet motors

LSRPM 90 L

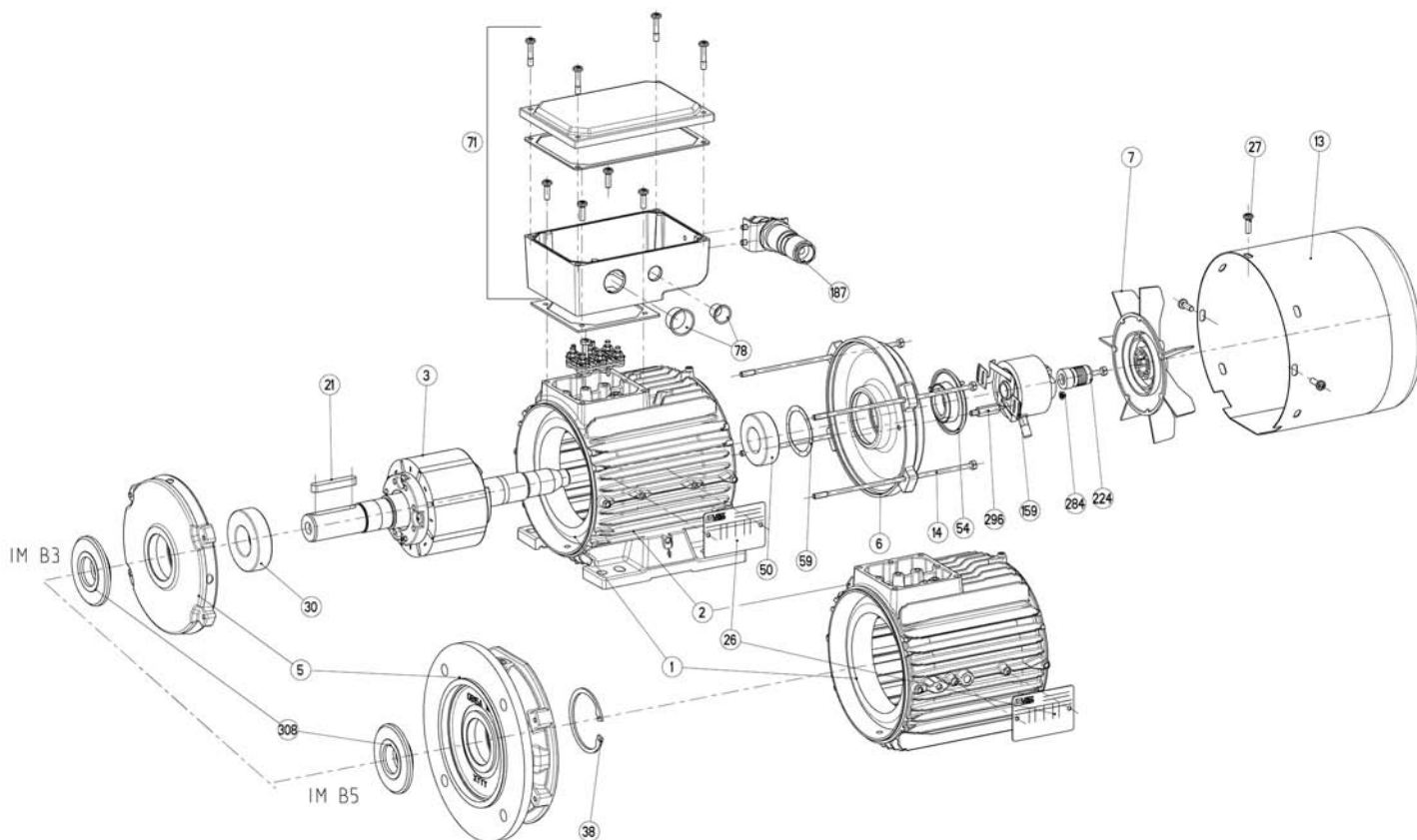

Nbr	Description	Nbr	Description	Nbr	Description
1	Wound stator	21	Key	71	Terminal box
2	Housing	26	Nameplate	78	Plug
3	Rotor	27	Cover fixing screw	159	Encoder
5	DE shield	30	DE bearing	187	Encoder connector
6	NDE shield	38	Drive end bearing circlip	224	Fan bushing
7	Fan	50	NDE bearing	284	Nut
13	Fan cover	54	NDE seal	296	Spacer
14	Tie rods	59	Preloading (wavy) washer	308	Labyrinth seal

LSRPM - PLSRPM

Synchronous permanent magnet motors

9.2 - LSRPM 100 L motors

9.2.1 - Dismantling

- Remove the screws (27) and then take off the cover (13).
- Remove the screw, then pull out the fan (7) with its bushing (224).
- **If encoder already present:** remove the lock nuts fastening the encoder to the spacers (296) then unscrew the encoder (159) from the NDE shaft extension.
- Remove the encoder connector lock nut (187).
- Take out the key (21) and remove the drive end and non drive end seals (39 and 54).
- Unscrew the tie rods (14) then remove them.
- Using a bronze drift, remove the NDE shield (6) and recover the preloading washer (59), then disengage the DE shield from the housing bore.
- **If Hall effect sensor already present:** disconnect the Hall effect sensor (93) (Caution: cable should be pulled out).
- Take care not to remove the rotor from the stator. If absolutely necessary, place the motor in a vertical position and clamp the stator so as to overcome the magnetic force, as described in the procedure in the appendix.
- Using a hoist, remove the rotor from the stator, taking care not to touch the winding.
- It is possible to remove the rotor horizontally by knocking the NDE shaft extension hard with a plastic mallet.
- Remove the circlip (38).
- Remove the DE shield.
- Take out the bearings (30) and (50) using a bearing remover, while protecting the end of the shaft extension with a washer. Avoid knocking the running surfaces of the shaft.

9.2.2 - Reassembly

- See section 6.2 before reassembly.
- Slide the circlip (38) onto the front part of the shaft.
- Mount the new bearings on the shaft (see section 6.3 on mounting bearings).
- Place the end shield (5) in position and fix it with the circlip (38).
- Screw in a shackle, place the motor in a vertical position and clamp the stator as described in the procedure in the appendix.
- Using a hoist, slowly lower the rotor into the stator, taking care not to touch the winding.

⚠ Warning: the rotor exerts a very strong magnetic force. Since there is a risk of trapping your fingers between the DE shield and the housing spigot, it is advisable to hold the housing with one hand and the rotor with the other hand by the DE shaft extension.

- **If Hall effect sensor already present:** connect the Hall effect sensor (pass the cable fully back through).
- Position the preloading washer (59) with a small amount of grease in the back of the bearing cage of the NDE shield (6), then remount the NDE shield (6), positioning it on the housing.
- Fit a new seal (39) with the spring facing outwards.
- Place the tie rods (14) in position and tighten the nuts diagonally to the recommended torque (see section 6.4).
- Mount the shield seals with grease (54 at the non drive end) (39 at the drive end).
- **If encoder already present:** reassemble the encoder (procedure in the appendix).
- Mount the fan (7) using a drift to bed it into position.

- Using a key in the handle, check that the rotor turns, then remove the handle. Check also that there is no axial play if there is a locked end shield.
- Replace the cover (13) and fix it with the screws (27).
- Replace the key (21).

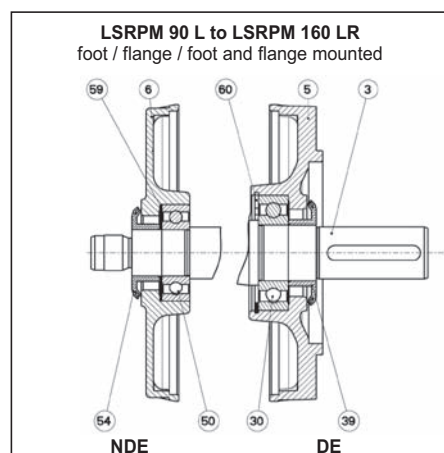
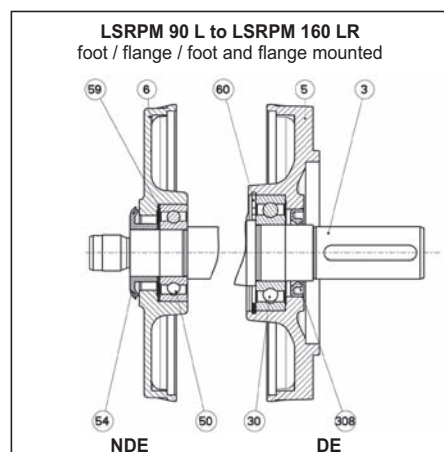
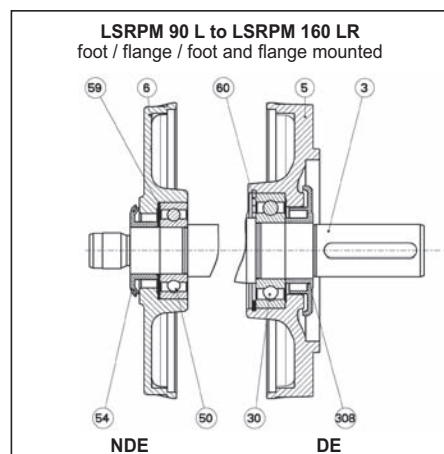

LSRPM - PLSRPM

Synchronous permanent magnet motors

LSRPM 100 L

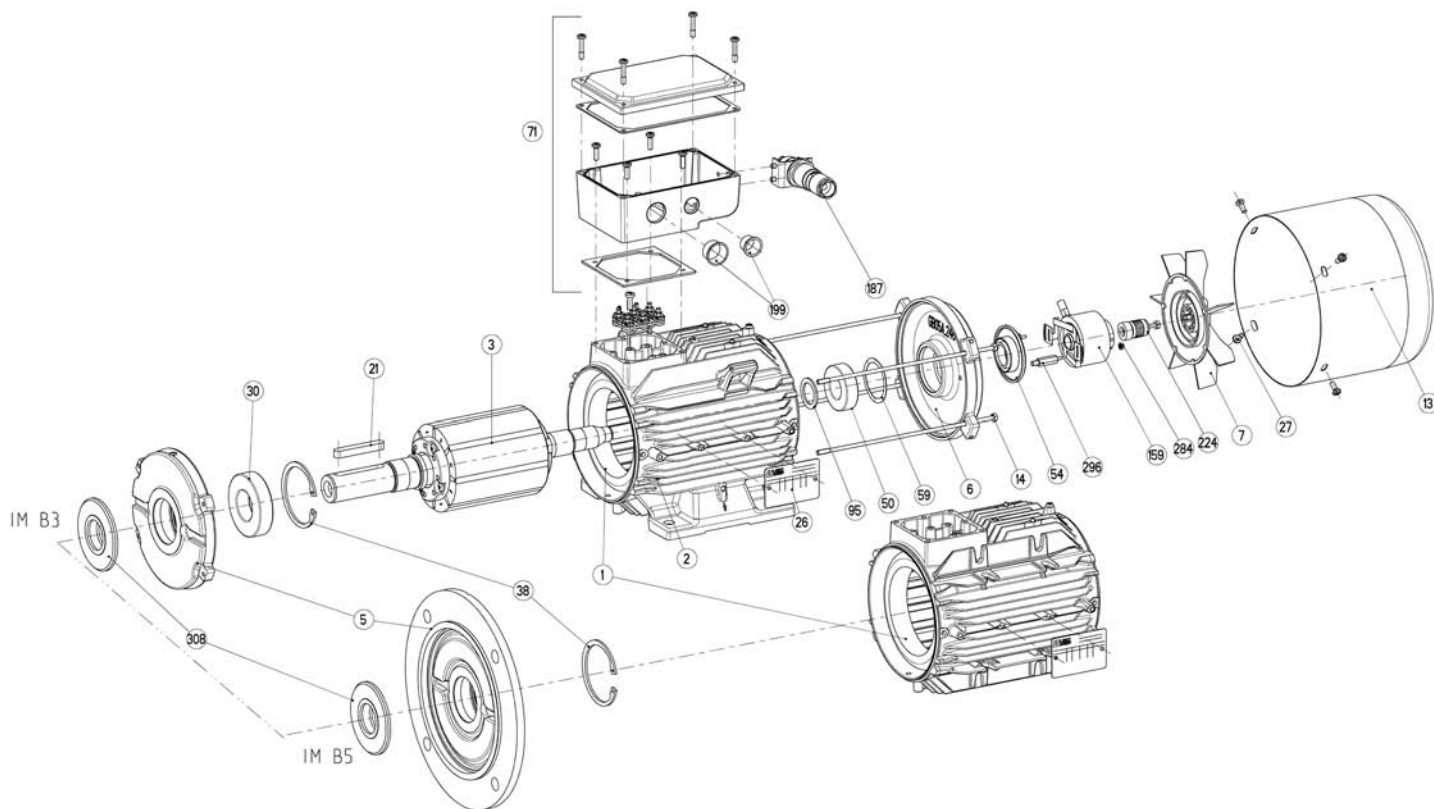

Nbr	Description	Nbr	Description	Nbr	Description
1	Wound stator	26	Nameplate	159	Encoder
2	Housing	27	Cover fixing screw	187	Encoder connector
3	Rotor	30	DE bearing	199	Plug
5	DE shield	38	Drive end bearing circlip	224	Fan bushing
6	NDE shield	50	NDE bearing	284	Nut
7	Fan	54	NDE seal	296	Spacer
13	Fan cover	59	Preloading (wavy) washer	308	Labyrinth seal
14	Tie rods	71	Terminal box		
21	Key	95	Bearing cable gland washer		

LSRPM - PLSRPM

Synchronous permanent magnet motors

9.3 - LSRPM 132 M motors

9.3.1 - Dismantling

- Remove the screws (27) and then take off the cover (13).
- Remove the screw, then pull out the fan (7) with its bushing (224).
- **If encoder already present:** remove the lock nuts fastening the encoder to the spacers (296) then unscrew the encoder (159) from the NDE shaft extension.
- Remove the encoder connector lock nut (187).
- Take out the key (21) and remove the drive end and non drive end seals (39 and 54).
- Unscrew the tie rods (14) then remove them.
- Using a bronze drift, remove the NDE shield (6) and recover the preloading washer (59), then disengage the DE shield from the housing bore.
- **If Hall effect sensor already present:** disconnect the Hall effect sensor (93) (Caution: cable should be pulled out).
- Take care not to remove the rotor from the stator. If absolutely necessary, place the motor in a vertical position and clamp the stator so as to overcome the magnetic force, as described in the procedure in the appendix.
- Remove the rotor from the stator using a hoist, taking care not to touch the winding.
- Remove the circlip (38).
- Remove the DE shield.
- Take out the bearings (30) and (50) using a bearing remover, while protecting the end of the shaft extension with a washer. Avoid knocking the running surfaces of the shaft.

9.3.2 - Reassembly

- See section 6.2 before reassembly.
- Slide the circlip (38) onto the front part of the shaft.
- Mount the new bearings on the shaft (see section 6.3 on mounting bearings).
- Place the end shield (5) in position and fix it with the circlip (38).
- Screw in a shackle, place the motor in a vertical position and clamp the stator as described in the procedure in the appendix.
- Using a hoist, slowly lower the rotor into the stator, taking care not to touch the winding.
- ⚠ **Warning:** the rotor exerts a very strong magnetic force. Since there is a risk of trapping your fingers between the DE shield and the housing spigot, it is advisable to hold the housing with one hand and the rotor with the other hand by the DE shaft extension.
- Place the motor in a horizontal position.
- **If Hall effect sensor already present:** connect the Hall effect sensor (pass the cable fully back through).
- Position the preloading washer (59) with a small amount of grease in the back of the bearing cage of the NDE shield (6), then remount the NDE shield (6), positioning it on the housing.
- Fit a new seal (39) with the spring facing outwards.
- Place the tie rods (14) in position and tighten the nuts diagonally to the recommended torque (see section 6.4).
- Mount the shield seals with grease (54 at the non drive end) (39 at the drive end).
- **If encoder already present:** reassemble the encoder (procedure in the appendix).
- Mount the fan (7) using a drift to bed it into position.
- Using a key in the handle, check that the rotor turns, then remove the handle. Check also that there is no axial play if there is a locked end shield.
- Replace the cover (13) and fix it with the screws (27).
- Replace the key (21).

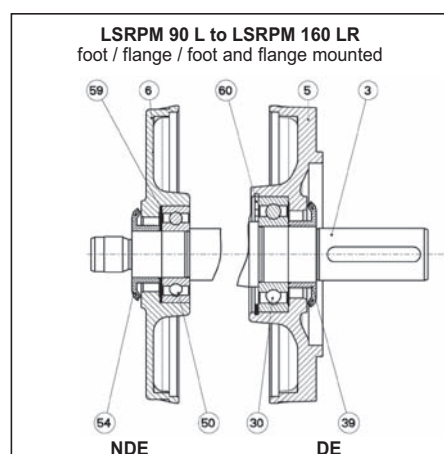
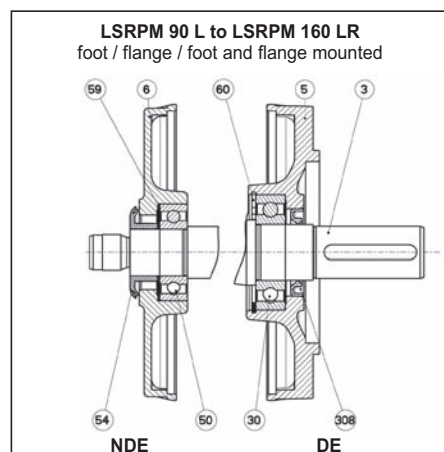
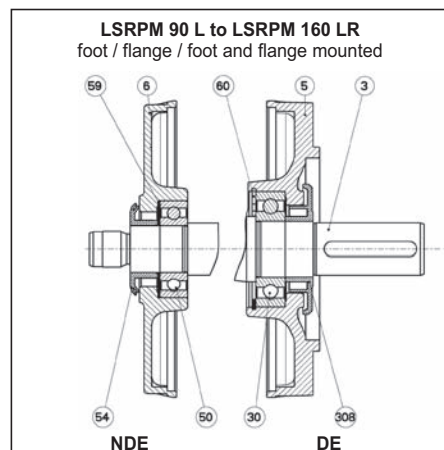

LSRPM - PLSRPM

Synchronous permanent magnet motors

LSRPM 132 M

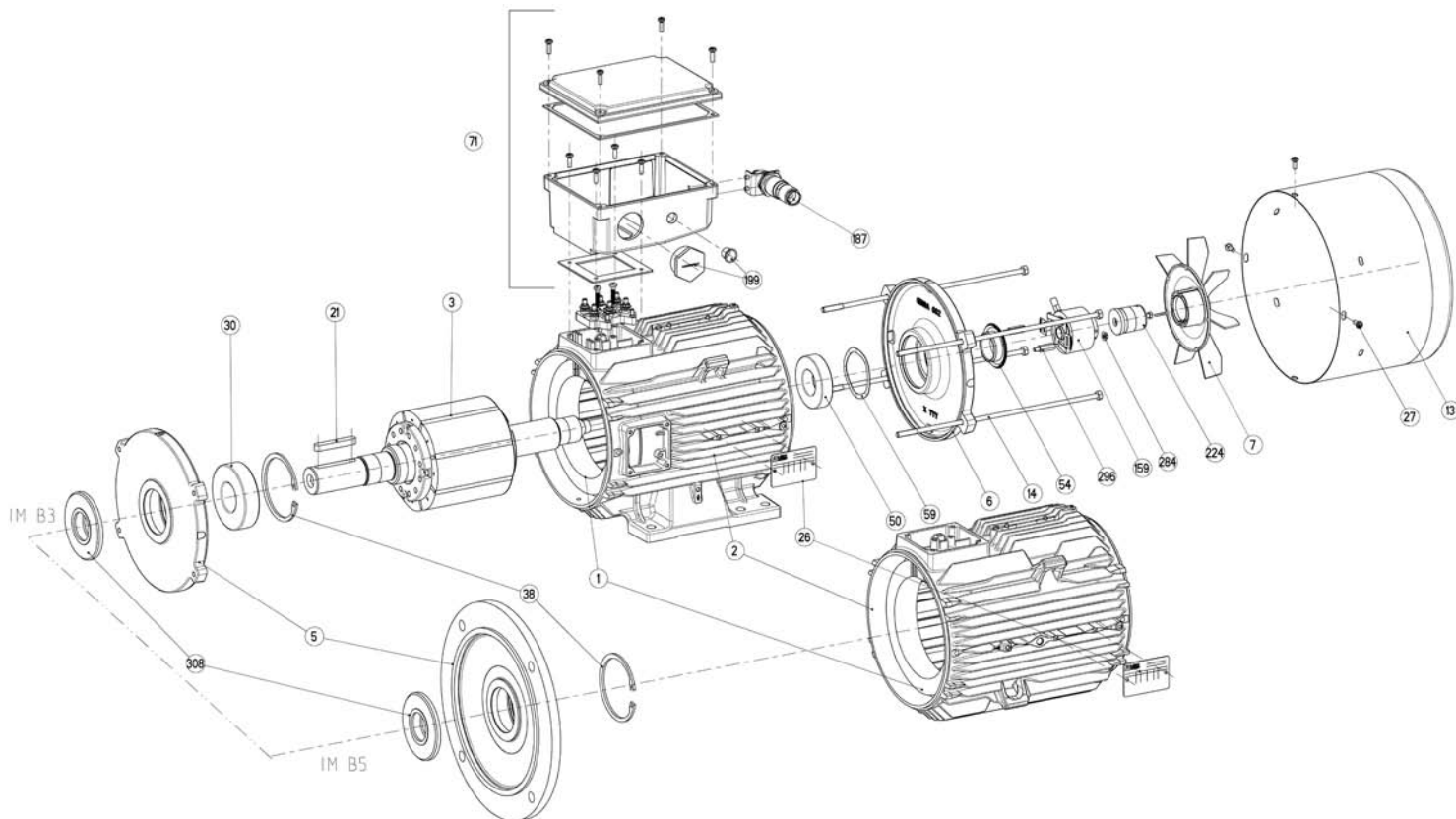

Nbr	Description	Nbr	Description	Nbr	Description
1	Wound stator	21	Key	71	Terminal box
2	Housing	26	Nameplate	159	Encoder
3	Rotor	27	Cover fixing screw	187	Encoder connector
5	DE shield	30	DE bearing	199	Plug
6	NDE shield	38	Drive end bearing circlip	224	Fan bushing
7	Fan	50	NDE bearing	284	Nut
13	Fan cover	54	NDE seal	296	Spacer
14	Tie rods	59	Preloading (wavy) washer	308	Labyrinth seal

LSRPM - PLSRPM

Synchronous permanent magnet motors

9.4 - LSRPM 160 MR/LR motors

9.4.1 - Dismantling

- Remove the screws (27) and then take off the cover (13).
- Remove the screw, then pull out the fan (7) with its bushing (224).
- **If encoder already present:** remove the lock nuts fastening the encoder to the spacers (296) then unscrew the encoder (159) from the NDE shaft extension.
- Remove the encoder connector lock nut (187).
- Take out the key (21) and remove the drive end and non drive end seals (39 and 54).
- Unscrew the tie rods (14) then remove them.
- Using a bronze drift, remove the NDE shield (6) and recover the preloading washer (59), then disengage the DE shield from the housing bore.
- **If Hall effect sensor already present:** disconnect the Hall effect sensor (93) (Caution: cable should be pulled out).
- Take care not to remove the rotor from the stator. If absolutely necessary, place the motor in a vertical position and clamp the stator so as to overcome the magnetic force, as described in the procedure in the appendix.
- Remove the rotor from the stator using a hoist, taking care not to touch the winding.
- Remove the circlip (38).
- Remove the DE shield.
- Take out the bearings (30) and (50) using a bearing remover, while protecting the end of the shaft extension with a washer. Avoid knocking the running surfaces of the shaft.

9.4.2 - Reassembly

- See section 6.2 before reassembly.
- Slide the circlip (38) onto the front part of the shaft.
- Mount the new bearings on the shaft (see section 6.3 on mounting bearings).
- Place the end shield (5) in position and fix it with the circlip (38).
- Screw in a shackle, place the motor in a vertical position and clamp the stator as described in the procedure in the appendix.
- Using a hoist, slowly lower the rotor into the stator, taking care not to touch the winding.
- ⚠ **Warning:** the rotor exerts a very strong magnetic force. Since there is a risk of trapping your fingers between the DE shield and the housing spigot, it is advisable to hold the housing with one hand and the rotor with the other hand by the DE shaft extension.
- Place the motor in a horizontal position.
- **If Hall effect sensor already present:** connect the Hall effect sensor (pass the cable fully back through).
- Position the preloading washer (59) with a small amount of grease in the back of the bearing cage of the NDE shield (6), then remount the NDE shield (6), positioning it on the housing.
- Fit a new seal (39) with the spring facing outwards.
- Place the tie rods (14) in position and tighten the nuts diagonally to the recommended torque (see section 6.4).
- Mount the shield seals with grease (54 at the non drive end) (39 at the drive end).
- **If encoder already present:** reassemble the encoder (procedure in the appendix).
- Mount the fan (7) using a drift to bed it into position.
- Using a key in the handle, check that the rotor turns, then remove the handle. Check also that there is no axial play if there is a locked end shield.
- Replace the cover (13) and fix it with the screws (27).
- Replace the key (21).

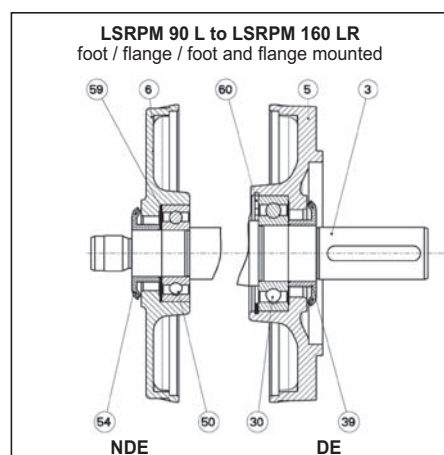
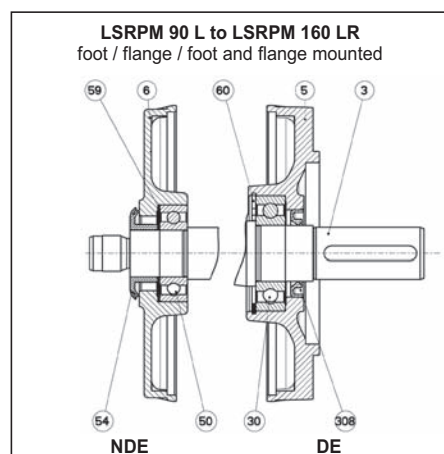
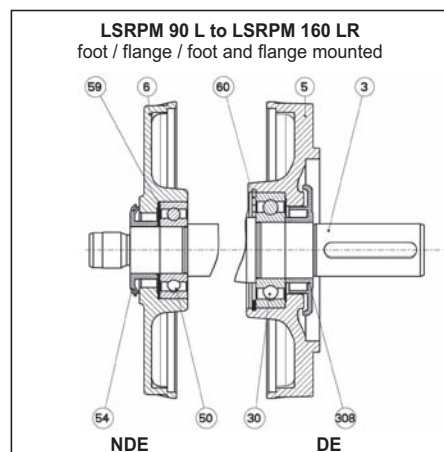

LSRPM - PLSRPM

Synchronous permanent magnet motors

LSRPM 160 MR/LR

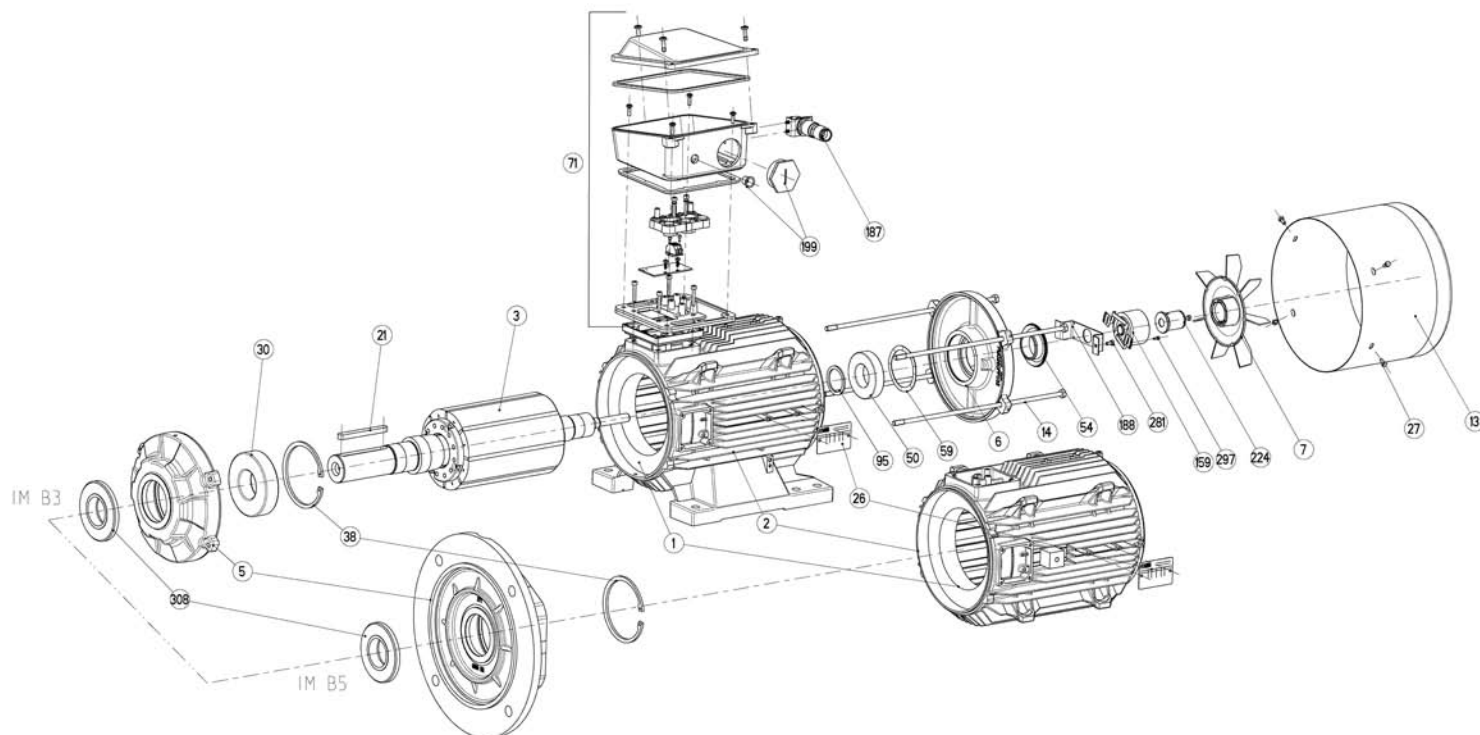

Nbr	Description	Nbr	Description	Nbr	Description
1	Wound stator	26	Nameplate	95	Bearing cable gland washer
2	Housing	27	Cover fixing screw	159	Encoder
3	Rotor	30	DE bearing	187	Encoder connector
5	DE shield	38	Drive end bearing circlip	188	Encoder support
6	NDE shield	39	Drive end seal	199	Plug
7	Fan	50	NDE bearing	224	Fan bushing
13	Fan cover	54	NDE seal	281	Screw
14	Tie rods	59	Preloading (wavy) washer	297	Fixing screw
21	Key	71	Terminal box	308	Labyrinth seal

LSRPM - PLSRPM

Synchronous permanent magnet motors

9.5 - LSRPM 200, LSRPM 225, LSRPM 250, LSRPM 280 SC/SD/MD motors

9.5.1 - Dismantling

- Remove the screws (27) and then take off the cover (13).
- Pull out the fan (7) using a hub remover or 2 levers diametrically opposite one another, using the shield (6) for support.
- Take out the key (21) and remove the seals (39 and 54 for foot mounted motors) (54 for flange mounted motors).
- Unscrew the tie rods (14) then remove them.
- Unscrew the inner bearing retainer (33) fixing screws (40) when using a flange mounted motor or if the drive end bearing is locked.
- Using a bronze drift, remove the shields (5 and 6) by tapping gently on the shield bosses. Take out the preloading washer (59).
- **If Hall effect sensor already present:** disconnect the Hall effect sensor (93) (Caution: cable should be pulled out).
- Take care not to remove the rotor from the stator. This is not necessary when extracting bearings. If absolutely necessary, screw in a handle, place the motor in a vertical position and then clamp the stator as described in the procedure in the appendix.
- Remove the rotor from the stator using a hoist, taking care not to touch the winding.
- Take out the bearings (30) and (50) using a bearing remover, while protecting the end of the shaft extension with a washer. Avoid knocking the running surfaces of the shaft.

9.5.2 - Reassembly

- See section 6.2 before reassembly.
- If necessary, insert the inner bearing retainer (33) at the rotor drive end, then mount new bearings on the shaft, see section 6.3 on mounting bearings.
- Fill with new grease: the correct amount of new grease for the bearing is 50% of the free space.
- Fit the circlip (38) if necessary.
- Screw in a shackle, place the motor in a vertical position and clamp the stator as described in the procedure in the appendix.
- Using a hoist, slowly lower the rotor into the stator, taking care not to touch the winding.

⚠ Warning: the rotor exerts a very strong magnetic force.

- Place the motor in a horizontal position.
- **If Hall effect sensor already present:** connect the Hall effect sensor (pass the cable fully back through).
- Position the preloading washer (59) with a small amount of grease in the back of the bearing cage of the NDE shield (6), then remount the NDE shield (6), positioning it on the housing.
- If there is a bearing retainer (33), screw a rod with the same thread diameter as the screws (40) into one of the tapped holes on the bearing retainer to maintain its angular position when remounting the DE shield (5).
- When there is a flange, fit a new seal (39) with the spring facing outwards.
- Remount the shield (5) taking care to allow for the positioning of a bearing retainer if used.
- Place the tie rods (14) in position and tighten the nuts diagonally to the recommended torque (see section 6.4).
- If necessary, fix the bearing retainer (33) with the screws (40).
- Mount the shield seals with grease: (54 at the non drive end) (39 at the drive end for foot mounted motors).
- Mount the fan (7) using a drift to bed it into position.
- Using a key in the handle, check that the rotor turns, then remove the handle. Check also that there is no axial play if there is a locked end shield.
- Replace the cover (13) and fix it with the screws (27).
- Replace the key (21).

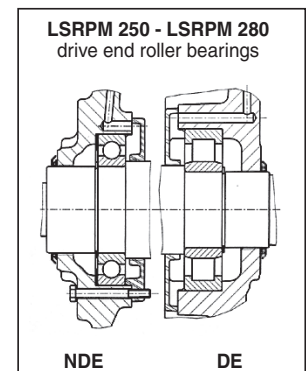
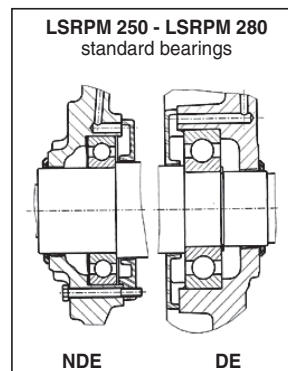
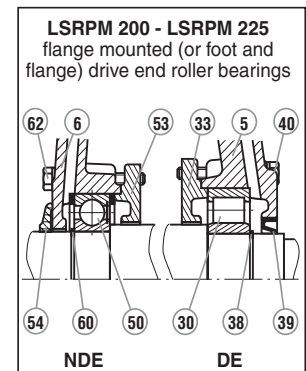
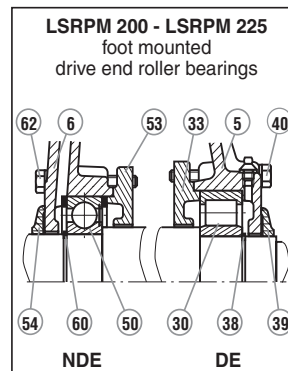
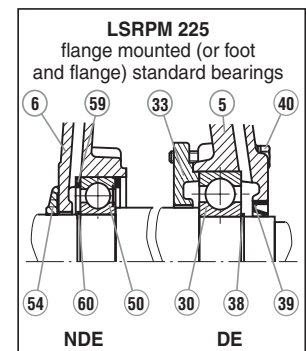
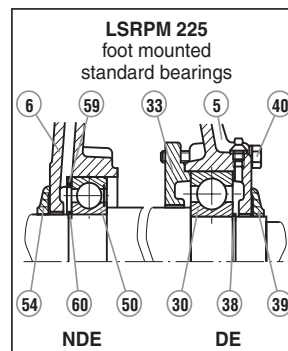
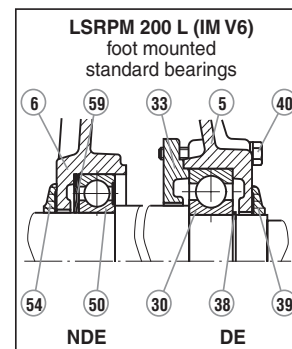
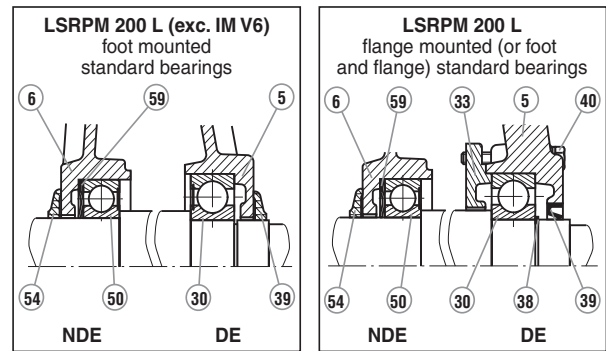

LSRPM - PLSRPM

Synchronous permanent magnet motors

LSRPM 200, LSRPM 225, LSRPM 250, LSRPM 280 SC/SD/MD

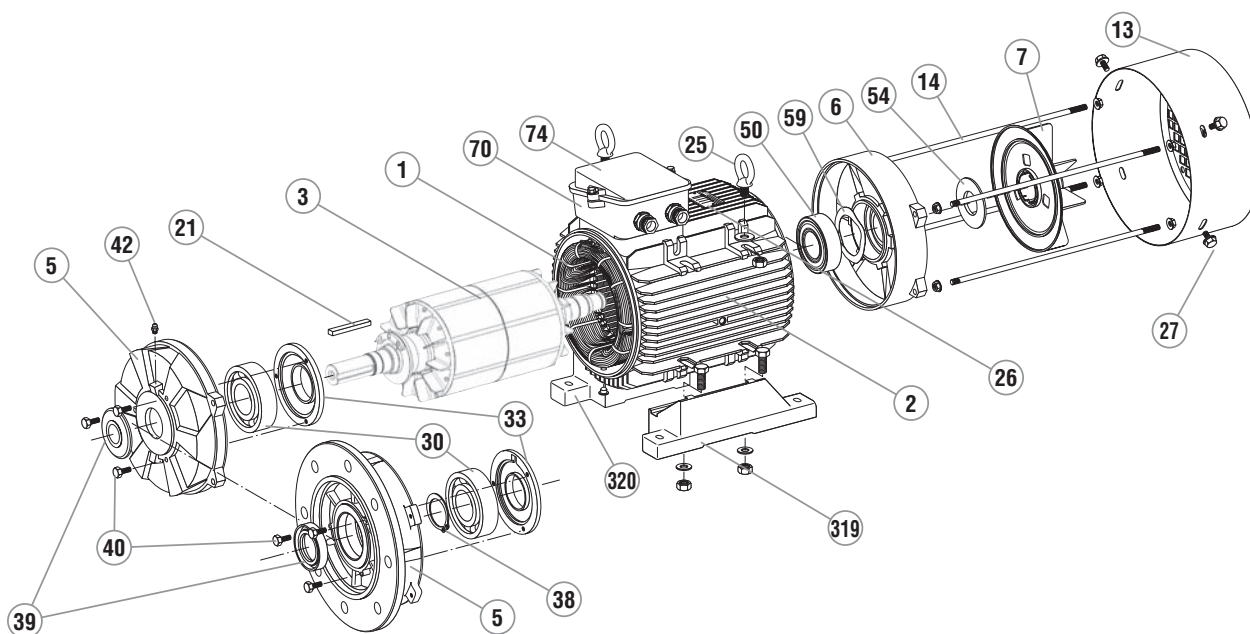

Nbr	Description	Nbr	Description	Nbr	Description
1	Wound stator	25	Lifting ring	50	NDE bearing
2	Housing	26	Nameplate	54	NDE seal
3	Rotor	27	Cover fixing screw	59	Preloading (wavy) washer
5	DE shield	30	DE bearing	70	Terminal box
6	NDE shield	33	Inner DE bearing retainer	74	Terminal box cover
7	Fan	38	Drive end bearing circlip	319	Right foot
13	Fan cover	39	Drive end seal	320	Left foot
14	Tie rods	40	Cover fixing screw		
21	Key	42	Grease nipples (eoptional for LS 180 L, LS 200)		

LSRPM - PLSRPM

Synchronous permanent magnet motors

9.6 - LSRPM 280 MK1, LSRPM 315 motors

9.6.1 - Dismantling

- Remove the screws (27), the grease nipple (42) and its extension, then take off the cover (13).
- Pull out the fan (7) using a hub remover or 2 levers diametrically opposite one another, using the shield (6) for support. For an aluminium fan, heat the hub to approximately 100°C before removing it.
- Take out the key (21).
- Unscrew the tie rods (14) then remove them.
- Unscrew the DE inner bearing retainer (33) fixing screws (40) and the fixing screws (62) on the NDE bearing retainers (32) and (52), and remove the bearing retainers.
- Unscrew the «Hc» screws on the mobile valves (35 and 56) then unscrew the valves using a hook spanner or a conical bronze drift. Unscrew the valves by hand and remove them. The valves hold the seals (39 and 54) in place.
- Remove the fixed valves (34 and 35) from the bearing housings.
- Using a bronze drift, remove the shields (5 and 6) by tapping gently on the shield bosses.
- Check that the diameter of the bearing retainer (53) is smaller than that of the stator, otherwise remove the bearing (50) in accordance with the following instructions.
- Disconnect the Hall effect sensor.
- Take care not to remove the rotor from the stator. If absolutely necessary, place the motor in a vertical position then screw a handle into the shaft extension hole.

 Warning: metal environment.

- Clamp the stator to overcome the magnetic force and remove the rotor from the stator using a hoist, taking care not to touch the winding.
- Take out the bearings (30) and (50) using a bearing remover, while protecting the end of the shaft extension with a washer. Avoid knocking the running surfaces of the shaft.
- The bearings are removed either separately or with the bearing retainers (33 and 53). To avoid damaging the bearing retainers, heat the outer bearing ring (the bearing should be discarded).
- Recover the preloading washer or springs (59) from the bearing retainer (53).

9.6.2 - Reassembly

- See section 6.2 before reassembly.
- Insert the rotor drive end inner bearing retainer (33) and the non drive end inner bearing retainer (53), not forgetting to insert the preloading springs (59).
- Fill with new grease: the correct amount of new grease for the bearing is 50% of the free space.
- Mount the new bearings (30 and 50) on the shaft, see section 6.3 on mounting bearings.
- Place the stator in a vertical position. Using a hoist, slowly lower the rotor into the stator, taking care not to touch the winding.

 Warning: the rotor exerts a very strong magnetic force.

- Place the motor in a horizontal position.
- Connect the Hall effect sensor.
- Screw a rod with the same thread diameter as the screws (40) and (62) into one of the tapped holes on the bearing retainers (33) and (53) to maintain the position of the grease nipple when refitting the shields (5 and 6).

- Check that the preloading springs are properly installed.
- Fit the NDE shield (6), positioning it on the stator, then mount the fixed valve (55) in the shield bearing housing.
- Mount the mobile valve (56) by either screwing it or locking it, having carefully installed the seal (54) on the valve.
- Mount the outer bearing retainer (52) with the bearing retainer locking screws (62), making sure that the grease drain hole is at the bottom.
- Mount the shield (5) at the drive end, positioning it on the stator, then mount the fixed valve (34) in the shield bearing housing.
- Mount the mobile valve (35) by either screwing it or locking it, having carefully installed the seal (39) on the valve.
- Mount the outer bearing retainer (32) with the bearing retainer locking screws (40), making sure that the grease drain hole is facing the right way.
- Place the tie rods (14) in position, not forgetting the feet of the cover (380), tighten the nuts diagonally without locking them so that the feet of the cover can be positioned when it is mounted.
- Mount the fan (7) using a drift to bed it in position, or, for an aluminium fan, by heating the hub to approximately 100°C.
- Check that the motor turns freely by hand and that there is no axial play.
- Replace the cover (13) and fix it with the screws (27), replace the grease nipple (42) and its extension.
- Tighten the rod nuts (14), always diagonally, to the torque recommended in section 6.4.
- Replace the key (21).

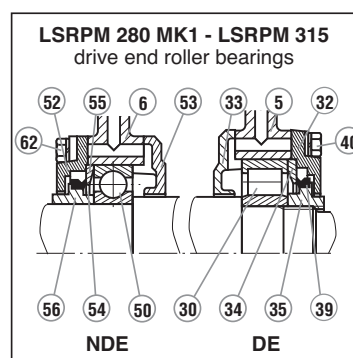
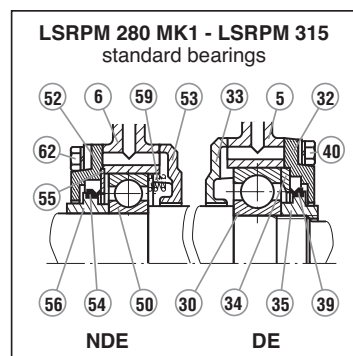

LSRPM - PLSRPM

Synchronous permanent magnet motors

LSRPM 280 MK1, LSRPM 315

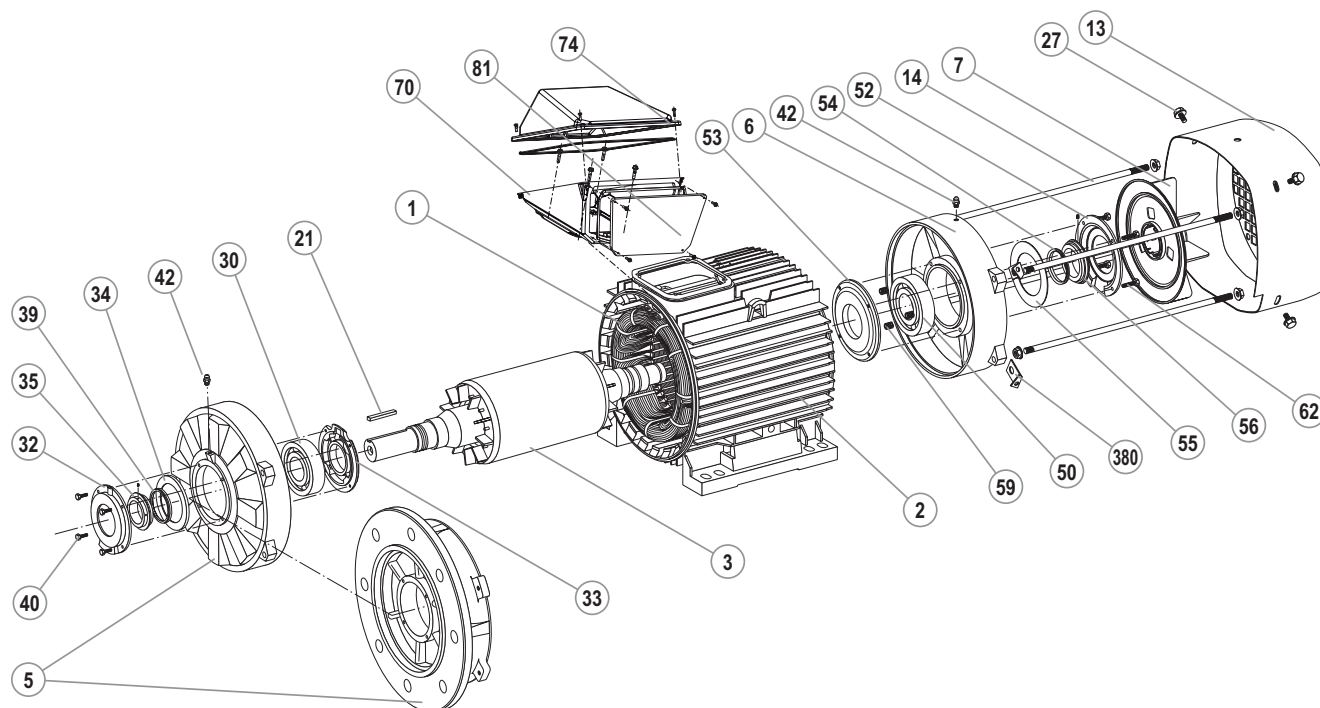

Nbr	Description	Nbr	Description	Nbr	Description
1	Wound stator	30	Drive end bearing	53	Inner non drive end bearing retainer
2	Frame	32	Outer drive end bearing retainer	54	NDE weatherproof seal
3	Rotor	33	Inner drive end bearing retainer	55	Non drive end fixed grease valve
5	Drive end shield	34	Drive end fixed grease valve	56	Non drive end mobile grease valve
6	Non drive end shield	35	Drive end mobile grease valve	59	Preloading washer or spring
7	Fan	39	Drive end seal	62	Cover fixing screw
13	Fan cover	40	Drive end cover fixing screw	70	Terminal box
14	Tie rods	42	Grease nipples	74	Terminal box lid
21	Shaft extension key	50	Non drive end bearing	81	Cable gland support plate
27	Fan cover screw	52	Outer non drive end bearing retainer	380	Protective cover feet

LSRPM - PLSRPM

Synchronous permanent magnet motors

9.7 - PLSRPM 315 LD motors

9.7.1 - Dismantling

- Remove the screws (27), the grease nipple (42) and its extension, then take off the cover (13).
- Pull out the fan (7) using a hub remover or 2 levers diametrically opposite one another, using the shield (6) for support. For an aluminium fan, heat the hub to approximately 100°C before removing it.
- Take out the key (21).
- Unscrew the tie rods (14) then remove them.
- Unscrew the DE inner bearing retainer (33) fixing screws (40) and the fixing screws (62) on the NDE bearing retainers (32) and (52), and remove the bearing retainers.
- Unscrew the «Hc» screws on the mobile valves (35 and 56) then unscrew the valves using a hook spanner or a conical bronze drift. Unscrew the valves by hand and remove them. The valves hold the seals (39 and 54) in place.
- Remove the fixed valves (34 and 35) from the bearing housings.
- Using a bronze drift, remove the shields (5 and 6) by tapping gently on the shield bosses.
- Check that the diameter of the bearing retainer (53) is smaller than that of the stator, otherwise remove the bearing (50) in accordance with the following instructions.
- Take care not to remove the rotor from the stator. This is not necessary when extracting bearings. If absolutely necessary, screw in a handle, place the motor in a vertical position and then clamp the stator as described in the procedure in the appendix.
- Remove the rotor from the stator using a hoist, taking care not to touch the winding.
- Take out the bearings (30) and (50) using a bearing remover, while protecting the end of the shaft extension with a washer. Avoid knocking the running surfaces of the shaft.
- The bearings are removed either separately or with the bearing retainers (33 and 53). To avoid damaging the bearing retainers, heat the outer bearing ring (the bearing should be discarded).
- Recover the preloading washer or springs (59) from the bearing retainer (53).

9.7.2 - Reassembly

- See section 6.2 before reassembly.
- Insert the rotor drive end inner bearing retainer (33) and the non drive end inner bearing retainer (53), not forgetting to insert the preloading springs (59).
- Fill with new grease: the correct amount of new grease for the bearing is 50% of the free space.
- Mount the new bearings (30 and 50) on the shaft, see section 6.3 on mounting bearings.
- Screw in a shackle, place the motor in a vertical position and clamp the stator as described in the procedure in the appendix.
- Using a hoist, slowly lower the rotor into the stator, taking care not to touch the winding.

⚠ Warning: the rotor exerts a very strong magnetic force.

- Place the motor in a horizontal position.
- Connect the Hall effect sensor.
- Screw a rod with the same thread diameter as the screws (40) and (62) into one of the tapped holes on the bearing retainers (33) and (53) to maintain the position of the grease nipple when refitting the shields (5 and 6).
- Check that the preloading springs are properly installed.

- Fit the NDE shield (6), positioning it on the stator, then mount the fixed valve (55) in the shield bearing housing.
- Mount the mobile valve (56) by either screwing it or locking it, having carefully installed the seal (54) on the valve.
- Mount the outer bearing retainer (52) with the bearing retainer locking screws (62), making sure that the grease drain hole is at the bottom.
- Mount the shield (5) at the drive end, positioning it on the stator, then mount the fixed valve (34) in the shield bearing housing.
- Mount the mobile valve (35) by either screwing it or locking it, having carefully installed the seal (39) on the valve.
- Mount the outer bearing retainer (32) with the bearing retainer locking screws (40), making sure that the grease drain hole is facing the right way.
- Place the tie rods (14) in position, not forgetting the feet of the cover (380), tighten the nuts diagonally without locking them so that the feet of the cover can be positioned when it is mounted.
- Mount the fan (7) using a drift to bed it in position, or, for an aluminium fan, by heating the hub to approximately 100°C.
- Check that the motor turns freely by hand and that there is no axial play.
- Replace the cover (13) and fix it with the screws (27), replace the grease nipple (42) and its extension.
- Tighten the rod nuts (14), always diagonally, to the torque recommended in section 6.4.
- Replace the key (21).

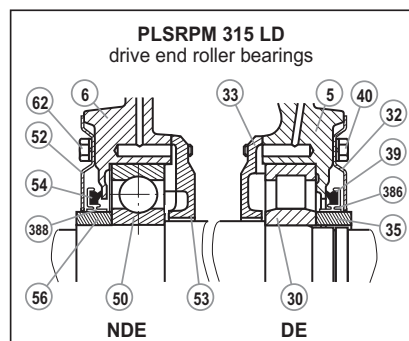
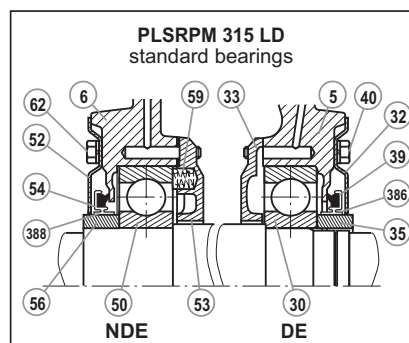

LSRPM - PLSRPM

Synchronous permanent magnet motors

PLSRPM 315 LD

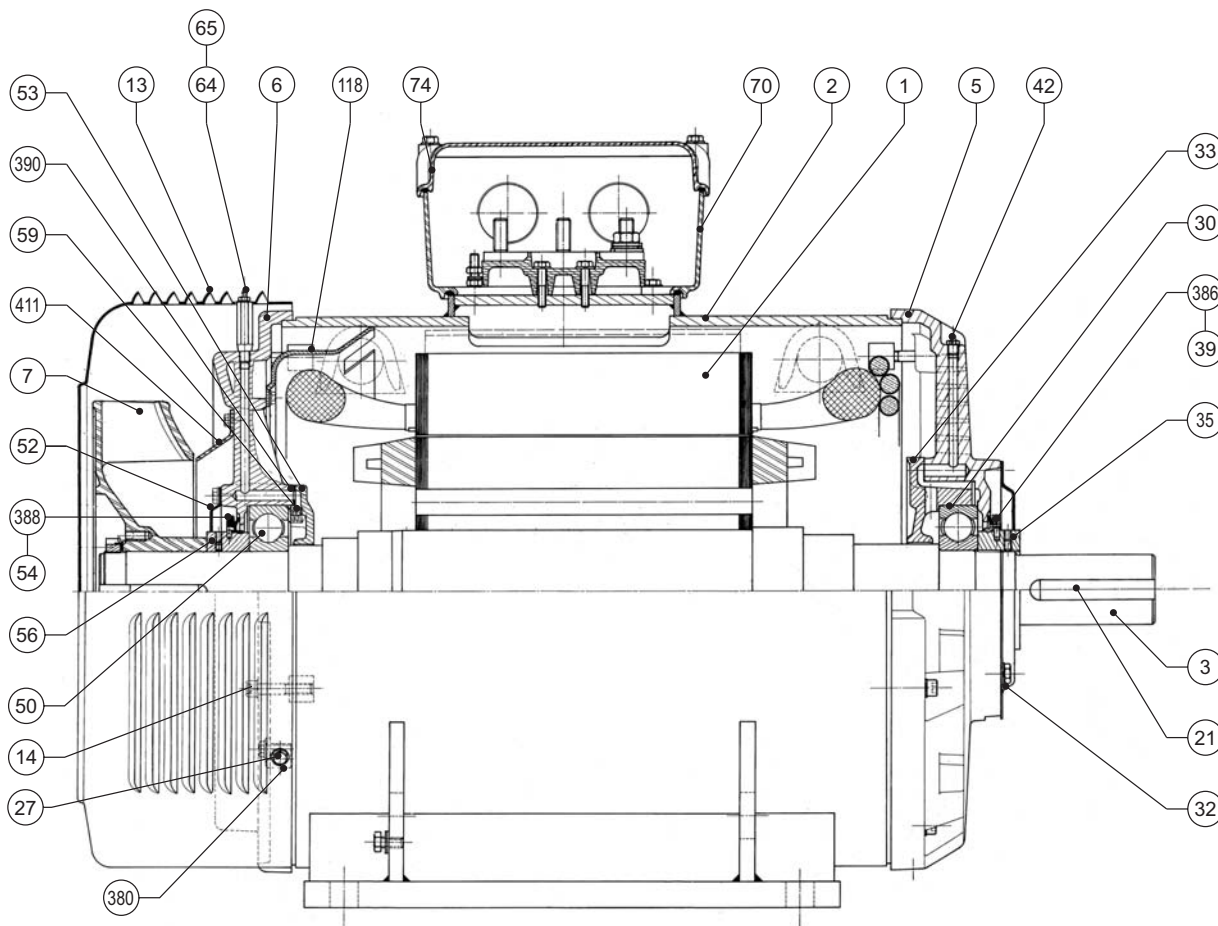

Nbr	Description	Nbr	Description	Nbr	Description
1	Wound stator	32	Outer DE bearing retainer	64	Grease nipple
2	Housing	33	Inner DE bearing retainer	65	Extension for grease nipple
3	Rotor	35	DE mobile grease valve	70	Terminal box
5	DE shield	39	Drive end seal	74	Terminal box cover
6	NDE shield	42	Grease nipples	84	Terminal block
7	Fan	50	NDE bearing	118	Internal deflector
13	Fan cover	52	Outer NDE bearing retainer	380	Cover feet
14	Tie rods	53	Inner NDE bearing retainer	386	DE seal support
21	Key	54	NDE seal	388	NDE seal support
27	Cover fixing screw	56	NDE mobile grease valve	390	NDE inner bearing retainer strut
30	DE bearing	59	Preloading washer or spring	411	External deflector

LSRPM - PLSRPM

Synchronous permanent magnet motors

10 - APPENDICES

Placing the motor in the vertical position

Warning: On some motor sizes, although the rotor's magnetic force on the stator is very high, the force is not sufficient to support the stator when the motor is suspended in a vertical position. It is therefore important for safety reasons to leave the DE shield screwed onto the housing.

In addition, take care not to tilt the motor with the NDE shaft extension resting on the floor. We therefore recommend you reinstall the cover at the non-drive end of the motor before performing the operation. This could also be left in place when removing the rotor if the clamping system allows.

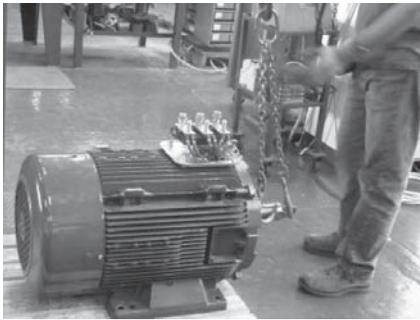
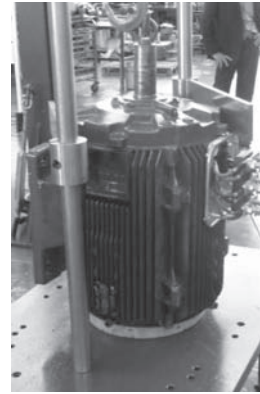

- Put the motor on the workbench or leave it on a pallet.
- Replace the DE shield if it had previously been removed.
- Replace the cover without replacing the NDE shield.
- Install a shackle on the shaft extension.



- Raise the motor to the vertical with a lifting block, while tilting the motor on the cover (this has a bevelled part on the underside that can keep the motor stable during the operation).

- Put the motor down on the table. If it is necessary to remove the cover, take care to pass the NDE shaft extension through the specially-designed hole in the table. Make sure that the end turns do not protrude from the housing. Otherwise, a protective «container» should be installed between the winding and the housing.
- Remove the DE shield.

Clamping the stator

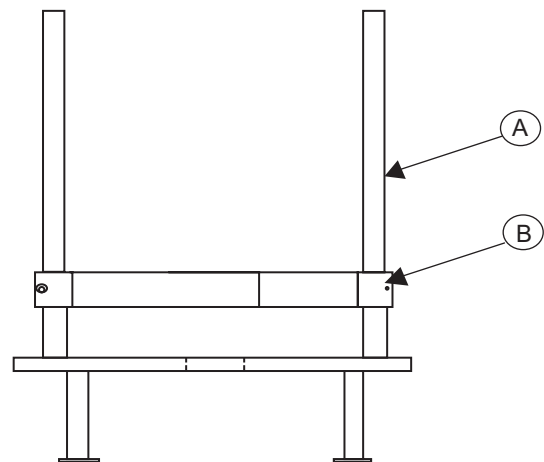

- Place the arms of the clamping table on the DE shield of the housing bore. Depending on the size, it may also be possible to use the terminal box to help you.

LSRPM - PLSRPM

Synchronous permanent magnet motors

Procedure for assembling the encoder

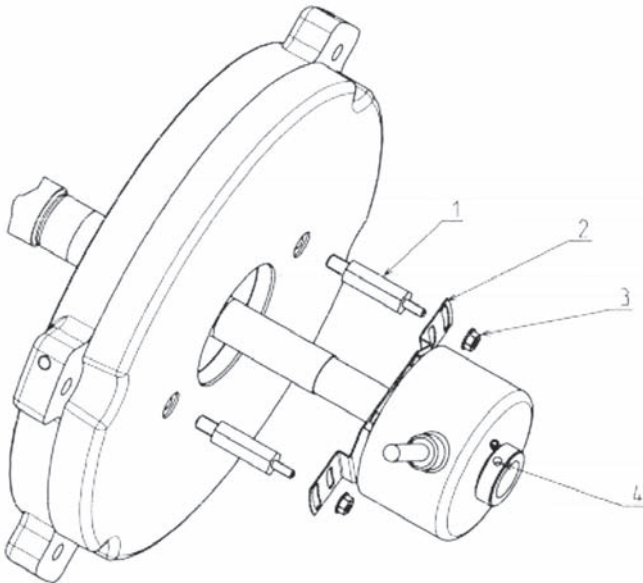

- Slide the encoder onto the shaft until it comes into contact with the ATD (item 2) and spacers (item 1) (do not compress them). The M3 threaded part of the spacers should be slipped into the ATD (encoder mounting feet) (item 2).

- Fasten the encoder ATD to the spacers with two M3 «COMBY» lock nuts using a 5.5 tube wrench (tightening torque 1 N.m) (item 3).

Caution, hold each foot during tightening to avoid twisting them.

ATD = Anti-Torque Device

Procedure for tightening the encoder hexagonal socket head screw(s) on the shaft (item 4).

- Put 1 drop of Loctite 643 removable threadlocker on each of the screws.

- Semi-tighten the first screw, then the second.

- Fully tighten the first screw, then the second (tightening torque between 1.5 and 2 N.m).

- Screw the female connector onto the male.

- Note: If self-cooled motor

Screw in the fan bushing (224) at the end of the shaft.



MOTEURS LEROY-SOMER 16015 ANGOULÊME CEDEX - FRANCE

338 567 258 RCS ANGOULÊME
S.A.S. au capital de 65 800 512 €

www.leroy-somer.com