



## *User guide*

---

# ***DIGISTART D3***

---

Reference: 4259 en - 2015.04 / f

## **General Information**

The manufacturer accepts no liability for any consequences resulting from inappropriate, negligent or incorrect installation or adjustment of the optional parameters of the equipment or from mismatching the starter with the motor.

The contents of this guide are believed to be correct at the time of printing. In the interests of commitment to a policy of continuous development and improvement, the manufacturer reserves the right to change the specification of the product or its performance, or the content of the guide without notice.

All rights reserved. No parts of this guide may be reproduced or transmitted in any form or by any means, electrical or mechanical including, photocopying, recording or by an information storage or retrieval system, without permission in writing from the publisher.

## **Software Version**

This product is supplied with the latest version of user-interface and machine control software. If this product is to be used in a new or existing system with other starters, there may be some differences between their software and the software in this product. These differences may cause the product to function differently. This may also apply to starters returned from the LEROY SOMER Service Centre.

If there is any doubt, please contact LEROY SOMER or your local Distributor.

## **Environmental Statement**

LEROY SOMER is committed to minimising the impacts of its manufacturing operations. To this end, we operate an Environmental Management System (EMS) which is certified to the International Standard ISO 14001.

When the products eventually reach the end of their useful life, they can very easily be dismantled into their major component parts for efficient recycling. Many parts snap together and can be separated without the use of tools, while other parts are secured with conventional screws.

Product packaging is of good quality and can be re-used. Large products are packed in wooden crates, while smaller products come in strong cardboard cartons which themselves have a high recycled fibre content. If not re-used, these containers can be recycled. Polythene, used on the protective film and bags from wrapping product, can be recycled in the same way.

When preparing to recycle or dispose of any product or packaging, please observe local legislation and best practice.

## **REACH Legislation**

EC Regulation 1907/2006 on the Registration, Evaluation, Authorisation and restriction of Chemicals (REACH) requires the supplier of an article to inform the recipient if it contains more than a specified proportion of any substance which is considered by the European Chemicals Agency (ECHA) to be a Substance of Very High Concern (SVHC) and is therefore listed by them as a candidate for compulsory authorisation.

For current information on how this requirement applies in relation to specific LEROY SOMER products, please approach your usual contact in the first instance.

For the latest manuals and software, please visit our website.

---

# Contents

---

|            |   |           |
|------------|---|-----------|
| <b>1.</b>  | <b>Safety Information .....</b>                   | <b>5</b>  |
| 1.1        | Warnings, cautions and notes .....                | 5         |
| 1.2        | Electrical safety - general warning .....         | 5         |
| 1.3        | System design and safety of personnel .....       | 5         |
| 1.4        | Environmental limits .....                        | 5         |
| 1.5        | Compliance with regulations .....                 | 5         |
| 1.6        | Motor .....                                       | 5         |
| 1.7        | Adjusting parameters .....                        | 5         |
| 1.8        | Electrical installation .....                     | 6         |
| <b>2.</b>  | <b>Rating Data .....</b>                          | <b>7</b>  |
| 2.1        | Model code .....                                  | 7         |
| 2.2        | Current ratings .....                             | 7         |
| <b>3.</b>  | <b>Mechanical Installation .....</b>              | <b>12</b> |
| 3.1        | Dimensions and weights .....                      | 12        |
| 3.2        | Physical installation .....                       | 15        |
| 3.3        | Busbar adjustment procedure .....                 | 15        |
| <b>4.</b>  | <b>Electrical Installation .....</b>              | <b>17</b> |
| 4.1        | Terminal layout .....                             | 17        |
| 4.2        | Control connections .....                         | 21        |
| 4.3        | Power connections .....                           | 22        |
| 4.4        | Fuse information .....                            | 26        |
| 4.5        | Bypass contactor .....                            | 32        |
| 4.6        | Main contactor .....                              | 32        |
| 4.7        | Circuit breaker .....                             | 32        |
| 4.8        | Power factor correction .....                     | 32        |
| 4.9        | EMC (electromagnetic compatibility) .....         | 32        |
| <b>5.</b>  | <b>Keypad and Status .....</b>                    | <b>33</b> |
| 5.1        | Keypad .....                                      | 33        |
| 5.2        | Removing and replacing the keypad .....           | 33        |
| 5.3        | Synchronising the keypad and the starter .....    | 34        |
| 5.4        | Displays .....                                    | 34        |
| <b>6.</b>  | <b>Quick Start Commissioning .....</b>            | <b>36</b> |
| 6.1        | Control wiring .....                              | 36        |
| 6.2        | Setup procedure .....                             | 37        |
| <b>7.</b>  | <b>Operation .....</b>                            | <b>38</b> |
| 7.1        | Start, stop and reset commands .....              | 38        |
| 7.2        | Soft start methods .....                          | 38        |
| 7.3        | Stop methods .....                                | 40        |
| 7.4        | Jog operation .....                               | 44        |
| 7.5        | Inside delta operation .....                      | 44        |
| <b>8.</b>  | <b>Programming .....</b>                          | <b>45</b> |
| 8.1        | Programming menu .....                            | 45        |
| 8.2        | Access code .....                                 | 45        |
| 8.3        | Adjustment lock .....                             | 46        |
| 8.4        | Load defaults .....                               | 46        |
| 8.5        | Quick setup details .....                         | 47        |
| 8.6        | Standard menu .....                               | 48        |
| 8.7        | Advanced menu .....                               | 49        |
| 8.8        | Parameter descriptions .....                      | 53        |
| 8.9        | Maintenance tools .....                           | 67        |
| <b>9.</b>  | <b>Diagnostics .....</b>                          | <b>71</b> |
| 9.1        | Protection responses .....                        | 71        |
| 9.2        | Trip messages .....                               | 71        |
| 9.3        | General faults .....                              | 74        |
| <b>10.</b> | <b>Application Examples .....</b>                 | <b>76</b> |
| 10.1       | Installation with main contactor .....            | 76        |
| 10.2       | Installation with external bypass contactor ..... | 77        |
| 10.3       | Emergency run operation .....                     | 78        |
| 10.4       | Auxiliary trip circuit .....                      | 79        |

|            |  |           |
|------------|--|-----------|
| 10.5       | DC brake with external zero speed sensor ..... | 80        |
| 10.6       | Soft braking .....                             | 81        |
| 10.7       | Two-speed motor .....                          | 82        |
| 10.8       | Slip-ring motor.....                           | 83        |
| <b>11.</b> | <b>Technical Data.....</b>                     | <b>85</b> |
| 11.1       | UL compliant installation .....                | 87        |
| <b>12.</b> | <b>Maintenance .....</b>                       | <b>88</b> |
| 12.1       | Care .....                                     | 88        |
| 12.2       | Measuring the motor current.....               | 88        |
| 12.3       | Measuring the input and output power.....      | 88        |
| 12.4       | Exchanging products.....                       | 88        |
| <b>13.</b> | <b>Options .....</b>                           | <b>89</b> |

# 1. Safety Information

## 1.1 Warnings, cautions and notes



A Warning contains information which is essential for avoiding a safety hazard.



A Caution contains information which is necessary for avoiding a risk of damage to the product or other equipment.

**NOTE** A Note contains information which helps to ensure correct operation of the product.

## 1.2 Electrical safety - general warning

The voltages used in the starter can cause severe electrical shock and/or burns, and could be lethal. Extreme care is necessary at all times when working with or adjacent to the starter.

Specific warnings are given at the relevant places in this guide.

## 1.3 System design and safety of personnel

The starter is intended as a component for professional incorporation into complete equipment or a system. If installed incorrectly, the starter may present a safety hazard.

The starter uses high voltages and currents, carries stored electrical energy, and is used to control equipment which can cause injury.

Close attention is required to the electrical installation and the system design to avoid hazards either in normal operation or in the event of equipment malfunction. System design, installation, commissioning and maintenance must be carried out by personnel who have the necessary training and experience. They must read this safety information and this guide carefully.

**None of the starter functions must be used to ensure safety of personnel, ie they must not be used for safety-related functions.**

Careful consideration must be given to the functions of the starter which might result in a hazard, either through their intended behaviour or through incorrect operation due to a fault. In any application where a malfunction of the starter or its control system could lead to or allow damage, loss or injury, a risk analysis must be carried out, and where necessary, further measures taken to reduce the risk.

The system designer is responsible for ensuring that the complete system is safe and designed correctly according to the relevant safety standards.

## 1.4 Environmental limits

Instructions regarding transport, storage, installation and use of the starter must be complied with, including the specified environmental limits. Starters must not be subjected to excessive physical force.

## 1.5 Compliance with regulations

The installer is responsible for complying with all relevant regulations, such as national wiring regulations, accident prevention regulations and electromagnetic compatibility (EMC) regulations. Particular attention must be given to the cross-sectional areas of conductors, the selection of fuses or other protection, and protective ground connections.

Within the European Union, all machinery in which this product is used must comply with the following directives:

2006/42/EC: Safety of machinery.

2004/108/EC: Electromagnetic Compatibility.

## 1.6 Motor

Ensure the motor is installed in accordance with the manufacturer's recommendations. Ensure the motor shaft is not exposed.

The values of the motor parameters set in the starter affect the protection of the motor. The default values in the starter should not be relied upon. It is essential that the correct value is entered in Pr **1A Motor Full Load Current**. This affects the thermal protection of the motor.

## 1.7 Adjusting parameters

Some parameters have a profound effect on the operation of the starter. They must not be altered without careful consideration of the impact on the controlled system. Measures must be taken to prevent unwanted changes due to error or tampering.

## 1.8 Electrical installation

### 1.8.1 Electrical shock risk

The voltages present in the following locations can cause severe electric shock and may be lethal:

- AC supply cables and connections
- Output cables and connections
- Many internal parts of the starter, and external option units

The AC supply must be disconnected from the starter using an approved isolation device before any cover is removed from the starter or before any servicing work is performed.



#### **WARNING - ELECTRICAL SHOCK HAZARD**

Models D3-1x-0500-B to D3-16-1600-N: The busbar and heatsink must be treated as live whenever the unit has mains voltage connected (including when the starter is tripped or waiting for a command).

### 1.8.2 Power-up procedure

**Always apply control voltage before (or with) mains voltage.**

D3-1x-0023-B to D3-1x-0105-B: After transportation, mechanical shock or rough handling there is a possibility that the bypass contactor may have latched into the on state. To prevent the possibility of the motor starting immediately, on first commissioning or operation after transportation, always ensure that the control supply is applied before the power, so that the contactor state is initialised.

### 1.8.3 STOP function

The STOP function does not remove dangerous voltages from the starter, the motor or any external option units.

### 1.8.4 Stored charge

The starter contains capacitors that remain charged to a potentially dangerous voltage after the AC supply has been disconnected. If the starter has been energised, the AC supply must be isolated at least two minutes before work may continue.

Normally, the capacitors are discharged by an internal resistor. Under certain, unusual fault conditions, the capacitors may fail to discharge. Do not assume that the capacitors have discharged. To protect the user and the equipment, take due care when carrying out any work on the starter.

### 1.8.5 Equipment supplied by plug and socket

The control supply terminals of the starter are connected to the internal capacitors through rectifier diodes which are not intended to give safety isolation. If the plug terminals can be touched when the plug is disconnected from the socket, a means of automatically isolating the plug from the starter must be used (e.g. a latching relay).

### 1.8.6 Short circuit

Digistart D3 soft starters are not short circuit proof. After severe overload or short circuit, the operation of the soft starter should be fully tested by an authorised service agent.

### 1.8.7 Auto-start

Use the auto-start feature with caution. Read all the notes related to auto-start before operation.

## 2. Rating Data

### 2.1 Model code

Figure 2-1 Model code explanation

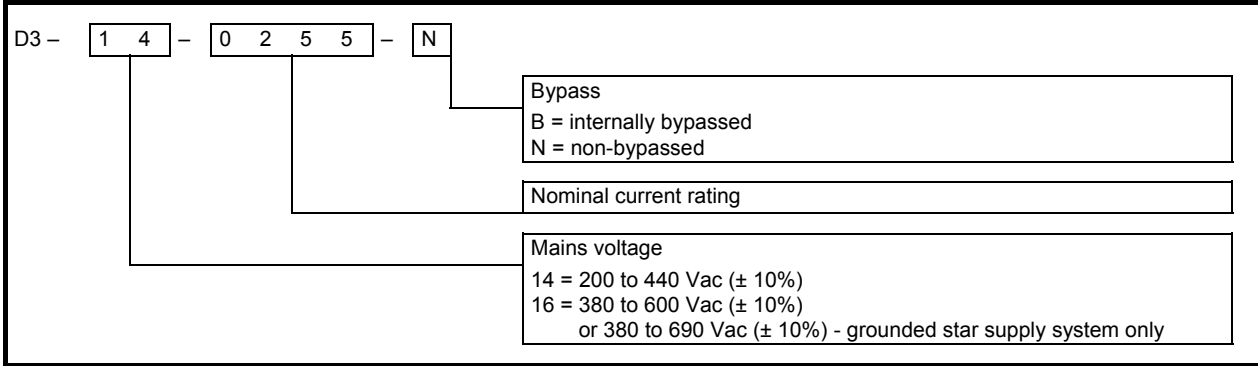

Digistart D3 can only be used on 690V IT supply equipped with surge protectors. Please contact LEROY-SOMER or your local distributor.

### 2.2 Current ratings

Contact your local supplier for ratings under operating conditions not covered by these ratings charts.

#### 2.2.1 Current ratings for bypass operation

##### AC53b utilisation code

The AC53b utilisation code defines the current rating and standard operating conditions for a bypassed soft starter (internally bypassed, or installed with an external bypass contactor).

The soft starter's current rating determines the maximum motor size it can be used with. The soft starter's rating depends on the number of starts per hour and the length and current level of the start.

The soft starter's current rating is only valid when used within the conditions specified in the utilisation code. The soft starter may have a higher or lower current rating in different operating conditions.

Figure 2-2 AC53b utilisation code

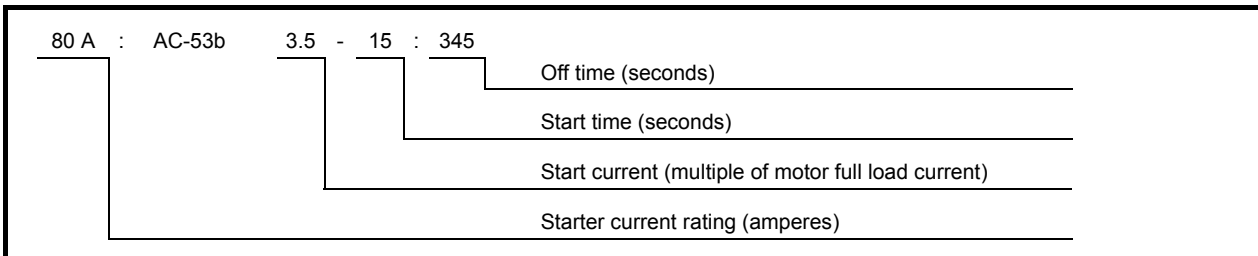

**Starter current rating:** The full load current rating of the soft starter given the parameters detailed in the remaining sections of the utilisation code.

**Start current:** The maximum available start current.

**Start time:** The maximum allowable start time.

**Off time:** The minimum allowable time between the end of one start and the beginning of the next start.

**Table 2-1 Current ratings - in-line (3-wire) connection, bypassed operation**

| Model        | AC53b 3.0-10:350<br>40 °C <1000 metres | AC53b 3.5-15:345<br>40 °C <1000 metres | AC53b 4.0-20:340<br>40 °C <1000 metres | AC53b 4.5-30:330<br>40 °C <1000 metres |
|--------------|--|--|--|--|
| D3-1x-0023-B | 23 A                                   | 20 A                                   | 17 A                                   | 15 A                                   |
| D3-1x-0043-B | 43 A                                   | 37 A                                   | 31 A                                   | 26 A                                   |
| D3-1x-0053-B | 53 A                                   | 53 A                                   | 46 A                                   | 37 A                                   |
| Model        | AC53b 3.0-10:590<br>40 °C <1000 metres | AC53b 3.5-15:585<br>40 °C <1000 metres | AC53b 4.0-20:580<br>40 °C <1000 metres | AC53b 4.5-30:570<br>40 °C <1000 metres |
| D3-1x-0076-B | 76 A                                   | 64 A                                   | 55 A                                   | 47 A                                   |
| D3-1x-0097-B | 97 A                                   | 82 A                                   | 69 A                                   | 58 A                                   |
| D3-1x-0105-B | 105 A                                  | 105 A                                  | 95 A                                   | 78 A                                   |
| D3-1x-0145-B | 145 A                                  | 123 A                                  | 106 A                                  | 90 A                                   |
| D3-1x-0170-B | 170 A                                  | 145 A                                  | 121 A                                  | 97 A                                   |
| D3-1x-0200-B | 200 A                                  | 189 A                                  | 160 A                                  | 134 A                                  |
| D3-1x-0220-B | 220 A                                  | 210 A                                  | 178 A                                  | 148 A                                  |
| D3-1x-0255-B | 255 A                                  | 231 A                                  | 201 A                                  | 176 A                                  |
| D3-1x-0350-B | 350 A                                  | 329 A                                  | 284 A                                  | 244 A                                  |
| D3-1x-0425-B | 425 A                                  | 411 A                                  | 355 A                                  | 305 A                                  |
| D3-1x-0500-B | 500 A                                  | 445 A                                  | 383 A                                  | 326 A                                  |
| D3-1x-0700-B | 700 A                                  | 592 A                                  | 512 A                                  | 438 A                                  |
| D3-1x-0820-B | 820 A                                  | 705 A                                  | 606 A                                  | 516 A                                  |
| D3-1x-0920-B | 920 A                                  | 804 A                                  | 684 A                                  | 571 A                                  |
| D3-1x-1000-B | 1000 A                                 | 936 A                                  | 796 A                                  | 664 A                                  |

**NOTE** For models D3-1x-0255-N to D3-16-1600-N, these ratings are valid only when externally bypassed using a suitable contactor.

**Table 2-2 Current ratings - in-line (3-wire) connection, externally bypassed**

| Model        | AC53b 3.0-10:590<br>40 °C <1000 metres | AC53b 3.5-15:585<br>40 °C <1000 metres | AC53b 4.0-20:580<br>40 °C <1000 metres | AC53b 4.5-30:570<br>40 °C <1000 metres |
|--------------|--|--|--|--|
| D3-1x-0255-N | 255 A                                  | 231 A                                  | 201 A                                  | 176 A                                  |
| D3-1x-0360-N | 360 A                                  | 360 A                                  | 310 A                                  | 263 A                                  |
| D3-1x-0430-N | 430 A                                  | 430 A                                  | 368 A                                  | 309 A                                  |
| D3-1x-0650-N | 650 A                                  | 650 A                                  | 561 A                                  | 455 A                                  |
| D3-1x-0790-N | 790 A                                  | 790 A                                  | 714 A                                  | 579 A                                  |
| D3-1x-0930-N | 930 A                                  | 930 A                                  | 829 A                                  | 661 A                                  |
| D3-16-1200-N | 1200 A                                 | 1200 A                                 | 1200 A                                 | 1071 A                                 |
| D3-16-1410-N | 1410 A                                 | 1410 A                                 | 1319 A                                 | 1114 A                                 |
| D3-16-1600-N | 1600 A                                 | 1600 A                                 | 1600 A                                 | 1353 A                                 |

|                    |             |                         |                         |                   |                           |           |             |             |                      |                |             |         |
|--------------------|-------------|-------------------------|-------------------------|-------------------|---------------------------|-----------|-------------|-------------|----------------------|----------------|-------------|---------|
| Safety Information | Rating Data | Mechanical Installation | Electrical Installation | Keypad and Status | Quick Start Commissioning | Operation | Programming | Diagnostics | Application Examples | Technical Data | Maintenance | Options |
|--------------------|-------------|-------------------------|-------------------------|-------------------|---------------------------|-----------|-------------|-------------|----------------------|----------------|-------------|---------|

**Table 2-3 Current ratings - inside delta (6-wire) connection, bypassed operation**

| Model        | AC53b 3.0-10:350<br>40 °C <1000 metres | AC53b 3.5-15:345<br>40 °C <1000 metres | AC53b 4.0-20:340<br>40 °C <1000 metres | AC53b 4.5-30:330<br>40 °C <1000 metres |
|--------------|--|--|--|--|
| D3-1x-0023-B | 34 A                                   | 30 A                                   | 26 A                                   | 22 A                                   |
| D3-1x-0043-B | 64 A                                   | 59 A                                   | 51 A                                   | 44 A                                   |
| D3-1x-0053-B | 79 A                                   | 79 A                                   | 69 A                                   | 55 A                                   |
| Model        | AC53b 3.0-10:590<br>40 °C <1000 metres | AC53b 3.5-15:585<br>40 °C <1000 metres | AC53b 4.0-20:580<br>40 °C <1000 metres | AC53b 4.5-30:570<br>40 °C <1000 metres |
| D3-1x-0076-B | 114 A                                  | 96 A                                   | 83 A                                   | 70 A                                   |
| D3-1x-0097-B | 145 A                                  | 123 A                                  | 104 A                                  | 87 A                                   |
| D3-1x-0105-B | 157 A                                  | 157 A                                  | 143 A                                  | 117 A                                  |
| D3-1x-0145-B | 217 A                                  | 184 A                                  | 159 A                                  | 136 A                                  |
| D3-1x-0170-B | 255 A                                  | 217 A                                  | 181 A                                  | 146 A                                  |
| D3-1x-0200-B | 300 A                                  | 283 A                                  | 241 A                                  | 200 A                                  |
| D3-1x-0220-B | 330 A                                  | 315 A                                  | 268 A                                  | 223 A                                  |
| D3-1x-0255-B | 382 A                                  | 346 A                                  | 302 A                                  | 264 A                                  |
| D3-1x-0350-B | 525 A                                  | 494 A                                  | 427 A                                  | 366 A                                  |
| D3-1x-0425-B | 638 A                                  | 617 A                                  | 533 A                                  | 458 A                                  |
| D3-1x-0500-B | 750 A                                  | 668 A                                  | 575 A                                  | 490 A                                  |
| D3-1x-0700-B | 1050 A                                 | 889 A                                  | 768 A                                  | 658 A                                  |
| D3-1x-0820-B | 1230 A                                 | 1058 A                                 | 910 A                                  | 774 A                                  |
| D3-1x-0920-B | 1380 A                                 | 1206 A                                 | 1026 A                                 | 857 A                                  |
| D3-1x-1000-B | 1500 A                                 | 1404 A                                 | 1194 A                                 | 997 A                                  |

**NOTE** For models D3-1x-0255-N to D3-16-1600-N, these ratings are valid only when externally bypassed using a suitable contactor.

**Table 2-4 Current ratings - inside delta (6-wire) connection, externally bypassed**

| Model        | AC53b 3.0-10:590<br>40 °C <1000 metres | AC53b 3.5-15:585<br>40 °C <1000 metres | AC53b 4.0-20:580<br>40 °C <1000 metres | AC53b 4.5-30:570<br>40 °C <1000 metres |
|--------------|--|--|--|--|
| D3-1x-0255-N | 382 A                                  | 346 A                                  | 302 A                                  | 264 A                                  |
| D3-1x-0360-N | 540 A                                  | 540 A                                  | 465 A                                  | 395 A                                  |
| D3-1x-0430-N | 645 A                                  | 645 A                                  | 552 A                                  | 464 A                                  |
| D3-1x-0650-N | 975 A                                  | 975 A                                  | 842 A                                  | 683 A                                  |
| D3-1x-0790-N | 1185 A                                 | 1185 A                                 | 1071 A                                 | 868 A                                  |
| D3-1x-0930-N | 1395 A                                 | 1395 A                                 | 1244 A                                 | 992 A                                  |
| D3-16-1200-N | 1800 A                                 | 1800 A                                 | 1800 A                                 | 1606 A                                 |
| D3-16-1410-N | 2115 A                                 | 2115 A                                 | 1979 A                                 | 1671 A                                 |
| D3-16-1600-N | 2400 A                                 | 2400 A                                 | 2400 A                                 | 2030 A                                 |

## 2.2.2 Current ratings for continuous operation (not bypassed)

### AC53a utilisation code

The AC53a Utilisation Code defines the current rating and standard operating conditions for a non-bypassed soft starter.

The soft starter's current rating determines the maximum motor size it can be used with. The soft starter's rating depends on the number of starts per hour, the length and current level of the start, and the percentage of the operating cycle that the soft starter will be running (passing current).

The soft starter's current rating is only valid when used within the conditions specified in the utilisation code. The soft starter may have a higher or lower current rating in different operating conditions.

Figure 2-3 AC53a utilisation code

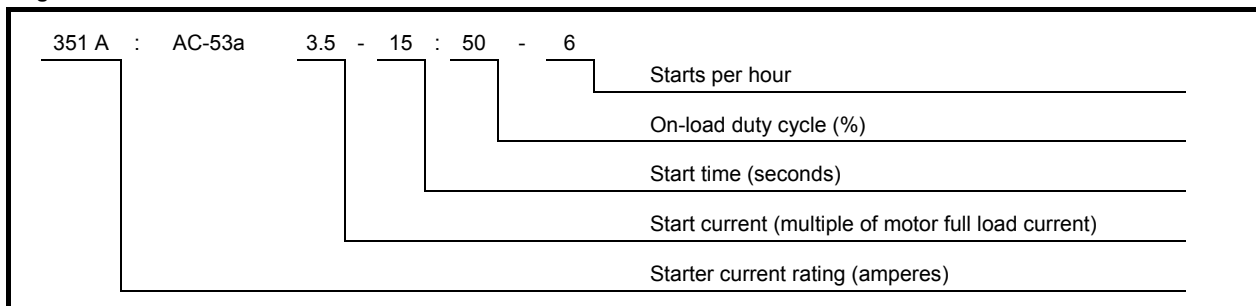

**Starter current rating:** The full load current rating of the soft starter given the parameters detailed in the remaining sections of the utilisation code.

**Start current:** The maximum available start current.

**Start time:** The maximum allowable start time.

**On-load duty cycle:** The maximum percentage of each operating cycle that the soft starter can operate.

**Starts per hour:** The maximum allowable number of starts per hour.

Table 2-5 Current ratings - in-line (3-wire) connection, non-bypassed operation

| Model        | AC53a 3-10:50-6<br>40 °C <1000 metres | AC53a 3.5-15:50-6<br>40 °C <1000 metres | AC53a 4-20:50-6<br>40 °C <1000 metres | AC53a 4.5-30:50-6<br>40 °C <1000 metres |
|--------------|---------------------------------------|---|---------------------------------------|---|
| D3-1x-0255-N | 255 A                                 | 222 A                                   | 195 A                                 | 171 A                                   |
| D3-1x-0360-N | 360 A                                 | 351 A                                   | 303 A                                 | 259 A                                   |
| D3-1x-0430-N | 430 A                                 | 413 A                                   | 355 A                                 | 301 A                                   |
| D3-1x-0650-N | 650 A                                 | 629 A                                   | 532 A                                 | 437 A                                   |
| D3-1x-0790-N | 790 A                                 | 790 A                                   | 694 A                                 | 567 A                                   |
| D3-1x-0930-N | 930 A                                 | 930 A                                   | 800 A                                 | 644 A                                   |
| D3-16-1200-N | 1200 A                                | 1200 A                                  | 1135 A                                | 983 A                                   |
| D3-16-1410-N | 1410 A                                | 1355 A                                  | 1187 A                                | 1023 A                                  |
| D3-16-1600-N | 1600 A                                | 1600 A                                  | 1433 A                                | 1227 A                                  |

Table 2-6 Current ratings - inside delta (6-wire) connection, non-bypassed operation

| Model        | AC53a 3-10:50-6<br>40 °C <1000 metres | AC53a 3.5-15:50-6<br>40 °C <1000 metres | AC53a 4-20:50-6<br>40 °C <1000 metres | AC53a 4.5-30:50-6<br>40 °C <1000 metres |
|--------------|---------------------------------------|---|---------------------------------------|---|
| D3-1x-0255-N | 382 A                                 | 334 A                                   | 293 A                                 | 257 A                                   |
| D3-1x-0360-N | 540 A                                 | 527 A                                   | 455 A                                 | 388 A                                   |
| D3-1x-0430-N | 645 A                                 | 620 A                                   | 533 A                                 | 451 A                                   |
| D3-1x-0650-N | 975 A                                 | 943 A                                   | 798 A                                 | 656 A                                   |
| D3-1x-0790-N | 1185 A                                | 1185 A                                  | 1041 A                                | 850 A                                   |
| D3-1x-0930-N | 1395 A                                | 1395 A                                  | 1200 A                                | 966 A                                   |
| D3-16-1200-N | 1800 A                                | 1800 A                                  | 1702 A                                | 1474 A                                  |
| D3-16-1410-N | 2115 A                                | 2033 A                                  | 1780 A                                | 1535 A                                  |
| D3-16-1600-N | 2400 A                                | 2400 A                                  | 2149 A                                | 1840 A                                  |

### 2.2.3 Minimum and maximum current settings

Table 2-7 Minimum and maximum current settings, internally bypassed models

| Model        | In-line connection |         | Inside delta connection |         |
|--------------|--------------------|---------|-------------------------|---------|
|              | Minimum            | Maximum | Minimum                 | Maximum |
| D3-1x-0023-B | 5 A                | 23 A    | 5 A                     | 34 A    |
| D3-1x-0043-B | 9 A                | 43 A    | 9 A                     | 64 A    |
| D3-1x-0053-B | 11 A               | 53 A    | 11 A                    | 79 A    |
| D3-1x-0076-B | 15 A               | 76 A    | 15 A                    | 114 A   |
| D3-1x-0097-B | 19 A               | 97 A    | 19 A                    | 145 A   |
| D3-1x-0105-B | 21 A               | 105 A   | 21 A                    | 157 A   |
| D3-1x-0145-B | 29 A               | 145 A   | 29 A                    | 217 A   |
| D3-1x-0170-B | 34 A               | 170 A   | 34 A                    | 255 A   |
| D3-1x-0200-B | 40 A               | 200 A   | 40 A                    | 300 A   |
| D3-1x-0220-B | 44 A               | 220 A   | 44 A                    | 330 A   |
| D3-1x-0255-B | 51 A               | 255 A   | 51 A                    | 382 A   |
| D3-1x-0350-B | 70 A               | 350 A   | 70 A                    | 525 A   |
| D3-1x-0425-B | 85 A               | 425 A   | 85 A                    | 638 A   |
| D3-1x-0500-B | 100 A              | 500 A   | 100 A                   | 750 A   |
| D3-1x-0700-B | 140 A              | 700 A   | 140 A                   | 1050 A  |
| D3-1x-0820-B | 164 A              | 820 A   | 164 A                   | 1230 A  |
| D3-1x-0920-B | 184 A              | 920 A   | 184 A                   | 1380 A  |
| D3-1x-1000-B | 200 A              | 1000 A  | 200 A                   | 1500 A  |

Table 2-8 Minimum and maximum current settings, externally bypassed models

| Model        | In-line connection |         | Inside delta connection |         |
|--------------|--------------------|---------|-------------------------|---------|
|              | Minimum            | Maximum | Minimum                 | Maximum |
| D3-1x-0255-N | 51 A               | 255 A   | 51 A                    | 382 A   |
| D3-1x-0360-N | 72 A               | 360 A   | 72 A                    | 540 A   |
| D3-1x-0430-N | 86 A               | 430 A   | 86 A                    | 645 A   |
| D3-1x-0650-N | 130 A              | 650 A   | 130 A                   | 975 A   |
| D3-1x-0790-N | 158 A              | 790 A   | 158 A                   | 1185 A  |
| D3-1x-0930-N | 186 A              | 930 A   | 186 A                   | 1395 A  |
| D3-16-1200-N | 240 A              | 1200 A  | 240 A                   | 1800 A  |
| D3-16-1410-N | 282 A              | 1410 A  | 282 A                   | 2115 A  |
| D3-16-1600-N | 320 A              | 1600 A  | 320 A                   | 2400 A  |

### 3. Mechanical Installation



Digistart D3 models D3-1x-0145-B to D3-16-1600-N weigh in excess of 15 kg (33 lb). Use appropriate safeguards when lifting these models.



Models D3-1x-0145-B to D3-1x-1000-B and D3-1x-0255-N to D3-16-1600-N are intended to be mounted in an enclosure which prevents access except by trained and authorised personnel, and which prevents the ingress of contamination. The complete range is designed for use in an environment classified as Pollution Degree 3 in accordance with IEC60664-1. This means conductive pollution or dry, non-conductive pollution which becomes conductive due to condensation is acceptable.

It is the installer's responsibility to ensure that any enclosure which allows access to models D3-1x-0145-B to D3-1x-1000-B and D3-1x-0255-N to D3-16-1600-N while the product is energized, provides protection against contact and ingress requirements of IP20.

Models D3-1x-0145-B to D3-1x-1000-B can be installed with optional finger guards, in which case they do not need to be mounted in an enclosure.

#### 3.1 Dimensions and weights

**NOTE** For further details on Digistart D3 dimensions and corresponding CAD drawings please visit [www.leroy-somer.com](http://www.leroy-somer.com).

Table 3-1 Dimensions and weights

| Model        | Size | A<br>mm<br>(in) | B<br>mm<br>(in) | C<br>mm<br>(in) | D<br>mm<br>(in) | E<br>mm<br>(in) | F<br>mm<br>(in) | G<br>mm<br>(in) | H<br>mm<br>(in) | I<br>mm<br>(in) | Weight<br>kg<br>(lb) |               |               |               |               |                |                |              |              |             |
|--------------|------|-----------------|-----------------|-----------------|-----------------|-----------------|-----------------|-----------------|-----------------|-----------------|----------------------|---------------|---------------|---------------|---------------|----------------|----------------|--------------|--------------|-------------|
| D3-1x-0023-B | G1B  | 156<br>(6.1)    | 124<br>(4.9)    | 295<br>(11.6)   | 278<br>(10.9)   | 192             | n/a             | n/a             | n/a             | n/a             | 4.2                  |               |               |               |               |                |                |              |              |             |
| D3-1x-0043-B |      |                 |                 |                 |                 | (7.6)           |                 |                 |                 |                 | 4.5 (9.9)            |               |               |               |               |                |                |              |              |             |
| D3-1x-0053-B |      |                 |                 |                 |                 | 223<br>(8.8)    |                 |                 |                 |                 | 5.0                  |               |               |               |               |                |                |              |              |             |
| D3-1x-0076-B |      |                 |                 |                 |                 |                 |                 |                 |                 |                 | (11.0)               |               |               |               |               |                |                |              |              |             |
| D3-1x-0097-B |      |                 |                 |                 |                 |                 |                 |                 |                 |                 | 14.0 (30.9)          |               |               |               |               |                |                |              |              |             |
| D3-1x-0105-B |      |                 |                 |                 |                 |                 |                 |                 |                 |                 | 14.2 (31.3)          |               |               |               |               |                |                |              |              |             |
| D3-1x-0145-B | G2B  | 282<br>(11.1)   | 250<br>(9.8)    | 438<br>(17.2)   | 380<br>(15.0)   | 250<br>(9.8)    | n/a             | n/a             | n/a             | n/a             | 15                   |               |               |               |               |                |                |              |              |             |
| D3-1x-0170-B |      |                 |                 |                 |                 |                 |                 |                 |                 |                 | (33.1)               |               |               |               |               |                |                |              |              |             |
| D3-1x-0200-B |      |                 |                 |                 |                 |                 |                 |                 |                 |                 | 424<br>(16.7)        | 376<br>(14.8) | 440<br>(17.3) | 392<br>(15.4) | 298<br>(11.7) | n/a            | n/a            | n/a          | n/a          | 26 (57.3)   |
| D3-1x-0220-B |      |                 |                 |                 |                 |                 |                 |                 |                 |                 |                      |               |               |               |               |                |                |              |              | 29.4        |
| D3-1x-0255-B | G3B  | 424<br>(16.7)   | 376<br>(14.8)   | 440<br>(17.3)   | 392<br>(15.4)   | 298<br>(11.7)   | n/a             | n/a             | n/a             | n/a             | 64.8                 |               |               |               |               |                |                |              |              |             |
| D3-1x-0350-B |      |                 |                 |                 |                 |                 |                 |                 |                 |                 | 50.0 (110.2)         |               |               |               |               |                |                |              |              |             |
| D3-1x-0425-B | G4B  | 433<br>(17.0)   | 320<br>(12.6)   | 640<br>(25.2)   | 600<br>(23.6)   | 297<br>(11.7)   | n/a             | n/a             | n/a             | n/a             | 63.5                 |               |               |               |               |                |                |              |              |             |
| D3-1x-0500-B |      |                 |                 |                 |                 |                 |                 |                 |                 |                 | (140.0)              |               |               |               |               |                |                |              |              |             |
| D3-1x-0700-B |      |                 |                 |                 |                 |                 |                 |                 |                 |                 | 430<br>(16.9)        | 320<br>(12.6) | 689<br>(27.1) | 522<br>(20.6) | 300<br>(11.8) | 104.5<br>(4.1) | 104.5<br>(4.1) | 5.5<br>(0.2) | 8.5<br>(0.3) | 64.0        |
| D3-1x-0820-B |      |                 |                 |                 |                 |                 |                 |                 |                 |                 |                      |               |               |               |               |                |                |              |              | (141.1)     |
| D3-1x-0920-B |      |                 |                 |                 |                 |                 |                 |                 |                 |                 |                      |               |               |               |               |                |                |              |              | 23          |
| D3-1x-1000-B |      |                 |                 |                 |                 |                 |                 |                 |                 |                 |                      |               |               |               |               |                |                |              |              | (50.7)      |
| D3-1x-0255-N | G3N  | 390<br>(15.4)   | 320<br>(12.6)   | 460<br>(18.1)   | 400<br>(15.7)   | 279<br>(11.0)   | n/a             | n/a             | n/a             | n/a             | 36                   |               |               |               |               |                |                |              |              |             |
| D3-1x-0360-N |      |                 |                 |                 |                 |                 |                 |                 |                 |                 | (79.4)               |               |               |               |               |                |                |              |              |             |
| D3-1x-0430-N |      |                 |                 |                 |                 |                 |                 |                 |                 |                 | 430<br>(16.9)        | 320<br>(12.6) | 689<br>(27.1) | 522<br>(20.6) | 300<br>(11.8) | 104.5<br>(4.1) | 104.5<br>(4.1) | 5.5<br>(0.2) | 8.5<br>(0.3) | 39.5        |
| D3-1x-0650-N |      |                 |                 |                 |                 |                 |                 |                 |                 |                 |                      |               |               |               |               |                |                |              |              | (87.1)      |
| D3-1x-0790-N |      |                 |                 |                 |                 |                 |                 |                 |                 |                 | 51.5 (113.5)         |               |               |               |               |                |                |              |              |             |
| D3-1x-0930-N | G5N  | 574<br>(22.6)   | 500<br>(19.7)   | 883<br>(34.8)   | 727<br>(28.6)   | 361<br>(14.2)   | 132.5<br>(5.2)  | 129<br>(5.1)    | 5<br>(0.2)      | 8.5<br>(0.3)    | 128.5 (283.3)        |               |               |               |               |                |                |              |              |             |
| D3-16-1200-N |      |                 |                 |                 |                 |                 |                 |                 |                 |                 | 130 (286.6)          |               |               |               |               |                |                |              |              |             |
| D3-16-1410-N |      |                 |                 |                 |                 |                 |                 |                 |                 |                 | 574<br>(22.6)        | 500<br>(19.7) | 883<br>(34.8) | 727<br>(28.6) | 361<br>(14.2) | 132.5<br>(5.2) | 129<br>(5.1)   | 5<br>(0.2)   | 8.5<br>(0.3) | 140 (308.7) |
| D3-16-1600-N |      |                 |                 |                 |                 |                 |                 |                 |                 |                 |                      |               |               |               |               |                |                |              |              | 140 (308.7) |

**NOTE** Dimensions F, G and H are the additional space required for the output and input busbars, in addition to the overall chassis measurement (C).

**Figure 3-1 Unit dimensions (bypassed models)**

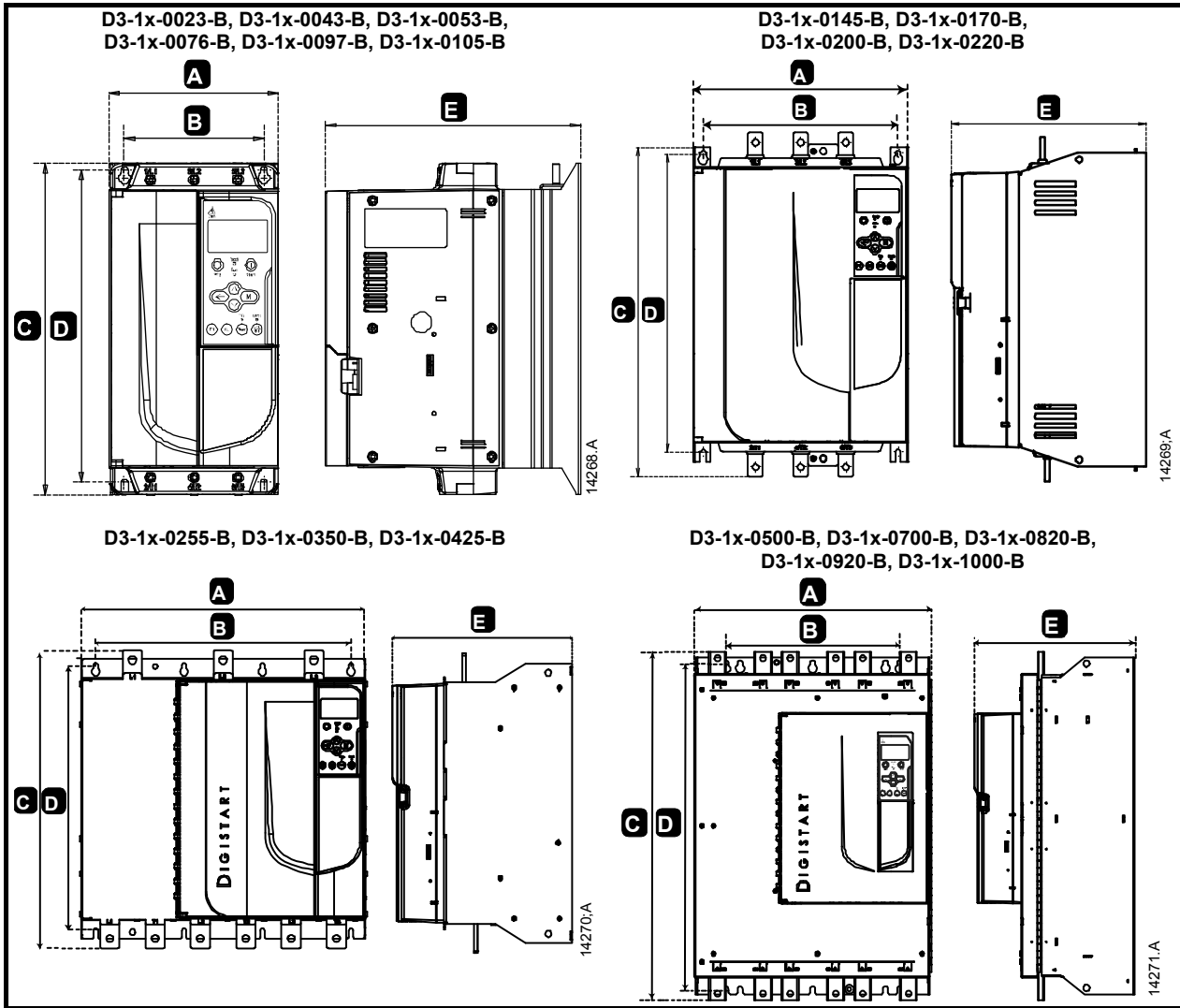
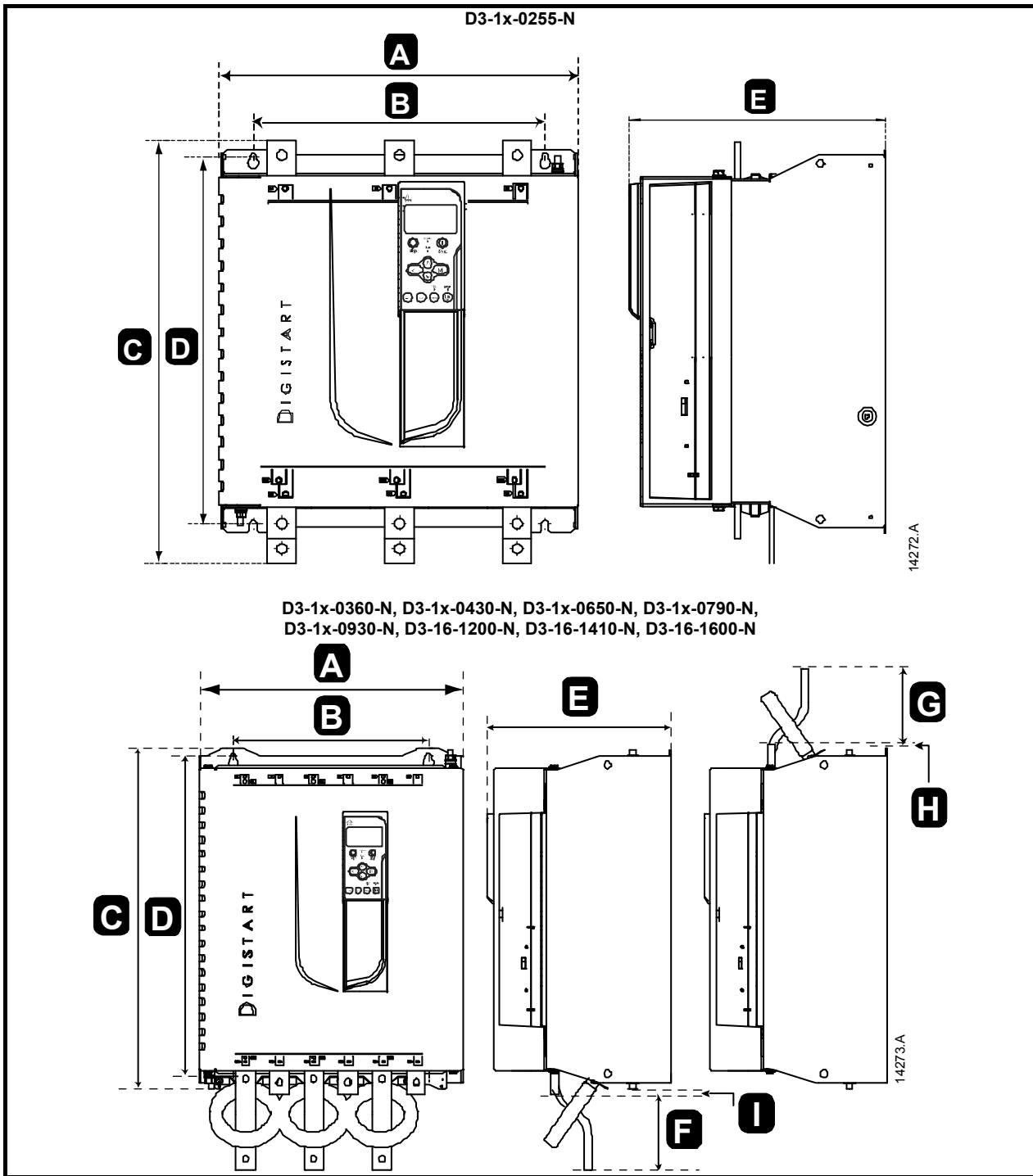
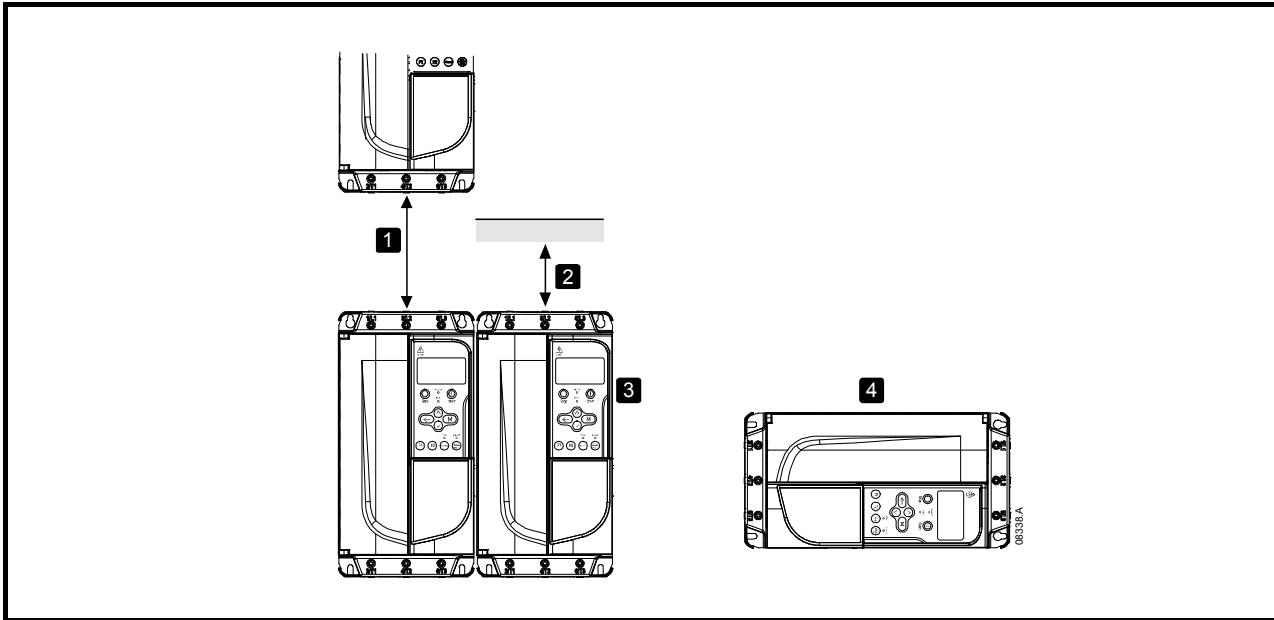

Figure 3-2 Unit dimensions (non-bypassed models)



### 3.2 Physical installation

Figure 3-3 Mounting clearances



|   |   |
|---|---|
| 1 | D3-1x-0023-B to D3-1x-0220-B: Allow 100 mm (3.94 in) between soft starters.<br>D3-1x-0255-B to D3-1x-1000-B: Allow 200 mm (7.88 in) between soft starters.<br>D3-1x-0255-N: Allow 100 mm (3.94 in) between soft starters.<br>D3-1x-0360-N to D3-16-1600-N: Allow 200 mm (7.88 in) between soft starters.  |
| 2 | D3-1x-0023-B to D3-1x-0220-B: Allow 50 mm (1.97 in) between the soft starter and solid surfaces.<br>D3-1x-0255-B to D3-1x-1000-B: Allow 200 mm (7.88 in) between the soft starter and solid surfaces.<br>D3-1x-0255-N: Allow 100 mm (3.94 in) between the soft starter and solid surfaces.<br>D3-1x-0360-N to D3-16-1600-N: Allow 200 mm (7.88 in) between the soft starter and solid surfaces. |
| 3 | Soft starters may be mounted side by side with no clearance (that is, if mounted without communications modules).   |
| 4 | The soft starter may be mounted on its side. Derate the soft starter's rated current by 15%.  |

### 3.3 Busbar adjustment procedure

The busbars on non-bypassed models D3-1x-0360-N to D3-16-1600-N can be adjusted for top or bottom input and output as required.



It is the user's responsibility to follow these instructions correctly. LEROY-SOMER cannot be held responsible for any damage to the starter or associated equipment from incorrect practice.

Figure 3-4 Busbar configuration options (D3-1x-0360-N to D3-16-1600-N)

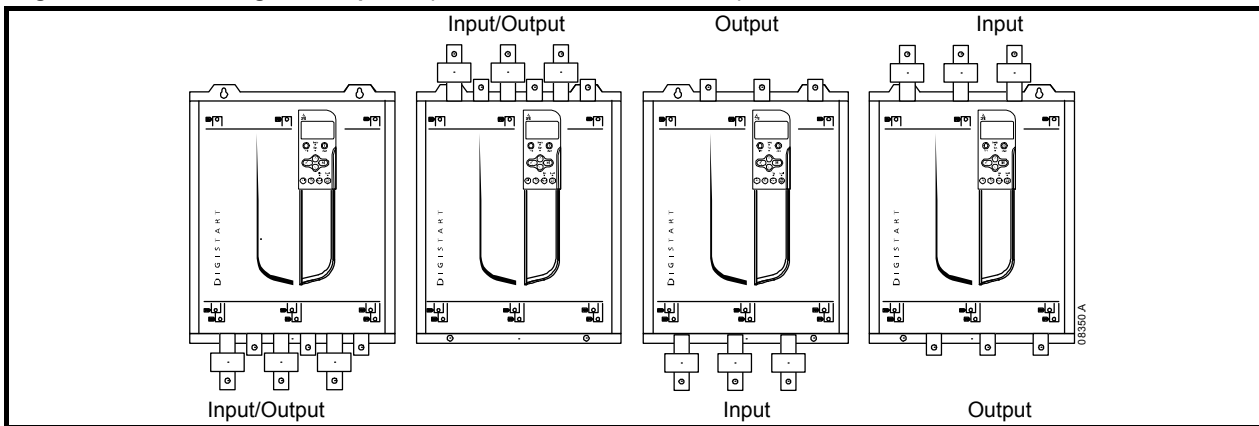

**NOTE**

Many electronic components are sensitive to static electricity. Voltages so low that they cannot be felt, seen or heard, can reduce the life, affect performance, or completely destroy sensitive electronic components. When performing service, proper ESD equipment should be used to prevent possible damage from occurring.

All units are manufactured with input and output busbars at the bottom of the unit as standard. The input and/or output busbars can be moved to the top of the unit if required.

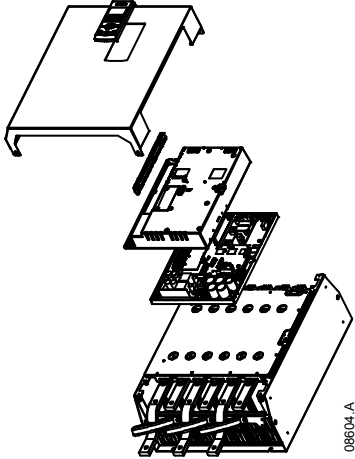

1. Remove all wiring and links from the soft starter before dismantling the unit.
2. Remove the unit cover (4 screws).
3. Remove the keypad faceplate, then gently remove the keypad (2 screws).
4. Remove the control terminal plugs.
5. Gently fold the main plastic away from the starter (12 screws).
6. Unplug the keypad loom from CON 1 (see note).
7. Label each SCR firing loom with the number of the corresponding terminal on the backplane PCB, then unplug the looms.
8. Unplug the thermistor, fan and current transformer wires from the model board.
9. Remove the plastic tray from the starter (four screws).

**NOTE**

Remove the main plastic slowly to avoid damaging the keypad wiring loom which runs between the main plastic and the backplane PCB.

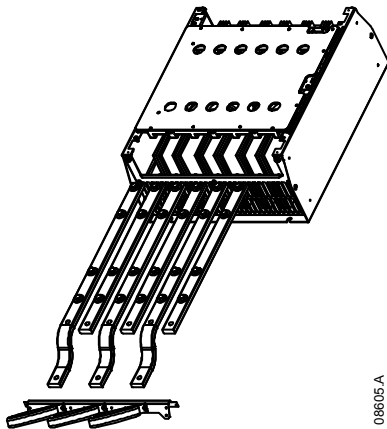

10. Unscrew and remove the magnetic bypass plates (models D3-1x-0430-N to D3-16-1600-N only).
11. Remove the current transformer assembly (three screws).
12. Identify which busbars are to be moved. Remove the bolts holding these busbars in place then slide the busbars out through the bottom of the starter (four bolts per busbar).

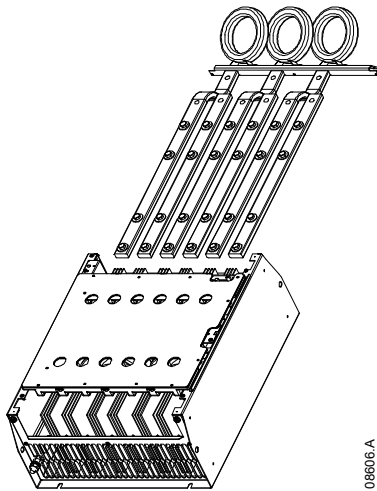

13. Slide the busbars in through the top of the starter. For input busbars, the short curved end should be outside the starter. For output busbars, the unthreaded hole should be outside the starter.
14. Replace the dome washers with the flat face towards the busbar, then tighten the bolts holding the busbars in place to 20 Nm.
15. Place the current transformer assembly over the input busbars and screw the assembly to the body of the starter (see note).
16. Run all wiring to the side of the starter and secure with cable ties.

**NOTE**

If moving the input busbars, the current transformers (CTs) must also be reconfigured.

1. Label the CTs L1, L2 and L3 (L1 is leftmost when looking from the front of the starter). Remove the cable ties and unscrew the CTs from the bracket.
2. Move the CT bracket to the top of the starter. Position the CTs for the correct phases, then screw the CTs to the bracket. For models D3-1x-0360-N to D3-1x-0930-N, the CTs must be placed on an angle (the left hand legs of each CT will be on the top row of holes and the right hand legs will be on the bottom tabs).

## 4. Electrical Installation



Always apply control voltage before (or with) mains voltage.



Always follow the specified tightening torque for all power and ground terminal connections.

For specifications and detailed technical data, see *Technical Data* on page 85.

### 4.1 Terminal layout

#### 4.1.1 Power input and output configurations

##### Internally bypassed models

Models D3-1x-0023-B to D3-1x-0220-B have power inputs at the top of the unit and outputs at the bottom of the unit.

Internally bypassed models D3-1x-0255-B to D3-1x-0425-B have output busbars at the bottom of the unit and input busbars at both the top and bottom of the unit. The AC supply can be connected 'Top in, Bottom out' or 'Bottom in, Bottom out'.

Internally bypassed models D3-1x-0500-B to D3-1x-1000-B have input and output busbars at the top and bottom of the unit. The AC supply can be connected 'Top in, Bottom out', 'Top in, Top out', 'Bottom in, Bottom out' or 'Bottom in, Top out'.

**Figure 4-1 Power input and output terminals (D3-1x-0023-B to D3-1x-1000-B)**

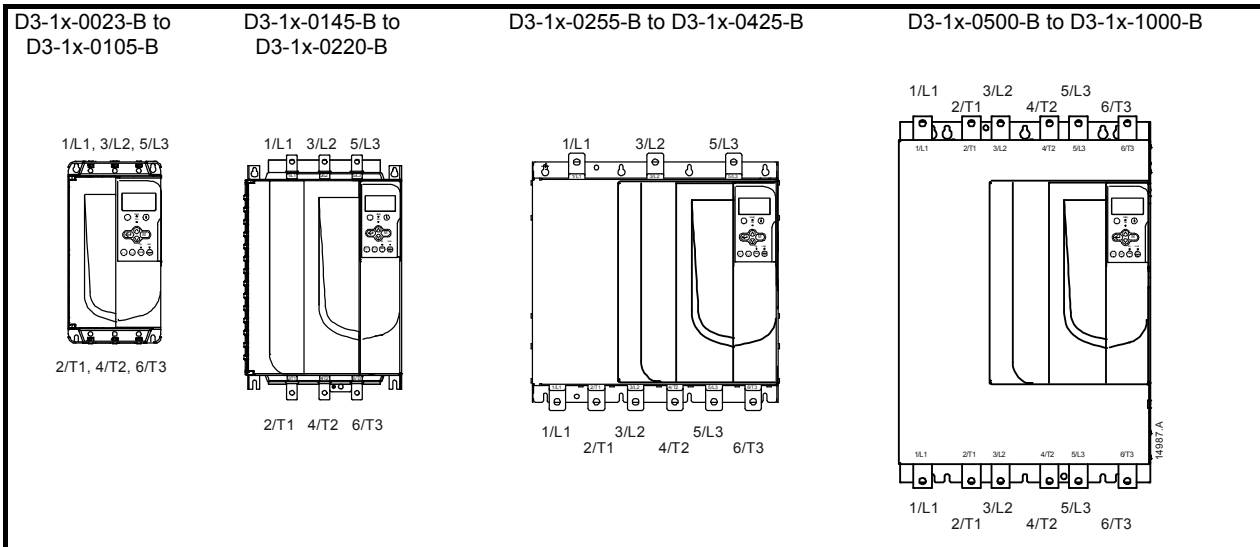

##### D3-1x-0255-N

D3-1x-0255-N has dedicated bypass terminals at the bottom of the unit. The bypass terminals are T1B, T2B, T3B.

**Figure 4-2 Power input and output terminals (D3-1x-0255-N)**

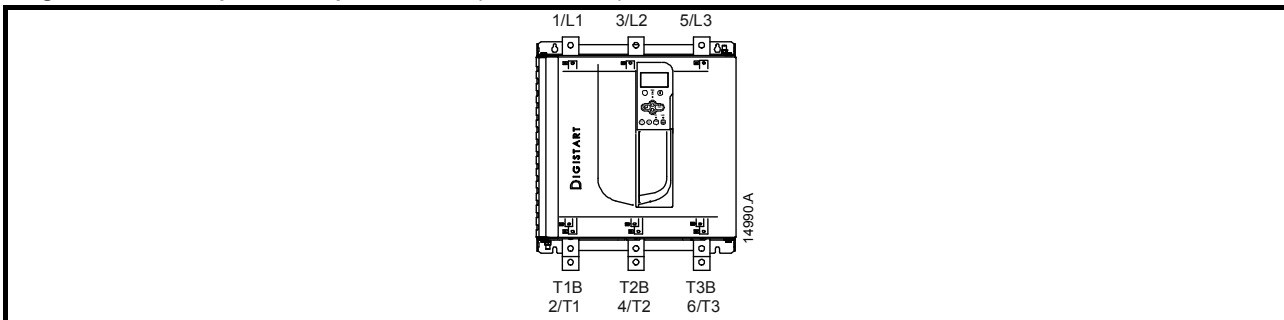

##### D3-1x-0360-N to D3-16-1600-N

D3-1x-0360-N to D3-16-1600-N have dedicated bypass terminals, on the input busbars. The bypass terminals are L1B, L2B, L3B. The busbars on non-bypassed models D3-1x-0360-N to D3-16-1600-N can be adjusted for top or bottom input and output as required. See *Busbar adjustment procedure* for step-by-step instructions. All units are manufactured top in/bottom out.

**NOTE** For models D3-1x-0360-N to D3-16-1600-N to be UL compliant, these must be mounted Top In, Bottom Out or Top Out, Bottom In. Refer to *UL Compliant Installation* on page 87 for more information.

### 4.1.2 Power terminations

Use only copper stranded or solid conductors, rated for 75 °C or higher.

**NOTE** Some units use aluminium busbars. When connecting power terminations, we recommend cleaning the surface contact area thoroughly (using an emery or stainless steel brush) and using an appropriate jointing compound to prevent corrosion.

**NOTE** For personnel safety, the power terminals on models up to D3-1x-0105-B are protected by snap-off tabs. When using large cables, it may be necessary to break off these tabs.

**Figure 4-3 Cable sizes, busbar dimensions and maximum torque settings**

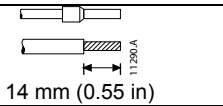
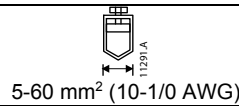
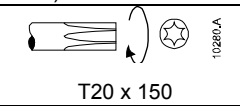
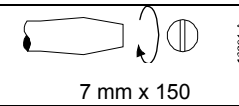
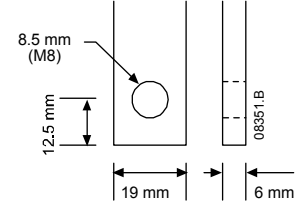
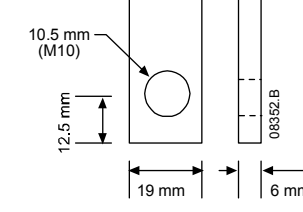
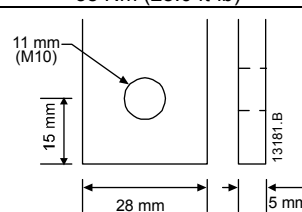
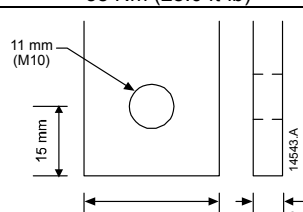
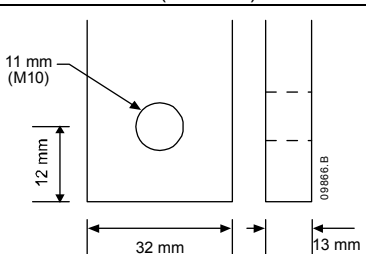
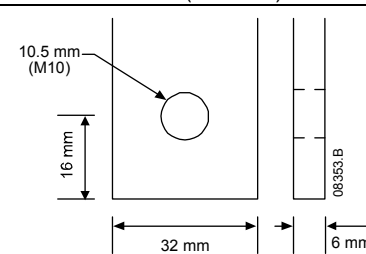
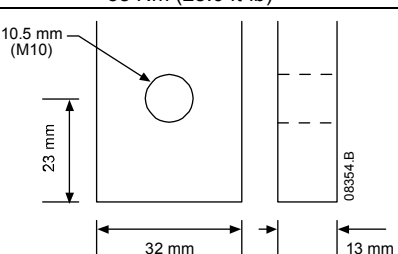
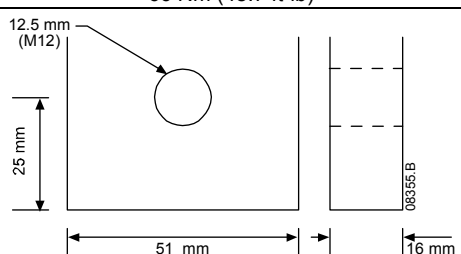
| D3-1x-0023-B to D3-1x-0105-B<br>4 Nm (2.9 ft-lb)  |  |
|---|--|
|  <p>14 mm (0.55 in)</p>  |  <p>5-60 mm<sup>2</sup> (10-1/0 AWG)</p>                              |
|  <p>T20 x 150</p>   |  <p>7 mm x 150</p>  |
| <p><b>D3-1x-0145-B</b><br/>19 Nm (14.0 ft-lb)</p>                    | <p><b>D3-1x-0170-B to D3-1x-0220-B</b><br/>38 Nm (28.0 ft-lb)</p>    |
| <p><b>D3-1x-0255-B</b><br/>38 Nm (28.0 ft-lb)</p>                   | <p><b>D3-1x-0350-B to D3-1x-0425-B</b><br/>38 Nm (28.0 ft-lb)</p>   |
| <p><b>D3-1x-0500-B to D3-1x-1000-B</b><br/>38 Nm (28.0 ft-lb)</p>  | <p><b>D3-1x-0255-N</b><br/>38 Nm (28.0 ft-lb)</p>                  |
| <p><b>D3-1x-0360-N to D3-1x-0930-N</b><br/>38 Nm (28.0 ft-lb)</p>  | <p><b>D3-16-1200-N to D3-16-1600-N</b><br/>66 Nm (48.7 ft-lb)</p>  |

### 4.1.3 Ground terminals

Ground terminals are located at the back of the soft starter.

- D3-1x-0023-B to D3-1x-0105-B have one terminal on the input side (top).
- D3-1x-0145-B to D3-1x-1000-B and D3-1x-0255-N to D3-16-1600-N have two terminals, one on the input side (top) and one on the output side (bottom).

The ground terminal may also be used for a ground shield connection if necessary.

Tighten the cables as follows:

**Table 4-1 Ground terminal maximum torque settings**

| Models                       | Terminal size | Torque |
|------------------------------|---------------|--------|
| D3-1x-0023-B to D3-1x-0105-B | M6            | 3 Nm   |
| D3-1x-0145-B to D3-1x-0255-B | M8            | 5 Nm   |
| D3-1x-0255-N                 | M8            | 5 Nm   |
| D3-1x-0350-B to D3-1x-1000-B | M10           | 8.5 Nm |
| D3-1x-0360-N to D3-16-1600-N | M10           | 8.5 Nm |

**Figure 4-4 Ground terminal locations**

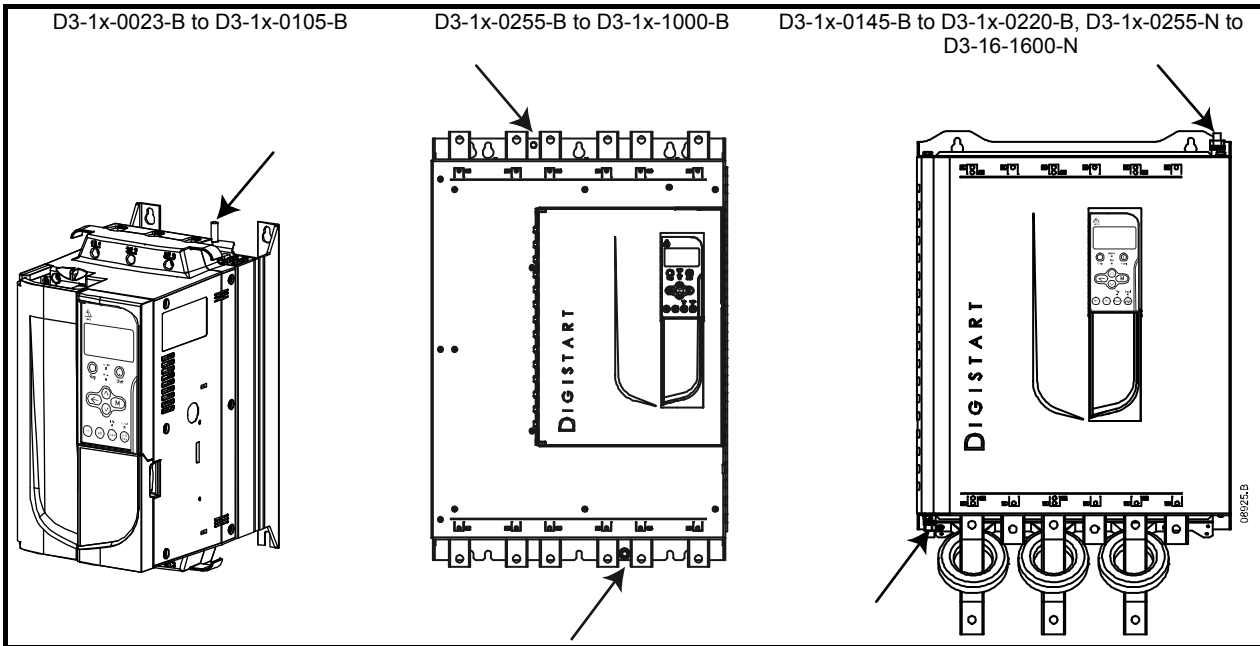

### 4.1.4 Control terminals



Always connect control voltage to the correct terminals:

- 110 to 210 Vac: CSL-CSR or
- 220 to 440 Vac: CSH-CSR



The installer must ensure that the external control circuits are insulated from human contact by at least one layer of insulation (supplementary insulation) rated for use at the AC supply voltage.

Control terminations use 2.5mm<sup>2</sup> plug-in terminal blocks. Unplug each block, complete the wiring, then reinsert the block.

**Figure 4-5 Control terminal layout**

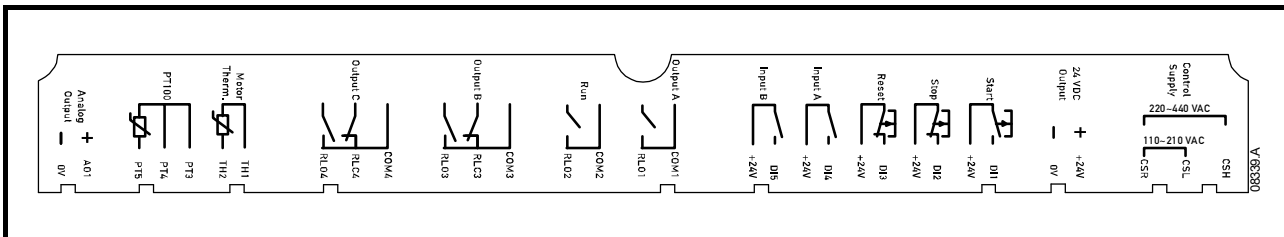

### 4.1.5 Start/stop control logic

The Digistart D3 has three fixed inputs for remote control. These inputs should be controlled by contacts rated for low voltage, low current operation (gold flash or similar).

The maximum cable run is determined by the type of cable used, provided the maximum resistance of this cable does not exceed 100 Ohms. The cables must be twisted in pairs and shielded. The shield must be grounded at one end only, that is, at the soft starter end. To avoid any EMC disturbance from the motor power cables, the thermistor cable must be separated from the motor power cables by a minimum parallel distance of 300 mm.

**Figure 4-6 Control wiring options**

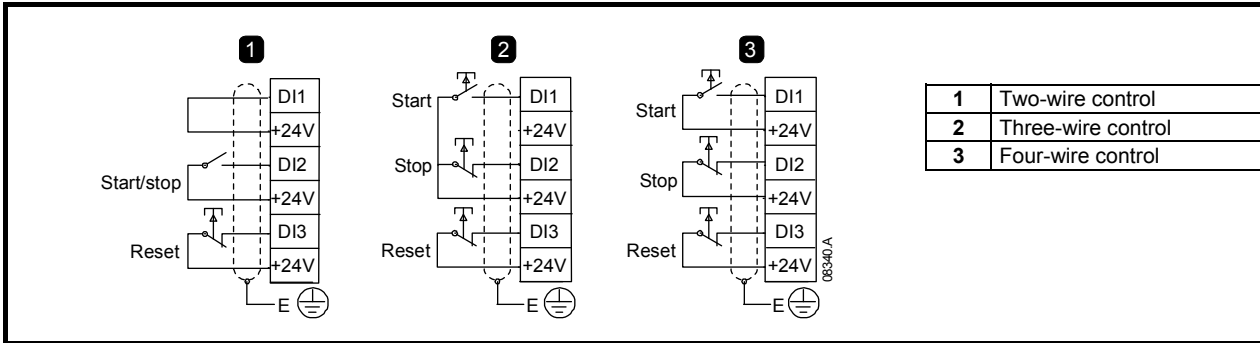

**NOTE** For comprehensive information on control connection, see *Control connections* on page 21.



Do not apply voltage to the control input terminals. These are active 24 Vdc inputs and must be controlled with potential free contacts.

Cables to the control inputs must be segregated from mains voltage and motor cabling.

**NOTE** You can set the Reset input to either NO or NC (default). See Pr **3N Remote Reset Logic**.

### 4.1.6 Relay outputs

The Digistart D3 provides four relay outputs, one fixed and three programmable.

The Run output closes when the soft start is complete (when the starting current falls below 120% of the programmed motor full load current) and remains closed until the beginning of a stop (either soft stop or coast to stop).

Operation of the programmable outputs is determined by the settings of Pr **4A** to **4I**.

- If assigned to Main Contactor, the output activates as soon as the soft starter receives a start command and remains active while the soft starter is controlling the motor (until the motor starts a coast to stop, or until the end of a soft stop).
- If assigned to a trip function, the output activates when a trip occurs.
- If assigned to a flag, the output activates when the specified flag is active (Pr **7A** to **7C**).



Some electronic contactor coils are not suitable for direct switching with PCB mount relays. Consult the contactor manufacturer/supplier to confirm suitability.

Three additional outputs are available on the input/output expansion card.

### 4.1.7 Motor thermistors

Motor thermistors can be connected directly to the Digistart D3. The soft starter will trip when the resistance of the thermistor circuit exceeds approximately 3.6 k $\Omega$  or falls below 20  $\Omega$ .

**Figure 4-7 Motor thermistor connection**

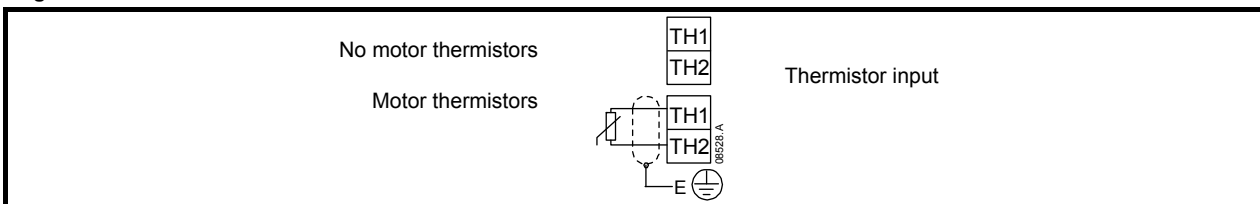

**NOTE** If no motor thermistors are connected to the Digistart D3 thermistor input terminals TH1, TH2 must be open. If TH1, TH2 are shorted, the Digistart D3 will trip. The thermistor circuit should be run in screened cable and must be electrically isolated from ground and all other power and control circuits.

### 4.1.8 Programmable inputs

The default setting of programmable input A is 'Starter Disable' (Pr 3A). **If the Starter Disable function is not required, change the setting of Pr 3A or connect a link across DI4, +24V.**

If programmable input A is set to 'Starter Disable', the circuit must be closed for the starter to operate. An open circuit across DI4, +24V will disable the starter. The Digistart D3 will not respond to start commands. If running, the soft starter will allow the motor to coast to stop, ignoring the soft stop mode set in Pr 2H.

## 4.2 Control connections

Figure 4-8 Digistart D3 electrical schematic

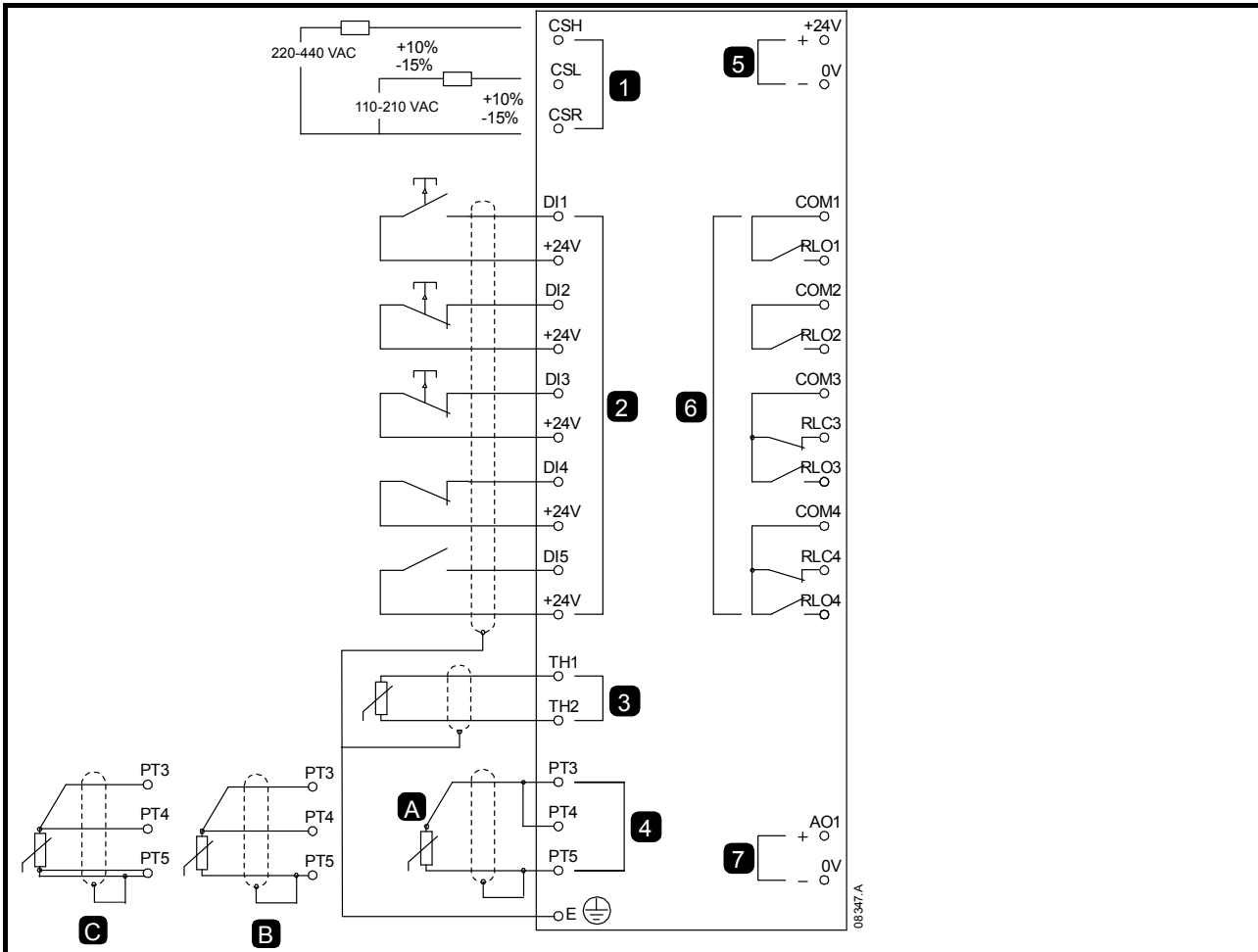

|    |                          |
|----|--------------------------|
| 1  | Control voltage          |
| 2  | Remote control inputs    |
| 3  | Motor thermistor input   |
| 4A | RTD/PT100 input - 2-wire |
| 4B | RTD/PT100 input - 3-wire |
| 4C | RTD/PT100 input - 4-wire |
| 5  | 24 Vdc output            |
| 6  | Relay outputs            |
| 7  | Analog output            |

|                  |                      |
|------------------|----------------------|
| DI1, +24V        | Start                |
| DI2, +24V        | Stop                 |
| DI3, +24V        | Reset                |
| DI4, +24V        | Programmable input A |
| DI5, +24V        | Programmable input B |
| COM1, RLO1       | Relay output A       |
| COM2, RLO2       | Run relay output     |
| COM3, RLC3, RLO3 | Relay output B       |
| COM4, RLC4, RLO4 | Relay output C       |

The Digistart D3 can be disabled via the control inputs. An open circuit across DI4, +24V will disable the starter. The Digistart D3 will not respond to start commands. If running, the soft starter will allow the motor to coast to stop, ignoring the soft stop mode set in Pr 2H.

To use the starter disable function, set Pr 3A to 'Starter Disable' (this is the default setting).

**If the Starter Disable function is not required, change the setting of Pr 3A or connect a link across DI4, +24V.**

For keypad control, the soft starter requires:

- control supply connections (terminals CSH, CSL, CSR depending on the control voltage)
- programmable input A (DI4, +24V) must be closed or Pr 3A *Input A Function* must be changed (the default setting is Starter Disable)

## 4.3 Power connections

### 4.3.1 Motor connection

Digistart D3 soft starters can be connected to the motor in-line or inside delta (also called three-wire and six-wire connection). When connecting in inside delta, enter the motor full load current (FLC) for Pr **1A**. The Digistart D3 will automatically detect whether the motor is connected in-line or inside delta and will calculate the correct inside delta current level.

**NOTE** For personnel safety, the power terminals on models up to D3-1x-0105-B are protected by snap-off tabs. When using large cables, it may be necessary to break off these tabs.

Models which are internally bypassed do not require an external bypass contactor.

Internally bypassed models:

D3-1x-0023-B, D3-1x-0043-B, D3-1x-0053-B, D3-1x-0076-B, D3-1x-0097-B, D3-1x-0105-B, D3-1x-0145-B, D3-1x-0170-B, D3-1x-0200-B, D3-1x-0220-B, D3-1x-0255-B, D3-1x-0350-B, D3-1x-0425-B, D3-1x-0500-B, D3-1x-0700-B, D3-1x-0820-B, D3-1x-0920-B, D3-1x-1000-B

Non-bypassed models:

D3-1x-0255-N, D3-1x-0360-N, D3-1x-0430-N, D3-1x-0650-N, D3-1x-0790-N, D3-1x-0930-N, D3-16-1200-N, D3-16-1410-N, D3-16-1600-N

### 4.3.2 In-line installation

- In-line installation, internally bypassed

**Figure 4-9 Power connections - in-line installation, internally bypassed**

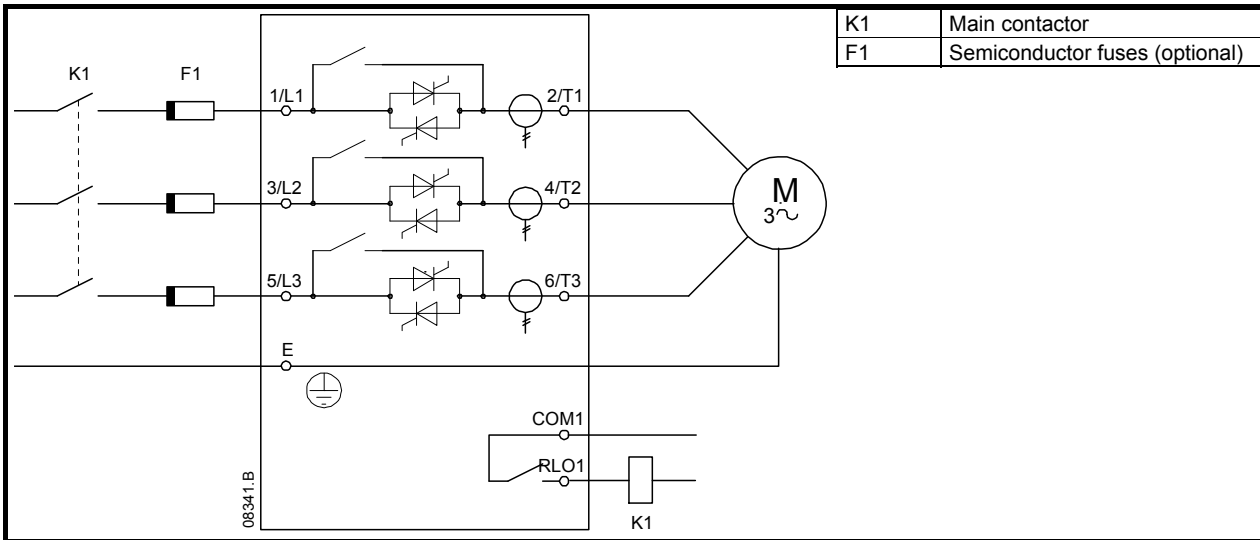

**NOTE** Main contactor is the default setting for Pr **4A Relay A Action** (COM1, RLO1).

- In-line installation, externally bypassed

Non-bypassed models have dedicated bypass terminals, which allow the Digistart D3 to continue providing protection and monitoring functions even when bypassed via an external bypass contactor. The bypass contactor must be connected to the bypass terminals and controlled by the soft starter's run output (terminals COM2, RLO2).

**Figure 4-10 Power connections - in-line installation, externally bypassed (D3-1x-0255-N)**

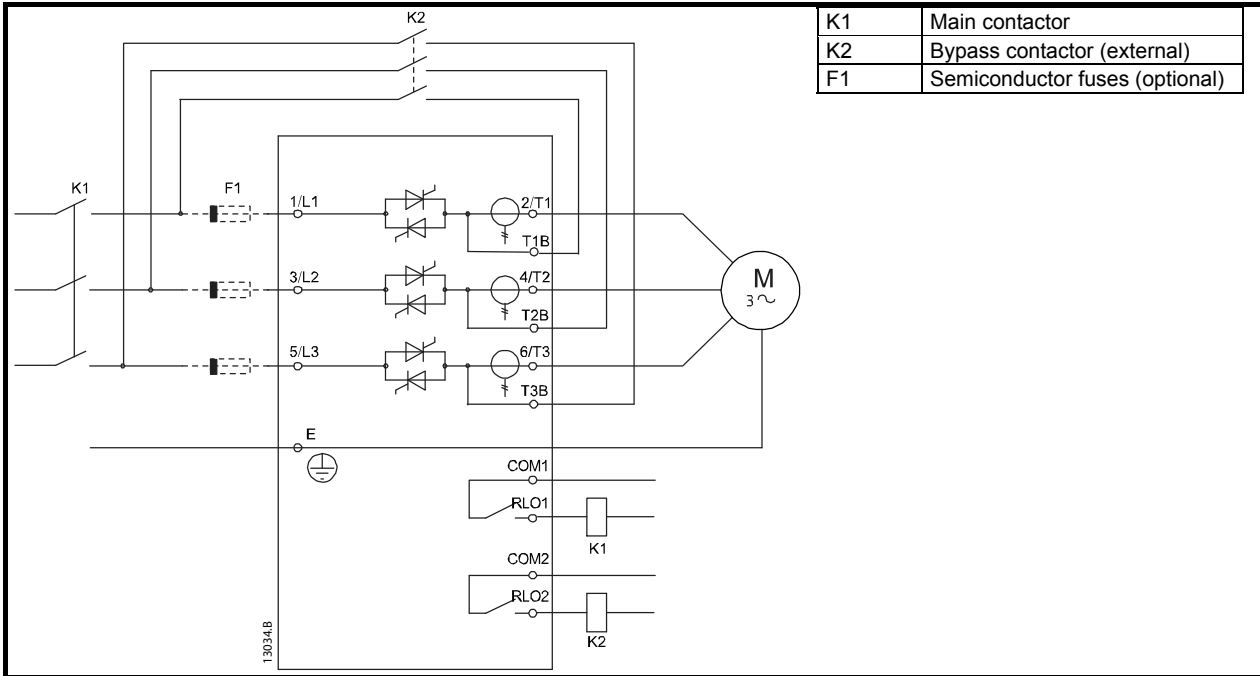

**Figure 4-11 Power connections - in-line installation, externally bypassed (D3-1x-0360-N to D3-16-1600-N)**

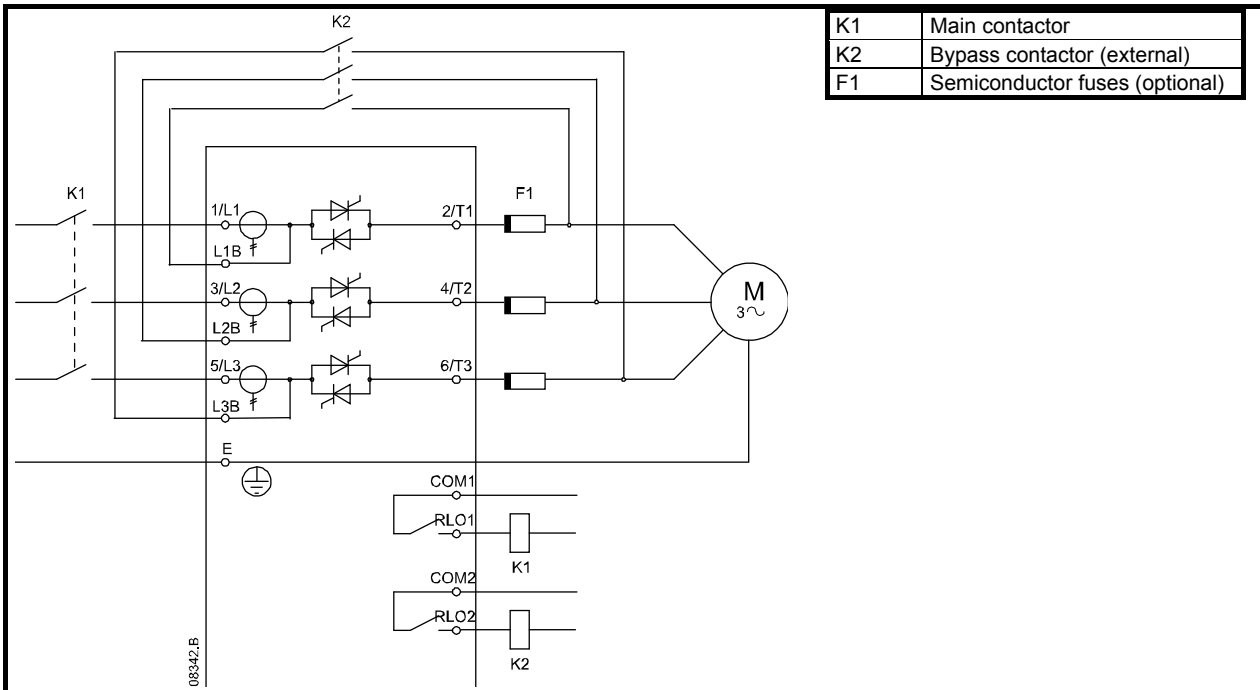

**NOTE** The bypass terminals on D3-1x-0255-N are T1B, T2B, T3B. The bypass terminals on D3-1x-0360-N to D3-16-1600-N are L1B, L2B, L3B.

The fuses can be installed on the input side if required.

**NOTE** Main contactor is the default setting for Pr **4A Relay A Action** (COM1, RLO1). Output relay COM2, RLO2 is dedicated to Run output operation and is ideal for managing an external bypass contactor.

- In-line installation, non-bypassed

**Figure 4-12 Power connections - in-line installation, non-bypassed**

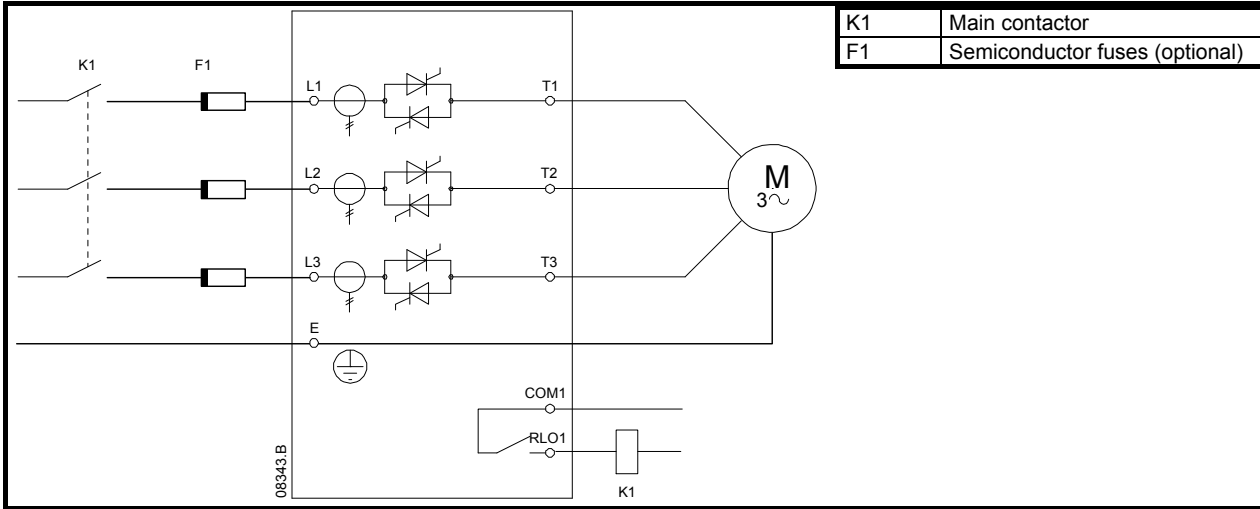

### 4.3.3 Inside delta installation



When connecting the Digistart D3 in inside delta configuration, always install a main contactor or shunt trip circuit breaker.

**NOTE** When connecting in inside delta, enter the motor full load current (FLC) for Pr **1A**. The Digistart D3 will automatically detect whether the motor is connected in-line or inside delta and will calculate the correct inside delta current level.

- Inside delta installation, internally bypassed

**Figure 4-13 Power connections - inside delta installation, internally bypassed**

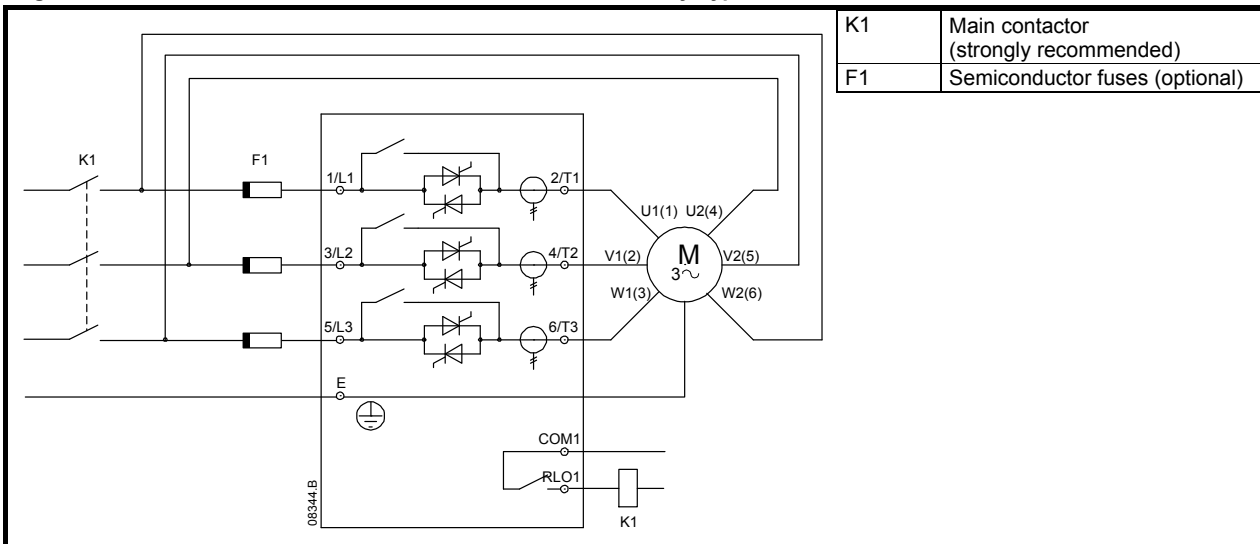

- Inside delta installation, externally bypassed

Non-bypassed models have dedicated bypass terminals, which allow the Digistart D3 to continue providing protection and monitoring functions even when bypassed via an external bypass contactor. The bypass contactor must be connected to the bypass terminals and controlled by the soft starter's run output (terminals COM2, RLO2).

**Figure 4-14 Power connections - inside delta installation, externally bypassed (D3-1x-0255-N)**

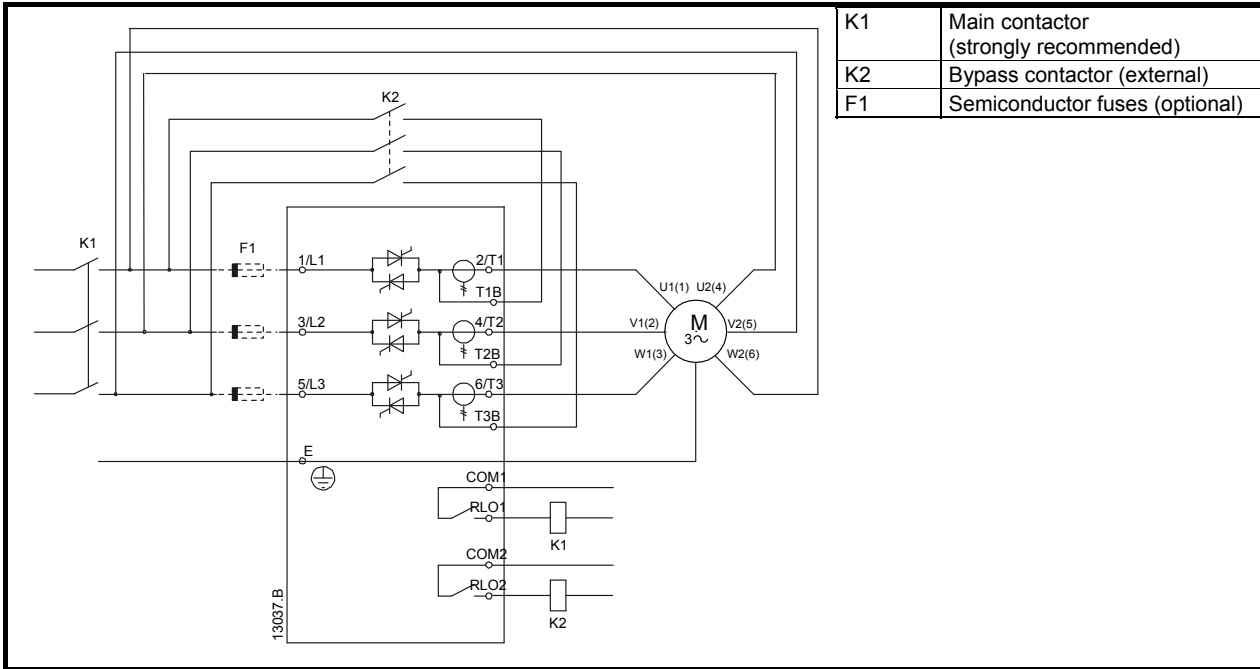

**Figure 4-15 Power connections - inside delta installation, externally bypassed (D3-1x-0360-N to D3-16-1600-N)**

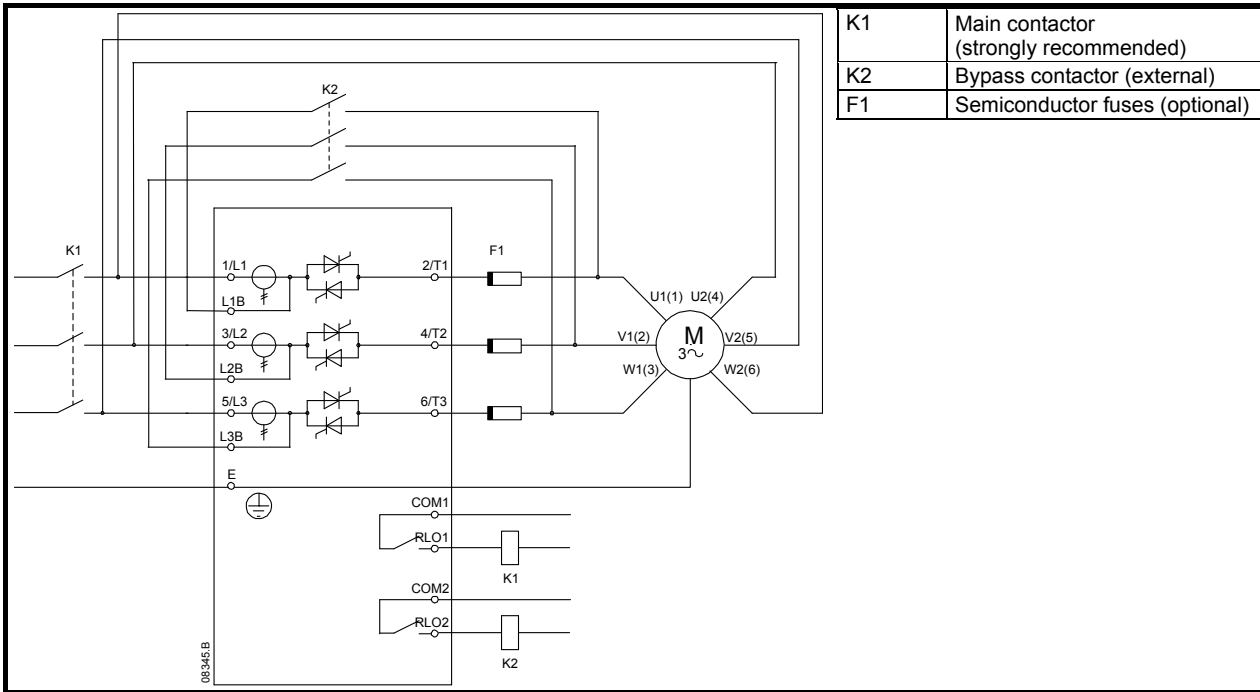

**NOTE** The bypass terminals on D3-1x-0255-N are T1B, T2B, T3B. The bypass terminals on D3-1x-0360-N to D3-16-1600-N are L1B, L2B, L3B.

The fuses can be installed on the input side if required.

- Inside delta installation, non-bypassed

**Figure 4-16 Power connections - inside delta installation, non-bypassed**

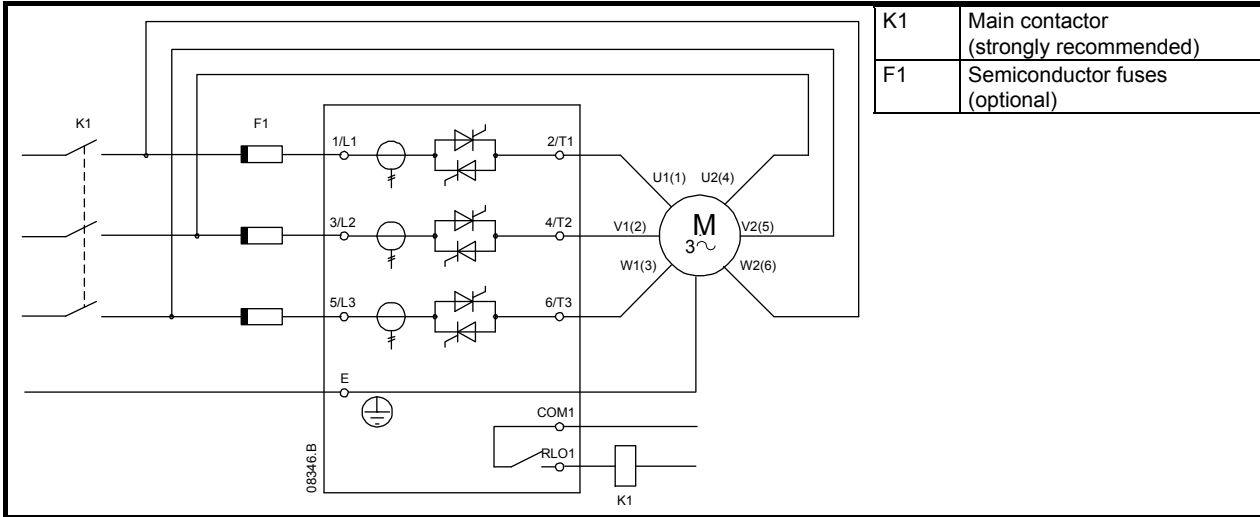

## 4.4 Fuse information

### 4.4.1 Power supply fuses

Semiconductor fuses can be used for Type 2 coordination (according to IEC 60947-4-2 standard) and to reduce the risk of damage to SCRs from transient overload currents.

HRC fuses (such as Ferraz/Mersen AJT fuses) can be used for Type 1 coordination according to IEC 60947-4-2 standard.

**NOTE** Fuses are not delivered with Digistart D3 soft starters.



Adaptive Control controls the motor's speed profile, within the programmed time limit. This may result in a higher level of current than traditional control methods.

For applications using Adaptive Control to soft stop the motor with stop times greater than 30 seconds, motor branch protection should be selected as follows:

- standard HRC line fuses: minimum 150% motor full load current
- motor rated line fuses: minimum rating 100/150% motor full load current
- motor control circuit breaker minimum long time setting: 150% motor full load current
- motor control circuit breaker minimum short time setting: 400% motor full load current for 30 seconds

**NOTE** Fuse selection is based on a 400% FLC start for 20 seconds in conjunction with standard published starts per hour, duty cycle, 40°C ambient temperature and up to 1000 m altitude. For installations operating outside these conditions, consult your local supplier.

These fuse tables contain recommendations only. Always consult your local supplier to confirm the selection for your particular application.

**Table 4-2 Bussman fuses - square body (170M)**

| Model        | SCR I <sup>2</sup> T (A <sup>2</sup> S) | Supply Voltage (≤ 440 Vac) | Supply Voltage (≤ 575 Vac) | Supply Voltage (≤ 690 Vac) |
|--------------|---|----------------------------|----------------------------|----------------------------|
| D3-1x-0023-B | 1150                                    | 170M1314                   | 170M1314                   | 170M1314                   |
| D3-1x-0043-B | 8000                                    | 170M1316                   | 170M1316                   | 170M1316                   |
| D3-1x-0053-B | 15000                                   | 170M1318                   | 170M1318                   | 170M1318                   |
| D3-1x-0076-B | 15000                                   | 170M1319                   | 170M1319                   | 170M1318                   |
| D3-1x-0097-B | 51200                                   | 170M1321                   | 170M1321                   | 170M1319                   |
| D3-1x-0105-B | 125000                                  | 170M1321                   | 170M1321                   | 170M1321                   |
| D3-1x-0145-B | 125000                                  | 170M1321                   | 170M1321                   | 170M1321                   |
| D3-1x-0170-B | 320000                                  | 170M2621                   | 170M2621                   | 170M2621                   |
| D3-1x-0200-B | 320000                                  | 170M2621                   | 170M2621                   | 170M2621                   |
| D3-1x-0220-B | 320000                                  | 170M2621                   | 170M2621                   | 170M2621                   |
| D3-1x-0255-B | 320000                                  | 170M2621                   | 170M2621                   | 170M2621                   |
| D3-1x-0350-B | 202000                                  | 170M5011                   | 170M5011                   | —                          |
| D3-1x-0425-B | 320000                                  | 170M6011                   | —                          | —                          |
| D3-1x-0500-B | 320000                                  | 170M6008*                  | —                          | —                          |
| D3-1x-0700-B | 781000                                  | 170M5015                   | 170M5015                   | —                          |
| D3-1x-0820-B | 1200000                                 | 170M5017                   | 170M6015                   | —                          |
| D3-1x-0920-B | 2530000                                 | 170M6017                   | 170M6017                   | —                          |
| D3-1x-1000-B | 2530000                                 | 170M6018                   | 170M6013*                  | —                          |
| D3-1x-0255-N | 320000                                  | 170M2621                   | 170M2621                   | 170M2621                   |
| D3-1x-0360-N | 320000                                  | 170M6010                   | 170M6010                   | 170M6010                   |
| D3-1x-0430-N | 320000                                  | 170M6011                   | 170M6011                   | —                          |
| D3-1x-0650-N | 1200000                                 | 170M6015                   | 170M6015                   | 170M6014                   |
| D3-1x-0790-N | 2530000                                 | 170M6017                   | 170M6017                   | 170M6016                   |
| D3-1x-0930-N | 4500000                                 | 170M6019                   | 170M6019                   | 170M6019                   |
| D3-16-1200-N | 4500000                                 | 170M6021                   | —                          | —                          |
| D3-16-1410-N | 6480000                                 | —                          | —                          | —                          |
| D3-16-1600-N | 12500000                                | 170M6019*                  | —                          | —                          |

\* Two parallel connected fuses required per phase.

**Table 4-3 Bussman fuses - British style (BS88)**

| Model        | SCR I <sup>2</sup> T (A <sup>2</sup> S) | Supply Voltage (≤ 440 Vac) | Supply Voltage (≤ 575 Vac) | Supply Voltage (≤ 690 Vac) |
|--------------|---|----------------------------|----------------------------|----------------------------|
| D3-1x-0023-B | 1150                                    | 63FE                       | 63FE                       | 63FE                       |
| D3-1x-0043-B | 8000                                    | 120FEE                     | 120FEE                     | 120FEE                     |
| D3-1x-0053-B | 15000                                   | 200FEE                     | 200FEE                     | 200FEE                     |
| D3-1x-0076-B | 15000                                   | 200FEE                     | 200FEE                     | 200FEE                     |
| D3-1x-0097-B | 51200                                   | 200FEE                     | 200FEE                     | 200FEE                     |
| D3-1x-0105-B | 125000                                  | 280FM                      | 280FM                      | 280FM                      |
| D3-1x-0145-B | 125000                                  | 280FM                      | 280FM                      | 280FM                      |
| D3-1x-0170-B | 320000                                  | 450FMM                     | 450FMM                     | 450FMM                     |
| D3-1x-0200-B | 320000                                  | 450FMM                     | 450FMM                     | 450FMM                     |
| D3-1x-0220-B | 320000                                  | 450FMM                     | 450FMM                     | 450FMM                     |
| D3-1x-0255-B | 320000                                  | 450FMM                     | 450FMM                     | 450FMM                     |
| D3-1x-0350-B | 202000                                  | 315FM*                     | —                          | —                          |
| D3-1x-0425-B | 320000                                  | 400FMM*                    | —                          | —                          |
| D3-1x-0500-B | 320000                                  | 450FMM*                    | —                          | —                          |
| D3-1x-0700-B | 781000                                  | 630FMM*                    | —                          | —                          |
| D3-1x-0820-B | 1200000                                 | —                          | —                          | —                          |
| D3-1x-0920-B | 2530000                                 | —                          | —                          | —                          |
| D3-1x-1000-B | 2530000                                 | —                          | —                          | —                          |
| D3-1x-0255-N | 320000                                  | 450FMM                     | 450FMM                     | 450FMM                     |
| D3-1x-0360-N | 320000                                  | —                          | —                          | —                          |
| D3-1x-0430-N | 320000                                  | —                          | —                          | —                          |
| D3-1x-0650-N | 1200000                                 | 630FMM*                    | 630FMM*                    | —                          |
| D3-1x-0790-N | 2530000                                 | —                          | —                          | —                          |
| D3-1x-0930-N | 4500000                                 | —                          | —                          | —                          |
| D3-16-1200-N | 4500000                                 | —                          | —                          | —                          |
| D3-16-1410-N | 6480000                                 | —                          | —                          | —                          |
| D3-16-1600-N | 12500000                                | —                          | —                          | —                          |

\* Two parallel connected fuses required per phase.

**Table 4-4 Ferraz/Mersen fuses - HSJ**

| Model        | SCR I <sup>2</sup> T (A <sup>2</sup> S) | Supply Voltage (≤ 440 Vac) | Supply Voltage (≤ 575 Vac) | Supply Voltage (≤ 690 Vac) |              |              |
|--------------|---|----------------------------|----------------------------|----------------------------|--------------|--------------|
| D3-1x-0023-B | 1150                                    | HSJ40**                    | HSJ40**                    | Not suitable               |              |              |
| D3-1x-0043-B | 8000                                    | HSJ80**                    | HSJ80**                    |                            |              |              |
| D3-1x-0053-B | 15000                                   | HSJ110**                   | HSJ110**                   |                            |              |              |
| D3-1x-0076-B | 15000                                   | HSJ125**                   | HSJ125**                   |                            |              |              |
| D3-1x-0097-B | 51200                                   | HSJ175                     | HSJ175**                   |                            |              |              |
| D3-1x-0105-B | 125000                                  | HSJ225                     | HSJ225                     |                            |              |              |
| D3-1x-0145-B | 125000                                  | HSJ250                     | HSJ250**                   |                            |              |              |
| D3-1x-0170-B | 320000                                  | HSJ300                     | HSJ300                     |                            |              |              |
| D3-1x-0200-B | 320000                                  | HSJ350                     | HSJ350                     |                            |              |              |
| D3-1x-0220-B | 320000                                  | HSJ400**                   | HSJ400**                   |                            |              |              |
| D3-1x-0255-B | 320000                                  | HSJ450*                    | HSJ450**                   |                            |              |              |
| D3-1x-0350-B | 202000                                  | HSJ500**                   | Not suitable               |                            |              |              |
| D3-1x-0425-B | 320000                                  | Not suitable               |                            |                            | Not suitable |              |
| D3-1x-0500-B | 320000                                  |                            |                            |                            |              |              |
| D3-1x-0700-B | 781000                                  |                            |                            |                            |              |              |
| D3-1x-0820-B | 1200000                                 |                            |                            |                            |              |              |
| D3-1x-0920-B | 2530000                                 |                            |                            |                            |              |              |
| D3-1x-1000-B | 2530000                                 |                            |                            |                            |              |              |
| D3-1x-0255-N | 320000                                  |                            |                            |                            |              | HSJ450**     |
| D3-1x-0360-N | 320000                                  |                            | Not suitable               |                            |              | Not suitable |
| D3-1x-0430-N | 320000                                  |                            |                            |                            |              |              |
| D3-1x-0650-N | 1200000                                 |                            |                            |                            |              |              |
| D3-1x-0790-N | 2530000                                 |                            |                            |                            |              |              |
| D3-1x-0930-N | 4500000                                 |                            |                            |                            |              |              |
| D3-16-1200-N | 4500000                                 |                            |                            |                            |              |              |
| D3-16-1410-N | 6480000                                 |                            |                            |                            |              |              |
| D3-16-1600-N | 12500000                                |                            |                            |                            |              |              |

\*\* Two series connected fuses required per phase.

|                    |             |                         |                         |                   |                           |           |             |             |                      |                |             |         |
|--------------------|-------------|-------------------------|-------------------------|-------------------|---------------------------|-----------|-------------|-------------|----------------------|----------------|-------------|---------|
| Safety Information | Rating Data | Mechanical Installation | Electrical Installation | Keypad and Status | Quick Start Commissioning | Operation | Programming | Diagnostics | Application Examples | Technical Data | Maintenance | Options |
|--------------------|-------------|-------------------------|-------------------------|-------------------|---------------------------|-----------|-------------|-------------|----------------------|----------------|-------------|---------|

**Table 4-5 Ferraz/Mersen fuses - North American style (PSC 690)**

| Model        | SCR I <sup>2</sup> T (A <sup>2</sup> S) | Supply Voltage (≤ 440 Vac) | Supply Voltage (≤ 575 Vac) | Supply Voltage (≤ 690 Vac) |
|--------------|---|----------------------------|----------------------------|----------------------------|
| D3-1x-0023-B | 1150                                    | A070URD30XXX0063           | A070URD30XXX0063           | —                          |
| D3-1x-0043-B | 8000                                    | A070URD30XXX0125           | A070URD30XXX0125           | A070URD30XXX0125           |
| D3-1x-0053-B | 15000                                   | A070URD30XXX0125           | A070URD30XXX0125           | A070URD30XXX0125           |
| D3-1x-0076-B | 15000                                   | A070URD30XXX0160           | A070URD30XXX0160           | A070URD30XXX0160           |
| D3-1x-0097-B | 51200                                   | A070URD30XXX0200           | A070URD30XXX0200           | A070URD30XXX0200           |
| D3-1x-0105-B | 125000                                  | A070URD30XXX0315           | A070URD30XXX0315           | A070URD30XXX0315           |
| D3-1x-0145-B | 125000                                  | A070URD30XXX0315           | A070URD30XXX0315           | A070URD30XXX0315           |
| D3-1x-0170-B | 320000                                  | A070URD30XXX0315           | A070URD30XXX0315           | A070URD30XXX0315           |
| D3-1x-0200-B | 320000                                  | A070URD30XXX0450           | A070URD30XXX0450           | A070URD30XXX0450           |
| D3-1x-0220-B | 320000                                  | A070URD30XXX0450           | A070URD30XXX0450           | A070URD30XXX0450           |
| D3-1x-0255-B | 320000                                  | A070URD30XXX0450           | A070URD30XXX0450           | A070URD30XXX0450           |
| D3-1x-0350-B | 202000                                  | A070URD31XXX0550           | —                          | —                          |
| D3-1x-0425-B | 320000                                  | A070URD32XXX0630           | —                          | —                          |
| D3-1x-0500-B | 320000                                  | A070URD32XXX0700           | —                          | —                          |
| D3-1x-0700-B | 781000                                  | A070URD33XXX0900           | —                          | —                          |
| D3-1x-1000-B | 2530000                                 | A070URD33XXX1400           | —                          | —                          |
| D3-1x-0255-N | 320000                                  | A070URD30XXX0450           | A070URD30XXX0450           | A070URD30XXX0450           |
| D3-1x-0360-N | 320000                                  | A070URD33XXX0630           | A070URD33XXX0630           | A070URD33XXX0630           |
| D3-1x-0430-N | 320000                                  | A070URD33XXX0700           | A070URD33XXX0700           | —                          |
| D3-1x-0650-N | 1200000                                 | A070URD33XXX1000           | A070URD33XXX1000           | A070URD33XXX1000           |
| D3-1x-0790-N | 2530000                                 | A070URD33XXX1400           | A070URD33XXX1400           | A070URD33XXX1250           |
| D3-1x-0930-N | 4500000                                 | A070URD33XXX1400           | A070URD33XXX1400           | A070URD33XXX1400           |
| D3-16-1200-N | 4500000                                 | A055URD33XXX2250           | —                          | —                          |
| D3-16-1410-N | 6480000                                 | A055URD33XXX2250           | —                          | —                          |
| D3-16-1600-N | 12500000                                | —                          | —                          | —                          |

XXX = blade type. See Ferraz/Mersen catalog for details.

**Table 4-6 Ferraz/Mersen fuses - European style (PSC 690)**

| Model        | SCR I <sup>2</sup> T (A <sup>2</sup> S) | Supply Voltage (≤ 440 Vac) | Supply Voltage (≤ 575 Vac) | Supply Voltage (≤ 690 Vac) |
|--------------|---|----------------------------|----------------------------|----------------------------|
| D3-1x-0023-B | 1150                                    | 6.9URD30XXXX0050           | 6.9URD30XXXX0050           | 6.9URD30XXXX0050           |
| D3-1x-0043-B | 8000                                    | 6.9URD30XXXX0125           | 6.9URD30XXXX0125           | 6.9URD30XXXX0125           |
| D3-1x-0053-B | 15000                                   | 6.9URD30XXXX0125           | 6.9URD30XXXX0125           | 6.9URD30XXXX0125           |
| D3-1x-0076-B | 15000                                   | 6.9URD30XXXX0160           | 6.9URD30XXXX0160           | 6.9URD30XXXX0160           |
| D3-1x-0097-B | 51200                                   | 6.9URD30XXXX0200           | 6.9URD30XXXX0200           | 6.9URD30XXXX0200           |
| D3-1x-0105-B | 125000                                  | 6.9URD30XXXX0315           | 6.9URD30XXXX0315           | 6.9URD30XXXX0315           |
| D3-1x-0145-B | 125000                                  | 6.9URD30XXXX0315           | 6.9URD30XXXX0315           | 6.9URD30XXXX0315           |
| D3-1x-0170-B | 320000                                  | 6.9URD30XXXX0315           | 6.9URD30XXXX0315           | 6.9URD30XXXX0315           |
| D3-1x-0200-B | 320000                                  | 6.9URD31XXXX0450           | 6.9URD31XXXX0450           | 6.9URD31XXXX0450           |
| D3-1x-0220-B | 320000                                  | 6.9URD31XXXX0450           | 6.9URD31XXXX0450           | 6.9URD31XXXX0450           |
| D3-1x-0255-B | 320000                                  | 6.9URD31XXXX0450           | 6.9URD31XXXX0450           | 6.9URD31XXXX0450           |
| D3-1x-0350-B | 202000                                  | 6.9URD31XXXX0550           | —                          | —                          |
| D3-1x-0425-B | 320000                                  | 6.9URD32XXXX0630           | —                          | —                          |
| D3-1x-0500-B | 320000                                  | 6.9URD32XXXX0700           | —                          | —                          |
| D3-1x-0700-B | 781000                                  | 6.9URD33XXX0900            | —                          | —                          |
| D3-1x-0820-B | 1200000                                 | 6.9URD33XXX1100            | —                          | —                          |
| D3-1x-0920-B | 2530000                                 | 6.9URD33XXX1250            | —                          | —                          |
| D3-1x-1000-B | 2530000                                 | 6.9URD33XXX1400            | —                          | —                          |
| D3-1x-0255-N | 320000                                  | 6.9URD31XXXX0450           | 6.9URD31XXXX0450           | 6.9URD31XXXX0450           |
| D3-1x-0360-N | 320000                                  | 6.9URD33XXX0630            | 6.9URD33XXX0630            | 6.9URD33XXX0630            |
| D3-1x-0430-N | 320000                                  | 6.9URD33XXX0700            | 6.9URD33XXX0700            | 6.9URD33XXX0700            |
| D3-1x-0650-N | 1200000                                 | 6.9URD33XXX1000            | 6.9URD33XXX1000            | 6.9URD33XXX1000            |
| D3-1x-0790-N | 2530000                                 | 6.6URD33XXX1400            | 6.6URD33XXX1400            | —                          |
| D3-1x-0930-N | 4500000                                 | 6.6URD33XXX1400            | 6.6URD33XXX1400            | —                          |
| D3-16-1200-N | 4500000                                 | 6URD233PLAF2200            | 6URD233PLAF2200            | —                          |
| D3-16-1410-N | 6480000                                 | 6URD233PLAF2200            | 6URD233PLAF2200            | —                          |
| D3-16-1600-N | 12500000                                | 6URD233PLAF2800            | 6URD233PLAF2800            | —                          |

XXX = blade type. See Ferraz/Mersen catalog for details.

**Table 4-7 Ferraz/Mersen fuses - AJT**

| Model        | SCR I <sup>2</sup> T (A <sup>2</sup> S) | Supply Voltage<br>(≤ 440 Vac) | Supply Voltage<br>(≤ 575 Vac) | Supply Voltage<br>(≤ 690 Vac) |
|--------------|---|-------------------------------|-------------------------------|-------------------------------|
| D3-1x-0023-B | 1150                                    | AJT25                         | AJT25                         | Not suitable                  |
| D3-1x-0043-B | 8000                                    | AJT50                         | AJT50                         |                               |
| D3-1x-0053-B | 15000                                   | AJT60                         | AJT60                         |                               |
| D3-1x-0076-B | 15000                                   | AJT80                         | AJT80                         |                               |
| D3-1x-0097-B | 512000                                  | AJT100                        | AJT100                        |                               |
| D3-1x-0105-B | 125000                                  | AJT125                        | AJT125                        |                               |
| D3-1x-0145-B | 125000                                  | AJT150                        | AJT150                        |                               |
| D3-1x-0170-B | 320000                                  | AJT175                        | AJT175                        |                               |
| D3-1x-0200-B | 320000                                  | AJT200                        | AJT200                        |                               |
| D3-1x-0220-B | 320000                                  | AJT250                        | AJT250                        |                               |
| D3-1x-0255-B | 320000                                  | AJT300                        | AJT300                        |                               |
| D3-1x-0350-B | 202000                                  | AJT400                        | AJT400                        |                               |
| D3-1x-0425-B | 238000                                  | AJT450                        | AJT450                        |                               |
| D3-1x-0500-B | 320000                                  | AJT500                        | AJT500                        |                               |
| D3-1x-0700-B | 781000                                  | A4BQ800                       | A4BQ800                       |                               |
| D3-1x-0820-B | 1200000                                 | A4BQ1200                      | A4BQ1200                      |                               |
| D3-1x-0920-B | 2530000                                 | A4BQ1200                      | A4BQ1200                      |                               |
| D3-1x-1000-B | 2530000                                 | A4BQ1200                      | A4BQ1200                      |                               |
| D3-1x-0255-N | 320000                                  | AJT300                        | AJT300                        |                               |
| D3-1x-0360-N | 320000                                  | AJT400                        | AJT400                        |                               |
| D3-1x-0430-N | 320000                                  | AJT450                        | AJT450                        |                               |
| D3-1x-0650-N | 1200000                                 | A4BQ800                       | A4BQ800                       |                               |
| D3-1x-0790-N | 2530000                                 | A4BQ1200                      | A4BQ1200                      |                               |
| D3-1x-0930-N | 4500000                                 | A4BQ1200 / A4BT1100           | A4BQ1200 / A4BT1100           |                               |
| D3-16-1200-N | 4500000                                 | A4BQ1600                      | A4BQ1600                      |                               |
| D3-16-1410-N | 6480000                                 | A4BQ2000                      | A4BQ2000                      |                               |
| D3-16-1600-N | 12500000                                | A4BQ2500 / A4BT1800           | A4BQ2500 / A4BT1800           |                               |

#### 4.4.2 UL Fuse Selection and Short Circuit Ratings

Two Short Circuit Current Ratings (SCCR) are available for UL compliant applications.

##### Standard Fault Currents (@ 600 VAC circuits)

The standard fault currents are determined with reference to UL508, section 51, table 51.3. This specifies the short circuit current that the starter must withstand based upon the soft starter model horsepower rating (or Full Load Current (FLC) rating or Locked Rotor Amps (LRA) depending upon model).

If using the Standard Fault Current Ratings, the fuse used must be in accordance with the information in the table below (i.e. model and manufacture specific).

##### High Available Fault Currents (@ 480 VAC circuits)

It is possible to specify short circuit current ratings exceeding the minimum ratings set by the Standard Fault Currents (see above) when the soft starter is capable of withstanding the high available short circuit current in accordance with the UL 508 test.

If using the High Available Fault Current Ratings, then a suitable fuse may be selected based upon Amperage and Fuse Class (J or L as applicable).

Table 4-8 UL fuse selection

| Model        | Nominal Rating (A) | Short Circuit Ratings |                                   |                        |   |  | 600 V Short cct rating – 3 cycles † |               |
|--------------|--------------------|-----------------------|-----------------------------------|------------------------|---|--|-------------------------------------|---------------|
|              |                    | High Available        |                                   | Standard Fault Current |   |  |                                     |               |
|              |                    | @ 480 VAC max.        | Max. Fuse Rating (A) (fuse class) | @ 600 VAC              | Ferraz/Mersen fuse, Listed J, L or RK5 Class Fuse | Ferraz/Mersen fuse, R/C semi-conductor fuses |                                     |               |
| D3-1x-0023-B | 23                 | 65 kA                 | 25 (J)                            | 10 kA                  | AJT25   | A070URD30XXX0063                             | Not available                       |               |
| D3-1x-0043-B | 43                 | 65 kA                 | 50 (J)                            | 10 kA                  | AJT50   | A070URD30XXX0125                             |                                     |               |
| D3-1x-0053-B | 53                 | 65 kA                 | 60 (J)                            | 10 kA                  | AJT60   | A070URD30XXX0125                             |                                     |               |
| D3-1x-0076-B | 76                 | 65 kA                 | 80 (J)                            | 10 kA                  | AJT80   | A070URD30XXX0200                             |                                     |               |
| D3-1x-0097-B | 97                 | 65 kA                 | 100 (J)                           | 10 kA                  | AJT100  | A070URD30XXX0200                             |                                     |               |
| D3-1x-0105-B | 105                | 65 kA                 | 125 (J)                           | 10 kA                  | AJT125  | A070URD30XXX0315                             |                                     |               |
| D3-1x-0145-B | 145                | 65 kA                 | 150 (J)                           | 18 kA                  | AJT150 / RK5 200                                  | A070URD30XXX0315                             |                                     |               |
| D3-1x-0170-B | 170                | 65 kA                 | 175 (J)                           | 18 kA                  | AJT175 / RK5 200                                  | A070URD30XXX0315                             |                                     |               |
| D3-1x-0200-B | 200                | 65 kA                 | 200 (J)                           | 18 kA                  | AJT200 / RK5 300                                  | A070URD30XXX0450                             |                                     |               |
| D3-1x-0220-B | 220                | 65 kA                 | 250 (J)                           | 18 kA                  | AJT250 / RK5 300                                  | A070URD30XXX0450                             |                                     |               |
| D3-1x-0255-B | 255                | 65 kA                 | 225 (J)                           | 18 kA                  | †   | -  | 18 kA – For 3 cycles                |               |
| D3-1x-0350-B | 350                | 65 kA                 | 225 (J)                           | 18 kA                  | †   | -  |                                     |               |
| D3-1x-0425-B | 425                | 65 kA                 | 350 (J)                           | 30 kA                  | †   | A070URD33XXX0630                             | 30 kA – For 3 cycles                |               |
| D3-1x-0500-B | 500                | 65 kA                 | 600 (J)                           | 30 kA                  | 600, Class J                                      | A070URD33XXX0700                             |                                     |               |
| D3-1x-0700-B | 700                | 65 kA                 | 800 (L)                           | 42 kA                  | 800, Class L                                      | -  | 42 kA – For 3 cycles                |               |
| D3-1x-0820-B | 820                | 65 kA                 | 1200 (L)                          | 42 kA                  | 1200, Class L                                     | A070URD33XXX1000                             |                                     |               |
| D3-1x-0920-B | 920                | 65 kA                 | 1200 (L)                          | 85 kA                  | 1200, Class L                                     | A070URD33XXX1400                             |                                     |               |
| D3-1x-1000-B | 1000               | 65 kA                 | 1200 (L)                          | 85 kA                  | 1200, Class L                                     | A070URD33XXX1400                             |                                     |               |
| D3-1x-0255-N | 255                | 65 kA                 | 200 (J)                           | 18 kA                  | AJT300  | A070URD30XXX0450                             |                                     | Not available |
| D3-1x-0360-N | 360                | 65 kA                 | 400 (J)                           | 18 kA                  | AJT400 / RK5 500                                  | A070URD33XXX0630                             |                                     |               |
| D3-1x-0430-N | 430                | 65 kA                 | 450 (J)                           | 30 kA                  | AJT450  | A070URD33XXX0700                             |                                     |               |
| D3-1x-0650-N | 650                | 65 kA                 | 800 (L)                           | 42 kA                  | A4BQ800   | A070URD33XXX1000                             |                                     |               |
| D3-1x-0790-N | 790                | 65 kA                 | 1200 (L)                          | 42 kA                  | A4BQ1200  | A070URD33XXX1400                             |                                     |               |
| D3-1x-0930-N | 930                | 65 kA                 | 1200 (L)                          | 42 kA                  | A4BQ1200  | A070URD33XXX1400                             |                                     |               |
| D3-16-1200-N | 1200               | 65 kA                 | 1600 (L)                          | 85 kA                  | A4BQ1600  | A065URD33XXX1800                             |                                     |               |
| D3-16-1410-N | 1410               | 65 kA                 | 2000 (L)                          | 85kA                   | A4BQ2000  | A055URD33XXX2250                             |                                     |               |
| D3-16-1600-N | 1600               | 65 kA                 | 2000 (L)                          | 85 kA                  | A4BQ2500  | A050URD33XXX2500                             |                                     |               |

XXX = blade type. Refer to Ferraz/Mersen catalog for details.

† - Models provided with a “3 cycle rating” are suitable for use in a circuit with the prospective current noted, when protected by any UL Listed fuses or UL Listed circuit breakers sized according to the NEC.

### 4.4.3 Control supply fuses

The following table lists the recommended control supply fuses. It is recommended that you use slow blow fuses which allow a 10A, 0.01 second surge.

**Table 4-9 Control supply fuses**

| Fuse type      |            | Part Number                       |
|----------------|------------|-----------------------------------|
| Ferraz Shawmut | Class J 1A | AJT1 (North America)              |
|                | IEC aM 1A  | 16511-G (10x38)                   |
|                |            | 17511-G (14x51)<br>15511-G (8x31) |
| Bussman        | Class J 1A | LPJ-1SP (North America)           |
|                | IEC aM 1A  | C08M1 (8x32)                      |
|                |            | C10M1 (10x38)                     |
| C14M1 (14x51)  |            |                                   |

### 4.5 Bypass contactor

Some Digistart D3 soft starters are internally bypassed and do not require an external bypass contactor.

Non-bypassed soft starters may be installed with an external bypass contactor. Select a contactor with an AC1 rating greater than or equal to the full load current rating of the connected motor.

Internally bypassed models:

D3-1x-0023-B, D3-1x-0043-B, D3-1x-0053-B, D3-1x-0076-B, D3-1x-0097-B, D3-1x-0105-B, D3-1x-0145-B, D3-1x-0170-B, D3-1x-0200-B, D3-1x-0220-B, D3-1x-0255-B, D3-1x-0350-B, D3-1x-0425-B, D3-1x-0500-B, D3-1x-0700-B, D3-1x-0820-B, D3-1x-0920-B, D3-1x-1000-B

Non-bypassed models:

D3-1x-0255-N, D3-1x-0360-N, D3-1x-0430-N, D3-1x-0650-N, D3-1x-0790-N, D3-1x-0930-N, D3-16-1200-N, D3-16-1410-N, D3-16-1600-N

### 4.6 Main contactor

Select a contactor with an AC3 rating greater than or equal to the full load current rating of the connected motor.

### 4.7 Circuit breaker

A shunt trip circuit breaker may be used instead of a main contactor to isolate the motor circuit in the event of a soft starter trip. The shunt trip mechanism must be powered from the supply side of the circuit breaker or from a separate control supply.

### 4.8 Power factor correction

If power factor correction is used, a dedicated contactor should be used to switch in the capacitors.



Power factor correction capacitors must be connected to the input side of the soft starter. Connecting power factor correction capacitors to the output side will damage the soft starter.

### 4.9 EMC (electromagnetic compatibility)

#### 4.9.1 Immunity

The Digistart D3 complies with the following international immunity standards as required for IEC60947-4-2:

**Table 4-10 EMC immunity**

| Standard      | Type of Immunity                        | Application              | Level   |
|---------------|---|--------------------------|---------|
| IEC61000-2-4  | Harmonics                               |                          | Class 3 |
| IEC61000-4-2  | Electrostatic Discharge                 | Housing of equipment     | Level 3 |
| IEC61000-4-3  | Radiated radio frequency field          | Housing of equipment     | Level 3 |
| IEC61000-4-4  | Successive rapid transients             | Control and power cables | Level 4 |
| IEC61000-4-5  | Surges                                  | Power cables             | Level 4 |
| IEC61000-4-6  | Conducted radio frequency               | Control and power cables | Level 3 |
| IEC61000-4-11 | Voltage dips & short time interruptions |                          | Class 2 |

#### 4.9.2 Conducted and radiated emissions

If the Digistart D3 is installed in accordance with the wiring instructions, the Digistart D3 complies with the following international immunity standards:

**Table 4-11 Conducted and radiated emissions**

| Standard     | Emissions   | Level    |
|--------------|---|----------|
| IEC60947-4-2 | Conducted on power supply from 150 kHz to 30MHz                   | Complies |
| IEC60947-4-2 | Radiated emissions from 30 to 1000 MHz (CISPR 11 Group 1 class B) | Complies |

## 5. Keypad and Status

### 5.1 Keypad

Figure 5-1 Keypad and display

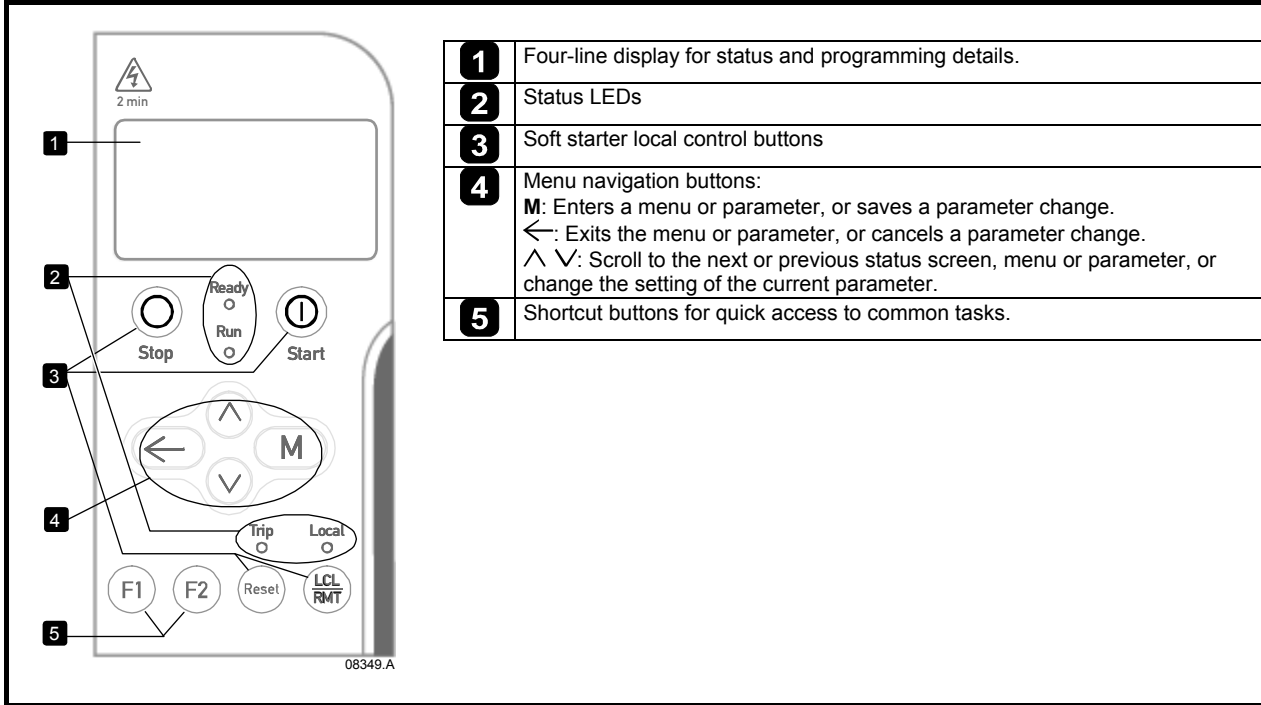

Table 5-1 Feedback LEDs

| LED name | On                 | Flashing   | Off                               |
|----------|--------------------|--|-----------------------------------|
| Ready    | Ready              | Restart delay or motor temperature check or DI4 not closed (default setting) | No control power                  |
| Run      | Running            | Starting/ stopping   | Not running, starting or stopping |
| Trip     | Starter tripped    | Warning  | Normal operation                  |
| Local    | Local control mode | n/a  | Remote control mode               |

### 5.2 Removing and replacing the keypad

The keypad can be removed from the soft starter and mounted remotely on a panel using the remote mounting kit.

The keypad stores a backup copy of the parameters in the soft starter, so one keypad can be used to program multiple Digistart D3 starters.

**NOTE** The keypad can be removed or replaced while the starter is running. It is not necessary to remove mains or control voltage.



It is the installer's responsibility to ensure that any enclosure which allows access to models D3-1x-0145-B to D3-1x-1000-B and D3-1x-0255-N to D3-16-1600-N while the product is energized, provides protection against contact and ingress requirements of IP20.

#### 5.2.1 Removing the keypad

The keypad is attached to the body of the soft starter by a DB9 serial connector and two screws. The screws are concealed behind a snap-on faceplate.

To remove the keypad:

1. Models D3-1x-0023-B to D3-1x-1000-B: open the Digistart D3's door.  
 Models D3-1x-0255-N to D3-16-1600-N: remove the Digistart D3's front cover.
2. Insert a small screwdriver under the faceplate, at the base of the keypad, and use the screwdriver to lever the faceplate off the keypad.
3. Lift the faceplate off completely.
4. Remove the two screws holding the keypad in place.
5. Lift the keypad gently off the soft starter. Pull the keypad forwards, to avoid damaging the DB9 connector.

## 5.2.2 Reattaching the keypad

To reattach the keypad:

1. Align the connector on the back of the keypad with the socket on the soft starter and push the keypad firmly into place. The keypad will be held in place by the connector and two locating nibs in the top right and bottom left corners. For temporary installation (eg during commissioning) it is not necessary to screw the keypad in place.
2. Replace the two screws holding the keypad in place.
3. Slide the bottom edge of the faceplate over the body of the keypad, then swing the top edge of the faceplate into place and press onto the keypad. The retaining tabs on the back of the faceplate will snap into place.

## 5.3 Synchronising the keypad and the starter

When a keypad is connected to a Digistart D3, it synchronises its parameter settings with the settings in the soft starter.

Every time a different keypad is plugged into the starter, an acknowledgement is displayed.

New Display Detected

Select the required option using the  $\wedge$  and  $\vee$  buttons. Press **M** to proceed with the selection.

Copy Parameters  
Display to Starter  
Starter to Display

If any of the settings in the keypad are not valid for the starter, the keypad loads the default values.

**NOTE** If a setting in the keypad is not valid for the starter, the keypad will display the message "Par. xx Out of Range".

## 5.4 Displays

The keypad displays a wide range of performance information about the soft starter.

The top half of the screen shows real-time information on starter status, motor temperature and motor power.

Use the  $\wedge$  and  $\vee$  buttons to select the information shown on the bottom half of the screen.

- Current
- Last start information
- Date and time

### 5.4.1 Starter status

The starter status screen shows details of the starter's operating status, motor temperature and motor power.

Ready  
M1 000%                      000.0kW

### 5.4.2 Average current

The average current screen shows real-time average current.

0.0A

### 5.4.3 Programmable screen

The Digistart D3's user-programmable screen can be configured to show the most important information for the particular application. Use Pr **9B** to **9E** to select which information to display.

000.0A                      0.0pf  
00000hrs                    000kWh

### 5.4.4 Current

The current screen shows real-time line current on each phase. If the RTD/PT100 and ground fault protection card is fitted, the screen will also show ground current.

Phase Currents  
000.0A    000.0A    000.0A

### 5.4.5 Last start information

The last start information screen shows details of the most recent successful start:

- start duration (seconds)
- maximum start current drawn (as a percentage of motor full load current)
- calculated rise in motor temperature

Last start                      010 s  
350 % FLC                     $\Delta$  Temp 5%

|                    |             |                         |                         |                          |                           |           |             |             |                      |                |             |         |
|--------------------|-------------|-------------------------|-------------------------|--------------------------|---------------------------|-----------|-------------|-------------|----------------------|----------------|-------------|---------|
| Safety Information | Rating Data | Mechanical Installation | Electrical Installation | <b>Keypad and Status</b> | Quick Start Commissioning | Operation | Programming | Diagnostics | Application Examples | Technical Data | Maintenance | Options |
|--------------------|-------------|-------------------------|-------------------------|--------------------------|---------------------------|-----------|-------------|-------------|----------------------|----------------|-------------|---------|

### 5.4.6 Date and time

The date/time screen shows the current system date and time (24 hour format). For details on setting the date and time, see *Set date and time* on page 67.

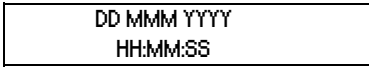

### 5.4.7 Performance graph

The performance graph provides a real-time display of operating performance. Use Pr **9F** to **9I** to select which information to display.

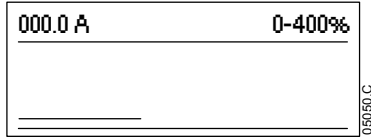

## 6. Quick Start Commissioning

This procedure is written from default parameter settings as the starter would be delivered from the factory.



Always apply control voltage before (or with) mains voltage.

### 6.1 Control wiring

Figure 6-1 Control terminals for basic connection

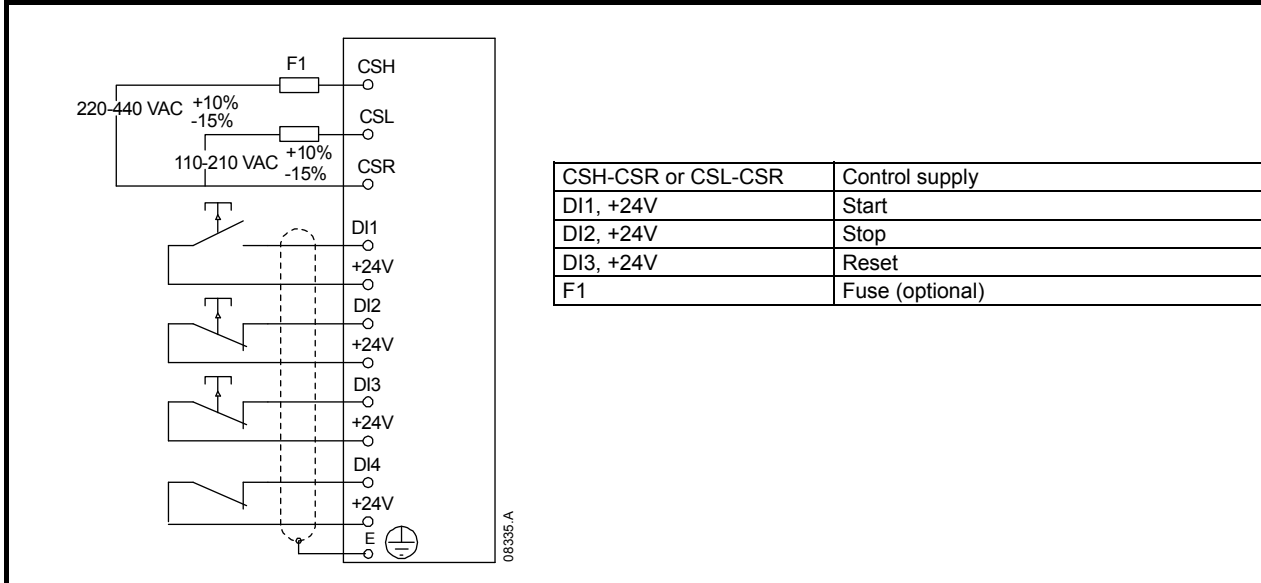

For keypad control, the soft starter requires:

- control supply connections (terminals CSH, CSL, CSR depending on the control voltage)
- programmable input A (DI4, +24V) must be closed or Pr **3A Input A Function** must be changed from Starter Disable

## 6.2 Setup procedure

Table 6-1 Basic setup procedure

| Action               | Detail   |
|----------------------|--|
| Before power-up      | <p>Ensure:</p> <ul style="list-style-type: none"> <li>• The starter is not receiving a start signal</li> <li>• The motor is connected to the starter</li> <li>• The motor connection is correct</li> <li>• The correct supply voltage is available</li> </ul>  |
| Power up the starter | <p>Ensure:</p> <ul style="list-style-type: none"> <li>• The Ready LED activates</li> </ul>   |
| Program parameters   | <p>The Quick Setup Menu makes it easy to configure the Digistart D3 for common applications. The Digistart D3 selects the parameters relevant to the application and suggests a typical setting, and you can adjust each parameter to suit your exact requirements.</p> <p>Press the <b>M</b> button.</p> <p>To validate the Quick Setup Menu, press <b>M</b> again.</p> <p>Select the application of your choice from the list.</p> <p>The following applications are available through the Quick Setup Menu:</p> <ul style="list-style-type: none"> <li>• Pump (centrifugal, submersible)</li> <li>• Fan (damped, undamped)</li> <li>• Compressor (screw, reciprocating)</li> <li>• Conveyor</li> <li>• Crusher (rotary, jaw)</li> </ul> <p>Use the <b>M</b> button to select the characteristics you want to modify and adjust the value using <math>\wedge</math> and <math>\vee</math>.</p> <p>To confirm the selection, press the <b>M</b> key.</p> <p>To exit the Quick Setup Menu and go back to the standard display, press <math>\leftarrow</math> several times.</p> <p>For more information on the Quick Setup Menu, see <i>Quick setup details</i>.</p> <p>For applications not covered by the Quick Setup Menu, select the Standard Menu, then Menu 1 - Primary Motor Set and Menu 2 - Start/Stop Modes-1.</p> <p>Press <b>M</b> to enter in the required menu.</p> <p>The following parameters should be set to suit the requirements of the application:</p> <ul style="list-style-type: none"> <li>• <b>1A Motor Full Load Current</b></li> <li>• <b>2A Start Mode</b></li> <li>• <b>2B Current Limit</b></li> <li>• <b>2D Start Ramp Time</b></li> <li>• <b>2I Stop Time</b></li> <li>• <b>2H Stop Mode</b> (if required)</li> </ul> <p>For parameter details, see <i>Parameter descriptions</i> on page 53.</p> |
| Start the motor      | <p>Ensure:</p> <ul style="list-style-type: none"> <li>• The status screen is shown on the starter display</li> <li>• The following terminals are closed: DI4, +24V, DI2, +24V and DI3, +24V</li> </ul> <p>To start the motor, close terminal DI1, +24V.</p> <p>To stop the motor, open terminal DI2, +24V.</p>   |

## 7. Operation

### 7.1 Start, stop and reset commands

The soft starter can be controlled in three ways:

- using the buttons on the keypad
- via remote inputs
- via a serial communication link

The **LCL/RMT** button controls whether the Digistart D3 will respond to local control (via the keypad) or remote control (via the remote inputs).

- The Local LED on the keypad is on when the soft starter is in local control mode and off when the soft starter is in remote control mode.
- The Remote LED on the Digistart D3 is on when the soft starter is in Remote mode and off when in Local mode. The Remote LED is located on the main body of the starter (behind the keypad) and is only visible if the keypad is remotely mounted.

Control via the serial communication network is always enabled in local control mode, and can be enabled or disabled in remote control mode (Pr **30 Comms in Remote**). Control via the serial communication network requires an optional communication module.

The **STOP** button on the keypad is always enabled.

To reset a trip on the soft starter, press the **RESET** button on the keypad or activate the Reset remote input.

**NOTE** Adaptive Control, Jog, Brake and PowerThrough functions are not supported with inside delta (six-wire) operation. See *Inside delta operation* on page 44.

### 7.2 Soft start methods

Soft starters offer a variety of methods to control motor starting. Each soft start method uses a different primary control parameter.

**Table 7-1 Soft start methods**

| Soft Start Method  | Parameter Controlled | Performance Parameters Influenced         |
|--------------------|----------------------|---|
| Timed Voltage Ramp | Voltage              | Start current, start torque, acceleration |
| Constant Current   | Current              | Start torque, acceleration                |
| Torque Control     | Torque               | Start current, acceleration               |
| Adaptive Control   | Acceleration         | Start current, start torque               |

Best results are obtained by selecting the soft start method that directly controls the parameter of most importance for the application. Typically soft starters are used to limit motor start current or control load acceleration and/or deceleration.

The Digistart D3 offers Constant Current or Adaptive Control. Use Pr **2A** to select the soft start method.

**Table 7-2 Control functions of soft start methods**

| To Control              | Use              |
|-------------------------|------------------|
| Motor Start Current     | Constant Current |
| Motor/Load Acceleration | Adaptive Control |

To soft start the motor, press the **START** button on the keypad or activate the Start remote input. The motor will start using the start mode selected in Pr **2A**.

#### 7.2.1 Constant current

Constant current is the traditional form of soft starting, which raises the current from zero to a specified level and keeps the current stable at that level until the motor has accelerated.

Constant current starting is ideal for applications where the start current must be kept below a particular level.

**Figure 7-1 Constant current soft start**

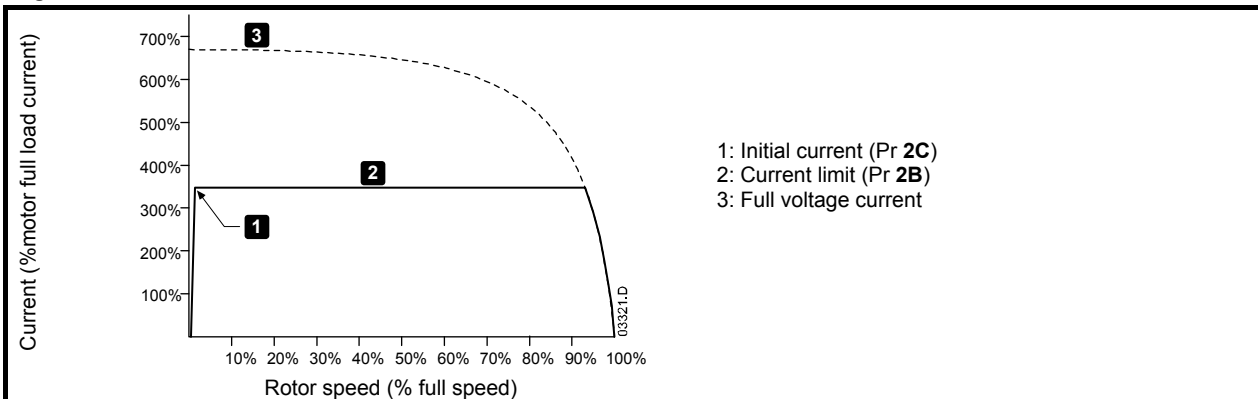

## 7.2.2 Current ramp

Current ramp soft starting raises the current from a specified starting level (1) to a maximum limit (3), over an extended period of time (2).

Current ramp starting can be useful for applications where:

- the load can vary between starts (for example a conveyor which may start loaded or unloaded). Set the initial current (Pr **2C**) to a level that will start the motor with a light load, and the current limit (Pr **2B**) to a level that will start the motor with a heavy load.
- the load breaks away easily, but starting time needs to be extended (for example a centrifugal pump where pipeline pressure needs to build up slowly).
- the electricity supply is limited (for example a generator set), and a slower application of load will allow greater time for the supply to respond.

Figure 7-2 Current ramp soft start

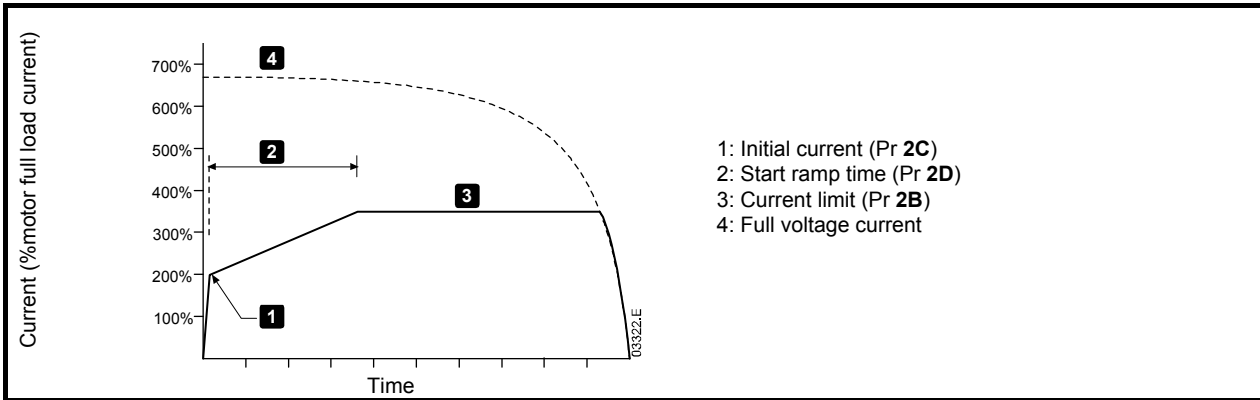

## 7.2.3 Adaptive control for starting

In an adaptive control soft start, the Digistart D3 adjusts the current in order to start the motor within a specified time and using a selected acceleration profile.



Adaptive Control cannot start the motor faster than a direct on-line (DOL) start. If the start ramp time (Pr **2D**) is shorter than the motor's DOL start time, starting current may reach DOL levels.

Every application has a particular starting profile, based on characteristics of the load and the motor. Adaptive Control offers three different starting profiles, to suit the requirements of different applications. Selecting a profile that matches the inherent profile of the application can help smooth out acceleration across the full start time. Selecting a dramatically different Adaptive Control profile can somewhat neutralise the inherent profile.

The Digistart D3 monitors the motor's performance during each start, to improve control for future soft starts.

### Adaptive control

To use Adaptive Control to control starting performance:

1. Select Adaptive Control from the Start Mode menu (Pr **2A**)
2. Set the desired Start Ramp Time (Pr **2D**)
3. Select the desired Adaptive Start Profile (Pr **2E**)
4. Set a start Current Limit (Pr **2B**) sufficiently high to allow a successful start. The first Adaptive Control start will be a Constant Current start. This allows the Digistart D3 to learn the characteristics of the connected motor. This motor data is used by the Digistart D3 during subsequent Adaptive Control starts.

Figure 7-3 Adaptive control soft start

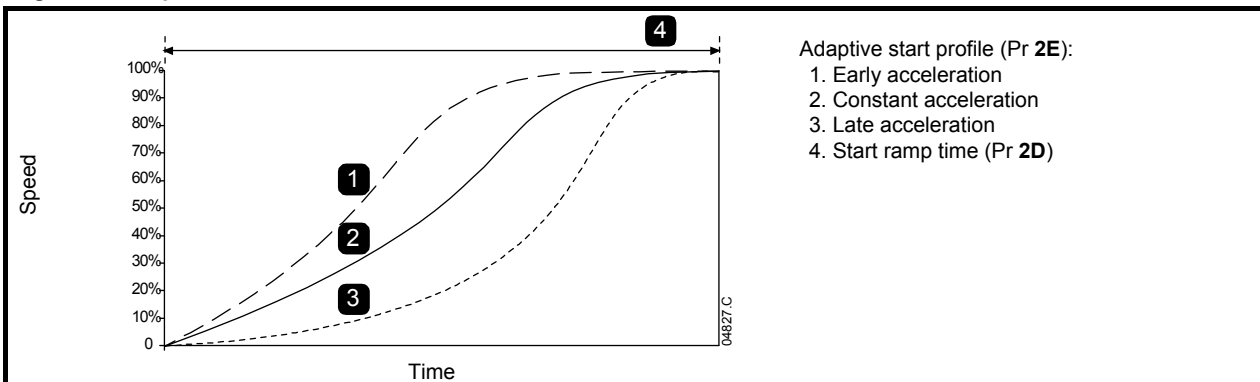

**NOTE** Adaptive Control will control the load according to the programmed profile. Start current will vary according to the selected acceleration profile and the programmed start time.

If replacing a motor connected to a Digistart D3 programmed for Adaptive Control starting or stopping, or if the starter has been tested on a different motor prior to actual installation, the starter will need to learn the characteristics of the new motor. The Digistart D3 will automatically re-learn the motor's characteristics if Pr **1A Motor Full Load Current** or Pr **2L Adaptive Control Gain** is changed.

### How to select the adaptive control start profile

The best profile will depend on the exact details of each application.

Some loads, such as submersible pumps, should not be run at slow speeds. An early acceleration profile will raise the speed quickly, then control acceleration through the rest of the start.



Adaptive Control controls the motor's speed profile, within the programmed time limit. This may result in a higher level of current than traditional control methods.

### Fine-tuning adaptive control

If the motor does not start or stop smoothly, adjust the adaptive control gain (Pr **2L**). The gain setting determines how much the Digistart D3 will adjust future adaptive control starts and stops, based on information from the previous start. The gain setting affects both starting and stopping performance.

- If the motor accelerates or decelerates too quickly at the end of a start or stop, increase the gain setting by 5% to 10%.
- If the motor speed fluctuates during starting or stopping, decrease the gain setting slightly.

**NOTE** Changing the gain setting resets the starter's adaptive control learning. The first start after changing the gain will use constant current.

### 7.2.4 Kickstart

Kickstart provides a short boost of extra torque at the beginning of a start, and can be used in conjunction with current ramp or constant current starting.

Kickstart can be useful to help start loads that require high breakaway torque but then accelerate easily (for example flywheel loads such as presses).

**Figure 7-4 Current ramp soft start with kickstart**

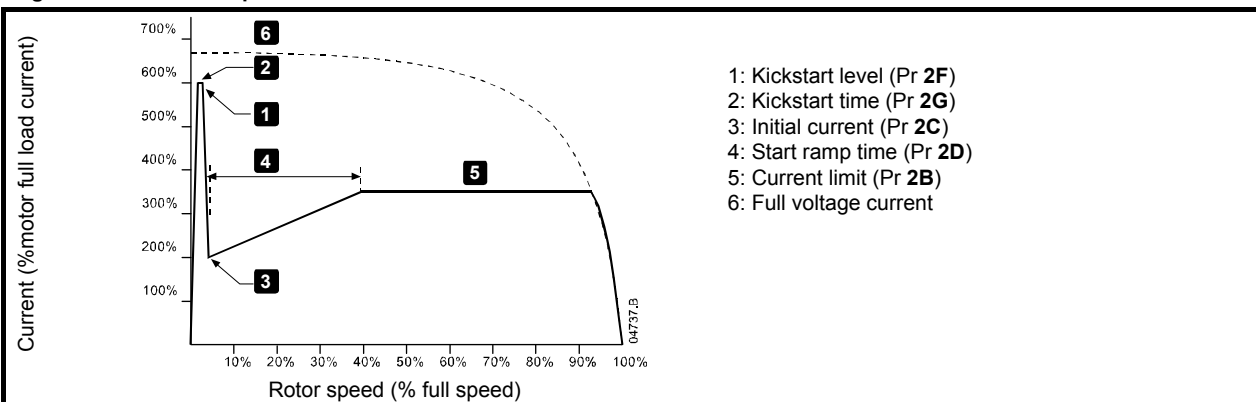

Kickstart subjects the mechanical equipment to increased torque levels. Ensure the motor, load and couplings can handle the additional torque before using this feature.

## 7.3 Stop methods

Soft starters offer a variety of methods for the control of motor stopping.

**Table 7-3 Soft stop methods**

| Stop Method      | Performance Result  |
|------------------|---|
| Coast To Stop    | Natural load run down   |
| TVR Soft Stop    | Extended run down time  |
| Adaptive Control | Extended run down time according to selected deceleration profile |
| Brake            | Reduced run down time   |

Soft starters are often used in pumping applications to eliminate the damaging effects of fluid hammer. Adaptive Control should be the preferred stop method for these applications.

To stop the motor, press the **STOP** button on the keypad or activate the Stop remote input. The motor will stop using the stop mode selected in Pr 2H.

### 7.3.1 Coast to stop

Coast to stop lets the motor slow at its natural rate, with no control from the soft starter. The time required to stop will depend on the type of load.

### 7.3.2 TVR soft stop

Timed voltage ramp reduces the voltage to the motor gradually over a defined time. The load may continue to run after the stop ramp is complete.

Timed voltage ramp stopping can be useful for applications where the stop time needs to be extended, or to avoid transients on generator set supplies.

**Figure 7-5 TVR soft stop**

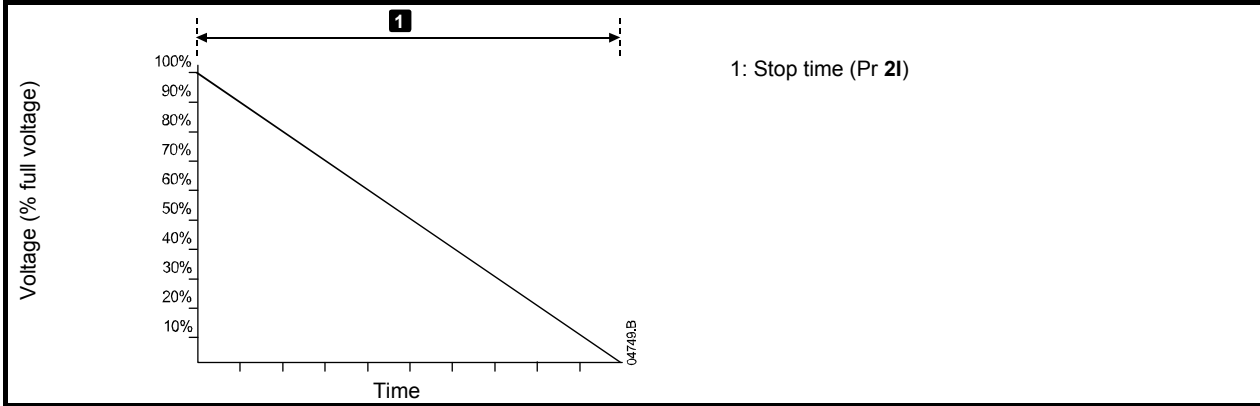

### 7.3.3 Adaptive control for stopping

In an adaptive control soft stop, the Digistart D3 controls the current in order to stop the motor within a specified time and using a selected deceleration profile. Adaptive Control can be useful in extending the stopping time of low inertia loads.

**NOTE** Adaptive control does not actively slow the motor down and will not stop the motor faster than a coast to stop. To shorten the stopping time of high inertia loads, use brake.

Every application has a particular stopping profile, based on characteristics of the load and the motor. Adaptive Control offers three different stopping profiles. Choose the adaptive control profile that best matches your application requirements.

#### Adaptive control

To use Adaptive Control to control stopping performance:

1. Select Adaptive Control from the Stop Mode menu (Pr 2H)
2. Set the desired Stop Time (Pr 2I)
3. Select the required Adaptive Stop Profile (Pr 2K)

**Figure 7-6 Adaptive control soft stop**

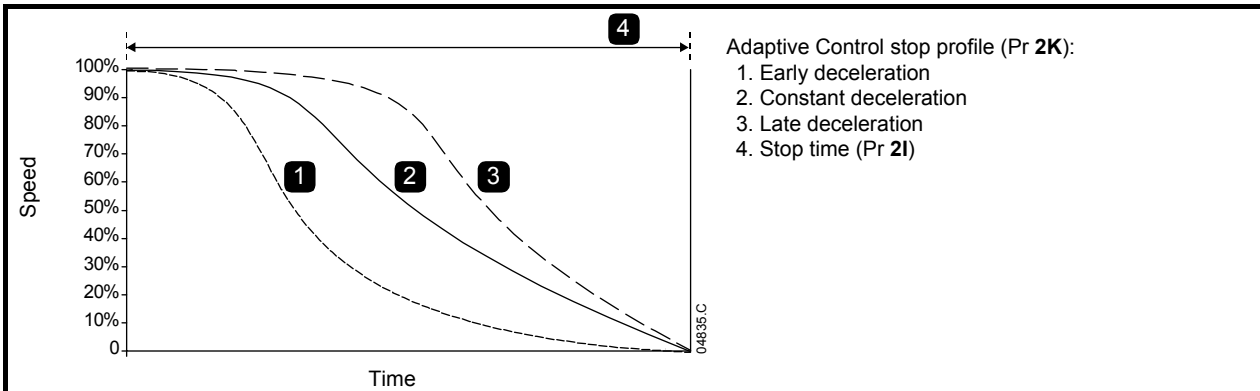

- Pump stopping

The hydraulic characteristics of pump systems vary considerably. This variation means the ideal deceleration profile and stop time will vary from application to application. The table provides guidelines on selecting between Adaptive Control deceleration profiles, but we recommend testing the three profiles to identify the best profile for the application.

**Table 7-4 Adaptive stop profiles**

| Adaptive Stop Profile | Application  |
|-----------------------|--|
| Late Deceleration     | High head systems where even a small decrease in motor/pump speed results in a rapid transition between forward flow and reverse flow. |
| Constant Deceleration | Low to medium head, high flow applications where the fluid has high momentum.  |
| Early Deceleration    | Open pump systems where fluid must drain back through the pump without driving the pump in reverse.                                    |

The first Adaptive Control stop will be a normal soft stop. This allows the Digistart D3 to learn the characteristics of the connected motor. This motor data is used by the Digistart D3 during subsequent Adaptive Control stops.

**NOTE** Adaptive Control will control the load according to the programmed profile. Stopping current will vary according to the selected deceleration profile and stop time.

If replacing a motor connected to a Digistart D3 programmed for Adaptive Control starting or stopping, or if the starter has been tested on a different motor prior to actual installation, the starter will need to learn the characteristics of the new motor. The Digistart D3 will automatically re-learn the motor's characteristics if Pr **1A Motor Full Load Current** or Pr **2L Adaptive Control Gain** is changed.

### How to select the adaptive control stop profile

The best profile will depend on the exact details of each application.



Adaptive Control controls the motor's speed profile, within the programmed time limit. This may result in a higher level of current than traditional control methods.

### Fine-tuning adaptive control

If the motor does not start or stop smoothly, adjust the adaptive control gain (Pr **2L**). The gain setting determines how much the Digistart D3 will adjust future adaptive control starts and stops, based on information from the previous start. The gain setting affects both starting and stopping performance.

- If the motor accelerates or decelerates too quickly at the end of a start or stop, increase the gain setting by 5% to 10%.
- If the motor speed fluctuates during starting or stopping, decrease the gain setting slightly.

**NOTE** Changing the gain setting resets the starter's adaptive control learning. The first start after changing the gain will use constant current.

### 7.3.4 Brake

Brake reduces the time the motor requires to stop.

During braking an increased noise level from the motor may be audible. This is a normal part of motor braking.



If the brake torque is set too high, the motor will stop before the end of the brake time and the motor will suffer unnecessary heating which could result in damage. Careful configuration is required to ensure safe operation of the starter and motor.

A high brake torque setting can result in peak currents up to motor DOL being drawn while the motor is stopping. Ensure protection fuses installed in the motor branch circuit are selected appropriately.



Brake operation causes the motor to heat faster than the rate calculated by the motor thermal model. If you are using brake, install a motor thermistor or allow sufficient restart delay (Pr **6G**).

### Brake

When brake is selected, the Digistart D3 uses DC injection to slow the motor.

Digistart D3 braking:

- Does not require the use of a DC brake contactor
- Controls all three phases so that the braking currents and associated heating are evenly distributed through the motor.

Braking has two stages:

- Pre-brake: provides an intermediate level of braking to slow motor speed to a point where full brake can be operated successfully (approximately 70% speed).
- Full brake: brake provides maximum braking torque but is ineffective at speeds greater than approximately 70%.

To configure the Digistart D3 for brake operation:

1. Set Pr **2I** for the desired stopping time duration (1). This is the total braking time and must be set sufficiently longer than the brake time (Pr **2N**) to allow the pre-braking stage to reduce motor speed to approximately 70%. If the stop time is too short, braking will not be successful and the motor will coast to stop.
2. Set Brake Time (Pr **2N**) to approximately one quarter of the programmed Stop Time. This sets the time for the Full Brake stage (2).
3. Adjust the Brake Torque (Pr **2M**) so that the desired stopping performance is achieved. If set too low, the motor will not stop completely and will coast to stop by the end of the braking period.

**Figure 7-7 DC brake stop**

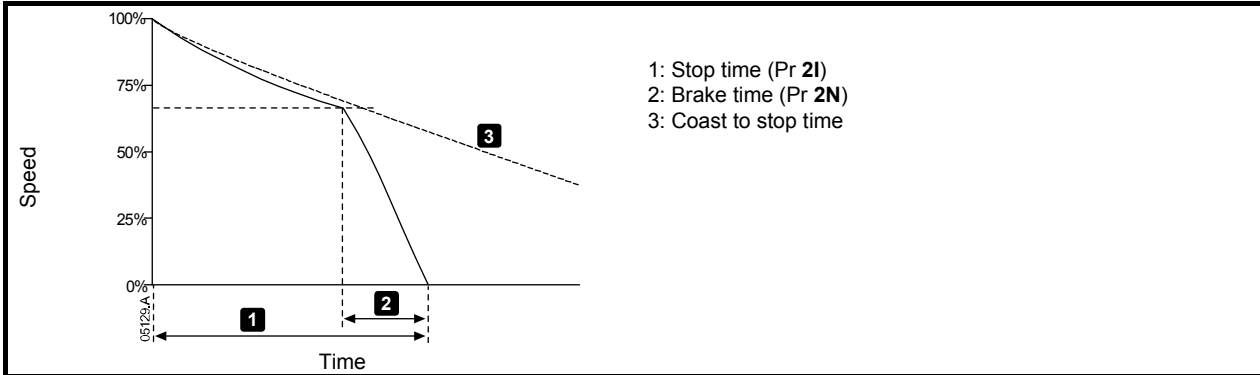

When using DC brake, the mains supply must be connected to the soft starter (input terminals L1, L2, L3) in positive phase sequence and Pr **5D Phase Sequence** must be set to Positive Only.

**NOTE**

For loads which may vary between braking cycles, install a zero speed sensor to ensure that the soft starter ends DC braking when the motor stops. This avoids unnecessary heating of the motor.

For more information on using the Digistart D3 with an external speed sensor (eg for applications with variable load during the braking cycle), see *DC Brake with External Zero Speed Sensor*.

## 7.4 Jog operation

Jog runs the motor at reduced speed, to allow alignment of the load or to assist servicing. The motor can be jogged in either forward or reverse direction.



Slow speed running is not intended for continuous operation due to reduced motor cooling.

Jog operation causes the motor to heat faster than the rate calculated by the motor thermal model. If you are using jog, install a motor thermistor or allow sufficient restart delay (Pr **6G**)

**NOTE** Soft start and soft stop are not available during jog operation.

Jog is only available for the primary motor. For more information on primary and secondary motor sets, see *Group 11 - Secondary Motor Settings* on page 64.

The maximum available torque for jog forward is approximately 50% to 75% of motor full load torque (FLT) depending on the motor. The torque when the motor is jogged in reverse is approximately 25% to 50% of FLT.

Pr **15E** controls how much of the maximum available jog torque the soft starter will apply to the motor.

**NOTE** Setting Pr **15E** above 50% may cause increased shaft vibration.

Figure 7-8 Jog operation

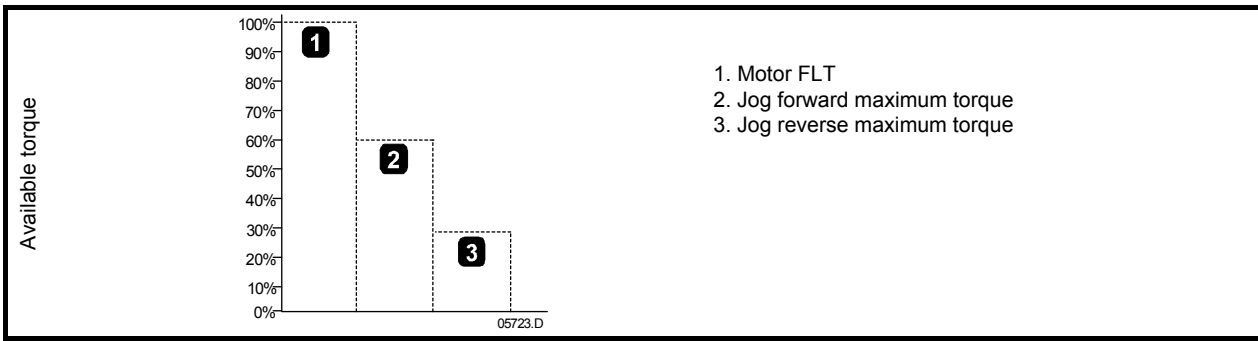

To activate jog operation, use either a programmable input (see Pr **3A** and **3F**, will operate only in Remote Mode) or a shortcut key (Pr **9J** and **9K**).

To stop a jog operation, perform one of the following:

- Remove the jog command.
- Press the **STOP** button on the keypad.

Jog will recommence at the end of a restart delay if the jog command is still present. All other commands except the above, will be ignored during jog operation.

## 7.5 Inside delta operation

Adaptive Control, Jog, Brake and PowerThrough functions are not supported with inside delta (six-wire) operation. If these functions are programmed when the starter is connected inside delta the behaviour is as given below:

Table 7-5 Inside delta compatibility

|                        |   |
|------------------------|---|
| Adaptive Control Start | The starter performs a constant current start.  |
| Adaptive Control Stop  | The starter performs a TVR soft stop if Pr <b>2I Stop Time</b> is >0 secs. If Pr <b>2I</b> is set to 0 secs the starter performs a coast to stop. |
| Jog                    | The starter issues a warning with the error message Unsupported Option.   |
| Brake                  | The starter performs a coast to stop.   |
| PowerThrough           | The starter trips with the error message Lx-Tx Shorted.   |

For more information on PowerThrough, see Pr **15D Shorted SCR Action**.

**NOTE** When connected in inside delta, current imbalance is the only phase loss protection that is active during run. Do not disable current imbalance protection (Pr **5C**) during inside delta operation.

## 8. Programming



The motor data parameters are critical to the correct operation of the soft starter's thermal model, and to the motor overload protection. Always set Pr **1A** to suit the motor's characteristics. The default settings of Pr **1B**, **1C** and **1D** are suitable for most applications. Consult the motor datasheet before changing these settings.

### 8.1 Programming menu

The Programming Menu lets you view and change programmable parameters that control how the Digistart D3 operates.

To open the Programming Menu, press the **M** button while viewing the monitoring screens.

To navigate through the Programming Menu:

- to scroll through parameter groups, press the  $\wedge$  or  $\vee$  button.
- to open a submenu, press the **M** button.
- to view the parameters in a group, press the **M** button.
- to return to the previous level, press the  $\leftarrow$  button.
- to close the Programming Menu, press  $\leftarrow$  repeatedly.

To change a parameter value:

- scroll to the appropriate parameter in the Programming Menu and press **M** to enter edit mode.
- to alter the parameter setting, use the  $\wedge$  and  $\vee$  buttons. Pressing  $\wedge$  or  $\vee$  once will increase or decrease the value by one unit. If the button is held for longer than five seconds, the value will increase or decrease at a faster rate.
- to save changes, press **M**. The setting shown on the display will be saved and the keypad will return to the parameter list.
- to cancel changes, press  $\leftarrow$ . The keypad will ask for confirmation, then return to the parameter list without saving changes.

The Programming Menu contains the following sub-menus.

**Table 8-1 Programming Menu structure**

|                         |   |
|-------------------------|---|
| <b>Quick Setup Menu</b> | The Quick Setup Menu allows you to select common applications and guides you through the parameter setup process for these applications.  |
| <b>Standard Menu</b>    | The Standard Menu provides access to commonly used parameters, allowing you to configure the Digistart D3 to suit your application.   |
| <b>Advanced Menu</b>    | The Advanced Menu provides access to all the Digistart D3's programmable parameters, allowing experienced users to take advantage of advanced features.                             |
| <b>Setup Tools</b>      | Setup Tools provides access to functions to save the current parameter settings to a file, load parameters from a previously saved file, or reset all parameters to default values. |
| <b>Simulations</b>      | Simulations allows you to simulate operation of the soft starter, including input and output functions.   |
| <b>I/O State</b>        | I/O State provides access to information on the current state of the analog and digital inputs and outputs.   |
| <b>Logs</b>             | The Logs Menu provides access to the Trip Log and Event Log.  |
| <b>Counters</b>         | The Counters Menu provides access to information on the starter's operating history.  |

### 8.2 Access code

Critical parameters (parameter group 15 and higher) are protected by a four-digit security access code, preventing unauthorised users from viewing or modifying parameter settings.

When a user attempts to enter a restricted parameter group, the keypad prompts for an access code. The access code is requested once for the programming session, and authorisation continues until the user closes the menu.

To enter the access code, use the  $\leftarrow$  and **M** buttons to select a digit, and the  $\wedge$  and  $\vee$  buttons to change the value. When all four digits match your access code, press **M**. The keypad will display an acknowledgement message before continuing.

|                              |          |
|------------------------------|----------|
| Enter Access Code<br>0####   | <b>M</b> |
| Access Allowed<br>SUPERVISOR |          |

To change the access code, use Pr **15A**.

The simulation tools and counter resets are also protected by the security access code.

The default access code is 0000.

### 8.3 Adjustment lock

You can lock the Programming Menu to prevent users from altering parameter settings. The adjustment lock can be turned on and off using Pr **15C**.

To lock the programming menu:

1. Open the Programming Menu.
2. Open the Advanced Menu.
3. Select 'Restricted'.
4. Enter the Access Code
5. Select Pr **15C** *Adjustment Lock*.
6. Select and store 'Read Only'.

If a user attempts to change a parameter value when the adjustment lock is active, an error message is displayed:

|                                 |
|---------------------------------|
| Access Denied<br>Adj Lock is On |
|---------------------------------|

### 8.4 Load defaults

Load Defaults restores the starter to the factory default settings for all parameters except Pr **9A** *Language*. This does not reset the access code.

To load defaults:

1. Open the Programming Menu and select Setup Tools. Enter the access code.
2. Scroll to the required function and press the **M** button.
3. At the confirmation prompt, select YES to confirm or NO to cancel and then **M** to load/save the selection.

|   |
|---|
| Load Defaults<br>Load Backup<br>Save User Set 1 |
|---|

|                            |
|----------------------------|
| Load Defaults<br>No<br>Yes |
|----------------------------|

When the action has been completed, the screen will briefly display a confirmation message, then return to the status screens.

## 8.5 Quick setup details

To access the Quick Setup Menu, press the **M** button and select Quick Setup Menu.

The Quick Setup Menu makes it easy to configure the Digistart D3 for common applications. The Digistart D3 selects the parameters relevant to the application and suggests a typical setting, and you can adjust each parameter to suit your exact requirements.

Always set Pr **1A Motor Full Load Current** to match the motor's nameplate full load current. The suggested value is the starter's minimum full load current.

**Table 8-2 Quick setup menu**

| Application      | Parameter                      | Pr Number | Suggested value       |
|------------------|--------------------------------|-----------|-----------------------|
| Pump Centrifugal | <i>Motor Full Load Current</i> | <b>1A</b> | Model dependent       |
|                  | <i>Start Mode</i>              | <b>2A</b> | Adaptive Control      |
|                  | <i>Adaptive Start Profile</i>  | <b>2E</b> | Early Acceleration    |
|                  | <i>Start Ramp Time</i>         | <b>2D</b> | 10 seconds            |
|                  | <i>Stop Mode</i>               | <b>2H</b> | Adaptive Control      |
|                  | <i>Adaptive Stop Profile</i>   | <b>2K</b> | Late Deceleration     |
|                  | <i>Stop Time</i>               | <b>2I</b> | 15 seconds            |
| Pump Submersible | <i>Motor Full Load Current</i> | <b>1A</b> | Model dependent       |
|                  | <i>Start Mode</i>              | <b>2A</b> | Adaptive Control      |
|                  | <i>Adaptive Start Profile</i>  | <b>2E</b> | Early Acceleration    |
|                  | <i>Start Ramp Time</i>         | <b>2D</b> | 5 seconds             |
|                  | <i>Stop Mode</i>               | <b>2H</b> | Adaptive Control      |
|                  | <i>Adaptive Stop Profile</i>   | <b>2K</b> | Late Deceleration     |
|                  | <i>Stop Time</i>               | <b>2I</b> | 5 seconds             |
| Fan Damped       | <i>Motor Full Load Current</i> | <b>1A</b> | Model dependent       |
|                  | <i>Start Mode</i>              | <b>2A</b> | Constant Current      |
|                  | <i>Current Limit</i>           | <b>2B</b> | 350%                  |
| Fan Undamped     | <i>Motor Full Load Current</i> | <b>1A</b> | Model dependent       |
|                  | <i>Start Mode</i>              | <b>2A</b> | Adaptive Control      |
|                  | <i>Adaptive Start Profile</i>  | <b>2E</b> | Constant Acceleration |
|                  | <i>Start Ramp Time</i>         | <b>2D</b> | 20 seconds            |
|                  | <i>Excess Start Time</i>       | <b>5A</b> | 30 seconds            |
|                  | <i>Locked Rotor Time</i>       | <b>1C</b> | 20 seconds            |
| Compressor Screw | <i>Motor Full Load Current</i> | <b>1A</b> | Model dependent       |
|                  | <i>Start Mode</i>              | <b>2A</b> | Constant Current      |
|                  | <i>Start Ramp Time</i>         | <b>2D</b> | 5 seconds             |
|                  | <i>Current Limit</i>           | <b>2B</b> | 400%                  |
| Compressor Recip | <i>Motor Full Load Current</i> | <b>1A</b> | Model dependent       |
|                  | <i>Start Mode</i>              | <b>2A</b> | Constant Current      |
|                  | <i>Start Ramp Time</i>         | <b>2D</b> | 5 seconds             |
|                  | <i>Current Limit</i>           | <b>2B</b> | 450%                  |
| Conveyor         | <i>Motor Full Load Current</i> | <b>1A</b> | Model dependent       |
|                  | <i>Start Mode</i>              | <b>2A</b> | Constant Current      |
|                  | <i>Start Ramp Time</i>         | <b>2D</b> | 5 seconds             |
|                  | <i>Current Limit</i>           | <b>2B</b> | 400%                  |
|                  | <i>Stop Mode</i>               | <b>2H</b> | Adaptive Control      |
|                  | <i>Adaptive Stop Profile</i>   | <b>2K</b> | Constant Deceleration |
|                  | <i>Stop Time</i>               | <b>2I</b> | 10 seconds            |
| Crusher Rotary   | <i>Motor Full Load Current</i> | <b>1A</b> | Model dependent       |
|                  | <i>Start Mode</i>              | <b>2A</b> | Constant Current      |
|                  | <i>Start Ramp Time</i>         | <b>2D</b> | 10 seconds            |
|                  | <i>Current Limit</i>           | <b>2B</b> | 400%                  |
|                  | <i>Excess Start Time</i>       | <b>5A</b> | 30 seconds            |
|                  | <i>Locked Rotor Time</i>       | <b>1C</b> | 20 seconds            |
| Crusher Jaw      | <i>Motor Full Load Current</i> | <b>1A</b> | Model dependent       |
|                  | <i>Start Mode</i>              | <b>2A</b> | Constant Current      |
|                  | <i>Start Ramp Time</i>         | <b>2D</b> | 10 seconds            |
|                  | <i>Current Limit</i>           | <b>2B</b> | 450%                  |
|                  | <i>Excess Start Time</i>       | <b>5A</b> | 40 seconds            |
|                  | <i>Locked Rotor Time</i>       | <b>1C</b> | 30 seconds            |

## 8.6 Standard menu

The standard menu provides access to commonly used parameters. For parameter details, see *Parameter descriptions* on page 53.

**Table 8-3 Standard menu**

| Parameter Group            |   | Parameters                               | Default Value           |
|----------------------------|---|--|-------------------------|
| 1 - Primary Motor Settings | M | <b>1A</b> <i>Motor Full Load Current</i> | Model dependent         |
|                            | ← |  |                         |
| ∧∨                         |   |  |                         |
| 2 - Start/Stop Modes-1     | M | <b>2A</b> <i>Start Mode</i>              | Constant Current        |
|                            | ← | <b>2B</b> <i>Current Limit</i>           | 350%                    |
|                            |   | <b>2C</b> <i>Initial Current</i>         | 350%                    |
|                            |   | <b>2D</b> <i>Start Ramp Time</i>         | 00:10 (minutes:seconds) |
|                            |   | <b>2H</b> <i>Stop Mode</i>               | Coast To Stop           |
|                            |   | <b>2I</b> <i>Stop Time</i>               | 00:03 (minutes:seconds) |
|                            |   | <b>2O</b> <i>Auto-Start Type</i>         | Off                     |
|                            |   | <b>2P</b> <i>Auto-Start Time</i>         | 00:01 (hours:minutes)   |
|                            |   | <b>2Q</b> <i>Auto-Stop Type</i>          | Off                     |
|                            |   | <b>2R</b> <i>Auto-Stop Time</i>          | 00:01 (hours:minutes)   |
| ∧∨                         |   |  |                         |
| 3 - Digital Inputs         | M | <b>3A</b> <i>Input A Function</i>        | Starter Disable         |
|                            | ← | <b>3B</b> <i>Input A Name</i>            | Starter Disable         |
|                            |   | <b>3C</b> <i>Input A Trip</i>            | Always Active           |
|                            |   | <b>3D</b> <i>Input A Initial Delay</i>   | 00:00 (minutes:seconds) |
|                            |   | <b>3E</b> <i>Input A Trip Delay</i>      | 00:00 (minutes:seconds) |
|                            |   | <b>3F</b> <i>Input B Function</i>        | Input Trip (N/O)        |
|                            |   | <b>3G</b> <i>Input B Name</i>            | Input Trip              |
|                            |   | <b>3H</b> <i>Input B Trip</i>            | Always Active           |
|                            |   | <b>3I</b> <i>Input B Initial Delay</i>   | 00:00 (minutes:seconds) |
|                            |   | <b>3J</b> <i>Input B Trip Delay</i>      | 00:00 (minutes:seconds) |
| ∧∨                         |   |  |                         |
| 4 - Digital Outputs        | M | <b>4A</b> <i>Relay A Action</i>          | Main Contactor          |
|                            | ← | <b>4B</b> <i>Relay A On Delay</i>        | 00:00 (minutes:seconds) |
|                            |   | <b>4C</b> <i>Relay A Off Delay</i>       | 00:00 (minutes:seconds) |
|                            |   | <b>4D</b> <i>Relay B Action</i>          | Run                     |
|                            |   | <b>4E</b> <i>Relay B On Delay</i>        | 00:00 (minutes:seconds) |
|                            |   | <b>4F</b> <i>Relay B Off Delay</i>       | 00:00 (minutes:seconds) |
|                            |   | <b>4G</b> <i>Relay C Action</i>          | Trip                    |
|                            |   | <b>4H</b> <i>Relay C On Delay</i>        | 00:00 (minutes:seconds) |
|                            |   | <b>4I</b> <i>Relay C Off Delay</i>       | 00:00 (minutes:seconds) |
| ∧∨                         |   |  |                         |
| 5 - Protection Settings    | M | <b>5A</b> <i>Excess Start Time</i>       | 00:20 (minutes:seconds) |
|                            | ← | <b>5D</b> <i>Phase Sequence</i>          | Any Sequence            |
|                            |   | <b>5E</b> <i>Underpower</i>              | 20%                     |
|                            |   | <b>5F</b> <i>Overpower</i>               | 400%                    |
| ∧∨                         |   |  |                         |
| 6 - Protection Delays      | M | <b>6B</b> <i>Underpower Delay</i>        | 00:05 (minutes:seconds) |
|                            | ← | <b>6C</b> <i>Overpower Delay</i>         | 00:00 (minutes:seconds) |
| ∧∨                         |   |  |                         |
| 7 - Set Points             | M | <b>7A</b> <i>Low Current Flag</i>        | 50%                     |
|                            | ← | <b>7B</b> <i>High Current Flag</i>       | 100%                    |
|                            |   | <b>7C</b> <i>Motor Temperature Flag</i>  | 80%                     |
| ∧∨                         |   |  |                         |

| Parameter Group       |   | Parameters                                  | Default Value         |
|-----------------------|---|---|-----------------------|
| 9 - Display<br><br>∧∨ | M | <b>9A</b> <i>Languages</i>                  |                       |
|                       | ← | <b>9B</b> <i>User Screen - Top Left</i>     | Motor Current         |
|                       |   | <b>9C</b> <i>User Screen - Top Right</i>    | Motor pf              |
|                       |   | <b>9D</b> <i>User Screen - Bottom Left</i>  | Hours Run             |
|                       |   | <b>9E</b> <i>User Screen - Bottom Right</i> | kWh                   |
|                       |   | <b>9J</b> <i>F1 Button Action</i>           | Setup Auto-Start/Stop |
|                       |   | <b>9K</b> <i>F2 Button Action</i>           | None                  |
|                       |   | <b>9M</b> <i>Display A or kW</i>            | Current               |

## 8.7 Advanced menu

The Advanced Menu gives access to all the programmable parameters in the Digistart D3. See *Parameter descriptions* on page 53.

**Table 8-4 Advanced menu**

| Parameter Group                      |                                  | Parameters                               | Default Value           |
|--------------------------------------|----------------------------------|--|-------------------------|
| 1 - Primary Motor Settings<br><br>∧∨ | M                                | <b>1A</b> <i>Motor Full Load Current</i> | Model dependent         |
|                                      | ←                                | <b>1B</b> <i>Locked Rotor Current</i>    | 600%                    |
|                                      |                                  | <b>1C</b> <i>Locked Rotor Time</i>       | 00:10 (minutes:seconds) |
|                                      |                                  | <b>1D</b> <i>Motor Service Factor</i>    | 105%                    |
| 2 - Start/Stop Modes-1<br><br>∧∨     | M                                | <b>2A</b> <i>Start Mode</i>              | Constant Current        |
|                                      | ←                                | <b>2B</b> <i>Current Limit</i>           | 350%                    |
|                                      |                                  | <b>2C</b> <i>Initial Current</i>         | 350%                    |
|                                      |                                  | <b>2D</b> <i>Start Ramp Time</i>         | 00:10 (minutes:seconds) |
|                                      |                                  | <b>2E</b> <i>Adaptive Start Profile</i>  | Constant Acceleration   |
|                                      |                                  | <b>2F</b> <i>Kickstart Level</i>         | 500%                    |
|                                      |                                  | <b>2G</b> <i>Kickstart Time</i>          | 0 ms                    |
|                                      |                                  | <b>2H</b> <i>Stop Mode</i>               | Coast To Stop           |
|                                      |                                  | <b>2I</b> <i>Stop Time</i>               | 00:03(minutes:seconds)  |
|                                      |                                  | <b>2J</b> <i>Stop Delay</i>              | 00:00 (minutes:seconds) |
|                                      |                                  | <b>2K</b> <i>Adaptive Stop Profile</i>   | Constant Deceleration   |
|                                      |                                  | <b>2L</b> <i>Adaptive Control Gain</i>   | 75%                     |
|                                      |                                  | <b>2M</b> <i>Brake Torque</i>            | 20%                     |
|                                      |                                  | <b>2N</b> <i>Brake Time</i>              | 00:01 (minutes:seconds) |
|                                      |                                  | <b>2O</b> <i>Auto-Start Type</i>         | Off                     |
|                                      |                                  | <b>2P</b> <i>Auto-Start Time</i>         | 00:01 (hours:minutes)   |
|                                      | <b>2Q</b> <i>Auto-Stop Type</i>  | Off                                      |                         |
|                                      | <b>2R</b> <i>Auto-Stop Time</i>  | 00:01 (hours:minutes)                    |                         |
| 3 - Digital Inputs<br><br>∧∨         | M                                | <b>3A</b> <i>Input A Function</i>        | Starter Disable         |
|                                      | ←                                | <b>3B</b> <i>Input A Name</i>            | Starter Disable         |
|                                      |                                  | <b>3C</b> <i>Input A Trip</i>            | Always Active           |
|                                      |                                  | <b>3D</b> <i>Input A Initial Delay</i>   | 00:00 (minutes:seconds) |
|                                      |                                  | <b>3E</b> <i>Input A Trip Delay</i>      | 00:00 (minutes:seconds) |
|                                      |                                  | <b>3F</b> <i>Input B Function</i>        | Input Trip (N/O)        |
|                                      |                                  | <b>3G</b> <i>Input B Name</i>            | Input Trip              |
|                                      |                                  | <b>3H</b> <i>Input B Trip</i>            | Always Active           |
|                                      |                                  | <b>3I</b> <i>Input B Initial Delay</i>   | 00:00 (minutes:seconds) |
|                                      |                                  | <b>3J</b> <i>Input B Trip Delay</i>      | 00:00 (minutes:seconds) |
|                                      |                                  | <b>3K</b> <i>Input C Function</i>        | Off                     |
|                                      |                                  | <b>3L</b> <i>Input D Function</i>        | Off                     |
|                                      |                                  | <b>3M</b> <i>Local/Remote</i>            | LCL/RMT Anytime         |
|                                      |                                  | <b>3N</b> <i>Remote Reset Logic</i>      | Normally Closed         |
|                                      | <b>3O</b> <i>Comms in Remote</i> | Enable Control in RMT                    |                         |

| Parameter Group                 |                                   | Parameters                                   | Default Value                            |
|---------------------------------|-----------------------------------|--|--|
| 4 - Digital Outputs<br><br>∧∨   | M                                 | <b>4A</b> <i>Relay A Action</i>              | Main Contactor                           |
|                                 | ←                                 | <b>4B</b> <i>Relay A On Delay</i>            | 00:00 (minutes:seconds)                  |
|                                 |                                   | <b>4C</b> <i>Relay A Off Delay</i>           | 00:00 (minutes:seconds)                  |
|                                 |                                   | <b>4D</b> <i>Relay B Action</i>              | Run                                      |
|                                 |                                   | <b>4E</b> <i>Relay B On Delay</i>            | 00:00 (minutes:seconds)                  |
|                                 |                                   | <b>4F</b> <i>Relay B Off Delay</i>           | 00:00 (minutes:seconds)                  |
|                                 |                                   | <b>4G</b> <i>Relay C Action</i>              | Trip                                     |
|                                 |                                   | <b>4H</b> <i>Relay C On Delay</i>            | 00:00 (minutes:seconds)                  |
|                                 |                                   | <b>4I</b> <i>Relay C Off Delay</i>           | 00:00 (minutes:seconds)                  |
|                                 |                                   | <b>4J</b> <i>Relay D Action</i>              | Off                                      |
|                                 |                                   | <b>4K</b> <i>Relay E Action</i>              | Off                                      |
|                                 |                                   | <b>4L</b> <i>Relay F Action</i>              | Off                                      |
|                                 | 5 - Protection Settings<br><br>∧∨ | M  | <b>5A</b> <i>Excess Start Time</i>       |
| ←                               |                                   | <b>5B</b> <i>Excess Start Time-2</i>         | 00:20 (minutes:seconds)                  |
|                                 |                                   | <b>5C</b> <i>Current Imbalance</i>           | 30%                                      |
|                                 |                                   | <b>5D</b> <i>Phase Sequence</i>              | Any Sequence                             |
|                                 |                                   | <b>5E</b> <i>Underpower</i>                  | 20%                                      |
|                                 |                                   | <b>5F</b> <i>Overpower</i>                   | 400%                                     |
|                                 |                                   | <b>5G</b> <i>Reserved</i>                    | -  |
|                                 |                                   | <b>5H</b> <i>Reserved</i>                    | -  |
|                                 |                                   | <b>5I</b> <i>Frequency Check</i>             | Start/Run                                |
|                                 |                                   | <b>5J</b> <i>Frequency Variation</i>         | ±5 Hz                                    |
|                                 |                                   | <b>5K</b> <i>Ground Fault Level</i>          | 100 mA                                   |
|                                 |                                   | <b>5L</b> <i>Motor Temperature Check</i>     | Do Not Check                             |
| 6 - Protection Delays<br><br>∧∨ |                                   | M  | <b>6A</b> <i>Current Imbalance Delay</i> |
|                                 | ←                                 | <b>6B</b> <i>Underpower Delay</i>            | 00:05 (minutes:seconds)                  |
|                                 |                                   | <b>6C</b> <i>Overpower Delay</i>             | 00:00 (minutes:seconds)                  |
|                                 |                                   | <b>6D</b> <i>Reserved</i>                    | -  |
|                                 |                                   | <b>6E</b> <i>Reserved</i>                    | -  |
|                                 |                                   | <b>6F</b> <i>Frequency Delay</i>             | 00:01 (minutes:seconds)                  |
|                                 |                                   | <b>6G</b> <i>Restart Delay</i>               | 00:10 (minutes:seconds)                  |
|                                 |                                   | <b>6H</b> <i>Ground Fault Delay</i>          | 00:03 (minutes:seconds)                  |
|                                 |                                   |  |  |
| 7 - Set Points<br><br>∧∨        | M                                 | <b>7A</b> <i>Low Current Flag</i>            | 50%                                      |
|                                 | ←                                 | <b>7B</b> <i>High Current Flag</i>           | 100%                                     |
|                                 |                                   | <b>7C</b> <i>Motor Temperature Flag</i>      | 80%                                      |
|                                 |                                   | <b>7D</b> <i>Mains Reference Voltage</i>     | 400 V                                    |
| 8 - Analog I/O<br><br>∧∨        | M                                 | <b>8A</b> <i>Analog Input Trip</i>           | Do Not Trip                              |
|                                 | ←                                 | <b>8B</b> <i>Analog Input Scale</i>          | 2-10 V                                   |
|                                 |                                   | <b>8C</b> <i>Analog Trip Point</i>           | 50%                                      |
|                                 |                                   | <b>8D</b> <i>Analog Output A</i>             | Current (% FLC)                          |
|                                 |                                   | <b>8E</b> <i>Analog A Scale</i>              | 4-20 mA                                  |
|                                 |                                   | <b>8F</b> <i>Analog A Maximum Adjustment</i> | 100%                                     |
|                                 |                                   | <b>8G</b> <i>Analog A Minimum Adjustment</i> | 0%                                       |
|                                 |                                   | <b>8H</b> <i>Analog Output B</i>             | Current (% FLC)                          |
|                                 |                                   | <b>8I</b> <i>Analog B Scale</i>              | 4-20 mA                                  |
|                                 |                                   | <b>8J</b> <i>Analog B Maximum Adjustment</i> | 100%                                     |
|                                 |                                   | <b>8K</b> <i>Analog B Minimum Adjustment</i> | 0%                                       |

| Parameter Group                         |   | Parameters                                   | Default Value           |
|---|---|--|-------------------------|
| 9 - Display<br><br>^v                   | M | <b>9A</b> <i>Languages</i>                   |                         |
|   | ← | <b>9B</b> <i>User Screen - Top Left</i>      | Motor Current           |
|   |   | <b>9C</b> <i>User Screen - Top Right</i>     | Motor pf                |
|   |   | <b>9D</b> <i>User Screen - Bottom Left</i>   | Hours Run               |
|   |   | <b>9E</b> <i>User Screen - Bottom Right</i>  | kWh                     |
|   |   | <b>9F</b> <i>Graph Data</i>                  | Current (% FLC)         |
|   |   | <b>9G</b> <i>Graph Timebase</i>              | 10 seconds              |
|   |   | <b>9H</b> <i>Graph Maximum Adjustment</i>    | 400%                    |
|   |   | <b>9I</b> <i>Graph Minimum Adjustment</i>    | 0%                      |
|   |   | <b>9J</b> <i>F1 Button Action</i>            | Setup Auto-Start/Stop   |
|   |   | <b>9K</b> <i>F2 Button Action</i>            | None                    |
|   |   | <b>9L</b> <i>Current Calibration</i>         | 100%                    |
|   |   | <b>9M</b> <i>Display A or kW</i>             | Current                 |
| 10 - Auto-Reset<br><br>^v               | M | <b>10A</b> <i>Auto-Reset Action</i>          | Do Not Auto-Reset       |
|   | ← | <b>10B</b> <i>Maximum Resets</i>             | 1                       |
|   |   | <b>10C</b> <i>Reset Delay Groups A&amp;B</i> | 00:05 (minutes:seconds) |
|   |   | <b>10D</b> <i>Reset Delay Group C</i>        | 5 minutes               |
| 11 - Secondary Motor Settings<br><br>^v | M | <b>11A</b> <i>Motor FLC-2</i>                | Model dependent         |
|   | ← | <b>11B</b> <i>Dual Thermal Model</i>         | Single                  |
|   |   | <b>11C</b> <i>Locked Rotor Current-2</i>     | 600%                    |
|   |   | <b>11D</b> <i>Locked Rotor Time-2</i>        | 00:10 (minutes:seconds) |
|   |   | <b>11E</b> <i>Motor Service Factor-2</i>     | 105%                    |
| 12 - Start/Stop Modes-2<br><br>^v       | M | <b>12A</b> <i>Start Mode-2</i>               | Constant Current        |
|   | ← | <b>12B</b> <i>Current Limit-2</i>            | 350%                    |
|   |   | <b>12C</b> <i>Initial Current-2</i>          | 350%                    |
|   |   | <b>12D</b> <i>Start Ramp-2</i>               | 00:10 (minutes:seconds) |
|   |   | <b>12E</b> <i>Adaptive Start Profile-2</i>   | Constant Acceleration   |
|   |   | <b>12F</b> <i>Kickstart Level-2</i>          | 500%                    |
|   |   | <b>12G</b> <i>Kickstart Time-2</i>           | 0 ms                    |
|   |   | <b>12H</b> <i>Stop Mode-2</i>                | Coast To Stop           |
|   |   | <b>12I</b> <i>Stop Time-2</i>                | 00:03 (minutes:seconds) |
|   |   | <b>12J</b> <i>Stop Delay-2</i>               | 00:00(minutes:seconds)  |
|   |   | <b>12K</b> <i>Adaptive Stop Profile-2</i>    | Constant Deceleration   |
|   |   | <b>12L</b> <i>Adaptive Control Gain-2</i>    | 75%                     |
|   |   | <b>12M</b> <i>Brake Torque-2</i>             | 20%                     |
|   |   | <b>12N</b> <i>Brake Time-2</i>               | 00:01(minutes:seconds)  |
| 13 - Slip-Ring Motors<br><br>^v         | M | <b>13A</b> <i>Motor Data-1 Ramp</i>          | Single Ramp             |
|   | ← | <b>13B</b> <i>Motor Data-2 Ramp</i>          | Single Ramp             |
|   |   | <b>13C</b> <i>Slip Ring Retard</i>           | 50%                     |
|   |   | <b>13D</b> <i>Changeover Time</i>            | 150 ms                  |
| 14 - RTD/PT100<br><br>^v                | M | <b>14A</b> <i>RTD/PT100 A °C</i>             | 50 °C                   |
|   | ← | <b>14B</b> <i>RTD/PT100 B °C</i>             | 50 °C                   |
|   |   | <b>14C</b> <i>RTD/PT100 C °C</i>             | 50 °C                   |
|   |   | <b>14D</b> <i>RTD/PT100 D °C</i>             | 50 °C                   |
|   |   | <b>14E</b> <i>RTD/PT100 E °C</i>             | 50 °C                   |
|   |   | <b>14F</b> <i>RTD/PT100 F °C</i>             | 50 °C                   |
|   |   | <b>14G</b> <i>RTD/PT100 G °C</i>             | 50 °C                   |

| Parameter Group                  |                                     | Parameters                                 | Default Value        |
|----------------------------------|-------------------------------------|--|----------------------|
| 15 - Restricted<br><br>ΛV        | M                                   | <b>15A</b> <i>Access Code</i>              | 0000                 |
|                                  | ←                                   | <b>15B</b> <i>Emergency Run</i>            | Disable              |
|                                  |                                     | <b>15C</b> <i>Adjustment Lock</i>          | Read & Write         |
|                                  |                                     | <b>15D</b> <i>Shorted SCR Action</i>       | 3-Phase Control only |
|                                  |                                     | <b>15E</b> <i>Jog Torque</i>               | 50%                  |
| 16 - Protection Action<br><br>ΛV | M                                   | <b>16A</b> <i>Motor Overload</i>           | Trip Starter         |
|                                  | ←                                   | <b>16B</b> <i>Excess Start Time</i>        | Trip Starter         |
|                                  |                                     | <b>16C</b> <i>Current Imbalance</i>        | Trip Starter         |
|                                  |                                     | <b>16D</b> <i>Underpower</i>               | Trip Starter         |
|                                  |                                     | <b>16E</b> <i>Overpower</i>                | Trip Starter         |
|                                  |                                     | <b>16F</b> <i>Reserved</i>                 | -                    |
|                                  |                                     | <b>16G</b> <i>Reserved</i>                 | -                    |
|                                  |                                     | <b>16H</b> <i>Frequency</i>                | Trip Starter         |
|                                  |                                     | <b>16I</b> <i>Input A Trip</i>             | Trip Starter         |
|                                  |                                     | <b>16J</b> <i>Input B Trip</i>             | Trip Starter         |
|                                  |                                     | <b>16K</b> <i>Motor Thermistor</i>         | Trip Starter         |
|                                  |                                     | <b>16L</b> <i>Starter Communication</i>    | Trip Starter         |
|                                  |                                     | <b>16M</b> <i>Network Communication</i>    | Trip Starter         |
|                                  |                                     | <b>16N</b> <i>Heatsink Overtemperature</i> | Trip Starter         |
|                                  |                                     | <b>16O</b> <i>Battery/Clock</i>            | Trip Starter         |
|                                  |                                     | <b>16P</b> <i>Ground Fault</i>             | Trip Starter         |
|                                  |                                     | <b>16Q</b> <i>RTD/PT100 A</i>              | Trip Starter         |
|                                  |                                     | <b>16R</b> <i>RTD/PT100 B</i>              | Trip Starter         |
|                                  |                                     | <b>16S</b> <i>RTD/PT100 C</i>              | Trip Starter         |
|                                  |                                     | <b>16T</b> <i>RTD/PT100 D</i>              | Trip Starter         |
|                                  | <b>16U</b> <i>RTD/PT100 E</i>       | Trip Starter                               |                      |
|                                  | <b>16V</b> <i>RTD/PT100 F</i>       | Trip Starter                               |                      |
|                                  | <b>16W</b> <i>RTD/PT100 G</i>       | Trip Starter                               |                      |
|                                  | <b>16X</b> <i>Low Control Volts</i> | Trip Starter                               |                      |

## 8.8 Parameter descriptions

### 8.8.1 Notes on optional parameters

The following sections provide a description for all the parameters, whether available by default or optional. Optional parameters are only available if the relevant option card is fitted to the soft starter. For a detailed list of optional parameters, refer to the table below.

**Table 8-5 Optional parameters**

| No  | Function                    | Option card required  |
|-----|-----------------------------|---|
| 3K  | Input C Function            | <b>NOTE</b> Inputs C and D are only available if the input/output expansion card is installed.  |
| 3L  | Input D Function            |   |
| 4J  | Relay D Action              | <b>NOTE</b> Outputs D, E and F are only available if the input/output expansion card is installed.  |
| 4K  | Relay E Action              |   |
| 4L  | Relay F Action              |   |
| 5K  | Ground Fault Level          | <b>NOTE</b> Ground fault protection is only available if the RTD/PT100 and ground fault protection card is fitted.                        |
| 6H  | Ground Fault Delay          |   |
| 8A  | Analog Input Trip           | <b>NOTE</b> The analog input is only available if the input/output expansion card is installed.   |
| 8B  | Analog Input Scale          |   |
| 8C  | Analog Trip Point           |   |
| 8H  | Analog Output B             | <b>NOTE</b> Analog Output B is only available if the input/output expansion card is installed.  |
| 8I  | Analog B Scale              |   |
| 8J  | Analog B Maximum Adjustment |   |
| 8K  | Analog B Minimum Adjustment |   |
| 14B | RTD/PT100 B °C              | <b>NOTE</b> PT100 inputs B to G are only available if the RTD/PT100 and ground fault protection card has been installed.                  |
| 14C | RTD/PT100 C °C              |   |
| 14D | RTD/PT100 D °C              |   |
| 14E | RTD/PT100 E °C              |   |
| 14F | RTD/PT100 F °C              |   |
| 14G | RTD/PT100 G °C              |   |
| 16P | Ground Fault                | <b>NOTE</b> Ground Fault and PT100 inputs B to G are only available if the RTD/PT100 and ground fault protection card has been installed. |
| 16R | RTD/PT100 B                 |   |
| 16S | RTD/PT100 C                 |   |
| 16T | RTD/PT100 D                 |   |
| 16U | RTD/PT100 E                 |   |
| 16V | RTD/PT100 F                 |   |
| 16W | RTD/PT100 G                 |   |

### 8.8.2 Group 1 - Primary Motor Settings



The motor data parameters are critical to the correct operation of the soft starter's thermal model, and to the motor overload protection. Always set Pr **1A** to suit the motor's characteristics. The default settings of Pr **1B**, **1C** and **1D** are suitable for most applications. Consult the motor datasheet before changing these settings.

| No | Function                | Range           | Default         |
|----|-------------------------|-----------------|-----------------|
| 1A | Motor Full Load Current | Model dependent | Model dependent |

Matches the starter to the connected motor's full load current. Set to the full load current (FLC) rating shown on the motor nameplate.

When connecting in inside delta, enter the motor full load current (FLC) for Pr **1A**. The Digistart D3 will automatically detect whether the motor is connected in-line or inside delta and will calculate the correct inside delta current level.

| No | Function             | Range            | Default |
|----|----------------------|------------------|---------|
| 1B | Locked Rotor Current | 400 to 1200% FLC | 600%    |

Sets the locked rotor current of the connected motor, as a percentage of full load current. Set according to the motor datasheet.

|                    |             |                         |                         |                   |                           |           |                    |             |                      |                |             |         |
|--------------------|-------------|-------------------------|-------------------------|-------------------|---------------------------|-----------|--------------------|-------------|----------------------|----------------|-------------|---------|
| Safety Information | Rating Data | Mechanical Installation | Electrical Installation | Keypad and Status | Quick Start Commissioning | Operation | <b>Programming</b> | Diagnostics | Application Examples | Technical Data | Maintenance | Options |
|--------------------|-------------|-------------------------|-------------------------|-------------------|---------------------------|-----------|--------------------|-------------|----------------------|----------------|-------------|---------|

| No | Function                 | Range                            | Default |
|----|--------------------------|----------------------------------|---------|
| 1C | <i>Locked Rotor Time</i> | 00:01 to 02:00 (minutes:seconds) | 00:10   |

Sets the maximum length of time the motor can sustain locked rotor current from cold before reaching its maximum temperature. Set according to the motor datasheet.

| No | Function                    | Range           | Default |
|----|-----------------------------|-----------------|---------|
| 1D | <i>Motor Service Factor</i> | 100 to 130% FLC | 105%    |

Sets the motor service factor used by the thermal model. If the motor runs at full load current, it will reach 100%. Set according to the motor datasheet.

**NOTE** Pr 1B, 1C and 1D determine the trip current for motor overload protection. The default settings of Pr 1B, 1C and 1D provide Motor Overload Protection: Class 10, Trip Current 105% of FLA (full load amperage) or equivalent.

### 8.8.3 Group 2 - Start/Stop Modes-1

For details of soft start and stop control methods, see *Soft start methods* on page 38 and *Stop methods* on page 40.

| No | Function          | Range                              | Default          |
|----|-------------------|------------------------------------|------------------|
| 2A | <i>Start Mode</i> | Constant Current, Adaptive Control | Constant Current |

Selects the soft start mode.

| No | Function             | Range           | Default |
|----|----------------------|-----------------|---------|
| 2B | <i>Current Limit</i> | 100 to 600% FLC | 350%    |

Sets the current limit for constant current and current ramp soft starting, as a percentage of motor full load current.

| No | Function               | Range           | Default |
|----|------------------------|-----------------|---------|
| 2C | <i>Initial Current</i> | 100 to 600% FLC | 350%    |

Sets the initial start current level for current ramp starting, as a percentage of motor full load current. Set so that the motor begins to accelerate immediately after a start is initiated.

If current ramp starting is not required, set the initial current equal to the current limit.

| No | Function               | Range                            | Default |
|----|------------------------|----------------------------------|---------|
| 2D | <i>Start Ramp Time</i> | 00:01 to 03:00 (minutes:seconds) | 00:10   |

Sets the total start time for an Adaptive Control start or the ramp time for current ramp starting (from the initial current to the current limit).

| No | Function                      | Range  | Default               |
|----|-------------------------------|--|-----------------------|
| 2E | <i>Adaptive Start Profile</i> | Early Acceleration, Constant Acceleration, Late Acceleration | Constant Acceleration |

Selects which profile the Digistart D3 will use for an Adaptive Control soft start.

| No | Function               | Range           | Default |
|----|------------------------|-----------------|---------|
| 2F | <i>Kickstart Level</i> | 100 to 700% FLC | 500%    |

Sets the level of the kickstart current.

| No | Function              | Range        | Default |
|----|-----------------------|--------------|---------|
| 2G | <i>Kickstart Time</i> | 0 to 2000 ms | 0       |

Sets the kickstart duration. A setting of 0 disables kickstart.



Kickstart subjects the mechanical equipment to increased torque levels. Ensure the motor, load and couplings can handle the additional torque before using this feature.

| No | Function         | Range   | Default       |
|----|------------------|---|---------------|
| 2H | <i>Stop Mode</i> | Coast To Stop, TVR Soft Stop, Adaptive Control, Brake | Coast To Stop |

Selects the stop mode.



When using DC brake, the mains supply must be connected to the soft starter (input terminals L1, L2, L3) in positive phase sequence and Pr 5D *Phase Sequence* must be set to Positive Only.

| No | Function         | Range                            | Default |
|----|------------------|----------------------------------|---------|
| 2I | <i>Stop Time</i> | 00:00 to 04:00 (minutes:seconds) | 00:03   |

Sets the time for soft stopping the motor using timed voltage ramp or Adaptive Control. This also sets the total stopping time when using brake.

If a main contactor is installed, the contactor must remain closed until the end of the stop time. Use one of the programmable relays to control the main contactor.

| No | Function          | Range                            | Default |
|----|-------------------|----------------------------------|---------|
| 2J | <i>Stop Delay</i> | 00:00 to 01:00 (minutes:seconds) | 00:00   |

Sets a delay after the starter receives a stop command, before it stops the motor.

| No | Function                     | Range  | Default               |
|----|------------------------------|--|-----------------------|
| 2K | <i>Adaptive Stop Profile</i> | Early Deceleration, Constant Deceleration, Late Deceleration | Constant Deceleration |

Selects which profile the Digistart D3 will use for an Adaptive Control soft stop.

| No | Function                     | Range     | Default |
|----|------------------------------|-----------|---------|
| 2L | <i>Adaptive Control Gain</i> | 1 to 200% | 75%     |

Adjusts the performance of Adaptive Control. This setting affects both starting and stopping control.

**NOTE** We recommend leaving the gain setting at the default level unless performance is not satisfactory. If the motor accelerates or decelerates too quickly at the end of a start or stop, increase the gain setting by 5% to 10%. If the motor speed fluctuates during starting or stopping, decrease the gain setting slightly.

| No | Function            | Range      | Default |
|----|---------------------|------------|---------|
| 2M | <i>Brake Torque</i> | 20 to 100% | 20%     |

Sets the amount of brake torque the Digistart D3 will use to slow the motor.

| No | Function          | Range                            | Default |
|----|-------------------|----------------------------------|---------|
| 2N | <i>Brake Time</i> | 00:01 to 00:30 (minutes:seconds) | 00:01   |

Sets the duration for DC injection during a braking stop.

**NOTE** Pr 2N is used in conjunction with Pr 2I. See *Brake* on page 42 for details.

### Auto-start and auto-stop

The Digistart D3 can be programmed to start and stop automatically, after a specified delay or at a specified time of day. Auto-start and auto-stop can be set separately. Auto-start/stop is only available in Remote mode.



This function should not be used in conjunction with remote two-wire control. The soft starter will still accept start and stop commands from the remote inputs or serial communication network. To disable local or remote control, use Pr 3M. If auto-start is enabled and the user is in the menu system, auto-start will become active if the menu times out (if no keypad activity is detected for five minutes).

| No | Function               | Range             | Default |
|----|------------------------|-------------------|---------|
| 2O | <i>Auto-Start Type</i> | Off, Timer, Clock | Off     |

Selects whether the soft starter will auto-start after a specified delay, or at a time of day.

| No | Function               | Range                          | Default |
|----|------------------------|--------------------------------|---------|
| 2P | <i>Auto-Start Time</i> | 00:01 to 24:00 (hours:minutes) | 00:01   |

Sets the time for the soft starter to auto-start, in 24 hour clock format.

| No | Function              | Range             | Default |
|----|-----------------------|-------------------|---------|
| 2Q | <i>Auto-Stop Type</i> | Off, Timer, Clock | Off     |

Selects whether the soft starter will auto-stop after a specified delay, or at a time of day.

| No | Function              | Range                          | Default |
|----|-----------------------|--------------------------------|---------|
| 2R | <i>Auto-Stop Time</i> | 00:01 to 24:00 (hours:minutes) | 00:01   |

Sets the time for the soft starter to auto-stop, in 24 hour clock format.

### 8.8.4 Group 3 - Digital Inputs

The Digistart D3 has two programmable inputs, which allow remote control of the soft starter. If required, two extra inputs are available on the input/output expansion card.

| No | Function                | Range   | Default         |
|----|-------------------------|---|-----------------|
| 3A | <i>Input A Function</i> | Motor Set Select, Input Trip (N/O), Input Trip (N/C), Local/Remote Select, Emergency Run, Starter Disable, Jog Forward, Jog Reverse | Starter Disable |

Selects the function of Input A.

**Motor Set Select**

The Digistart D3 can be configured with two separate sets of motor data. To use the secondary motor data, Pr **3A** must be set to 'Motor Set Select' and DI4, +24V must be closed when a start command is given. The Digistart D3 checks which motor data to use at a start, and will use that motor data for the entire start/stop cycle.

**Input Trip (N/O)**

Input A can be used to trip the soft starter. When Pr **3A** is set to Input Trip (N/O), a closed circuit across DI4, +24V trips the soft starter.

**Input Trip (N/C)**

When Pr **3A** is set to Input Trip (N/C), an open circuit across DI4, +24V trips the soft starter.

**Local/Remote Select**

Input A can be used to select between local and remote control, instead of using the **LCL/RMT** button on the keypad. When the input is open, the starter is in local mode and can be controlled via the keypad. When the input is closed, the starter is in remote mode. The **START** and **LCL/RMT** buttons are disabled, and the soft starter will ignore any Local/Remote select command from the serial communications network.

To use Input A to select between local and remote control, Pr **3M** must be set to 'LCL/RMT Anytime' or 'LCL/RMT When Off'.

**Emergency Run**

In emergency run the soft starter continues to run until stopped, ignoring all trips and warnings (see Pr **15B** for details).

Closing the circuit across DI4, +24V activates emergency run.

Opening the circuit ends emergency run and the Digistart D3 stops the motor.

**Starter Disable**

The Digistart D3 can be disabled via the control inputs. An open circuit across DI4, +24V will disable the starter. The Digistart D3 will not respond to start commands. If running, the soft starter will allow the motor to coast to stop, ignoring the soft stop mode set in Pr **2H**.

**Jog Forward**

Activates jog operation in a forward direction (will operate only in Remote mode).

**Jog Reverse**

Activates jog operation in reverse direction (will operate only in Remote mode).

| No | Function            | Range  | Default         |
|----|---------------------|--|-----------------|
| 3B | <i>Input A Name</i> | Input Trip, Low Pressure, High Pressure, Pump Fault, Low Level, High Level, No Flow, Starter Disable, Controller, PLC, Vibration | Starter Disable |

Selects a message for the keypad to display when Input A is active. This text is only displayed if Pr **3A** is set to starter disable, or input trip (N/O or N/C).

| No | Function            | Range                                   | Default       |
|----|---------------------|---|---------------|
| 3C | <i>Input A Trip</i> | Always Active, Operating Only, Run Only | Always Active |

Selects when an input trip can occur.

**Always Active**

A trip can occur at any time when the soft starter is receiving power.

**Operating Only**

A trip can occur while the soft starter is running, stopping or starting.

**Run Only**

A trip can only occur while the soft starter is running.

| No | Function                     | Range                            | Default |
|----|------------------------------|----------------------------------|---------|
| 3D | <i>Input A Initial Delay</i> | 00:00 to 30:00 (minutes:seconds) | 00:00   |

Sets a delay before an input trip can occur. The initial delay is counted from the time a start signal is received. The state of the input is ignored until the initial delay has elapsed.

| No | Function                  | Range                            | Default |
|----|---------------------------|----------------------------------|---------|
| 3E | <i>Input A Trip Delay</i> | 00:00 to 04:00 (minutes:seconds) | 00:00   |

Sets a delay between the input activating and the soft starter tripping.

| No | Function                     | Range   | Default          |
|----|------------------------------|---|------------------|
| 3F | <i>Input B Function</i>      | Motor Set Select, Input Trip (N/O), Input Trip (N/C), Local/Remote Select, Emergency Run, Starter Disable, Jog Forward, Jog Reverse | Input Trip (N/O) |
| 3G | <i>Input B Name</i>          | Input Trip, Low Pressure, High Pressure, Pump Fault, Low Level, High Level, No Flow, Starter Disable, Controller, PLC, Vibration    | Input Trip       |
| 3H | <i>Input B Trip</i>          | Always Active, Operating Only, Run Only   | Always Active    |
| 3I | <i>Input B Initial Delay</i> | 00:00 to 30:00 (minutes:seconds)  | 00:00            |
| 3J | <i>Input B Trip Delay</i>    | 00:00 to 04:00 (minutes:seconds)  |                  |

See Pr **3A** to **3E** for details of parameter options.

| No | Function                | Range  | Default |
|----|-------------------------|--|---------|
| 3K | <i>Input C Function</i> | Motor Set Select, Local/Remote Select, Emergency Run, Starter Disable, Off | Off     |
| 3L | <i>Input D Function</i> |  |         |

See Pr **3A** for details of parameter options.

**NOTE** Inputs C and D are only available if the input/output expansion card is installed.

| No | Function            | Range  | Default         |
|----|---------------------|--|-----------------|
| 3M | <i>Local/Remote</i> | LCL/RMT Anytime, LCL/RMT When Off, Local Control Only, Remote Control Only | LCL/RMT Anytime |

Selects when the **LCL/RMT** button can be used to switch between local and remote control, and enables or disables the local control buttons and remote control inputs.

The **STOP** button on the keypad is always enabled.

|                            |  |
|----------------------------|--|
| <b>LCL/RMT Anytime</b>     | <b>LCL/RMT</b> button is always enabled.   |
| <b>LCL/RMT When Off</b>    | <b>LCL/RMT</b> button is enabled when the starter is off.                            |
| <b>Local Control Only</b>  | All remote inputs are disabled.  |
| <b>Remote Control Only</b> | Local control buttons ( <b>START</b> , <b>RESET</b> , <b>LCL/RMT</b> ) are disabled. |



The **STOP** button on the keypad is always enabled. When using two-wire remote control, the soft starter will restart if the remote start/stop and reset inputs are still active.

| No | Function                  | Range                                      | Default               |
|----|---------------------------|--|-----------------------|
| 3N | <i>Remote Reset Logic</i> | Normally Closed (N/C), Normally Open (N/O) | Normally Closed (N/C) |

Selects whether the Digistart D3's remote reset input (terminals DI3, +24V) is normally open or normally closed.

| No | Function               | Range   | Default               |
|----|------------------------|---|-----------------------|
| 3O | <i>Comms in Remote</i> | Disable Control in RMT, Enable Control in RMT | Enable Control in RMT |

Selects whether the starter will accept Start and Stop commands from the serial communication network when in Remote mode. The Reset, Force Comms Trip and Local/Remote Control commands are always enabled.

### 8.8.5 Group 4 - Digital Outputs

The Digistart D3 has three programmable outputs, which can be used to signal different operating conditions to associated equipment. Three additional outputs are available on the input/output expansion card.

| No | Function              | Range   | Default        |
|----|-----------------------|---|----------------|
| 4A | <i>Relay A Action</i> | Off, Main Contactor, Run, Trip, Warning, Low Current Flag, High Current Flag, Motor Temperature Flag, Input A Trip, Input B Trip, Motor Overload, Current Imbalance, Underpower, Overpower, Frequency, Ground Fault, Heatsink Overtemperature, Phase Loss, Motor Thermistor, Changeover Contactor | Main Contactor |

Selects the function of Relay A (normally open). Relay A is terminals COM1, RLO1.

|                                 |  |
|---------------------------------|--|
| <b>Off</b>                      | Relay A is not used.   |
| <b>Main Contactor</b>           | The relay closes when the Digistart D3 receives a start command, and remains closed as long as the motor is receiving voltage. |
| <b>Run</b>                      | The relay closes when the starter changes to run state.  |
| <b>Trip</b>                     | The relay closes when the starter trips (see Pr <b>16A</b> to <b>16X</b> ).  |
| <b>Warning</b>                  | The relay closes when the starter issues a warning (see Pr <b>16A</b> to <b>16X</b> ).   |
| <b>Low Current Flag</b>         | The relay closes when the low current flag activates (see Pr <b>7A Low Current Flag</b> , while the motor is running).         |
| <b>High Current Flag</b>        | The relay closes when the high current flag activates (see Pr <b>7B High Current Flag</b> , while the motor is running).       |
| <b>Motor Temperature Flag</b>   | The relay closes when the motor temperature flag activates (see Pr <b>7C Motor Temperature Flag</b> ).                         |
| <b>Input A Trip</b>             | The relay closes when Input A activates to trip the soft starter.  |
| <b>Input B Trip</b>             | The relay closes when Input B activates to trip the soft starter.  |
| <b>Motor Overload</b>           | The relay closes when the starter trips on Motor Overload.   |
| <b>Current Imbalance</b>        | The relay closes when the starter trips on Current Imbalance.  |
| <b>Underpower</b>               | The relay closes when the starter trips on Underpower.   |
| <b>Overpower</b>                | The relay closes when the starter trips on Overpower.  |
| <b>Frequency</b>                | The relay closes when the starter trips on Frequency.  |
| <b>Ground Fault</b>             | The relay closes when the starter trips on Ground Fault.   |
| <b>Heatsink Overtemperature</b> | The relay closes when the starter trips on Heatsink Overtemperature.   |
| <b>Phase Loss</b>               | The relay closes when the starter trips on Phase Loss.   |
| <b>Motor Thermistor</b>         | The relay closes when the starter trips on Motor Thermistor.   |
| <b>Changeover Contactor</b>     | The relay closes when the high rotor resistance current ramp has reached full voltage, allowing use with a slip-ring motor.    |

| No | Function                 | Range                            | Default |
|----|--------------------------|----------------------------------|---------|
| 4B | <i>Relay A On Delay</i>  | 00:00 to 05:00 (minutes:seconds) | 00:00   |
| 4C | <i>Relay A Off Delay</i> |                                  |         |

Sets the delay for closing or re-opening Relay A.

| No | Function                 | Range   | Default |
|----|--------------------------|---|---------|
| 4D | <i>Relay B Action</i>    | Off, Main Contactor, Run, Trip, Warning, Low Current Flag, High Current Flag, Motor Temperature Flag, Input A Trip, Input B Trip, Motor Overload, Current Imbalance, Underpower, Overpower, Frequency, Ground Fault, Heatsink Overtemperature, Phase Loss, Motor Thermistor, Changeover Contactor | Run     |
| 4E | <i>Relay B On Delay</i>  | 00:00 to 05:00 (minutes:seconds)  | 00:00   |
| 4F | <i>Relay B Off Delay</i> |   |         |

See Pr **4A** to **4C** for details of parameter options.

| No | Function                 | Range   | Default |
|----|--------------------------|---|---------|
| 4G | <i>Relay C Action</i>    | Off, Main Contactor, Run, Trip, Warning, Low Current Flag, High Current Flag, Motor Temperature Flag, Input A Trip, Input B Trip, Motor Overload, Current Imbalance, Underpower, Overpower, Frequency, Ground Fault, Heatsink Overtemperature, Phase Loss, Motor Thermistor, Changeover Contactor | Trip    |
| 4H | <i>Relay C On Delay</i>  | 00:00 to 05:00 (minutes:seconds)  | 00:00   |
| 4I | <i>Relay C Off Delay</i> |   |         |

See Pr **4A** to **4C** for details of parameter options.

| No | Function              | Range   | Default |
|----|-----------------------|---|---------|
| 4J | <i>Relay D Action</i> | Off, Main Contactor, Run, Trip, Warning, Low Current Flag, High Current Flag, Motor Temperature Flag, Input A Trip, Input B Trip, Motor Overload, Current Imbalance, Underpower, Overpower, Frequency, Ground Fault, Heatsink Overtemperature, Phase Loss, Motor Thermistor, Changeover Contactor | Off     |
| 4K | <i>Relay E Action</i> |   |         |
| 4L | <i>Relay F Action</i> |   |         |

See Pr **4A** for details of parameter options.

**NOTE** Outputs D, E and F are only available if the input/output expansion card is installed.

### 8.8.6 Group 5 - Protection Settings

These parameters determine when the soft starter's protection mechanisms will activate. The activation point for each protection mechanism can be set to suit the installation.

The soft starter responds to protection events by tripping, warning, or writing the event to the event log. The response is determined by the Protection Action settings. The default response is a trip.



The protection settings are vital for safe operation of the soft starter and motor. Defeating the protection may compromise the installation and should only be done in the case of emergency.

| No | Function                   | Range                            | Default |
|----|----------------------------|----------------------------------|---------|
| 5A | <i>Excess Start Time</i>   | 00:00 to 04:00 (minutes:seconds) | 00:20   |
| 5B | <i>Excess Start Time-2</i> |                                  |         |

Excess start time is the maximum time the Digistart D3 will attempt to start the motor. If the motor does not transition to Run mode within the programmed limit, the starter will trip. Set for a period slightly longer than required for a normal healthy start. A setting of 0 disables excess start time protection.

Pr **5A** sets the time for the primary motor and Pr **5B** sets the time for the secondary motor.

| No | Function                 | Range     | Default |
|----|--------------------------|-----------|---------|
| 5C | <i>Current Imbalance</i> | 10 to 50% | 30%     |

Sets the trip point for current imbalance protection.

The Digistart D3 can be configured to trip if the currents on the three phases vary from each other by more than a specified amount. The imbalance is calculated as the difference between the highest and lowest currents on all three phases, as a percentage of the highest current.

Current imbalance detection is desensitised by 50% during starting and soft stopping.

| No | Function              | Range                                      | Default      |
|----|-----------------------|--|--------------|
| 5D | <i>Phase Sequence</i> | Any Sequence, Positive Only, Negative Only | Any Sequence |

Selects which phase sequences the soft starter will allow at a start. During its pre-start checks, the starter examines the sequence of the phases at its input terminals and trips if the actual sequence does not match the selected option.

| No | Function          | Range     | Default |
|----|-------------------|-----------|---------|
| 5E | <i>Underpower</i> | 0 to 100% | 20%     |

Sets the trip point for underpower protection. Set as required.

| No | Function         | Range      | Default |
|----|------------------|------------|---------|
| 5F | <i>Overpower</i> | 80 to 600% | 400%    |

Sets the trip point for overpower protection. Set as required.

| No | Function        | Range | Default |
|----|-----------------|-------|---------|
| 5G | <i>Reserved</i> | n/a   | n/a     |

This parameter is reserved for internal use.

| No | Function        | Range | Default |
|----|-----------------|-------|---------|
| 5H | <i>Reserved</i> | n/a   | n/a     |

This parameter is reserved for internal use.

| No | Function               | Range   | Default   |
|----|------------------------|---|-----------|
| 5I | <i>Frequency Check</i> | Do Not Check, Start Only, Start/Run, Run Only | Start/Run |

Determines when and if the starter will monitor for a frequency trip.

| No | Function                   | Range               | Default |
|----|----------------------------|---------------------|---------|
| 5J | <i>Frequency Variation</i> | ±2, ±5, ±10, ±15 Hz | ±5 Hz   |

Selects the soft starter's tolerance for frequency variation.



Running a motor outside its specified frequency for long periods can cause damage and premature failure.

| No | Function                  | Range   | Default |
|----|---------------------------|---|---------|
| 5K | <i>Ground Fault Level</i> | 20mA, 30mA, 50mA, 75mA, 100mA, 150mA, 200mA, 300mA, 500mA, 750mA, 1A, 1.5A, 2A, 3A, 5A, 7.5A, 10A, 15A, 20A, 30A, 50A | 100mA   |

Sets the trip point for ground fault protection.

The Digistart D3 can be configured to trip if ground fault exceeds a specified level while the motor is running. Ground fault is a dynamic trip based on phase current measurements every half-cycle.

**NOTE** Ground fault protection is only available if the RTD/PT100 and ground fault protection card is fitted.

| No | Function                       | Range               | Default      |
|----|--------------------------------|---------------------|--------------|
| 5L | <i>Motor Temperature Check</i> | Do Not Check, Check | Do Not Check |

Selects whether the Digistart D3 will verify the motor has sufficient thermal capacity for a successful start. The soft starter compares the motor's calculated temperature with the temperature rise from the last motor start and only operates if the motor is cool enough to start successfully.

### 8.8.7 Group 6 - Protection Delays

Protection delays slows the Digistart D3's response to the trip condition, avoiding trips due to momentary fluctuations.

| No | Function                       | Range                            | Default |
|----|--------------------------------|----------------------------------|---------|
| 6A | <i>Current Imbalance Delay</i> | 00:00 to 04:00 (minutes:seconds) | 00:03   |
| 6B | <i>Underpower Delay</i>        | 00:00 to 04:00 (minutes:seconds) | 00:05   |
| 6C | <i>Overpower Delay</i>         | 00:00 to 01:00 (minutes:seconds) | 00:00   |
| 6D | <i>Reserved</i>                | -                                | -       |
| 6E | <i>Reserved</i>                | -                                | -       |
| 6F | <i>Frequency Delay</i>         | 00:00 to 04:00 (minutes:seconds) | 00:01   |

| No | Function             | Range                            | Default |
|----|----------------------|----------------------------------|---------|
| 6G | <i>Restart Delay</i> | 00:01 to 60:00 (minutes:seconds) | 00:10   |

The Digistart D3 can be configured to force a delay between the end of a stop and the beginning of the next start. During the restart delay period, the display shows the time remaining before another start can be attempted.

| No | Function                  | Range                            | Default |
|----|---------------------------|----------------------------------|---------|
| 6H | <i>Ground Fault Delay</i> | 00:01 to 04:00 (minutes:seconds) | 00:03   |

**NOTE** Ground fault protection is only available if the RTD/PT100 and ground fault protection card is fitted.

|                    |             |                         |                         |                   |                           |           |                    |             |                      |                |             |         |
|--------------------|-------------|-------------------------|-------------------------|-------------------|---------------------------|-----------|--------------------|-------------|----------------------|----------------|-------------|---------|
| Safety Information | Rating Data | Mechanical Installation | Electrical Installation | Keypad and Status | Quick Start Commissioning | Operation | <b>Programming</b> | Diagnostics | Application Examples | Technical Data | Maintenance | Options |
|--------------------|-------------|-------------------------|-------------------------|-------------------|---------------------------|-----------|--------------------|-------------|----------------------|----------------|-------------|---------|

### 8.8.8 Group 7 - Set Points

The Digistart D3 has low and high current flags to give early warning of abnormal operation.

| No | Function                 | Range           | Default |
|----|--------------------------|-----------------|---------|
| 7A | <i>Low Current Flag</i>  | 1% to 100% FLC  | 50%     |
| 7B | <i>High Current Flag</i> | 50% to 600% FLC | 100%    |

The current flags can be configured to indicate an abnormal current level during operation, outside the normal operating level. The flags can signal the situation to external equipment via one of the programmable outputs. The flags clear when the current returns within the normal operating range by 10% of the programmed motor full load current.

| No | Function                      | Range      | Default |
|----|-------------------------------|------------|---------|
| 7C | <i>Motor Temperature Flag</i> | 0% to 160% | 80%     |

Sets the level at which the motor temperature flag operates, as a percentage of the motor's thermal capacity.

| No | Function                       | Range          | Default |
|----|--------------------------------|----------------|---------|
| 7D | <i>Mains Reference Voltage</i> | 100 V to 690 V | 400 V   |

Sets the nominal mains voltage for the keypad's monitoring functions. This is used to calculate motor kilowatts and kilovolt amperes (kVA) but does not affect the Digistart D3's motor control or protection.

### 8.8.9 Group 8 - Analog I/O

The Digistart D3 has one analog output (terminals AO1, 0V).

If required, a second analog output and an analog input are available on the input/output expansion card.

| No | Function                 | Range                            | Default     |
|----|--------------------------|----------------------------------|-------------|
| 8A | <i>Analog Input Trip</i> | Do Not Trip, Trip High, Trip Low | Do Not Trip |

Selects the soft starter's response to the analog input signal. The soft starter can be configured to trip if the voltage measured at the analog input falls below or rises above the level set in Pr **8C Analog Trip Point** (as a percentage of the maximum value of Pr **8B Analog Input Scale**).

| No | Function                  | Range        | Default |
|----|---------------------------|--------------|---------|
| 8B | <i>Analog Input Scale</i> | 0-10, 2-10 V | 2-10 V  |

Selects the scale of the analog input.

| No | Function                 | Range     | Default |
|----|--------------------------|-----------|---------|
| 8C | <i>Analog Trip Point</i> | 0 to 100% | 50%     |

Sets the signal level at which an analog input trip will occur, as a percentage of the maximum signal on the input.

**NOTE** The analog input is only available if the input/output expansion card is installed.

| No | Function               | Range  | Default         |
|----|------------------------|--|-----------------|
| 8D | <i>Analog Output A</i> | Current (% FLC), Motor Temp (%), Motor kW (%), Motor kVA (%), Motor pf | Current (% FLC) |

Selects which information will be reported via the analog output.

|                        |  |
|------------------------|--|
| <b>Current (% FLC)</b> | Current as a percentage of motor full load current.  |
| <b>Motor Temp (%)</b>  | Motor temperature as a percentage of the motor service factor (calculated by the soft starter's thermal model).  |
| <b>Motor kW (%)</b>    | Motor kilowatts. 100% is motor FLC (Pr <b>1A</b> ) multiplied by line voltage (reference voltage parameter <b>7D</b> ). Power factor is assumed to be 1.0.<br>$\frac{\sqrt{3} \cdot V \cdot I_{FLC} \cdot pf}{1000}$ |
| <b>Motor kVA (%)</b>   | Motor kilovolt amperes. 100% is motor FLC (Pr <b>1A</b> ) multiplied by line voltage (reference voltage parameter <b>7D</b> ).<br>$\frac{\sqrt{3} \cdot V \cdot I_{FLC}}{1000}$                                      |
| <b>Motor pf</b>        | Motor power factor, measured by the soft starter.  |

| No | Function              | Range         | Default |
|----|-----------------------|---------------|---------|
| 8E | <i>Analog A Scale</i> | 0-20, 4-20 mA | 4-20 mA |

Selects the range of the analog output.

| No | Function                           | Range     | Default |
|----|------------------------------------|-----------|---------|
| 8F | <i>Analog A Maximum Adjustment</i> | 0 to 600% | 100%    |
| 8G | <i>Analog A Minimum Adjustment</i> |           | 0%      |

Calibrates the analog output to match the signal measured on an external current measuring device.

|                    |             |                         |                         |                   |                           |           |                    |             |                      |                |             |         |
|--------------------|-------------|-------------------------|-------------------------|-------------------|---------------------------|-----------|--------------------|-------------|----------------------|----------------|-------------|---------|
| Safety Information | Rating Data | Mechanical Installation | Electrical Installation | Keypad and Status | Quick Start Commissioning | Operation | <b>Programming</b> | Diagnostics | Application Examples | Technical Data | Maintenance | Options |
|--------------------|-------------|-------------------------|-------------------------|-------------------|---------------------------|-----------|--------------------|-------------|----------------------|----------------|-------------|---------|

| No | Function                           | Range  | Default         |
|----|------------------------------------|--|-----------------|
| 8H | <i>Analog Output B</i>             | Current (% FLC), Motor Temp (%), Motor kW (%), Motor kVA (%), Motor pf, Voltage (%Mains) | Current (% FLC) |
| 8I | <i>Analog B Scale</i>              | 0-20, 4-20 mA  | 4-20 mA         |
| 8J | <i>Analog B Maximum Adjustment</i> | 0 to 600%  | 100%            |
| 8K | <i>Analog B Minimum Adjustment</i> |  | 0%              |

See Pr **8D** to **8G** for details of parameter options.

**NOTE** Analog Output B is only available if the input/output expansion card is installed.

### 8.8.10 Group 9 - Display

| No | Function         | Range  | Default |
|----|------------------|--|---------|
| 9A | <i>Languages</i> | English, Français, Italiano, Deutsch, Español, Chinese |         |

Selects which language the keypad will use to display messages and feedback.

| No | Function                      | Range  | Default       |
|----|-------------------------------|--|---------------|
| 9B | <i>User Screen - Top Left</i> | Blank, Starter State, Motor Current, Motor pf, Mains Frequency, Motor kW, Motor HP, Motor Temp, kWh, Hours Run, Analog Input, Motor kVA, % Rated kW, Motor Parameter Set | Motor Current |

Selects which information will be displayed on the programmable monitoring screen.

|                            |   |
|----------------------------|---|
| <b>Blank</b>               | Displays no data in the selected area, allowing long messages to be shown without overlapping.  |
| <b>Starter State</b>       | The starter's operating state (starting, running, stopping or tripped). Only available for top left and bottom left positions on the screen.    |
| <b>Motor Current</b>       | The average current measured on three phases.   |
| <b>Motor pf</b>            | The motor's power factor, measured by the soft starter.   |
| <b>Mains Frequency</b>     | The average frequency measured on three phases.   |
| <b>Motor kW</b>            | The motor's running power in kilowatts.   |
| <b>Motor HP</b>            | The motor's running power in horsepower.  |
| <b>Motor Temp</b>          | The motor's temperature, calculated by the thermal model.   |
| <b>kWh</b>                 | The number of kilowatt hours the motor has run via the soft starter.  |
| <b>Hours Run</b>           | The number of hours the motor has run via the soft starter.   |
| <b>Analog Input</b>        | The level of analog input A (see Pr <b>8A</b> to <b>8C</b> ). This setting is only available if the input/output expansion option is installed. |
| <b>Motor kVA</b>           | The motor's apparent running power in kVA.  |
| <b>% Rated kW</b>          | The motor's running power as a percentage of rated kW. Power factor is assumed to be 1.0 at 100% kW.  |
| <b>Motor Parameter Set</b> | Whether the starter is controlling the motor using the primary motor set (M1) or the secondary motor set (M2).                                  |

| No | Function                          | Range   | Default         |
|----|-----------------------------------|---|-----------------|
| 9C | <i>User Screen - Top Right</i>    | Blank, Motor Current, Motor pf, Mains Frequency, Motor kW, Motor HP, Motor Temp, kWh, Hours Run, Analog Input, Motor kVA, % Rated kW                | Motor pf        |
| 9D | <i>User Screen - Bottom Left</i>  | Blank, Starter State, Motor Current, Motor pf, Mains Frequency, Motor kW, Motor HP, Motor Temp, kWh, Hours Run, Analog Input, Motor kVA, % Rated kW | Hours Run       |
| 9E | <i>User Screen - Bottom Right</i> | Blank, Motor Current, Motor pf, Mains Frequency, Motor kW, Motor HP, Motor Temp, kWh, Hours Run, Analog Input, Motor kVA, % Rated kW                | kWh             |
| No | Function                          | Range   | Default         |
| 9F | <i>Graph Data</i>                 | Current (% FLC), Motor Temp (%), Motor kW (%), Motor kVA (%), Motor pf  | Current (% FLC) |

Selects which information the graph will display. See Pr **8D** for details of parameter options.

|                    |             |                         |                         |                   |                           |           |                    |             |                      |                |             |         |
|--------------------|-------------|-------------------------|-------------------------|-------------------|---------------------------|-----------|--------------------|-------------|----------------------|----------------|-------------|---------|
| Safety Information | Rating Data | Mechanical Installation | Electrical Installation | Keypad and Status | Quick Start Commissioning | Operation | <b>Programming</b> | Diagnostics | Application Examples | Technical Data | Maintenance | Options |
|--------------------|-------------|-------------------------|-------------------------|-------------------|---------------------------|-----------|--------------------|-------------|----------------------|----------------|-------------|---------|

| No | Function              | Range   | Default    |
|----|-----------------------|---|------------|
| 9G | <i>Graph Timebase</i> | 10 seconds, 30 seconds, 1 minute, 5 minutes, 10 minutes, 30 minutes, 1 hour | 10 seconds |

Sets the graph time scale. The graph will progressively replace the old data with new data.

| No | Function                        | Range     | Default |
|----|---------------------------------|-----------|---------|
| 9H | <i>Graph Maximum Adjustment</i> | 0 to 600% | 400%    |
| 9I | <i>Graph Minimum Adjustment</i> |           | 0%      |

Adjusts the upper and lower limits of the performance graph.

| No | Function                | Range   | Default               |
|----|-------------------------|---|-----------------------|
| 9J | <i>F1 Button Action</i> | None, Setup Auto-Start/Stop<br>Jog Forward, Jog Reverse | Setup Auto-Start/Stop |
| 9K | <i>F2 Button Action</i> |   | None                  |

Selects the function of the shortcut buttons on the keypad.

**NOTE** If the adjustment lock is on (Pr 15C *Adjustment Lock* is set to Read Only), users will not be able to change the auto-start/stop settings.

| No | Function                   | Range      | Default |
|----|----------------------------|------------|---------|
| 9L | <i>Current Calibration</i> | 80 to 115% | 100%    |

Calibrates the soft starter's current monitoring circuits to match an external current metering device.

$$\text{Calibration (\%)} = \frac{\text{Current shown on Digistart D3 display}}{\text{Current measured by external device}}$$

$$\text{eg } 102\% = \frac{66\text{A}}{65\text{A}}$$

This adjustment affects all current-based functions and protections.

**NOTE**

| No | Function               | Range             | Default |
|----|------------------------|-------------------|---------|
| 9M | <i>Display A or kW</i> | Current, Motor kW | Current |

Selects whether the Digistart D3 will display current (amperes) or motor kilowatts on the main monitoring screen.

### 8.8.11 Group 10 - Auto-Reset

The Digistart D3 can be programmed to automatically reset certain trips, which can help minimise operating downtime. Trips are divided into three categories for auto-reset, depending on the risk to the soft starter:

**Table 8-6 Auto-reset groups**

| Group    | Trips   |
|----------|---|
| <b>A</b> | Current imbalance<br>Phase loss<br>Power loss<br>Frequency                                    |
| <b>B</b> | Underpower<br>Overpower<br>Input A trip<br>Input B trip                                       |
| <b>C</b> | Motor overload<br>RTD/PT100 temperature trips<br>Motor thermistor<br>Heatsink overtemperature |

Other trips cannot be automatically reset.

| No  | Function                 | Range   | Default           |
|-----|--------------------------|---|-------------------|
| 10A | <i>Auto-Reset Action</i> | Do Not Auto-Reset, Reset Group A, Reset Group A & B, Reset Group A, B & C | Do Not Auto-Reset |

Selects which trips can be auto-reset.

| No  | Function              | Range  | Default |
|-----|-----------------------|--------|---------|
| 10B | <i>Maximum Resets</i> | 1 to 5 | 1       |

Sets how many times the soft starter will auto-reset, if it continues to trip. The reset counter increases by one each time the soft starter auto-resets, and decreases by one after each successful start/stop cycle.

|                    |             |                         |                         |                   |                           |           |                    |             |                      |                |             |         |
|--------------------|-------------|-------------------------|-------------------------|-------------------|---------------------------|-----------|--------------------|-------------|----------------------|----------------|-------------|---------|
| Safety Information | Rating Data | Mechanical Installation | Electrical Installation | Keypad and Status | Quick Start Commissioning | Operation | <b>Programming</b> | Diagnostics | Application Examples | Technical Data | Maintenance | Options |
|--------------------|-------------|-------------------------|-------------------------|-------------------|---------------------------|-----------|--------------------|-------------|----------------------|----------------|-------------|---------|

| No  | Function                          | Range                            | Default |
|-----|-----------------------------------|----------------------------------|---------|
| 10C | <i>Reset Delay Groups A&amp;B</i> | 00:05 to 15:00 (minutes:seconds) | 00:05   |
| 10D | <i>Reset Delay Group C</i>        | 5 to 60 minutes                  | 5       |

The Digistart D3 can be configured to wait before auto-resetting a trip. Separate delays can be set for trips in Groups A and B, or in Group C.

### 8.8.12 Group 11 - Secondary Motor Settings

The Digistart D3 can support two different starting and stopping motor data sets.

- To use the Digistart D3 with two separate motors (such as a duty-standby configuration), use Pr **11B** to select dual thermal modelling and configure Pr **11A** to **12N** to suit the second motor.
- To use the Digistart D3 with two different motor data sets for the same motor (for dual speed motors or applications where starting conditions may vary), use Pr **11B** to select a single thermal model, and configure the starting and stopping profiles as required in Pr **12A** to **12N**. The soft starter will ignore Pr **11A** to **11E** and will use settings from the primary motor.

To select the secondary motor data set, a programmable input must be configured to parameter set selection (Pr **3A** and **3F**) and the input must be active when the soft starter receives a start signal.

For details of parameter options, see *Group 1 - Primary Motor Settings* on page 53.

**NOTE** You can only choose which motor data set to use while the soft starter is stopped.

| No  | Function           | Range           | Default         |
|-----|--------------------|-----------------|-----------------|
| 11A | <i>Motor FLC-2</i> | Model dependent | Model dependent |

Sets the secondary motor's full load current.

| No  | Function                  | Range        | Default |
|-----|---------------------------|--------------|---------|
| 11B | <i>Dual Thermal Model</i> | Single, Dual | Single  |

Activates dual thermal modelling. The dual thermal model is required only if the Digistart D3 is controlling two physically separate motors.

**NOTE** The second thermal model is only active if Pr **11B** *Dual Thermal Model* is set to 'Dual' and the starter is using the secondary motor set (a programmable input is set to 'Motor Set Select' and the input is active).

| No  | Function                      | Range                            | Default |
|-----|-------------------------------|----------------------------------|---------|
| 11C | <i>Locked Rotor Current-2</i> | 400 to 1200% FLC                 | 600%    |
| 11D | <i>Locked Rotor Time-2</i>    | 00:01 to 02:00 (minutes:seconds) | 00:10   |
| 11E | <i>Motor Service Factor-2</i> | 100 to 130%                      | 105%    |

### 8.8.13 Group 12 - Start/Stop Modes-2

For details of soft start and stop control methods, see *Soft start methods* on page 38 and *Stop methods* on page 40.

For details of parameter options, see *Group 2 - Start/Stop Modes-1* on page 54.

| No  | Function                        | Range  | Default               |
|-----|---------------------------------|--|-----------------------|
| 12A | <i>Start Mode-2</i>             | Constant Current, Adaptive Control                           | Constant Current      |
| 12B | <i>Current Limit-2</i>          | 100 to 600%  | 350%                  |
| 12C | <i>Initial Current-2</i>        | 100 to 600%  | 350%                  |
| 12D | <i>Start Ramp-2</i>             | 00:01 to 03:00 (minutes:seconds)                             | 00:10                 |
| 12E | <i>Adaptive Start Profile-2</i> | Early Acceleration, Constant Acceleration, Late Acceleration | Constant Acceleration |
| 12F | <i>Kickstart Level-2</i>        | 100 to 700% FLC  | 500%                  |
| 12G | <i>Kickstart Time-2</i>         | 0 to 2000 ms   | 0 ms                  |
| 12H | <i>Stop Mode-2</i>              | Coast To Stop, TVR Soft Stop, Adaptive Control, Brake        | Coast To Stop         |
| 12I | <i>Stop Time-2</i>              | 00:01 to 04:00 (minutes:seconds)                             | 00:03                 |
| 12J | <i>Stop Delay-2</i>             | 00:00 to 01:00 (minutes:seconds)                             | 00:00                 |
| 12K | <i>Adaptive Stop Profile-2</i>  | Early Deceleration, Constant Deceleration, Late Deceleration | Constant Deceleration |
| 12L | <i>Adaptive Control Gain-2</i>  | 1 to 200%  | 75%                   |
| 12M | <i>Brake Torque-2</i>           | 20 to 100%   | 20%                   |
| 12N | <i>Brake Time-2</i>             | 00:01 to 00:30 (minutes:seconds)                             | 00:01                 |

### 8.8.14 Group 13 - Slip Ring Motors

| No  | Function                 | Range                  | Default     |
|-----|--------------------------|------------------------|-------------|
| 13A | <i>Motor Data-1 Ramp</i> | Single Ramp, Dual Ramp | Single Ramp |
| 13B | <i>Motor Data-2 Ramp</i> |                        |             |

Selects whether to use a single or dual current ramp profile for soft starting. Set to single ramp for non-slip ring induction motors, or dual ramp for slip-ring induction motors. Pr **13A** selects the ramp configuration for the primary motor and Pr **13B** selects the ramp configuration for the secondary motor.

| No  | Function                | Range     | Default |
|-----|-------------------------|-----------|---------|
| 13C | <i>Slip Ring Retard</i> | 10 to 90% | 50%     |

Sets the level of conduction after the rotor resistance contactor closes, as a percentage of full conduction. Set so that no current pulse occurs, but the motor retains enough speed to start correctly.

| No  | Function               | Range         | Default |
|-----|------------------------|---------------|---------|
| 13D | <i>Changeover Time</i> | 100 to 500 ms | 150 ms  |

Sets the delay between the rotor resistance relay closing and the low resistance current ramp starting. Set so that the contactor has enough time to close, but the motor does not slow down.

Pr **13D** only applies if Pr **13A** or **13B** is set to 'Dual Ramp', and an output relay is set to 'Changeover Contactor'.

### 8.8.15 Group 14 - RTD/PT100

The Digistart D3 has one RTD/PT100 input and can be fitted with another six PT100 inputs by using the RTD/PT100 and ground fault protection card. The inputs can trip the soft starter when the temperature exceeds a specified point, and different trip temperatures can be set for each input.

PT100 inputs B to G are only available if the RTD/PT100 and ground fault protection card has been installed.

| No  | Function              | Range       | Default |
|-----|-----------------------|-------------|---------|
| 14A | <i>RTD/PT100 A °C</i> | 0 to 250 °C | 50 °C   |
| 14B | <i>RTD/PT100 B °C</i> |             |         |
| 14C | <i>RTD/PT100 C °C</i> |             |         |
| 14D | <i>RTD/PT100 D °C</i> |             |         |
| 14E | <i>RTD/PT100 E °C</i> |             |         |
| 14F | <i>RTD/PT100 F °C</i> |             |         |
| 14G | <i>RTD/PT100 G °C</i> |             |         |

Sets the trip points for the RTD/PT100 inputs.

### 8.8.16 Group 15 - Restricted

| No  | Function           | Range     | Default |
|-----|--------------------|-----------|---------|
| 15A | <i>Access Code</i> | 0 to 9999 | 0000    |

Sets the access code to control access to restricted sections of the menus.

Use the ← and M buttons to select which digit to alter and use the ^ and v buttons to change the value.

**NOTE** In the event of a lost access code, contact your supplier for a master access code that allows you to re-program a new access code.

| No  | Function             | Range           | Default |
|-----|----------------------|-----------------|---------|
| 15B | <i>Emergency Run</i> | Disable, Enable | Disable |

Selects whether the soft starter will permit emergency run operation. In emergency run, the soft starter will start (if not already running) and continue to operate until emergency run ends, ignoring stop commands and trips.

Emergency run is controlled using a programmable input.

To end emergency run operation, open the input.



Continued use of Emergency Run is not recommended. Emergency Run may compromise the starter life as all protections and trips are disabled.

Using the starter in Emergency Run mode will void the product warranty.

| No  | Function               | Range                   | Default      |
|-----|------------------------|-------------------------|--------------|
| 15C | <i>Adjustment Lock</i> | Read & Write, Read Only | Read & Write |

Selects whether the keypad will allow parameters to be changed via the Programming Menu.

| No  | Function                  | Range                              | Default              |
|-----|---------------------------|------------------------------------|----------------------|
| 15D | <i>Shorted SCR Action</i> | 3-Phase Control Only, PowerThrough | 3-Phase Control Only |

Selects whether the soft starter will allow PowerThrough operation, if the soft starter is damaged on one phase. The soft starter will use two-phase control, allowing the motor to continue operating in critical applications.

- PowerThrough can only operate with internally bypassed soft starters.

- PowerThrough is only available with in-line installations. If the starter is installed inside delta, PowerThrough will not operate.
- PowerThrough remains active until '3-Phase Control Only' is reselected.

A shorted SCR or a short within the bypass contactor will trip the starter on 'Lx-Tx shorted'. If PowerThrough is enabled, the trip can be reset and subsequent starts will use PowerThrough two-phase control; however not all features will be available. The trip LED will flash and the display will indicate '2 Phase - Damaged SCR'.



PowerThrough uses a two-phase soft start technology and additional care is required when sizing circuit breakers and protection. Contact your local supplier for assistance.



The starter will trip on Lx-Tx Shorted on the first start attempt after control power is applied. PowerThrough will not operate if control power is cycled between starts.

PowerThrough operation does not support Adaptive Control soft starting or soft stopping. In PowerThrough, the Digistart D3 will automatically select constant current soft starting and timed voltage ramp soft stopping. If PowerThrough is enabled, Pr **2C** and **2B** must be set appropriately.

| No  | Function          | Range      | Default |
|-----|-------------------|------------|---------|
| 15E | <i>Jog Torque</i> | 20 to 100% | 50%     |

Sets the torque level for jog operation. See the section *Jog Operation* for more details.

### 8.8.17 Group 16 - Protection Action

These parameters define how the soft starter will respond to different protection events. The soft starter can trip, issue a warning, or ignore different protection events as required. All protection events are written to the event log. The default action for all protections is to trip the soft starter.

Protections **16P** *Ground Fault* and **16R** to **16W** *RTD/PT100* are only available if the RTD/PT100 and ground fault protection card has been fitted.



Defeating the protection may compromise the starter and motor, and should only be done in the case of emergency.

| No  | Function                        | Range                                | Default      |
|-----|---------------------------------|--------------------------------------|--------------|
| 16A | <i>Motor Overload</i>           | Trip Starter, Warn and Log, Log Only | Trip Starter |
| 16B | <i>Excess Start Time</i>        |                                      |              |
| 16C | <i>Current Imbalance</i>        |                                      |              |
| 16D | <i>Underpower</i>               |                                      |              |
| 16E | <i>Overpower</i>                |                                      |              |
| 16F | <i>Reserved</i>                 |                                      |              |
| 16G | <i>Reserved</i>                 |                                      |              |
| 16H | <i>Frequency</i>                |                                      |              |
| 16I | <i>Input A Trip</i>             |                                      |              |
| 16J | <i>Input B Trip</i>             |                                      |              |
| 16K | <i>Motor Thermistor</i>         |                                      |              |
| 16L | <i>Starter Communication</i>    |                                      |              |
| 16M | <i>Network Communication</i>    |                                      |              |
| 16N | <i>Heatsink Overtemperature</i> |                                      |              |
| 16O | <i>Battery/Clock</i>            |                                      |              |
| 16P | <i>Ground Fault</i>             |                                      |              |
| 16Q | <i>RTD/PT100 A</i>              |                                      |              |
| 16R | <i>RTD/PT100 B</i>              |                                      |              |
| 16S | <i>RTD/PT100 C</i>              |                                      |              |
| 16T | <i>RTD/PT100 D</i>              |                                      |              |
| 16U | <i>RTD/PT100 E</i>              |                                      |              |
| 16V | <i>RTD/PT100 F</i>              |                                      |              |
| 16W | <i>RTD/PT100 G</i>              |                                      |              |
| 16X | <i>Low Control Volts</i>        |                                      |              |

Selects the soft starter's response to each protection.

## 8.9 Maintenance tools

### 8.9.1 Setup tools

**NOTE** These functions are protected by the access code (see *Access code* on page 45).

#### Load/save settings

The Load/Save Settings menu requires an access code and allows users to:

- Load the Digistart D3's parameters with default values
- Reload previously saved parameter settings from an internal file
- Save the current parameter settings to an internal file

In addition to the factory default values file, the Digistart D3 can store two user-defined parameter files. These files contain default values until a user file is saved.

The available options are:

**Table 8-7 Load/Save settings options**

|                 |  |
|-----------------|--|
| Load Defaults   | Restores the starter to the factory default settings for all parameters except Pr <b>9A Language</b> . This does not reset the access code.                            |
| Load Backup     | Synchronises parameters between the starter and the keypad. See <i>Synchronising the keypad and the starter</i> on page 34 for details of the synchronisation process. |
| Save User Set 1 | Saves the current parameter settings to a file. This file contains default parameter settings until a user file is saved.  |
| Load User Set 1 | Reloads the parameter settings from User Set 1.  |
| Save User Set 2 | Saves the current parameter settings to a file. This file contains default parameter settings until a user file is saved.  |
| Load User Set 2 | Reloads the parameter settings from User Set 2.  |

**NOTE** The saved files and current operating settings are stored in both the keypad and in the soft starter. The keypad will prompt you to synchronise the settings whenever it is plugged into a new Digistart D3.

To load or save parameter settings, see *Load defaults* on page 46.

#### Set date and time

To set the date and time:

1. Open the Programming Menu and select Setup Tools. Enter the access code.
2. Scroll to the date/time screen.
3. Press the **M** button to enter edit mode.
4. Press the **M** and  $\leftarrow$  buttons to select which part of the date or time to edit.
5. Use the  $\wedge$  and  $\vee$  buttons to change the value.
6. To save changes, press the **M** button. The Digistart D3 will confirm the changes. To cancel changes, press the  $\leftarrow$  button.

#### Reset thermal models

The Digistart D3's advanced thermal modelling software constantly monitors the motor's performance. This allows the Digistart D3 to calculate the motor's temperature and ability to start successfully at any time. If the Digistart D3 is configured for use on two motors, each motor's temperature is modelled separately.

The thermal model for the active motor can be reset if required.

1. Open the Programming Menu and select Setup Tools. Enter the access code.
2. Scroll to Reset Thermal Models and press **M**.

|   |
|---|
| Reset Thermal Models<br>M1 X%<br>M2 X%<br><b>M to Reset</b> |
|---|

3. Use  $\vee$  to select Reset and press **M** to confirm.

|                       |
|-----------------------|
| Do Not Reset<br>Reset |
|-----------------------|

4. When the thermal model has been reset, the screen will display a confirmation message then return to the previous screen.

**NOTE** This action will reset both thermal models.

**NOTE** The second thermal model is only active if Pr **11B Dual Thermal Model** is set to 'Dual' and the starter is using the secondary motor set (a programmable input is set to 'Motor Set Select' and the input is active).



Resetting the motor thermal model may compromise motor life and should only be done in the case of emergency.

## 8.9.2 Simulations

Software simulation functions let you test the soft starter's operation and control circuits without connecting the soft starter to mains voltage. The simulations are accessed via the Simulations menu.

The Digistart D3 has three simulation functions:

- The **protection simulation** simulates activation of each protection mechanism to confirm that the soft starter and associated control circuits are responding correctly. See *Protection simulation* for details.
- The **run simulation** simulates a motor starting, running and stopping to confirm that the soft starter and associated equipment have been installed correctly. The run simulation follows the protection simulations in the Simulations menu. See *Run simulation* on page 68 for details.
- The **output signal simulation** simulates output signalling to confirm that outputs and associated control circuits are operating correctly. The output signal simulation follows the run simulation in the Simulations menu. See *Output signal simulations* on page 69 for details.

The simulations are only available when the soft starter is in Ready state, control voltage is available and the keypad is active.

Access to the simulation tools is protected by the access code (see *Access code* on page 45).

**NOTE** The default access code is 0000.

### Protection simulation

To use the protection simulation:

1. Open the Programming Menu and select Simulations.
2. Use the  $\wedge$  and  $\vee$  buttons to select the protection you want to simulate.
3. Press and hold **M** to simulate the selected protection.
4. The screen is displayed momentarily. The soft starter's response depends on the Protection Action setting (parameter group 16).
5. Use  $\wedge$  or  $\vee$  to select another simulation, or press  $\leftarrow$  to exit.

|  |
|--|
| 0.0A<br>Tripped<br>Selected Protection |
|--|

### Run simulation

You can end the simulation at any time by pressing  $\leftarrow$ .

To use the run simulation:

1. Open the Programming Menu and select Simulations.
2. Scroll to Run Simulation and press **M**.
3. Press **START** or activate the start input. The Digistart D3 simulates its pre-start checks and closes the main contactor relay. The Run LED flashes.
4. Press **M**. The Digistart D3 simulates starting. The Run LED flashes.
5. Press **M**. The Digistart D3 simulates running. The Run LED stays on without flashing and the bypass contactor relay closes.

|   |
|---|
| Run Simulation<br>Ready<br>Apply Start Signal |
|---|

|  |
|--|
| Run Simulation<br>Pre-Start Checks<br><b>M</b> to Continue |
|--|

|  |
|--|
| Run Simulation<br>ATTENTION!<br>Remove Mains Volts<br><b>M</b> to Continue |
|--|

|   |
|---|
| Run Simulation<br>Starting XXXs<br><b>M</b> to Continue |
|---|

|  |
|--|
| Run Simulation<br>Running<br>Apply Stop Signal |
|--|

6. Press **STOP** or activate the stop input. The Digistart D3 simulates stopping. The Run LED flashes and the bypass contactor relay opens.

|   |
|---|
| Run Simulation<br>Stopping X:XXs<br>M to Continue |
|---|

7. Press **M**. The Ready LED flashes and the main contactor relay opens.

|  |
|--|
| Run Simulation<br>Stopped<br>M to Continue |
|--|

8. Press **M** to return to the commissioning menu.

### Testing the installation

The Digistart D3 can be connected to a small motor for testing. During this test, the soft starter's control input and relay output protection settings can be tested. This test mode is not suitable for testing soft starting or soft stopping performance.

The FLC of the test motor must be at least 2% of the soft starter's minimum FLC (see *Minimum and maximum current settings* on page 11).

**NOTE** When testing the soft starter with a small motor, set Pr **1A Motor Full Load Current** to the minimum allowable value.

### Output signal simulations

The following outputs are available to simulate:

- Programmable relay A
- Programmable relay B
- Programmable relay C
- Run relay
- Low current flag
- High current flag
- Motor temperature flag
- Analog output A
- Analog output B

**NOTE** To test operation of the flags (motor temperature and low/high current), set an output relay to the appropriate function and monitor the relay's behaviour.

To use the signal simulation:

1. Open the Menu and select Simulation.
2. Use the  $\wedge$  and  $\vee$  buttons to select a function to simulate, then press **M**.
3. Use the  $\wedge$  and  $\vee$  buttons to turn the signal on and off. To confirm correct operation, monitor the state of the output.

|                           |
|---------------------------|
| Prog Relay A<br>Off<br>On |
|---------------------------|

4. Press  $\leftarrow$  to return to the simulation list.

The analog output simulation uses the  $\wedge$  and  $\vee$  buttons to change the current at the analog output terminals.

|                                |
|--------------------------------|
| Analog Output A<br>0%<br>4.0mA |
|--------------------------------|

Attach a current measuring device to the analog output terminals. Use the  $\wedge$  or  $\vee$  button to adjust the percentage value on the display. The current measuring device should indicate the same level of current as shown on the display.

If the input/output expansion card is fitted, the simulation can also be used to test the operation of Relays D, E, F and Analog Output B.

### 8.9.3 I/O state

#### Analog I/O state

This screen shows the current status of the Analog I/O

|  |
|--|
| Analog I/O State<br>Input: --- %<br>Output A: 04.0mA |
|--|

This screen will also show Analog Output B if the expansion card is fitted.

#### Digital I/O state

This screen shows the current status of the digital inputs and outputs.

|  |
|--|
| Digital I/O State<br>Inputs: 0110000<br>Outputs: 0000100 |
|--|

|                    |             |                         |                         |                   |                           |           |                    |             |                      |                |             |         |
|--------------------|-------------|-------------------------|-------------------------|-------------------|---------------------------|-----------|--------------------|-------------|----------------------|----------------|-------------|---------|
| Safety Information | Rating Data | Mechanical Installation | Electrical Installation | Keypad and Status | Quick Start Commissioning | Operation | <b>Programming</b> | Diagnostics | Application Examples | Technical Data | Maintenance | Options |
|--------------------|-------------|-------------------------|-------------------------|-------------------|---------------------------|-----------|--------------------|-------------|----------------------|----------------|-------------|---------|

The top line of the screen shows the start, stop, reset and programmable inputs (A and B, then inputs on the I/O expansion card (if fitted)).

The bottom line of the screen shows programmable output A, the fixed Run output, programmable outputs B and C, then the outputs on the expansion card (if fitted).

### Temperature sensors state

This screen shows the state of the motor thermistors and RTD/PT100s.

S = Short

H = Hot

C = Cold

O = Open

|   |
|---|
| Temp Sensors State<br>Thermistor: 0<br>RTD/PT100s:0000000<br>S = Shrt H=Hot C=Cld O=Opn |
|---|

RTD/PT100s B to G are only available if the RTD/PT100 and Ground Fault expansion card is fitted.

### 8.9.4 Logs menu

The Logs Menu provides information on events, trips and starter performance.

To open the Logs Menu, press the **M** button, then scroll to Logs and press **M** again.

#### Trip log

The Trip Log stores details of the eight most recent trips, including the date and time the trip happened. Trip 1 is the most recent and trip 8 is the oldest stored trip.

To open the Trip Log:

1. Open the Logs Menu.
2. Scroll to Trip Log and press **M**.
3. Use the  $\wedge$  and  $\vee$  buttons to select a trip to view, and press **M** to display details.

To close the log and return to the main display, press  $\leftarrow$  repeatedly.

#### Event log

The Event Log stores time-stamped details of the starter's 99 most recent events (actions, warnings and trips), including the date and time of the event. Event 1 is the most recent and event 99 is the oldest stored event.

To open the Event Log:

1. Open the Logs Menu.
2. Scroll to Event Log and press **M**.
3. Use the  $\wedge$  and  $\vee$  buttons to select an event to view, and press **M** to display details.

To close the log and return to the main display, press  $\leftarrow$  repeatedly.

### 8.9.5 Performance counters

The performance counters store statistics on the starter's operation:

- Hours run (lifetime and since counter last reset)
- Number of starts (lifetime and since counter last reset)
- Motor kWh (lifetime and since counter last reset)
- Number of times the thermal model has been reset

The resettable counters (hours run, starts and motor kWh) can only be reset if the *Adjustment Lock* (Pr **15C**) is set to Read & Write.

To view the counters:

1. Open the Programming Menu and select Counters.
2. Use the  $\wedge$  and  $\vee$  buttons to scroll through the counters. Press **M** to view details.
3. To reset a counter, press **M** then press **M** to confirm the action.

To return to the previous level, press  $\leftarrow$ .

**NOTE** The reset counters function is protected by the access code.

## 9. Diagnostics

**NOTE** The Digistart D3 soft starter is not user serviceable. The unit should only be serviced by authorised service personnel. Unauthorised tampering with the unit will void the product warranty.

### 9.1 Protection responses

When a protection condition is detected, the Digistart D3 will write this to the event log and may also trip or issue a warning. The soft starter's response depends on the Protection Action setting (parameter group 16).

Some protection responses cannot be adjusted by the user. These trips are usually caused by external events (such as phase loss) or by a fault within the soft starter. These trips do not have associated parameters and cannot be set to Warn or Log.

If the Digistart D3 trips you will need to identify and clear the condition that triggered the trip, then reset the soft starter before restarting. To reset the starter, press the **RESET** button on the keypad or activate the Reset remote input.

If the Digistart D3 has issued a warning, the soft starter will reset itself once the cause of the warning has been resolved.

### 9.2 Trip messages

This table lists soft starter's protection mechanisms and the probable cause of the trip. Some of these can be adjusted using parameter group 5 *Protection Settings* and parameter group 16 *Protection Action*, other settings are built-in system protections and cannot be set or adjusted.

**Table 9-1 Trip messages**

| Display               | Possible cause/Suggested solution   |
|-----------------------|---|
| 2 Phase - Damaged SCR | This message is displayed if the soft starter tripped on "Lx-Tx shorted" during the pre-start checks and PowerThrough is enabled. It indicates that the starter now operates in PowerThrough mode (2-phase control only).<br>Check for either a shorted SCR or a short within the bypass contactor.<br>Related Pr: <b>15D</b>   |
| Analog input trip     | This fault only occurs if the Input/Output expansion card is fitted. Identify and resolve the condition which caused Analog Input A to activate.<br>Related Pr: <b>8A, 8B, 8C</b>   |
| Battery/clock         | A verification error has occurred on the real time clock, or the backup battery voltage is low. If the battery is low and the power is off, date/time settings will be lost. Reprogram the date and time.<br>Related Pr: <b>16O</b>   |
| Current imbalance     | Current imbalance can be caused by problems with the motor, the environment or the installation, such as: <ul style="list-style-type: none"> <li>• An imbalance in the incoming mains voltage</li> <li>• A problem with the motor windings</li> <li>• A light load on the motor</li> <li>• A phase loss on input terminals L1, L2 or L3 during Run mode</li> </ul> An SCR that has failed open circuit. A failed SCR can only be definitely diagnosed by replacing the SCR and checking the starter's performance.<br>Related Pr: <b>5C, 6A, 16C</b><br>Please contact LEROY-SOMER or your local distributor.   |
| Current Read Err Lx   | Where 'X' is 1, 2 or 3.<br>Internal fault (PCB fault). The output from the CT circuit is not close enough to zero when the SCRs are turned off. Contact your local supplier for advice.<br>This trip is not adjustable.<br>Related Pr: None   |
| Excess start time     | Excess start time trip can occur in the following conditions: <ul style="list-style-type: none"> <li>• Pr <b>1A Motor Full Load Current</b> is not appropriate for the motor</li> <li>• Pr <b>2B Current Limit</b> has been set too low</li> <li>• Pr <b>2D Start Ramp Time</b> has been set greater than the setting for <b>5A Excess Start Time</b> setting</li> <li>• Pr <b>2D Start Ramp Time</b> is set too short for a high inertia load when using Adaptive Control</li> </ul> Related Pr: <b>1A, 2B, 2D, 5A, 5B, 11A, 12B, 12D, 16B</b>   |
| Firing Fail Px        | Where 'X' is phase 1, 2 or 3.<br>The SCR did not fire as expected. The SCR may be faulty or there may be an internal wiring fault.<br>This trip is not adjustable.<br>Related Pr: None  |
| FLC too high          | This trip is not adjustable.<br>The Digistart D3 can support higher motor full load current values when connected to the motor using inside delta configuration rather than in-line connection. If the soft starter is connected in-line but the programmed setting for Pr <b>1A Motor Full Load Current</b> is above the in-line maximum, the soft starter will trip at start (see <i>Minimum and maximum current settings</i> on page 11).<br>If the soft starter is connected to the motor using inside delta configuration, the soft starter may not be correctly detecting the connection. Contact your local supplier for advice.<br>Related Pr: <b>1A, 11A</b> |

| Display   | Possible cause/Suggested solution   |
|---|---|
| Frequency                                       | The mains frequency has gone beyond the specified range.<br>Check for other equipment in the area that could be affecting the mains supply, particularly variable speed drives and switch mode power supplies (SMPS).<br>If the Digistart D3 is connected to a generator set supply, the generator may be too small or could have a speed regulation problem.<br>This trip is not adjustable.<br>Related Pr: <b>5I, 5J, 6F, 16H</b>   |
| Ground fault                                    | This fault only occurs if the RTD/Ground Fault card is fitted. Test the insulation of the output cables and the motor. Identify and resolve the cause of any ground fault.<br>Related Pr: <b>5K, 6H, 16P</b>  |
| Heatsink overtemperature                        | Check if cooling fans are operating. If mounted in an enclosure, check if ventilation is adequate. Fans operate during Start, Run and for 10 minutes after the starter exits the Stop state.<br><br><b>NOTE</b> Models D3-1x-0023-B to D3-1x-0053-B and D3-1x-0170-B do not have a cooling fan. Models with fans will operate the cooling fans from a Start until 10 minutes after a Stop.<br>Related Pr: <b>16N</b>  |
| High Level                                      | This is a name selected for a programmable input. See Input trip.   |
| High Pressure                                   | This is a name selected for a programmable input. See Input trip.   |
| Input trip                                      | One of the soft starter's inputs is set to a trip function and has activated. Check the status of the inputs to identify which input has activated, then resolve the trigger condition.<br>Related Pr: <b>3A, 3B, 3C, 3D, 3E, 3F, 3G, 3H, 3I, 3J, 16I, 16J</b>  |
| Instantaneous overcurrent                       | Current to the motor has exceeded the soft starter's built-in trip points: <ul style="list-style-type: none"> <li>• 7.2 times the Pr <b>1A Motor Full Load Current</b></li> <li>• 6 times the starter's nominal current rating</li> </ul> Causes can include a locked rotor condition or an electrical fault in the motor or cabling.<br>This trip is not adjustable.<br>Related Pr: None   |
| Internal fault X                                | This trip is not adjustable.<br>The Digistart D3 has tripped on an internal fault. Contact your local supplier with the fault code (X).<br>Related Pr: None   |
| L1 phase loss<br>L2 phase loss<br>L3 phase loss | This trip is not adjustable.<br>During pre-start checks the starter has detected a phase loss as indicated.<br>In run state, the starter has detected that the current on the affected phase has dropped below 3.3% of the programmed motor FLC for more than 1 second, indicating that either the incoming phase or connection to the motor has been lost.<br>Check the supply and the input and output connections at the starter and at the motor end.<br>Phase loss can also be caused by a failed SCR, particularly an SCR that has failed open circuit. A failed SCR can only be definitely diagnosed by replacing the SCR and checking the starter's performance.<br>Related Pr: None<br>Please contact LEROY-SOMER or your local distributor. |
| L1-T1 shorted<br>L2-T2 shorted<br>L3-T3 shorted | During pre-start checks the starter has detected a shorted SCR or a short within the bypass contactor as indicated. If the starter is connected in-line with the motor, consider using PowerThrough to allow operation until the starter can be repaired.<br><br><b>NOTE</b> PowerThrough is only available with in-line installations. If the starter is installed inside delta, PowerThrough will not operate.<br><br>The starter will trip on Lx-Tx Shorted on the first start attempt after control power is applied. PowerThrough will not operate if control power is cycled between starts.<br>Related Pr: <b>15D</b>  |
| Low Control Volts                               | The Digistart D3 has detected a drop in the control voltage. <ul style="list-style-type: none"> <li>• Check the external control supply (terminals CSH, CSL, CSR) and reset the starter.</li> </ul> If the external control supply is stable: <ul style="list-style-type: none"> <li>• the 24 V supply on the main control PCB may be faulty; or</li> <li>• the bypass driver PCB may be faulty (internally bypassed models only). Contact your local supplier for advice.</li> </ul> This protection is not active in Ready state.<br>Related Pr: <b>16X</b>   |
| Low Level                                       | This is a name selected for a programmable input. See Input trip.   |
| Low Pressure                                    | This is a name selected for a programmable input. See Input trip.   |

| Display  | Possible cause/Suggested solution  |
|--|--|
| Motor overload                                     | The motor has reached its maximum thermal capacity. Overload can be caused by: <ul style="list-style-type: none"> <li>The soft starter protection settings not matching the motor thermal capacity</li> <li>Excessive starts per hour</li> <li>Excessive throughput</li> <li>Damage to the motor windings</li> </ul> Resolve the cause of the overload and allow the motor to cool.<br>Related Pr: <b>1A, 1B, 1C, 1D, 16A</b>  |
| Motor 2 overload                                   | See 'Motor overload' above.<br><br><b>NOTE</b> Applicable only if the second motor set has been programmed.<br>Related Pr: <b>11A, 11B, 11C, 11D, 11E, 16A</b>   |
| Motor Connection Tx                                | Where 'X' is 1, 2 or 3.<br>The motor is not connected correctly to the soft starter for in-line or inside delta use. <ul style="list-style-type: none"> <li>Check individual motor connections to the soft starter for power circuit continuity.</li> <li>Check connections at the motor terminal box.</li> </ul> This trip is not adjustable.<br>Related Pr: None   |
| Motor thermistor                                   | The motor thermistor input has been enabled and: <ul style="list-style-type: none"> <li>The resistance at the thermistor input has exceeded 3.6 kΩ for more than one second.</li> <li>The motor winding has overheated. Identify the cause of the overheating and allow the motor to cool before restarting.</li> <li>The motor thermistor input has been opened.</li> </ul> <b>NOTE</b> If a valid motor thermistor is no longer used, a 1.2 kΩ resistor must be fitted across terminals TH1, TH2.<br>Related Pr: <b>16K</b>  |
| Network communication (between module and network) | The network master has sent a trip command to the starter, or there may be a network communication problem.<br>Check the network for causes of communication inactivity.<br>Related Pr: <b>16M</b>   |
| No Flow  | This is a name selected for a programmable input. See Input trip.  |
| Overpower  | <ul style="list-style-type: none"> <li>The motor has experienced a sharp rise in power. Causes can include a momentary overload condition which has exceeded the adjustable delay time.</li> </ul> Related Pr: <b>5F, 6C, 16E</b>  |
| Parameter out of Range                             | This trip is not adjustable. <ul style="list-style-type: none"> <li>A parameter value is outside the valid range.</li> </ul> The keypad will indicate the first invalid parameter. <ul style="list-style-type: none"> <li>An error occurred loading data from the EEPROM to RAM when the keypad powered up.</li> <li>The parameter set or values in the keypad do not match the parameters in the starter.</li> <li>"Load User Set" has been selected but no saved file is available.</li> </ul> Reset the fault. The starter will load the default settings. If the problem persists, contact your local distributor.<br>Related Pr: None |
| Phase sequence                                     | The phase sequence on the soft starter's input terminals (L1, L2, L3) is not valid.<br>Check the phase sequence on L1, L2, L3 and ensure the setting in Pr <b>5D</b> is suitable for the installation.<br>Related Pr: <b>5D</b>  |
| FLC  | This is a name selected for a programmable input. See Input trip.  |
| Power loss   | This trip is not adjustable.<br>The starter is not receiving mains supply on one or more phases when a Start Command is given. Check that the main contactor closes when a start command is given, and remains closed until the end of a soft stop. Check the fuses. If testing the soft starter with a small motor, it must draw at least 2% of its minimum FLC setting on each phase.<br>Related Pr: None  |
| Pump Fault   | This is a name selected for a programmable input. See Input trip.  |
| RTD/PT100 A<br>RTD/PT100 B to G                    | The RTD/PT100 set temperature has been exceeded and tripped the soft starter. Identify and resolve the condition which caused the appropriate input to activate.<br><br><b>NOTE</b> PT100 B to PT100 G are applicable only if a RTD/PT100 and Ground Fault card is fitted.<br>Related Pr: <b>14A, 14B, 14C, 14D, 14E, 14F, 14G, 16Q to 16W</b>   |
| RTD/PT100 X Circ                                   | Indicates that the indicated RTD/PT100 has short circuited. Check and resolve this condition.<br>Related Pr: None.   |

| Display   | Possible cause/Suggested solution  |
|---|--|
| Starter communication (between module and soft starter)     | <ul style="list-style-type: none"> <li>There is a problem with the connection between the soft starter and the optional communications module. Remove and reinstall the module. If the problem persists, contact your local distributor.</li> <li>There is an internal communications error within the soft starter. Contact your local distributor.</li> </ul> Related Pr: <b>16L</b> |
| Starter Disable   | This is a name selected for a programmable input. See Input trip.  |
| Thermistor Cct (Thermistor circuit)                         | The thermistor input has been enabled and: <ul style="list-style-type: none"> <li>The resistance at the input has fallen below 20 Ω (the cold resistance of most thermistors will be over this value) or</li> <li>A short circuit has occurred. Check and resolve this condition.</li> </ul> Related Pr: None  |
| Time-overcurrent  | The Digistart D3 is internally bypassed and has drawn high current during running. (The 10A protection curve trip has been reached or the motor current has risen to 600% of the motor FLC setting.)<br>Related Pr: None   |
| Underpower  | The motor has experienced a sharp drop in power, caused by loss of load. Causes can include broken components (shafts, belts or couplings), or a pump running dry.<br>Related Pr: <b>5E, 6B, 16D</b>   |
| Unsupported option (function not available in inside delta) | This trip is not adjustable.<br>The selected function is not available (eg jog is not supported in inside delta configuration).<br>Related Pr: None  |
| Vibration   | This is a name selected for a programmable input. See Input trip.  |
| VZC Fail P <sub>X</sub>                                     | Where 'X' is 1, 2 or 3.<br>Internal fault (PCB fault). Contact your local supplier for advice.<br>This trip is not adjustable.<br>Related Pr: None   |

### 9.3 General faults

This table describes situations where the soft starter does not operate as expected but does not trip or give a warning.

**Table 9-2 General faults**

| Symptom  | Probable Cause  |
|--|---|
| Starter "Not Ready"  | <ul style="list-style-type: none"> <li>Check Input A (DI4, +24V). The starter may be disabled via a programmable input. If Pr <b>3A</b> or <b>3F</b> is set to Starter Disable and there is an open circuit on the corresponding input, the Digistart D3 will not start.</li> </ul>   |
| The soft starter does not respond to the <b>START</b> or <b>RESET</b> button on the keypad.          | <ul style="list-style-type: none"> <li>The soft starter may be in Remote control mode. When the soft starter is in Remote control mode, the Local LED on the starter is off. Press the <b>LCL/RMT</b> button once to change to Local control.</li> </ul>  |
| The soft starter does not respond to commands from the control inputs.                               | <ul style="list-style-type: none"> <li>The soft starter may be in Local control mode. When the soft starter is in Local control mode, the Local LED on the starter is on. Press the <b>LCL/RMT</b> button once to change to Remote control.</li> <li>The control wiring may be incorrect. Check that the remote start, stop and reset inputs are configured correctly (see <i>Start/stop control logic</i> on page 20 for details).</li> <li>The signals to the remote inputs may be incorrect. Test the signalling by activating each input signal in turn. The appropriate remote control input LED should activate on the starter.</li> </ul>  |
| The soft starter does not respond to a start command from either the local or remote controls.       | <ul style="list-style-type: none"> <li>The soft starter may be waiting for the restart delay to elapse. The length of the restart delay is controlled by Pr <b>6G Restart Delay</b>.</li> <li>The motor may be too hot to permit a start. If Pr <b>5L Motor Temperature Check</b> is set to Check, the soft starter will only permit a start when it calculates that the motor has sufficient thermal capacity to complete the start successfully. Wait for the motor to cool before attempting another start.</li> <li>The starter may be disabled via a programmable input. If Pr <b>3A</b> or <b>3F</b> is set to Starter Disable and there is an open circuit on the corresponding input, the Digistart D3 will not start. If there is no further need to disable the starter, close the circuit on the input.</li> </ul> <div style="text-align: center;">  <p><b>Pr 3M Local/Remote controls</b> when the <b>LCL/RMT</b> button is enabled.</p> </div> |
| A reset does not occur after an Auto-Reset, when using a remote two-wire control.                    | <ul style="list-style-type: none"> <li>The remote 2-wire start signal must be removed and reapplied for a re-start.</li> </ul>  |
| Remote start/stop command is overriding Auto Start/Stop settings when using remote two-wire control. | <ul style="list-style-type: none"> <li>Auto Start/Stop should only be used in remote mode with three-wire or four-wire control.</li> </ul>  |

| Symptom  | Probable Cause  |
|--|---|
| Non-resettable Thermistor Cct trip, when there is a link between the thermistor input TH1, TH2 or when the motor thermistor connected between TH1, TH2 is permanently removed. | <ul style="list-style-type: none"> <li>The thermistor input is enabled once a link is fitted and short circuit protection has activated. <ul style="list-style-type: none"> <li>Remove the link then load the default parameter set. This will disable the thermistor input and clear the trip.</li> <li>Place a 1k2 Ω resistor across the thermistor input.</li> <li>Turn thermistor protection to 'Log only' (Pr <b>16K</b>).</li> </ul> </li> </ul>  |
| The soft starter does not control the motor correctly during starting.   | <ul style="list-style-type: none"> <li>Start performance may be unstable when using a low Motor Full Load Current setting (Pr <b>1A</b>). This can affect use on a small test motor with full load current between 5 A and 50 A.</li> <li>Power factor correction (PFC) capacitors must be installed on the supply side of the soft starter. To control a dedicated PFC capacitor contactor, connect the contactor to run relay terminals.</li> </ul>   |
| Motor does not reach full speed.   | <ul style="list-style-type: none"> <li>If the start current is too low, the motor will not produce enough torque to accelerate to full speed. The soft starter may trip on excess start time.</li> </ul> <p><b>NOTE</b> Make sure the motor starting parameters are appropriate for the application and that you are using the intended motor starting profile. If Pr <b>3A</b> or <b>3F</b> is set to Motor Set Select, check that the corresponding input is in the expected state.</p> <ul style="list-style-type: none"> <li>The load may be jammed. Check the load for severe overloading or a locked rotor situation.</li> </ul>  |
| Erratic motor operation.   | <ul style="list-style-type: none"> <li>The SCRs in the Digistart D3 require at least 5 A of current to latch. If you are testing the soft starter on a motor with full load current less than 5 A, the SCRs may not latch correctly.</li> </ul>   |
| Erratic and noisy motor operation.   | <ul style="list-style-type: none"> <li>If the soft starter is connected to the motor using inside delta configuration, the soft starter may not be correctly detecting the connection. Contact your local supplier for advice.</li> </ul>   |
| Soft stop ends too quickly.  | <ul style="list-style-type: none"> <li>The soft stop settings may not be appropriate for the motor and load. Review the settings of Pr <b>2H</b>, <b>2I</b>, <b>12H</b> and <b>12I</b>.</li> <li>If the motor is very lightly loaded, soft stop will have limited effect.</li> </ul>  |
| Adaptive Control, brake, jog and PowerThrough functions not working.   | <ul style="list-style-type: none"> <li>These features are only available with in-line installation. If the Digistart D3 is installed inside delta, these features will not operate.</li> </ul>  |
| After selecting Adaptive Control the motor used an ordinary start and/or the second start was different to the first.  | <ul style="list-style-type: none"> <li>The first Adaptive Control start is actually 'Constant Current' so that the starter can learn from the motor characteristics. Subsequent starts use Adaptive Control.</li> </ul>   |
| PowerThrough does not operate when selected.   | <ul style="list-style-type: none"> <li>The starter will trip on Lx-Tx Shorted on the first start attempt after control power is applied. PowerThrough will not operate if control power is cycled between starts.</li> </ul>  |
| Starter "awaiting data"  | <ul style="list-style-type: none"> <li>The keypad is not receiving data from the control PCB. Check the cable connection and the fitting of the display on the starter.</li> </ul>  |
| Corrupted text shown on keypad display.  | <ul style="list-style-type: none"> <li>The keypad may not be screwed down, resulting in an intermittent connection. Screw down the keypad or hold squarely in place.</li> </ul>   |
| Display is distorted   | <ul style="list-style-type: none"> <li>Check that the keypad has not been screwed down too tightly. Loosen screws slightly.</li> </ul>  |
| Parameter settings cannot be stored.   | <ul style="list-style-type: none"> <li>Make sure you are saving the new value by pressing the <b>M</b> button after adjusting a parameter setting. If you press <b>←</b>, the change will not be saved.</li> <li>Check that the adjustment lock (Pr <b>15C</b>) is set to <i>Read &amp; Write</i>. If the adjustment lock is set to <i>Read Only</i>, settings can be viewed but not changed. You need to know the security access code to change the adjustment lock setting.</li> <li>The EEPROM may be faulty on the keypad. A faulty EEPROM will also trip the soft starter, and the keypad will display the message Parameter out of Range. Contact your local supplier for advice.</li> </ul> |
| ATTENTION! Remove Mains Volts  | <ul style="list-style-type: none"> <li>The soft starter will not activate Run Simulation with three-phase power connected. This prevents unintentional direct on-line (DOL) start.</li> </ul>   |
| Line fuses blown.  | <ul style="list-style-type: none"> <li>Check the fuse rating and ensure that the selected starting method matches with the application.</li> </ul>  |

# 10. Application Examples

A selection of Application Notes are available describing advanced installation or configuration of the Digistart D3 for situations with specific performance requirements. Application notes are available for situations including brake and jog operation, pumping and advanced protection options.

## 10.1 Installation with main contactor

The Digistart D3 is installed with a main contactor (AC3 rated). Control voltage must be supplied from the input side of the contactor. The main contactor is controlled by the Digistart D3 Main Contactor output, which by default is assigned to Output Relay A (terminals COM1, RLO1).

Figure 10-1 Installation with main contactor

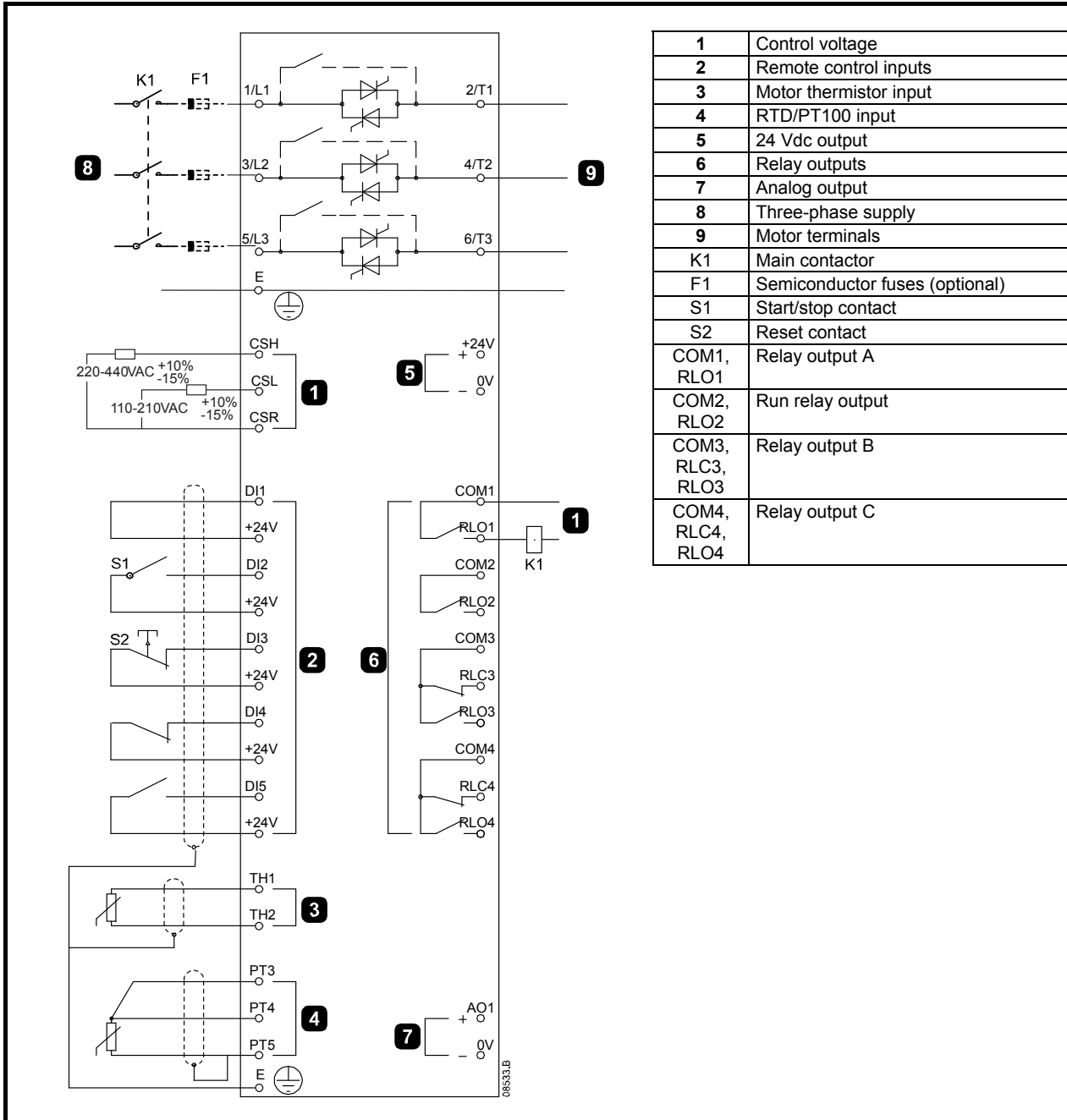

Parameter settings:

- Pr 4A Relay A Action
  - Select 'Main Contactor' - assigns the Main Contactor function to Relay Output A (default setting)

## 10.2 Installation with external bypass contactor

The Digistart D3 is installed with an external bypass contactor (AC1 rated). The bypass contactor is controlled by the Digistart D3 Run Output (terminals COM2, RLO2).

Figure 10-2 Installation with bypass contactor

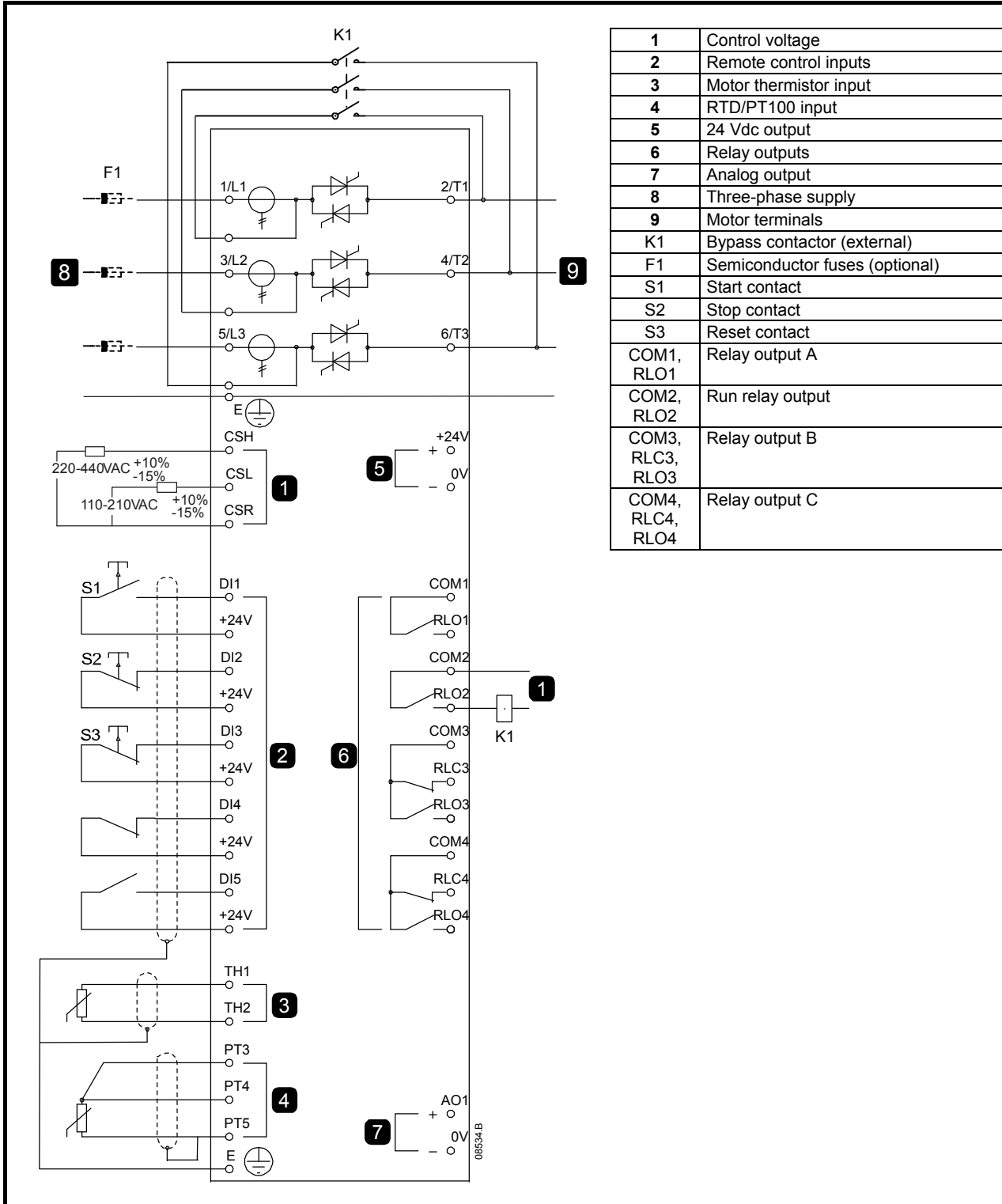

Parameter settings:

- No special settings required.

### 10.3 Emergency run operation

In normal operation the Digistart D3 is controlled via a remote two wire signal (terminals DI2, +24V).

Emergency Run is controlled by a two wire circuit connected to Input A (terminals DI4, +24V). Closing Input A causes the Digistart D3 to run the motor and ignore certain trip conditions.

**NOTE** Although the Emergency Run satisfies the functionality requirements of Fire Mode, LEROY-SOMER does not recommend its use in situations that require testing and/or compliance with specific standards as it is not certified.



Continued use of Emergency Run is not recommended. Emergency Run may compromise the starter life as all protections and trips are disabled.

Using the starter in Emergency Run mode will void the product warranty.

Figure 10-3 Emergency run operation

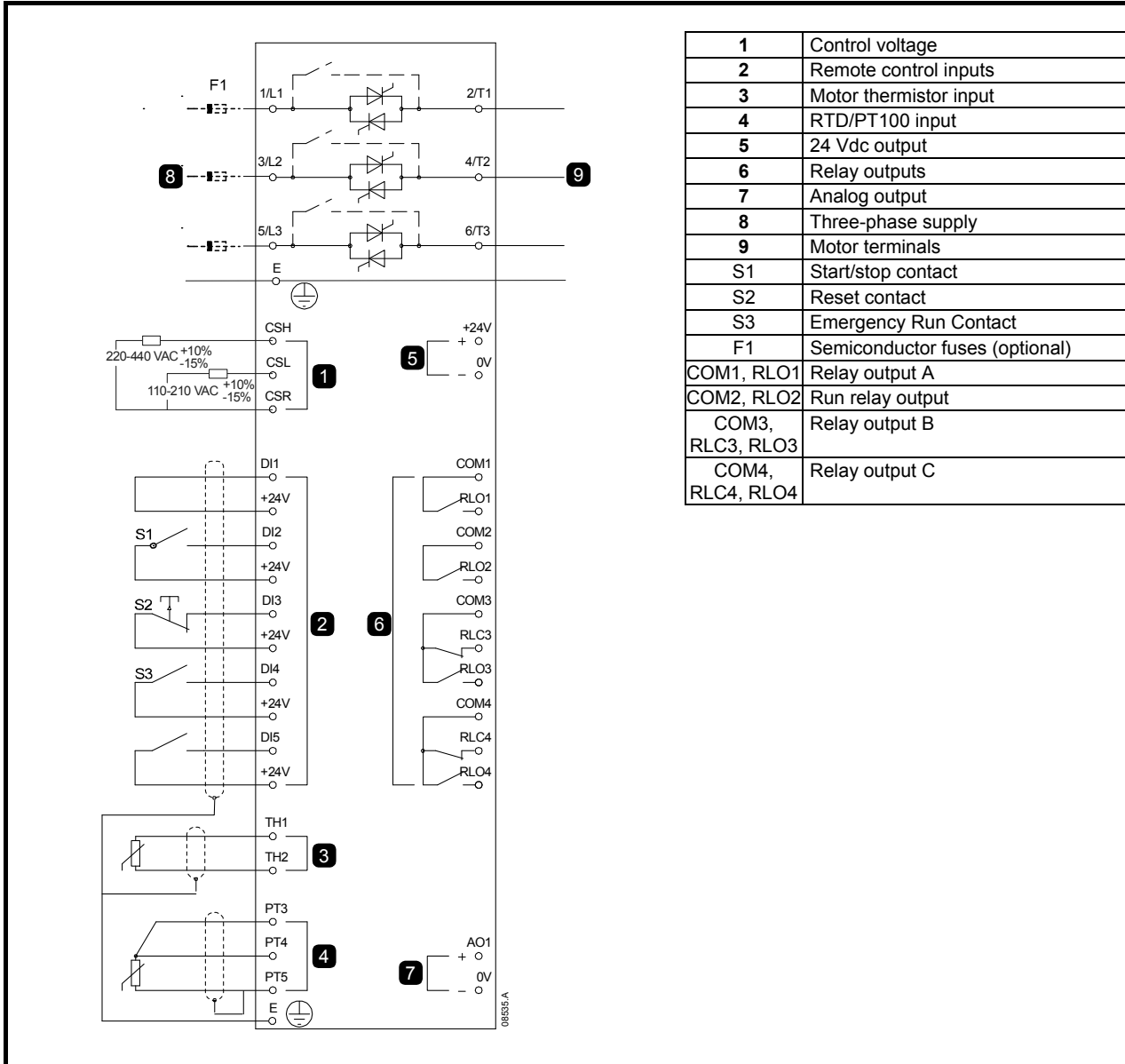

Parameter settings:

- Pr **3A Input A Function**
  - Select 'Emergency Run' - assigns Input A for Emergency Run function.
- Pr **15B Emergency Run**
  - Select 'Enable' - Enables Emergency Run mode.

## 10.4 Auxiliary trip circuit

In normal operation the Digistart D3 is controlled via a remote two wire signal (terminals DI2, +24V).

Input A (terminals DI4, +24V) is connected to an external trip circuit (such as a low pressure alarm switch for a pumping system). When the external circuit activates, the soft starter trips, which stops the motor.

**Figure 10-4 Auxiliary trip circuit**

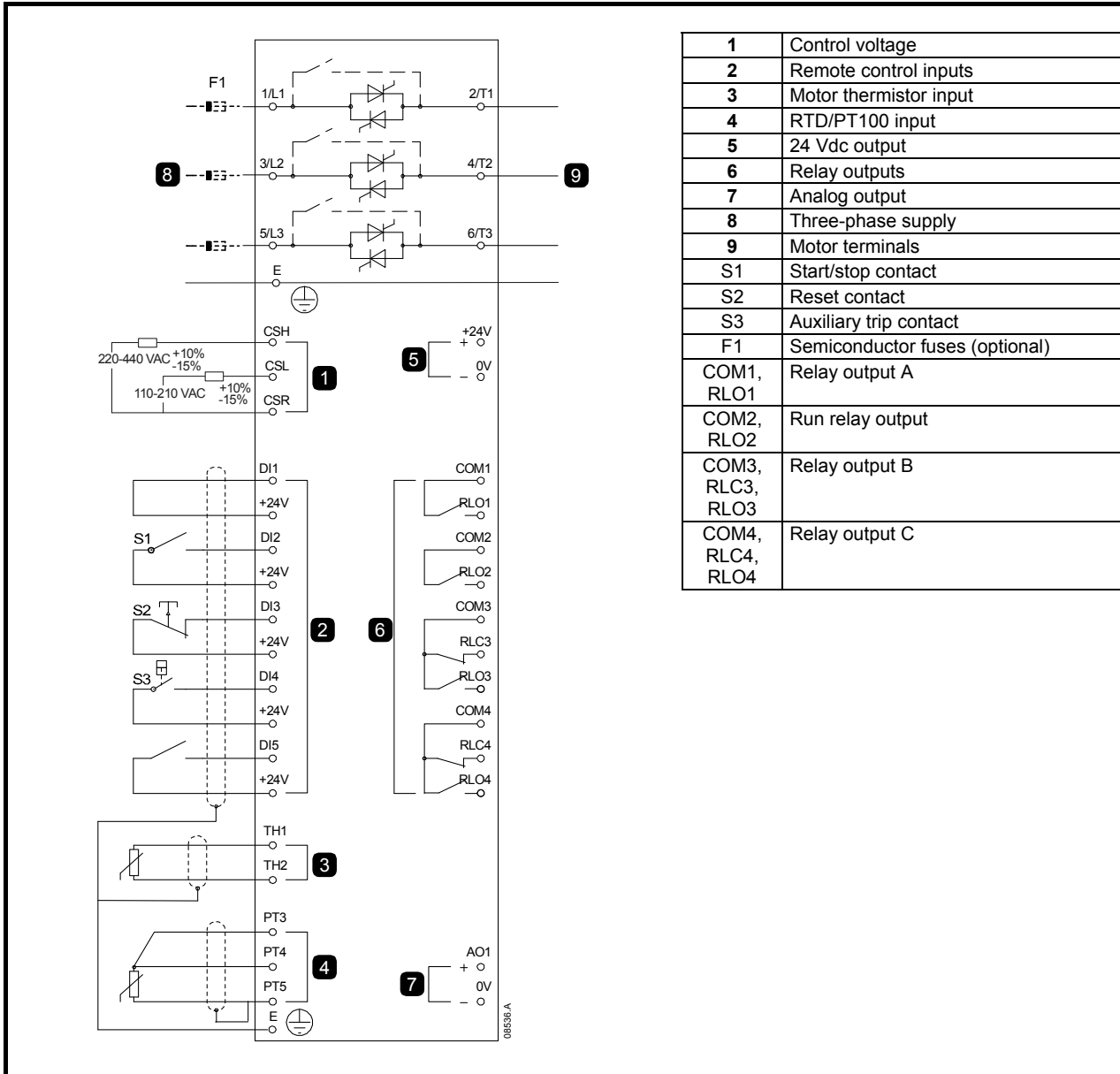

Parameter settings:

- **Pr 3A Input A Function**
  - Select 'Input Trip (N/O)'. Assigns the Input A to Auxiliary Trip (N/O) function.
- **Pr 3B Input A Name**
  - Select a name eg Low Pressure. Assigns a name to Input A.
- **Pr 3C Input A Trip**
  - Set as required. For example, 'Run Only' limits the input trip to when the soft starter is running only.
- **Pr 3E Input A Trip Delay**
  - Set as required. Sets a delay between the input activating and the soft starter tripping.
- **Pr 3D Input A Initial Delay**
  - Set at around 120 seconds. Limits operation of the input trip to 120 seconds after the start signal. This allows time for pressure to build up in the piping before the low pressure input becomes active.

## 10.5 DC brake with external zero speed sensor

For loads which may vary between braking cycles, there are benefits in using an external zero-speed sensor to interface with the Digistart D3 for brake shut-off. This control method ensures that the Digistart D3 braking will always shut off when the motor has reached a standstill, thus avoiding unnecessary motor heating.

The following schematic diagram shows how you can use a zero-speed sensor with the Digistart D3 to turn the brake function off at motor standstill. The zero-speed sensor (A2) is often referred to as an under-speed detector. Its internal contact is open at zero-speed and closed at any speed above zero-speed. Once the motor has reached a standstill, the DI4, +24V will open and the starter will be disabled. When the next start command is given (ie next application of K10), DI4, +24V closes and the Digistart D3 is enabled.

The Digistart D3 must be operated in remote mode and Pr **3A Input A Function** must be set to 'Starter Disable'.



If the brake torque is set too high, the motor will stop before the end of the brake time and the motor will suffer unnecessary heating which could result in damage. Careful configuration is required to ensure safe operation of the starter and motor.

A high brake torque setting can result in peak currents up to motor DOL being drawn while the motor is stopping. Ensure protection fuses installed in the motor branch circuit are selected appropriately.



Brake operation causes the motor to heat faster than the rate calculated by the motor thermal model. If you are using brake, install a motor thermistor or allow sufficient restart delay (Pr **6G**).

Figure 10-5 DC Brake with external zero speed sensor

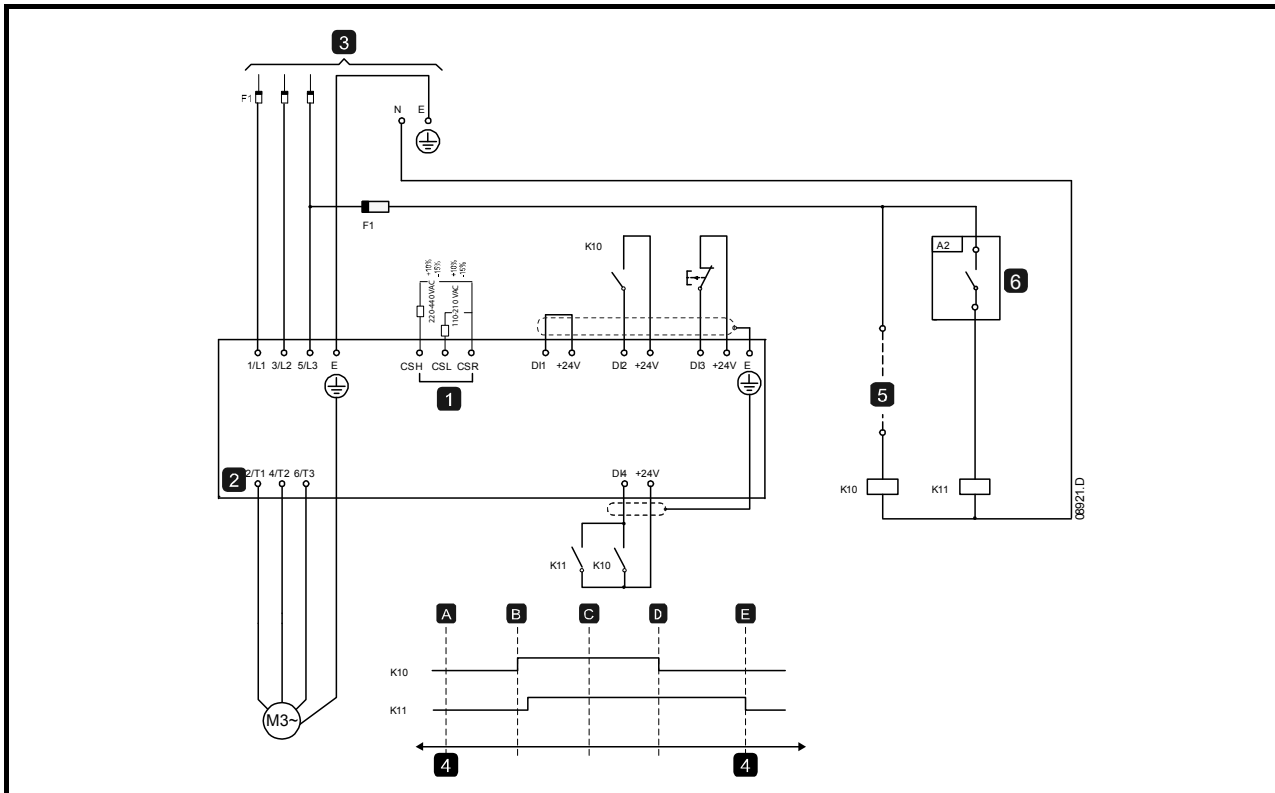

|           |  |
|-----------|--|
| 1         | Control voltage                            |
| DI1, +24V | Start                                      |
| DI2, +24V | Stop                                       |
| DI3, +24V | Reset                                      |
| DI4, +24V | Programmable input A (Starter Disable)     |
| 2         | Motor terminals                            |
| 3         | Three-phase supply                         |
| 4         | Starter Disable (shown on starter display) |

|   |                   |
|---|-------------------|
| A | Off (Ready)       |
| B | Start             |
| C | Run               |
| D | Stop              |
| E | Zero speed        |
| 5 | Start signal      |
| 6 | Zero speed sensor |

For details on configuring DC Brake, see *Brake* (page 42).



When using DC brake, the mains supply must be connected to the soft starter (input terminals L1, L2, L3) in positive phase sequence and Pr **5D Phase Sequence** must be set to Positive Only.

## 10.6 Soft braking

For applications with high inertia and/or a variable load, the Digistart D3 can be configured for soft braking.

In this application the Digistart D3 is employed with forward run and braking contactors. When the Digistart D3 receives a start signal (pushbutton S1), it closes the forward run contactor (K1) and controls the motor according to the programmed primary motor settings.

When the Digistart D3 receives a stop signal (pushbutton S2), it opens the forward run contactor (K1) and closes the braking contactor (K2) after a delay of approximately 2-3 seconds (K1T). K12 is also closed to activate the secondary motor settings, which should be user programmed for the desired stopping performance characteristics.

When motor speed approaches zero, the zero speed sensor (A2) stops the soft starter and opens the braking contactor (K2).

Figure 10-6 Soft braking

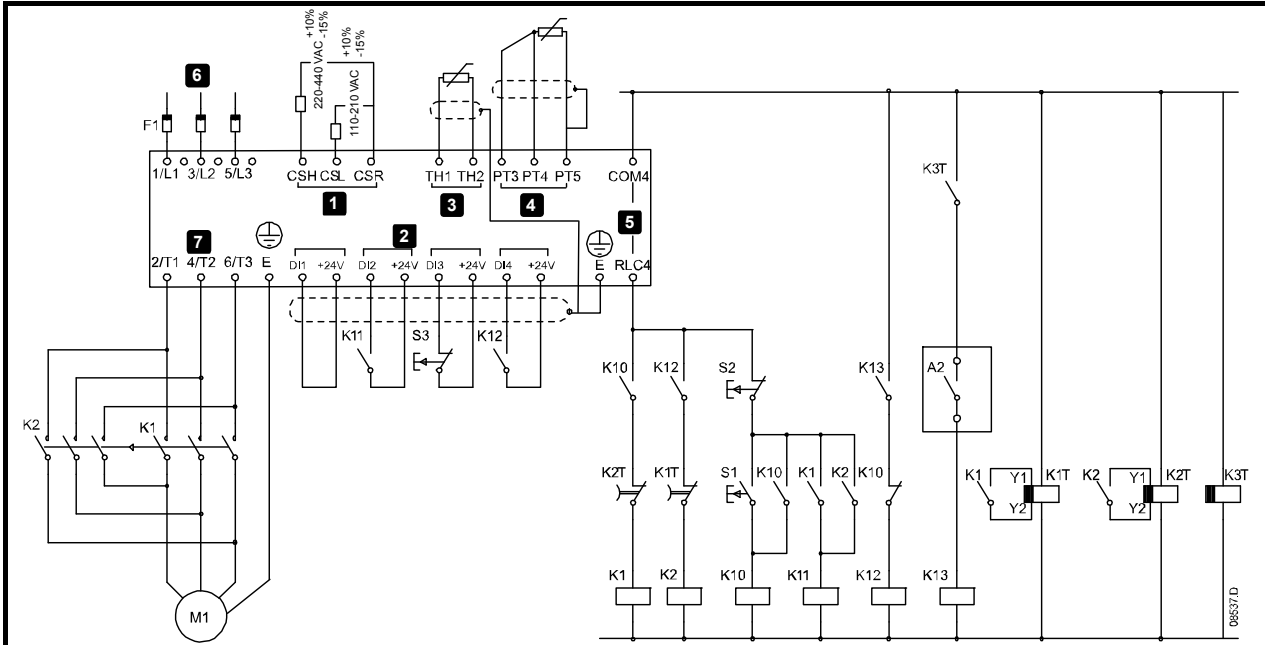

|            |                                |
|------------|--------------------------------|
| <b>1</b>   | Control voltage                |
| <b>2</b>   | Remote control inputs          |
| <b>3</b>   | Motor thermistor input         |
| <b>4</b>   | RTD/PT100 input                |
| <b>5</b>   | Relay outputs                  |
| <b>6</b>   | Three-phase supply             |
| <b>7</b>   | Motor terminals                |
| <b>A2</b>  | Zero speed sensor              |
| <b>F1</b>  | Semiconductor fuses (optional) |
| <b>K10</b> | Run relay                      |
| <b>K11</b> | Start relay                    |

|            |                                |
|------------|--------------------------------|
| <b>K12</b> | Brake relay                    |
| <b>K13</b> | Zero speed sensor relay        |
| <b>K1</b>  | Line contactor (Run)           |
| <b>K2</b>  | Line contactor (Brake)         |
| <b>K1T</b> | Run delay timer                |
| <b>K2T</b> | Brake delay timer              |
| <b>K3T</b> | Zero speed sensor delay timer* |
| <b>S1</b>  | Start contact                  |
| <b>S2</b>  | Stop contact                   |
| <b>S3</b>  | Reset contact                  |

\* The K3T timer is only required if the zero speed detector is the type that performs a self-test upon power-up and momentarily closes the output relay.

Parameter settings:

- Pr **3A Input A Function** (terminals DI4, +24V)
  - Select 'Motor Set Select' - assigns Input A for Motor set selection.
  - Set starting performance characteristics using the primary motor set.
  - Set braking performance characteristics using the secondary motor settings.
- Pr **4G Relay C Action**
  - Select 'Trip' - assigns Trip function to Relay Output C.

**NOTE** If the Digistart D3 trips on supply frequency (Pr **16H Frequency**) when the braking contactor K2 opens, modify the frequency protection settings.

## 10.7 Two-speed motor

The Digistart D3 can be configured for control of dual speed Dahlander type motors, using a high speed contactor (K1), low speed contactor (K2) and a star contactor (K3).

**NOTE** Pole Amplitude Modulated (PAM) motors alter the speed by effectively changing the stator frequency using external winding configuration. Soft starters are not suitable for use with this type of two-speed motor.

When the soft starter receives a high speed start signal, it closes the high speed contactor (K1) and star contactor (K3), then controls the motor according to the primary motor settings.

When the soft starter receives a low speed start signal, it closes the low speed contactor (K2). This closes Input A and the Digistart D3 controls the motor according to the secondary motor settings.

**Figure 10-7 Two-speed motor**

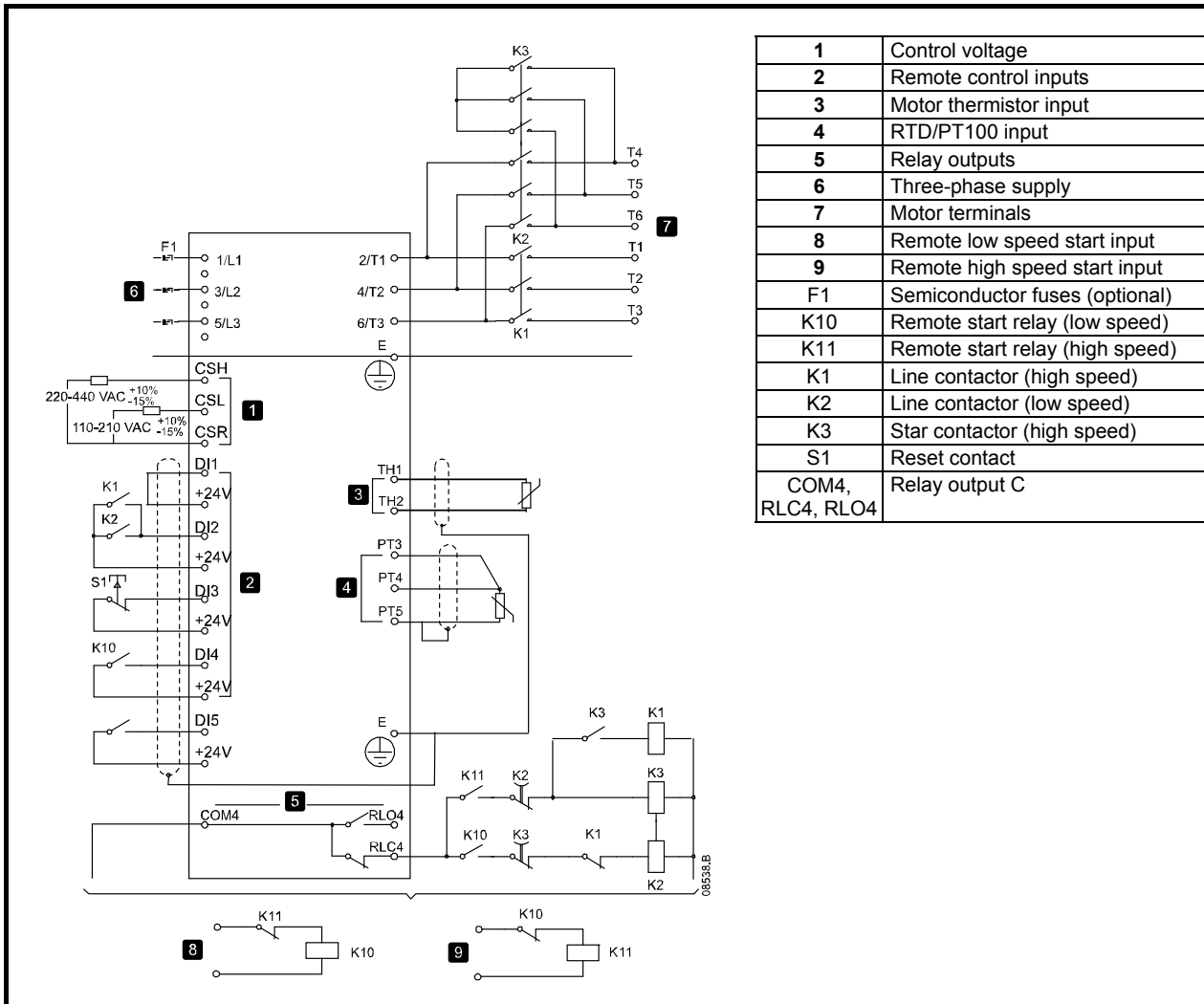

**NOTE** Contactors K2 and K3 must be mechanically interlocked.

Parameter settings:

- Pr **3A Input A Function** (terminals DI4, +24V)
  - Select 'Motor Set Select' - assigns Input A for Motor set selection.
  - Set high speed performance characteristics using the primary motor settings.
  - Set low speed performance characteristics using the secondary motor settings.
- Pr **4G Relay C Action**
  - Select 'Trip' - assigns Trip function to Relay Output C

**NOTE** If the Digistart D3 trips on supply frequency (Pr **16H Frequency**) when the high-speed start signal (9) is removed, modify the frequency protection settings.

## 10.8 Slip-ring motor

The Digistart D3 can be used to control a slip-ring motor, using rotor resistance.

Figure 10-8 Slip-ring motor

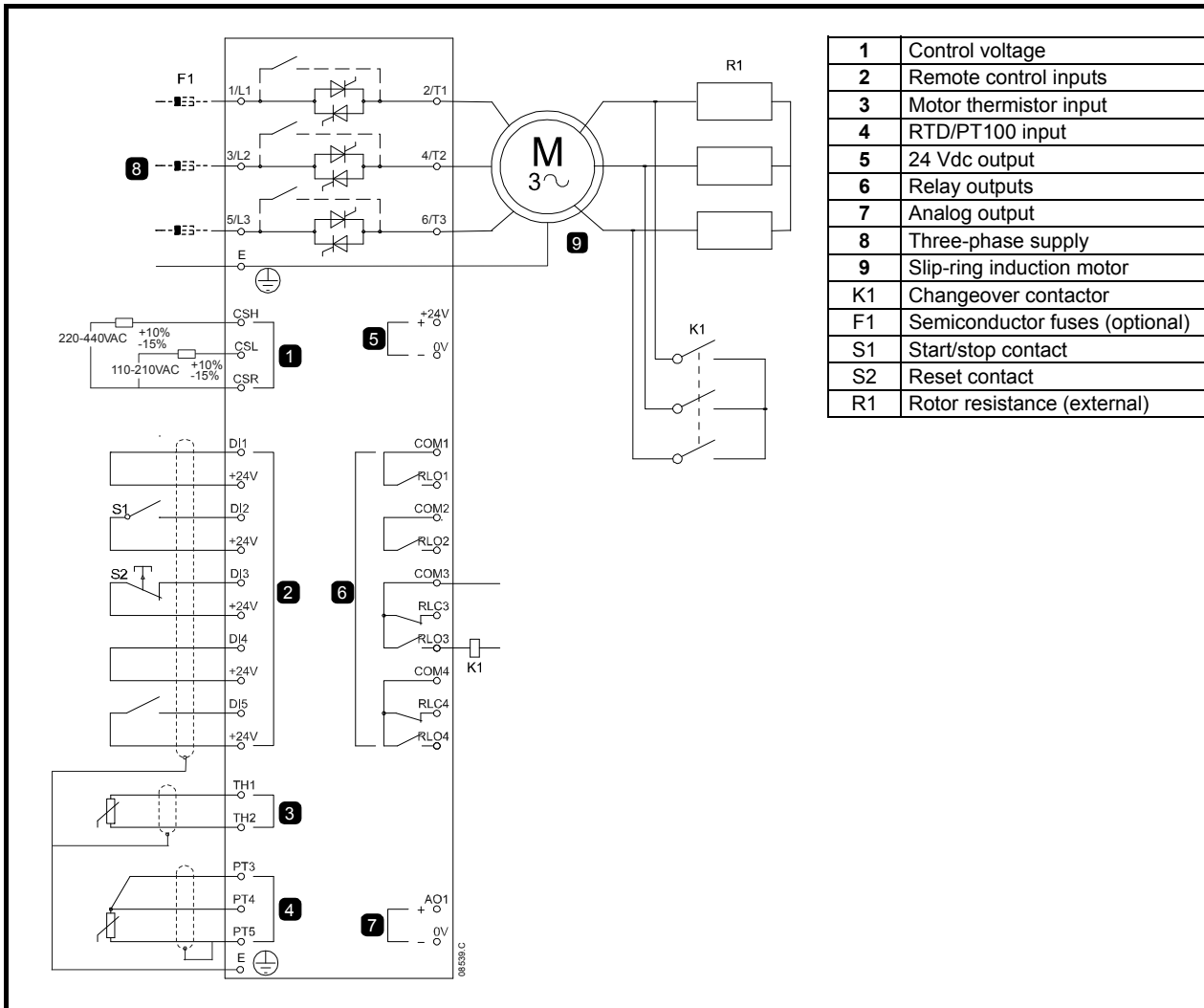

1. Configure the Digistart D3 as follows:

Parameter settings:

- Pr **4D Relay B Action**
    - Select 'Changeover contactor'
  - Pr **4E Relay B On Delay**
    - Set this to the maximum time (5m:00s).
  - Pr **13A Motor Data-1 Ramp**
    - Select 'Dual Ramp' (for slip-ring induction motor control)
  - Pr **13D Changeover Time**
    - Default setting is 150 milliseconds. Set this to a value just greater than the changeover contactor (K1) pole closing time.
  - Pr **13C Slip Ring Retard**
    - Default setting is 50%. Set this parameter to a value which is high enough to cause the motor to instantly accelerate once the rotor resistance (R1) has been bridged out and low enough to avoid a motor current pulse.
2. Start the motor under normal load conditions and record the time it takes to reach a constant speed with external rotor resistance (R1) in the circuit. Stop the motor soon after a constant speed has been reached. Change Pr **4E** to the recorded time value.
  3. Start the motor under normal load conditions and monitor the motor speed behaviour and motor current when the changeover contactor (K1) switches in to short-out the rotor resistance (R1).  
If the motor does not start to accelerate immediately after changeover, increase the setting of Pr **13C**.  
If there is a pulse in motor current immediately after changeover, reduce the setting of Pr **13C**.

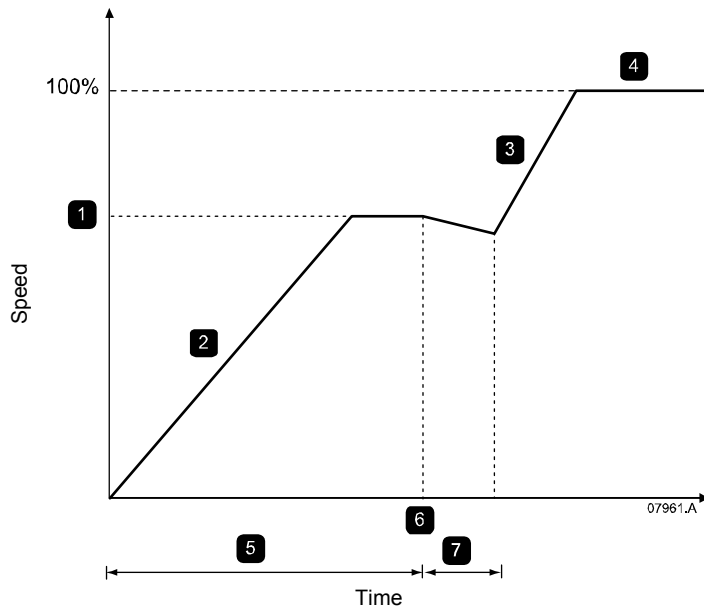

|          |                             |
|----------|-----------------------------|
| <b>1</b> | R1 Constant Speed           |
| <b>2</b> | First ramp                  |
| <b>3</b> | Second ramp                 |
| <b>4</b> | Run mode ( $I < 120\%$ FLC) |

|          |                        |
|----------|------------------------|
| <b>5</b> | Pr 4E Relay B On Delay |
| <b>6</b> | K1 closes              |
| <b>7</b> | Pr 13D Changeover Time |

**NOTE** For this installation to function correctly, only use the primary motor settings with constant current start method (Pr 2A Start Mode).

# 11. Technical Data

## Supply

|                                    |   |
|------------------------------------|---|
| Mains voltage (L1, L2, L3)         |   |
| D3-14-xxxx                         | 200 Vac to 440 Vac ( $\pm 10\%$ )   |
| D3-16-xxxx                         | 380 Vac to 600 Vac ( $\pm 10\%$ )   |
|                                    | or 380 Vac to 690 Vac ( $\pm 10\%$ ) for grounded star supply system only |
| Control voltage (CSH, CSL, CSR)    | 110 to 210 Vac or 220 to 440 Vac (+ 10% / -15%), 1 A                      |
| Recommended fuse                   | 1 A continuous (30 A max, 10 A typical half cycle inrush)                 |
| Mains frequency                    | 45 Hz to 66 Hz  |
| Rated insulation voltage to ground | 600 Vac   |
| Rated impulse withstand voltage    | 4 kV  |
| Form designation                   | Bypassed or continuous, semiconductor motor starter form 1                |

## Short circuit capability

|                                       |                            |
|---------------------------------------|----------------------------|
| Coordination with semiconductor fuses | Type 2                     |
| Coordination with HRC fuses           | Type 1                     |
| D3-1x-0023-B to D3-1x-0220-B          | prospective current 65 kA  |
| D3-1x-0255-B to D3-1x-1000-B          | prospective current 85 kA  |
| D3-1x-0255-N to D3-1x-0930-N          | prospective current 85 kA  |
| D3-16-1200-N to D3-16-1600-N          | prospective current 100 kA |

## Electromagnetic capability (compliant with EU Directive 89/336/EEC)

|               |                       |
|---------------|-----------------------|
| EMC Emissions | IEC 60947-4-2 Class B |
| EMC Immunity  | IEC 60947-4-2         |

## Inputs

|                             |  |
|-----------------------------|--|
| Input rating                | Active 24 Vdc, 8 mA approx   |
| Start (DI1, +24V)           | Normally Open  |
| Stop (DI2, +24V)            | Normally Closed  |
| Reset (DI3, +24V)           | Normally Closed  |
| Programmable inputs         |  |
| Input A (DI4, +24V)         | Normally Open  |
| Input B (DI5, +24V)         | Normally Open  |
| Motor thermistor (TH1, TH2) | Trip >3.6 k $\Omega$ , reset <1.6k $\Omega$  |
| PT100 RTD (PT3, PT4, PT5)   | Accuracy 0 to 100 °C $\pm 0.5$ °C, 100 °C to 150 °C $\pm 2$ °C, -20 to 0 °C $\pm 2$ °C |

## Outputs

|                            |   |
|----------------------------|---|
| Relay outputs              | 10A @ 250 Vac resistive, 5A @ 250 Vac AC15 pf 0.3 |
| Run relay (COM2, RLO2)     | Normally Open                                     |
| Programmable outputs       |   |
| Relay A (COM1, RLO1)       | Normally Open                                     |
| Relay B (COM3, RLC3, RLO3) | Changeover  |
| Relay C (COM4, RLC4, RLO4) | Changeover  |
| Analog output (AO1, 0V)    | 0-20 mA or 4-20 mA (selectable)                   |
| Maximum load               | 600 $\Omega$ (12 Vdc @ 20 mA)                     |
| Accuracy                   | $\pm 5\%$   |
| 24 Vdc output (+24V, 0V)   |   |
| Maximum load               | 200 mA  |
| Accuracy                   | $\pm 10\%$  |

## Environmental

|   |   |
|---|---|
| Protection  |   |
| D3-1x-0023-B to D3-1x-0105-B                                  | IP20  |
| D3-1x-0145-B to D3-1x-1000-B and D3-1x-0255-N to D3-16-1600-N | IP00  |
| Keypad (when installed with remote mounting kit)              | IP65 & NEMA12                               |
| Operating temperature   | -10 °C to 60 °C, above 40 °C with derating* |
| Storage temperature   | -25 °C to + 60 °C                           |
| Operating Altitude  | 0 - 1000 m, above 1000 m with derating      |
| Humidity  | 5% to 95% Relative Humidity                 |
| Pollution degree  | Pollution Degree 3                          |
| Vibration   |   |
| D3-1x-0023-B to D3-1x-1000-B                                  | IEC 60068-2-6                               |

\* Contact your local supplier for advice.

### Heat dissipation

|                                    |                             |
|------------------------------------|-----------------------------|
| During Start .....                 | 4.5 watts per ampere        |
| During Run                         |                             |
| D3-1x-0023-B to D3-1x-0053-B ..... | ≤ 39 watts approx           |
| D3-1x-0076-B to D3-1x-0105-B ..... | ≤ 51 watts approx           |
| D3-1x-0145-B to D3-1x-0220-B ..... | ≤ 120 watts approx          |
| D3-1x-0255-B to D3-1x-0500-B ..... | ≤ 140 watts approx          |
| D3-1x-0700-B to D3-1x-1000-B ..... | ≤ 357 watts approx          |
| D3-1x-0255-N to D3-1x-0930-N ..... | 4.5 watts per ampere approx |
| D3-16-1200-N to D3-16-1600-N ..... | 4.5 watts per ampere approx |

### Fan noise

|   |       |
|---|-------|
| D3-1x-0076-B to D3-1x-0220-B (excluding D3-1x-0170-B) ..... | 32 db |
| D3-1x-0255-B to D3-1x-1000-B .....                          | 49 db |
| D3-1x-0255-N to D3-1x-0430-N .....                          | 49 db |
| D3-1x-0650-N to D3-1x-0930-N .....                          | 56 db |
| D3-16-1200-N to D3-16-1600-N .....                          | 58 db |

### Certification

|  |  |
|--|--|
| C✓ .....   | IEC 60947-4-2                                    |
| CE .....   | IEC 60947-4-2                                    |
| RoHS .....   | Compliant with EU Directive 2002/95/EC           |
| UL / C-UL .....  | UL 508*  |
| D3-1x-0023-B to D3-1x-0425-B, D3-1x-0255-N to D3-16-1600-N ..... | UL Listed  |
| D3-1x-0500-B to D3-1x-1000-B .....                               | UL Recognised                                    |
| D3-1x-0023-B to D3-1x-0105-B .....                               | IP20 & NEMA1, UL Indoor Type 1                   |
| D3-1x-0145-B to D3-16-1600-N .....                               | IP00, UL Indoor Open Type                        |
| .....  | IP20, when fitted with optional finger guard kit |

\* For UL certification additional requirements may apply, depending on the models. For details, refer to *UL Compliant Installation* on page 87 for more information.

### Operational life (internal bypass contacts)

|                                    |                      |
|------------------------------------|----------------------|
| D3-1x-0023-B to D3-1x-0105-B ..... | 1,000,000 operations |
| D3-1x-0145-B to D3-1x-1000-B ..... | 100,000 operations   |



D3-1x-0220-B to D3-1x-1000-B: The contacts on the internal bypass contactors should be checked for wear after the stated number of operations. Periodic servicing/replacements may be required.

## 11.1 UL compliant installation

This section details additional requirements and configuration settings for the Digistart D3 soft starters to be UL compliant. Refer to also *UL Fuse Selection and Short Circuit Ratings* on page 31.

### 11.1.1 Models D3-1x-0023-B to D3-1x-0105-B

There is no additional requirement for these models.

### 11.1.2 Models D3-1x-0145-B to D3-1x-0220-B

- Use with applicable finger guard kit.
- Use the recommended pressure terminal/connector kit. Refer to *Terminal/Connector Parts* below for more information.

### 11.1.3 Models D3-1x-0255-B to D3-1x-0425-B

- Use with applicable finger guard kit.
- Use the recommended pressure terminal/connector kit. Refer to *Terminal/Connector Parts* below for more information.

### 11.1.4 Model D3-1x-0255-N

- Use the recommended pressure terminal/connector kit. Refer to *Terminal/Connector Parts* below for more information.

### 11.1.5 Models D3-1x-0360-N to D3-16-1600-N

- Configure the busbars for line / load terminals at opposite ends of the soft starter (i.e. Top In, Bottom Out or Top Out, Bottom In).
- Use the recommended pressure terminal/connector kit. Refer to *Terminal/Connector Parts* below for more information.

### 11.1.6 Models D3-1x-0500-B to D3-1x-1000-B

- Use with applicable finger guard kit.

These models are UL recognised components. Separate cable landing busbars may be required within the electrical cabinet when terminating cables sized according to the National Wiring Code (NEC) regulations.

### 11.1.7 Terminal/Connector Parts

For models D3-1x-0145-B to D3-1x-0425-B and D3-1x-0255-N to D3-16-1600-N to be UL compliant, you must use the recommended pressure terminal/connector as detailed in the table below. These parts are available from OhmPro.

**Table 11-1 UL compliant installation - Terminal/Connector parts**

| Models       | FLC (A) | No. of wires | Recommended lugs part No. |
|--------------|---------|--------------|---------------------------|
| D3-1x-0145-B | 145     | 1            | OPHD 95-16                |
| D3-1x-0170-B | 170     | 1            | OPHD 120-16               |
| D3-1x-0200-B | 200     | 1            | OPHD 150-16               |
| D3-1x-0220-B | 220     | 1            | OPHD 185-16               |
| D3-1x-0255-B | 255     | 1            | OPHD 240-20               |
| D3-1x-0350-B | 350     | 1            | OPHD 400-16               |
| D3-1x-0425-B | 425     | 2            | OPHD 185-16               |
| D3-1x-0255-N | 255     | 1            | OPHD 240-20               |
| D3-1x-0360-N | 360     | 2            | 1 x 600T-2                |
| D3-1x-0430-N | 430     |              |                           |
| D3-1x-0650-N | 650     |              |                           |
| D3-1x-0790-N | 790     | 4            | 2 x 600T-2                |
| D3-1x-0930-N | 930     | 3            | 2 x 600T-2                |
| D3-16-1200-N | 1200    | 4            | 1 x 750T-4                |
| D3-16-1410-N | 1410    |              |                           |
| D3-16-1600-N | 1600    | 5            | 1 x 750T-4<br>1 x 600T-3  |

## 12. Maintenance

**NOTE** The Digistart D3 soft starter is not user serviceable. The unit should only be serviced by authorised service personnel. Unauthorised tampering with the unit will void the product warranty.

- Before carrying out any work, disconnect and lock the starter's power supply and wait 2 minutes to ensure that the capacitors have discharged.
- When the starter trips, fatal residual voltages may remain at the output terminals and in the starter.
- During maintenance operations performed with the starter switched on, the operator must stand on an insulated surface which is not connected to ground.
- During work on a motor or its power supply cables, ensure that the power supply of the corresponding starter is disconnected and locked.
- Protective covers must remain in place during tests.

There are very few maintenance and repair operations for the user to perform on Digistart D3 soft starters. Regular servicing operations and simple methods for checking that the starter is operating correctly are described below.

### 12.1 Care

Printed circuits and internal components do not normally require any maintenance. Contact your local distributor or the nearest approved repair company in the event of a problem.



Do not dismantle the printed circuits while the starter is still under warranty. Unauthorised tampering with the unit will void the product warranty.

Do not touch the integrated circuits or the microprocessor either with your fingers or with materials which are charged or live. Ground yourself, as well as the workbench or the soldering iron, while performing any work on the circuits. From time to time, check that the power circuits are correctly tightened.

### 12.2 Measuring the motor current

The current drawn by the motor and the starter input current can be measured approximately using a conventional moving coil ammeter.

### 12.3 Measuring the input and output power

The starter input and output power can be measured using an electrodynamic instrument.



### 12.4 Exchanging products



Products must be returned in their original packaging or, if this is not possible, in similar packaging, to prevent their being damaged. Otherwise, replacement under warranty could be refused.

## 13. Options

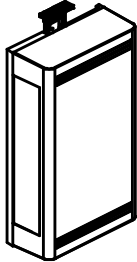
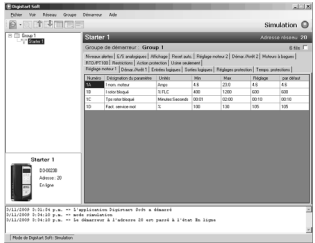
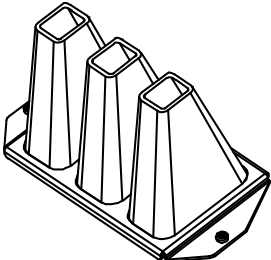
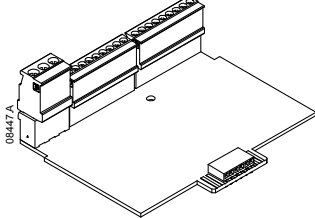
Table 13-1 Digistart D3 options

| Option name                                    | Function  | Picture   |
|--|---|---|
| Digistart - DeviceNet Interface                | Fieldbus communications modules   |    |
| Digistart - Ethernet IP Interface              |   |   |
| Digistart - Modbus Interface                   |   |   |
| Digistart - Modbus TCP Interface               |   |   |
| Digistart - Profibus Interface                 |   |   |
| Digistart - Profinet Interface                 |   |   |
| Digistart - USB Interface                      |   |   |
| Digistart-Soft                                 | <p>Digistart-Soft can be used with LEROY-SOMER soft starters to provide the following functionality for networks of up to 99 soft starters:</p> <ul style="list-style-type: none"> <li>Operational control (Start, Stop, Reset, Quick Stop)</li> <li>Starter status monitoring (Ready, Starting, Running, Stopping, Tripped)</li> <li>Performance monitoring (motor current, motor temperature)</li> </ul> <p>To use Digistart-Soft with the Digistart D3, the soft starter must be fitted with a Modbus or USB Module.</p> |    |
| Digistart D3 - Finger Guard                    | <p>Finger guards may be specified for personnel safety. Finger guards fit over the soft starter terminals to prevent accidental contact with live terminals. Finger guards provide IP20 protection when correctly installed.</p> <p><b>NOTE</b> Finger guards are required for models D3-1x-0145-B to D3-1x-0425-B to be UL compliant. Refer to <i>UL Compliant Installation</i> on page 87 for more information.</p>   |   |
| Digistart D3 - I/O Expansion                   | <p>The input/output expansion card provides the following additional inputs and outputs:</p> <ul style="list-style-type: none"> <li>2 x digital inputs</li> <li>3 x output relays</li> <li>1 x analog input</li> <li>1 x analog output</li> </ul>   |  |
| Digistart D3 - RTD/PT100 and Ground Fault Card | <p>The RTD/PT100 and ground fault protection card provides the following additional inputs:</p> <ul style="list-style-type: none"> <li>6 x PT100 RTD inputs</li> <li>1 x ground fault input</li> </ul> <p>To use ground fault protection a 1000:1, 5 VA current transformer is also required.</p>   |  |
| Digistart D3 - Keypad Mounting Kit             | <p>Allows remote mounting of the keypad up to 3 m away from the soft starter.</p> <p>Packing list: 1 x cable, 1 x gasket, 4 x screw M3, 4 x flat washer M3, 4 x spring washer M3, 4 x nut M3, 2 x jack screw, 1 x instructions.</p>   |  |

|                    |             |                         |                         |                   |                           |           |             |             |                      |                |             |         |
|--------------------|-------------|-------------------------|-------------------------|-------------------|---------------------------|-----------|-------------|-------------|----------------------|----------------|-------------|---------|
| Safety Information | Rating Data | Mechanical Installation | Electrical Installation | Keypad and Status | Quick Start Commissioning | Operation | Programming | Diagnostics | Application Examples | Technical Data | Maintenance | Options |
|--------------------|-------------|-------------------------|-------------------------|-------------------|---------------------------|-----------|-------------|-------------|----------------------|----------------|-------------|---------|





**EMERSON**<sup>™</sup>  
Industrial Automation