

Nidec

All for dreams

Installation & maintenance

Three-phase induction motors

LS/LSES, aluminium motors

FLS/FLSES, cast iron motors

CILS, cast iron motors



PLSES, IP23 drip-proof motors

Part number: 4850 en - 2026.05 / i

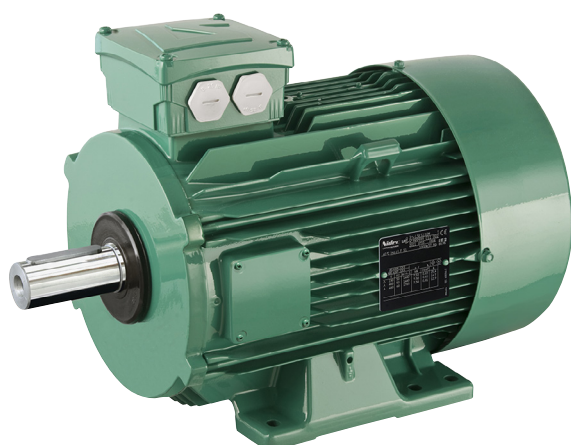
LEROY-SOMERTM



IMPORTANT

These symbols   appear in this document whenever it is important to take special precautions during installation, operation, maintenance or servicing of the motors.

It is essential that electric motors are installed by experienced, qualified and authorized personnel.

In accordance with the main requirements of EU Directives, the safety of people, animals and property should be ensured when fitting the motors into machines.

Particular attention should be given to equipotential ground or earthing connections.

The noise level of the machines, measured under standard conditions, conforms to the requirements of the standard.



The following preliminary precautions must be taken before working on any stationary device:

- **mains voltage disconnected and no residual voltage present**
- **careful examination of the causes of the stoppage (blocked transmission - loss of phase - cut-out due to thermal protection - lack of lubrication, etc)**

Dear Customer,

You have just acquired a Nidec Leroy-Somer motor.

This motor benefits from the experience of one of the largest manufacturers in the world, using state-of-the-art technology in automation, specially selected materials and rigorous quality control. As a result, the regulatory authorities have awarded our motor factories the ISO 9001 - Edition 2015 international certificate as well as ISO 14001:2015 certification, demonstrating our commitment to quality management and environmental protection.

We thank you for making this choice, and would ask you to read the contents of this manual.

By observing a few essential rules, you will ensure problem-free operation for many years.

Nidec Leroy-Somer

CE conformity

The motors comply with the Low Voltage Directive 2014/35/EU, the Electromagnetic Compatibility Directive 2014/30/EU, the ROHS II Directive 2011/65/EU and the ErP Directive 2009/125/EC, as well as all standards that refer to them.

Our products can be incorporated into machines subject to the Machinery Directive 2006/42/EC.

NOTE:

Nidec Leroy-Somer reserves the right to modify the characteristics of its products at any time in order to incorporate the latest technological developments. The information contained in this document may therefore be changed without notice.

Copyright 2026: Nidec Leroy-Somer

This document is the property of Nidec Leroy-Somer.

It may not be reproduced in any form without prior authorization.

All brands and models have been registered and patents applied for.

1 - RECEIPT	5
1.1 - Identification	5
1.2 - Storage	6
2 - ASSEMBLY	6
2.1 - Checking the insulation	6
2.2 - Location - ventilation	7
2.3 - Coupling	7
2.4 - Electrical guidelines	10
2.5 - Mains connection	13
3 - ROUTINE MAINTENANCE	16
3.1 - Greasing	16
3.2 - Bearing maintenance	16
4 - PREVENTIVE MAINTENANCE	17
5 - TROUBLESHOOTING GUIDE	18
6 - CORRECTIVE MAINTENANCE: GENERAL	19
6.1 - Dismantling the motor	19
6.2 - Checks before reassembly	19
6.3 - Mounting the bearings on the shaft	19
6.4 - Reassembling the motor	19
6.5 - Reassembling the terminal box	19
7 - POSITION OF LIFTING RINGS	20
8 - SPARE PARTS	21
9 - RECYCLING	21
10 - LS/LSES MOTORS	24
10.1 - LS/LSES 71 to 160 MP/LR motors	24
10.2 - LS/LSES 160 M/L/LU, 180 MT/LR motors	26
10.3 - LS/LSES 180 L/LUR, 200 L/LR/LU, 225 ST/MT/MR, 250 MZ motors	28
10.4 - LS/LSES 225 MG, 250 ME/MF, 280 SC/MC/SD/MD, 315 SN motors	30
10.5 - LS/LSES 280 SU/SK/MK, 315 (except SN) motors	32
11 - FLS/FLSES MOTORS	34
11.1 - FLS/FLSES 80 to 132 motors	34
11.2 - FLS/FLSES 160, 180 MR motors	36
11.3 - FLS/FLSES 180 M/L/LUR, 200 LU, 225 MR/SR motors	38
11.4 - FLS/FLSES 225 M to 280 motors	40
11.5 - FLS/FLSES 315 to 355 LD motors	42
12 - CILS MOTORS	44
12.1 - CILS 225 motors	44
12.2 - CILS 250 motors	46
12.3 - CILS 280 to 315 motors	48
13 - PLSES MOTORS	50
13.1 - PLSES 225 MG, 250, 280 SC/SD/MC/MD/MF motors	50
13.2 - PLSES 280 MG/SG, 315 motors	52
13.3 - PLSES 315 LG/MGU to VLGU, PLSES 355 motors	54

1 - RECEIPT

On receipt of your motor, check that it has not suffered any damage in transit.

If there are obvious signs of knocks, contact the carrier (you may be able to claim on their insurance) and after a visual check, turn the motor by hand to detect any malfunction.

1.1 - Identification

As soon as you receive the motor, check that the nameplate on the machine conforms to your order.

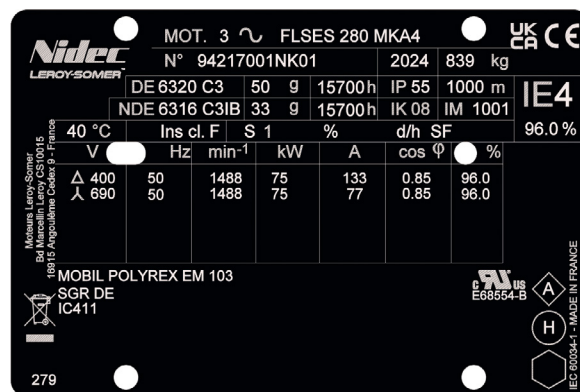
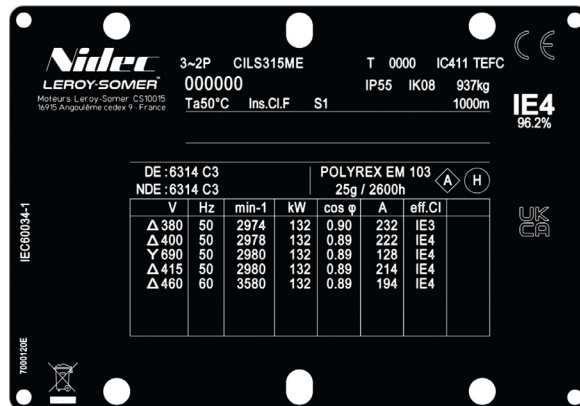
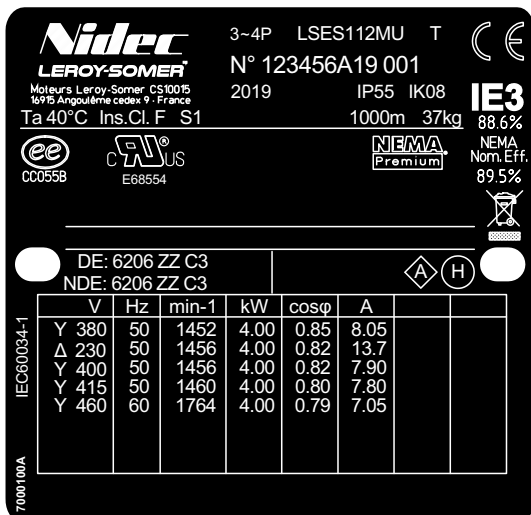

* Other logos may be used as an optional extra:
This must be agreed prior to ordering.

Definition of symbols used on nameplates:



Legal mark of conformity of product to the requirements of European Directives

- MOT 3 ~** : 3-phase A.C. motor
- LSES** : Series
- 112** : Frame size
- MU** : Housing symbol
- B3** : Mounting position

- Motor no.**
- 123456** : Motor batch number
 - A** : Month of production
 - 19** : Year of production
 - 001** : Serial number
 - IE3** : Efficiency class
 - 88.6%** : Efficiency at 4/4 load

- IP55 IK08** : Index of protection
- Ins. cl. F** : Insulation class F
- Ta 40°C** : Ambient operating temperature
- S1** : Duty - Duty (operating) factor
- 1000m** : Max. altitude, without derating
- kg** : Weight
- V** : Supply voltage
- Hz** : Supply frequency
- min⁻¹** : Revolutions per minute (rpm)
- kW** : Rated output power
- cos φ** : Power factor
- A** : Rated current
- Δ** : Delta connection
- Y** : Star connection

Bearings

- DE** : Drive end bearing
- NDE** : Non drive end bearing
- g** : Amount of grease at each regreasing (in g)
- h** : Regreasing interval (in hours)

POLYREX EM103 : Type of grease

- A** : Vibration level
- H** : Balancing mode

Please quote when ordering spare parts

1.2 - Storage

Prior to commissioning, machines should be stored in a horizontal position :

- Away from humidity: at relative humidity levels greater than 90%, the state of the anti-rust protection on unpainted parts should be monitored. The motor may be placed in a sealed enclosure with desiccant bags inside.
- Away from frequent significant variations in temperature, to avoid the risk of condensation. Drain plugs may be removed to allow condensation water to escape.
- If the area is subject to vibration, place the motor on a damping support (rubber plate or equivalent)
- To prevent grease migration and premature bearing degradation caused by prolonged standstill, rotate the shaft manually at regular intervals, at least once every quarter.
- Do not remove the rotor locking device (in the case of roller bearings). It shall only be released during rotor rotation operations.

Even if the motor has been stored in the correct conditions, certain checks must be carried out before it is started up:

Greasing

Bearings which cannot be regreased

Maximum storage: 3 years. After this time, replace the bearings (see section 6.3).

Bearings which can be regreased

	Grease grade 2	Grease grade 3	
Storage period	less than 6 months	less than 1 year	The motor can be commissioned without regreasing.
	more than 6 months less than 1 year	more than 1 year less than 2 years	Regrease before commissioning, as described in section 3.1
	more than 1 year less than 5 years	more than 2 years and less than 5 years	Dismantle the bearing - Clean it - Replace the grease completely
	more than 5 years	more than 5 years	Change the bearing - Regrease it completely

Grease used by NIDEC LEROY-SOMER (see nameplate): - POLYREX EM103

2 - ASSEMBLY

In all cases, compatibility of the motor and its environment must be guaranteed before its installation and also throughout its life.

 Electric motors are industrial products. They must therefore be installed by qualified, experienced and authorized personnel. The safety of people, animals and property must be ensured when fitting the motors into machines (please refer to current standards).

2.1 - Checking the insulation

 Before starting the motor, it is advisable to check the insulation between the phases and earth, and between phases.

This check is essential if the motor has been stored for longer than 6 months or if it has been kept in a damp atmosphere. This measurement must be carried out using a megohmmeter at 500V D.C. (do not use a magnetoelectric system).

It is better to carry out an initial test at 30 or 50 volts and if the insulation is greater than 1 megohm, carry out a second test at 500 volts for 60 seconds. The insulation value must be at least 10 megohms in cold state.

If this value cannot be achieved, or if the motor may have been splashed with water or salt spray, or kept for a long period in a very humid place or if it is covered with condensation, it is advisable to dry the stator for 24 hours in a drying oven at a temperature of between 110°C and 120°C.

If it is not possible to place the motor in a drying oven:

- Switch on the motor, with the rotor locked, at 3-phase A.C. voltage reduced to approximately 10% of the rated voltage, for 12 hours (use an induction regulator or a reduction transformer with adjustable outlets).
- Or supply the 3 phases in series with a D.C. current, with the voltage at 1 to 2% of the rated voltage (use a D.C. generator with independent excitation or batteries for motors of less than 22 kW).

- NB: The A.C. current must be monitored using a clamp ammeter, and the D.C. current using a shunt ammeter. This current must not exceed 60% of the rated current.

It is advisable to place a thermometer on the motor housing: if the temperature exceeds 70 °C, reduce the indicated voltage or current by 5% of the original value for every 10° difference. While it is drying, all the motor orifices must be open (terminal box, drain holes).

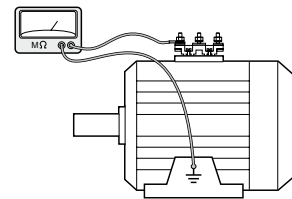

For all insulation or dielectric tests, it is advisable to earth the thermal probes and/or accessories.

 **Warning:** If the high voltage test, carried out at the factory before dispatch, needs to be repeated, it should be performed at half the standard voltage, i.e.: 1/2 (2U+1000V). Check that the capacitive effect resulting from the high voltage test is eliminated before connecting the terminals to earth.

**⚠ Prior to commissioning for all motors:
Rotate the motor at no load (no mechanical load)
for 2 to 5 minutes, checking that there is no abnormal
noise. If there is any abnormal noise, see section 5.**

2.2 - Location - ventilation

2.2.1 - TEFV motors

Our motors are cooled in accordance with method IC 411 (standard IEC 60034-6), i.e. «machine cooled by its surface, using the ambient fluid (air) flowing along the machine».

The fan at the non drive end cools the motor. Air is sucked in through the grille of a fan cover (which provides protection against the risk of direct contact with the fan in accordance with standard IEC 60034-5) and blown along the housing fins to ensure thermal equilibrium of the motor whatever the direction of rotation.

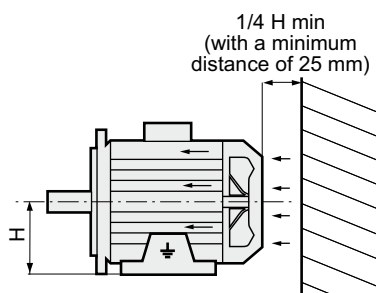

2.2.2 - Drip-proof motors

Location ventilation

Our motors are cooled in accordance with method IC 01 (standard IEC 60034-6), i.e. «machine cooled by means of the ambient fluid (air) circulating inside the machine».

A fan at the non-drive end cools the motor. Air is sucked in at the front of the motor and blown along the fan cover to ensure thermal equilibrium of the motor whatever the direction of rotation.

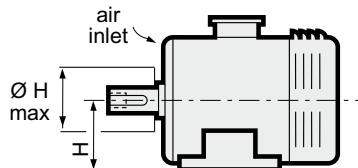

The motor must be installed in an adequately ventilated area, with clearance for the air intake and outlet of at least onequarter of the frame size.

Obstruction (clogging) - even accidental - of the fan cover grille has an adverse effect on motor operation.

In the case of vertical operation with the shaft extension facing down, it is advisable to fit the motor with a drip cover to prevent penetration by any foreign bodies.

It is also necessary to check that the hot air is not being recycled. If it is, pipes must be provided for the intake of cold air and the discharge of hot air, in order prevent abnormal motor temperature rise.

In this case, if the air is not circulated by an auxiliary fan, the dimensions of the pipes must be such that the pressure losses are negligible compared to those of the motor.

Positioning

The motor must be mounted in the position specified on the order, on a base which is rigid enough to prevent distortion and vibration.

Where the motor feet have six fixing holes, it is preferable to use those which correspond to the standard dimensions for the motor power rating (refer to the technical catalogue for induction motors), or, failing that, to those shown at B2.

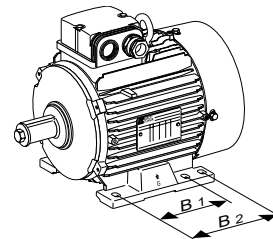

Ensure there is easy access to the terminal box, the condensation drain plugs and, if appropriate, to the grease nipples. Use lifting equipment which is compatible with the weight of the motor (indicated on the nameplate).

⚠ When the motor is fitted with lifting rings, they are for lifting the motor on its own and must not be used to lift the whole machine after the motor has been fitted to it.

Note 1: When installing a suspended motor, it is essential to provide protection in case the fixing breaks.

Note 2: Never stand on the motor.

2.3 - Coupling

Preparation

Turn the motor by hand before coupling to detect any possible fault due to handling.

Remove any protection from the shaft extension.

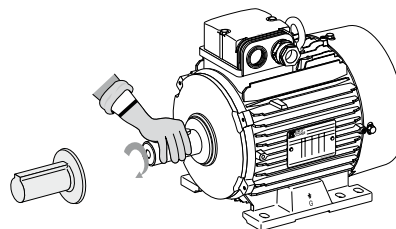

Drain off any condensation water which may have formed inside the motor by removing the plugs from the drain holes and fit them back to keep the IP level.

Rotor locking device

For made-to-order motors with roller bearings, remove the rotor locking device.

In exceptional circumstances when the motor has to be moved after the coupling device has been fitted, the rotor must be re-immobilised.

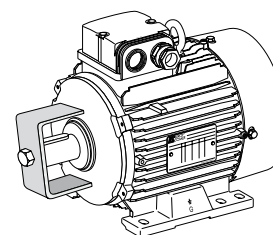

Balancing

Rotating machines are balanced in accordance with standard ISO 21940-32 : 2012:

- Half-key when the shaft extension is marked H
- No key when the shaft extension is marked N.
- Full key when the shaft extension is marked F.

and any coupling element (pulley, coupling sleeve, slip-ring, etc) must therefore be balanced accordingly. To find out the motor balancing type, look at its nameplate.

The motors are balanced with a half-key as standard unless otherwise indicated. The coupling balancing will therefore need to be adapted to the motor balancing, and the coupling will need to be adapted to the length of the shaft key; alternatively any visible parts protruding from the key can be machined off. An adapted key can be used.

Failure to follow these recommendations could lead to premature wear of the bearings and invalidate the warranty.

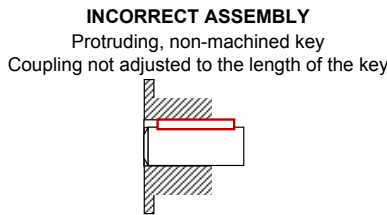
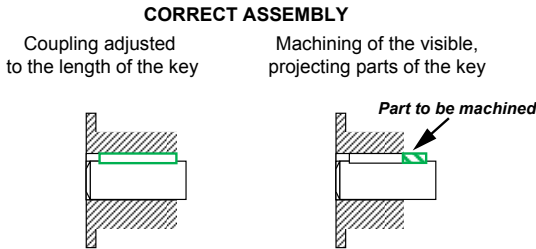

Motor with 2 shaft extensions:

If the second shaft extension is not used, in order to comply with the balancing class, the key or half-key must be fixed firmly in the keyway so that it is not thrown out during rotation (H or F balancing) and must be protected against direct contact.

Precautions

All measures must be taken to ensure protection against the risks which arise when there are rotating parts (coupling sleeve, pulley, belt etc).

If a motor is started up without a coupling device having been fitted, carefully immobilize the key in its location.

Beware of backdriving when the motor is switched off. The appropriate precautions must be taken:

- For pumps, a non-return valve must be installed.
- For mechanical devices, install a backstop or a holding brake.
- etc..

Tolerances and adjustments

The standard tolerances are applicable to the mechanical characteristics given in our catalogues. They comply fully with the requirements of IEC standard 60072-1 : 2022.

- Users must adhere strictly to the instructions provided by the transmission device supplier.

- Avoid impacts which could damage the bearings.
- Use a spanner and the tapped hole of the shaft end with a suitable lubricant to make it easier to fit the coupling.

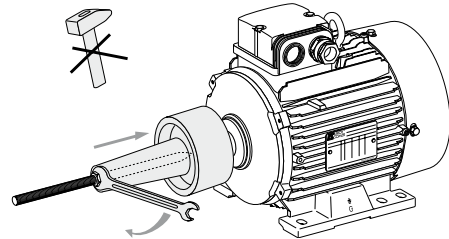

- The hub of the transmission device must be:
- Fully in contact with the shoulder of the shaft or, if this is missing, against the metal stop ring which forms a labyrinth seal and thus locks the bearing in place (do not crush the seal).
 - Longer than the shaft extension (2 to 3 mm) so that it can be tightened using a screw and washer. If it is not, a spacer ring must be inserted without cutting the key (if this ring is large, it must be balanced).

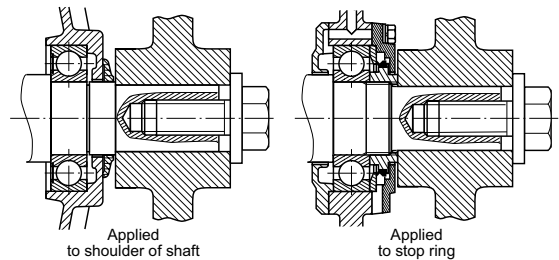

If there is a second shaft extension, it must only be used for direct coupling and the same recommendations must be followed.

The 2nd shaft extension may also be smaller than the main shaft extension, and under no circumstances can it deliver torques greater than half the rated torque.

The inertia flywheels device must not be mounted directly onto the shaft extension, but installed between end shield and device using a coupling.

Mounting a face mounted motor

Mounting face mounted motors IM B14 (IM 3601) and IM B34 (IM 2101).

Max. screw insertion length when mounting face mounted motors IM B34 and IM B14.

	Max. insertion (mm)
LSES 71 F75 M5 / F85 M6	13
LSES 80 F100 M6	11
LSES 90 F115 M8	11
LSES 100 F130 M8	11
LSES 112 F130 M8	11
LSES 132 F215 M12	11
LSES 160 F215 M12	15

Direct connection onto the machine

When the mobile device (pump or fan turbine) is mounted directly on the motor shaft extension, check that this device is perfectly balanced and that the radial force and the axial thrust are within the limits indicated in the catalogue for the bearing withstand.

Direct connection using a flexible coupling

Selection of the coupling sleeve should take account of the rated torque to be transmitted and the safety factor dependent on the starting conditions for the electric motor.

The machines must be carefully aligned, so that any lack of concentricity and parallelism in the two coupling halves is compatible with the recommendations of the coupling sleeve manufacturer.

Both parts of the coupling should be provisionally assembled to make it easier to alter their relative position.

Adjust the parallel plane of both shafts using a gauge.

Measure the distance between the two coupling surfaces at one point on the circumference. Rotate them 90°, 180° and 270° in relation to this initial position, and measure each time.

The difference between the two extremes of the value «x» must not exceed 0.05 mm for standard couplings.

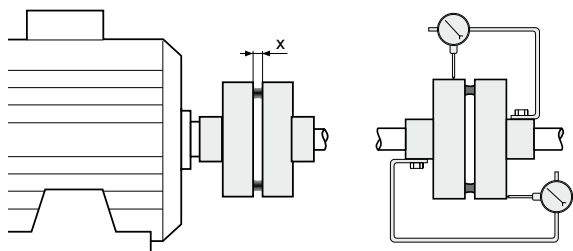

To perfect this adjustment and at the same time check the concentricity of the two shafts, fit 2 gauges as shown in the diagram and slowly turn both shafts.

The deviations registered by either shaft will indicate the need for either an axial or radial adjustment if the deviation exceeds 0.05mm.

Direct connection using a rigid coupling

Both shafts must be aligned so as to adhere to the tolerances of the coupling sleeve manufacturer.

Maintain the minimum distance between the two shaft extensions to allow for expansion of the motor shaft and the load shaft.

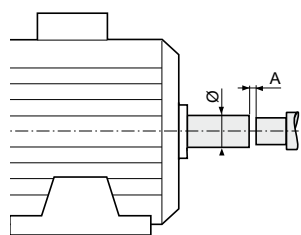

Ø (mm)	A (mm) min.
9 to 55	1
60	1.5
65	1.5
75	2
80	2

Transmission via belt pulleys

The user can choose the diameter of the pulleys.

Cast iron pulleys with a diameter greater than 315 are not recommended for rotation speeds of 3000 min⁻¹.

Flat belts cannot be used for rotation speeds of 3000 min⁻¹ or more.

Positioning the belts

So that the belts can be correctly positioned, allow for possible adjustment of approximately 3% with respect to the calculated distance E.

Force must never be used when fitting the belts.

For notched belts, position the notches in the pulley grooves.

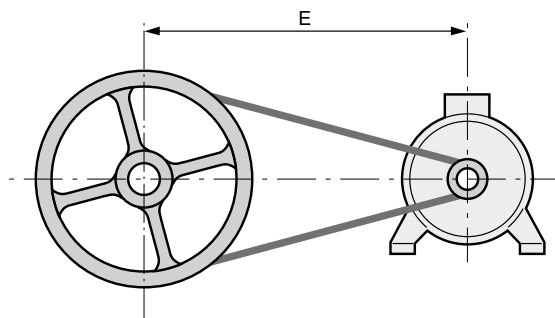

Aligning the pulleys

Check that the motor shaft is completely parallel with that of the receiving pulley.

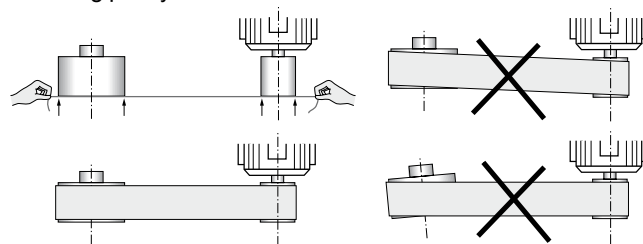

Protect all rotating devices before power-up.

Adjusting the tension of the belts

The tension of the belts must be adjusted very carefully in accordance with the recommendations of the belt supplier and the calculations made when the product was specified.

Reminder:

- Tension too great = unnecessary force on the end shields which could lead to premature wear of the bearing unit (end shield-bearings) and eventually break the shaft.
- Too little tension = vibration (wearing of the bearing unit).

Fixed distance between centers:

Place a belt tensioning pulley on the slack side of the belts:

- Smooth pulley on the outside of the belt
- Grooved pulley on the inside of the belts when using V-belts.

Adjustable distance between centers:

The motor is usually mounted on slide rails, which enables optimum adjustment of the pulley alignment and the belt tension.

Place the slide rails on a perfectly horizontal baseplate.

The lengthways position of the slide rails is determined by the length of the belt, and the crossways position by the pulley of the machine being driven.

Mount the slide rails firmly with the tension screws in the direction shown in the diagram (the slide rail screw on the belt side between the motor and the machine being driven).

Fix the slide rails onto the baseplate and adjust the belt tension as before.

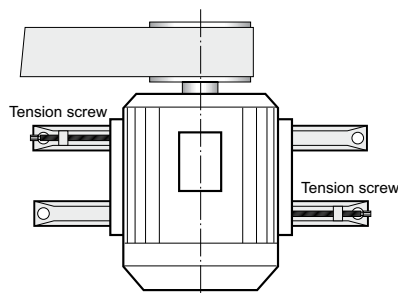

2.4 - Electrical guidelines

2.4.1 - Limiting problems caused by motor starting

In order to protect the installation, any significant temperature rise in the cabling conduits must be prevented, while ensuring that the protection devices do not interrupt starting.

Operating problems in other equipment connected to the same supply are due to the voltage drop caused by the current demand on starting - many times greater than the current absorbed by the motor at full load (approximately 7), see the Induction motors technical catalogue ref.5147.

Even though the mains supplies increasingly allow D.O.L. starting, the current inrush must be reduced for certain installations.

Jolt-free operation and soft starting ensure greater ease of use and an increased lifespan for the machines being driven.

The two essential parameters for starting cage induction motors are:

- starting torque
- starting current

The starting torque and the resistive torque determine the starting time.

Depending on the load driven, it may be necessary to adapt starting torque and current depending on the mains power supply characteristics.

The five essential modes are:

- D.O.L. starting
- Star/delta starting
- Soft starting with autotransformer
- Soft starting with resistors
- Electronic starting

The «electronic» starting modes control the voltage at the motor terminals during the entire starting phase and enable very soft, jolt-free starting.

2.4.2 - NIDEC LEROY-SOMER «Digistart» electronic starter

This is a multi-function electronic system with a microcontroller, which is used with all 3-phase cage induction motors.

It provides soft starting of the motor with:

- Reduction of the starting current
- Gradual, jolt-free acceleration, achieved by controlling the current absorbed by the motor.

After starting, the DIGISTART performs additional motor control functions in its other operating phases: steady state and deceleration.

- 24 to 1250 A models
- Supply: 200 to 690 V

DIGISTART is economical to install, as a fused switch is the only additional device needed.

2.4.3 - Other control systems

Special precautions need to be taken when standard induction motors are being used for variable speed control, powered by a frequency inverter or voltage controller. For further information, please refer to the Guide to best practices Motor-drive systems ref.5626 (www.leroy-somer.com).

During prolonged operation at low speed, cooling efficiency is greatly diminished. It is therefore advisable to install a forced ventilation unit that will produce a constant flow of air independently of the motor speed.

In prolonged operation at high speed, the fan may make excessive noise. It is again advisable to install a forced ventilation system.

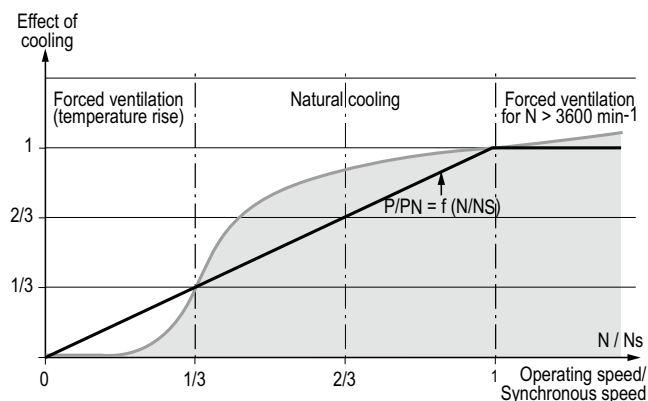

If the frequency exceeds 50 Hz:

- a - Carefully check that all the components on a particular transmission are properly aligned.
 - b - The voltage remains constant above 50 Hz.
 - c - The power supplied by the motor up to 60 Hz remains constant (make sure that the power absorbed by the load does not vary differently in this frequency range).
 - d - Check that the application speed does not exceed the synchronous speed values:
 - 2P --> 3600 min⁻¹ motors
 - 4P --> 1800 min⁻¹ motors
 - 6P --> 1200 min⁻¹ motors
 - e - For all other frequency and/or voltage limits, additional precautions must be taken for derating, bearings, ventilation, noise, etc: please consult Leroy-Somer.
- Check that the vibration level of the assembled machine complies with standard ISO 20816-3:2022.

The user is responsible for protecting the motor and drive equipment from hazardous currents and overvoltages in the winding. For further information, please refer to the Guide to best practices Motor-drive systems ref.5626 (www.leroy-somer.com).

2.4.4 - Permissible starting times and locked rotor times

The starting times must remain within the limits stated below on condition that the number of starts per hour is 6 or less. Three successive cold starts and two consecutive warm starts are allowed.

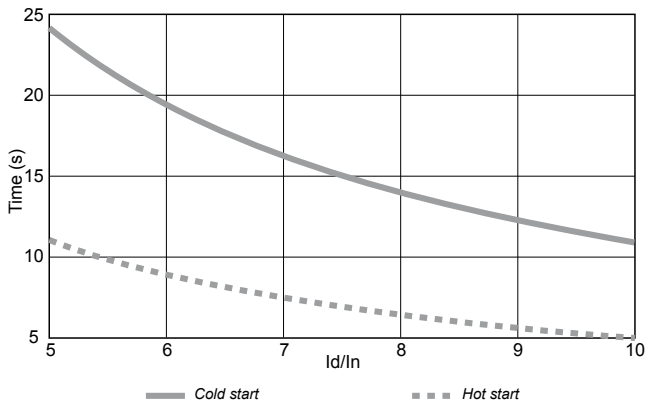

Permissible motor starting time in relation to the ratio I_D/I_N

2.4.5 - Earthing (see section 2.5.5)

2.4.6 - Power factor compensation capacitors



Before any work is carried out on the motor or in the cabinet, check that the capacitors are isolated and/or discharged (read the voltage at the terminals).

2.4.7 - Motor protection devices

2.4.7.1 - On-line protection

Adjusting the thermal protection

It should be adjusted to the value of the current read on the motor nameplate for the connected mains voltage and frequency.

Thermal magnetic protection

The motors must be protected by a thermal magnetic device located between the isolating switch and the motor. These protection devices provide total protection of the motor against non-transient overloads.

This device can be accompanied by fused circuit-breakers.

Built-in direct thermal protection

For low rated currents, bimetallic strip-type protection may be used. The line current passes through the strip, which shuts down or restores the supply circuit as necessary. The design of this type of protection allows for manual or automatic reset.



2.4.7.2 - Built-in indirect thermal protection

The motors can be equipped with optional heat sensors.

These sensors can be used to monitor temperature changes at "hot spots":

- overload detection
- cooling check
- Monitoring strategic points for maintenance of the installation

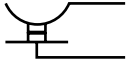
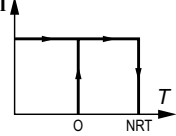
It must be emphasized that these sensors cannot be used to carry out direct adjustments to the motor operating cycles.

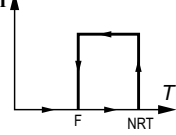
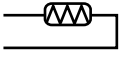
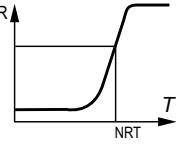
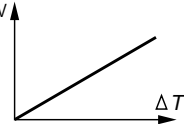
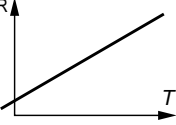
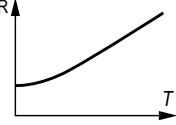
Type	Operating principle	Operating curve	Breaking capacity (A)	Protection provided	Mounting Number required*
Normally closed thermostat PTO	bimetallic strip, indirectly heated operates on opening (O) 		1.6 at 250 V with $\cos \varphi 0.6$	general surveillance for non-transient overloads	Mounted on control circuit 2 or 3 in series
Normally open thermostat PTF	bimetallic strip, indirectly heated, contact on closing (F) 		1.6 at 250 V with $\cos \varphi 0.6$	general surveillance for non-transient overloads	Mounted on control circuit 2 or 3 in parallel
Positive temperature coefficient thermistor PTC	Variable non-linear resistor, indirectly heated 		0	general surveillance for transient overloads	Mounted with associated relay on control circuit 3 in series
Thermocouples T ($T < 150^\circ\text{C}$) Constantan copper K ($T < 1000^\circ\text{C}$) Copper Copper-Nickel	Peltier effect		0	continuous surveillance at hot spots at regular intervals	Mounted on control panels with associated reading device (or recording device) 1 per hot spot
Platinum resistance thermometer PT 100	Variable linear resistance, indirectly heated		0	high accuracy continuous surveillance at key hot spots	Mounted on control panels with associated reading device (or recording device) 1 per hot spot
Resistance thermometer PT 1000	Resistance is depending on the winding temperature		0	high accuracy continuous surveillance at key hot spots	Mounted on control panels with associated reading device (or recording device) 1 per hot spot

- NRT: nominal running temperature.

- The NRTs are chosen according to the position of the sensor in the motor and the temperature rise class.

* The number of devices affects the protection of the windings.

Alarm and early warning

All protective equipment can be backed up by another type of protection (with different NRTs): The first device will then act as an early warning (light or sound signals given without shutting down the power circuits), and the second device will be the alarm (shutting down the power circuits).



Warning: Depending on the type of protection, the motor may remain powered-up. Ensure that the mains supply is disconnected before any work is carried out in the terminal box or in the cabinet.

Protection against condensation: space heaters

Identification: 1 label

A glass fibre flexible resistor is fixed on 1 or 2 coil end turns. This resistor heats the machines when stopped and thus prevents condensation inside the machines.

Power supply: 230V single-phase unless otherwise specified by the customer.



Warning: Check that the space heaters are powered down before any work is carried out in the terminal box or in the cabinet.

2.5 - Mains connection

2.5.1 - Terminal box

Placed as standard on the top of the motor near the drive end, for forms IM B3, B5, B14, the terminal box has IP 55 protection. Warning: The position of the terminal box cannot be easily modified, even with flanged motors, as the condensation drain holes must be at the bottom.

Cable gland

The standard position of the cable gland (1) is on the right, seen from the drive end.

If the non-standard position of the cable gland has not been correctly specified on the order, or is no longer suitable, the symmetrical construction of the terminal box enables it to be turned in any of the 4 directions except for position (2) on flange-mounted motors (B5).

A cable gland must never open upwards.

Check that the incoming cables have bends of such a radius as to prevent water from running into the cable gland.

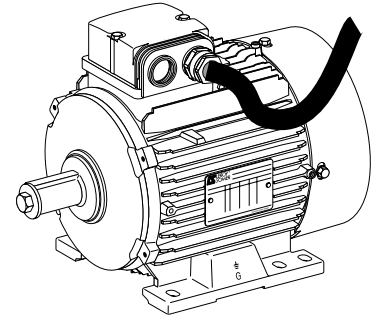
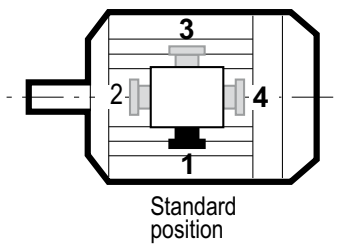
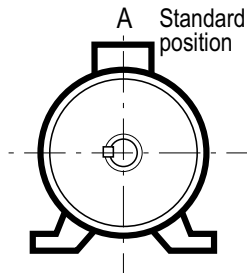

NB: motors are fitted with plugs or a support plate as standard.

Tightening capacity of cable glands



Adapt the cable gland and its reducer if present to the diameter of the cable being used. In order to preserve the motor's original IP55 protection, it is essential to tighten the cable gland seal correctly (so that it cannot be unscrewed by hand).

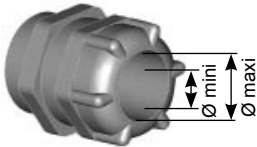

When there are several cable glands and some are not being used, ensure that they are always covered and tighten them so that they also cannot be unscrewed by hand.

2.5.2 - Cross-section of the power supply cables

The higher the current, the greater the voltage drop in the cables (standard NFC 15.100 or end user's national standard). The voltage drop should therefore be calculated **for the starting current** to see if this is suitable for the application.

If the most important criterion is the starting torque (or starting time), the voltage drop should be limited to 3% maximum (the equivalent of a loss of torque of around 6 to 8%).

The chart below can be used to select the conductors according to the length of the supply cables and the starting current, in order to limit the voltage drop to 3% maximum.

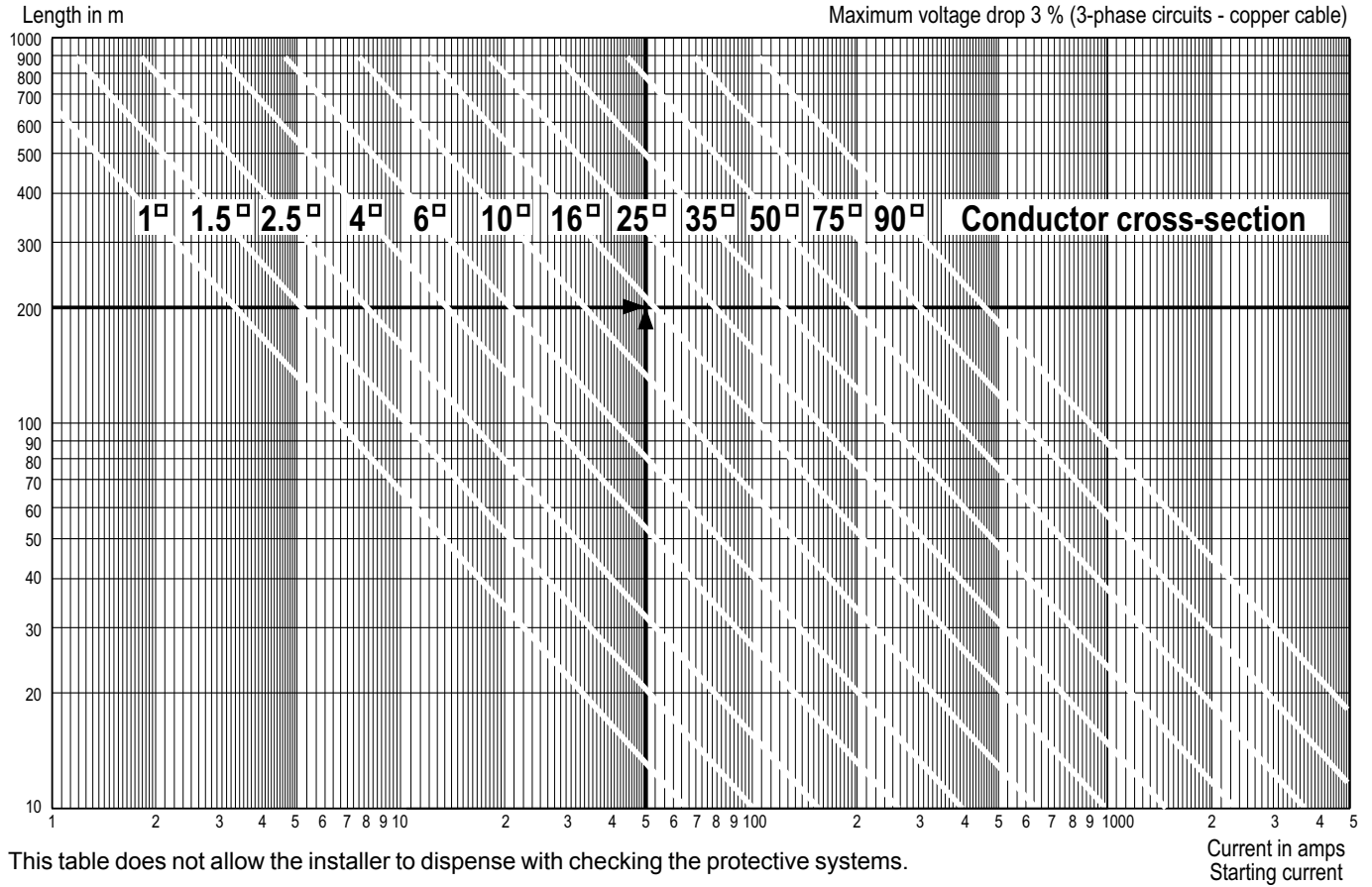

This table does not allow the installer to dispense with checking the protective systems.



For motors with flying leads, the power supply cable must not be used for handling.

2.5.3 - Connection of the motor-drive unit

When controlling an induction motor by means of a variable speed drive, certain rules must be adhered to in order to guarantee correct system performance.

For variable speed applications, follow the recommendations outlined in the Guide to best practices Motor-drive systems ref. 5626, and in the concerned drive manual too.

2.5.4 - Terminal block wiring diagram

All motors are supplied with a wiring diagram in the terminal box*.

The connector links required for coupling can be found inside the terminal box.

Single-speed motors are fitted with a block of 6 terminals complying with standard NFC 51 120, with the terminal markings complying with IEC 60034-8 (or NFC 51 118).



Particular attention must be paid to the information on the nameplate in order to choose the correct type of connection for the supply voltage.

2.5.5 - Direction of rotation

When the motor is powered by U1, V1, W1 or 1U, 1V, 1W from a direct mains supply L1, L2, L3, it turns clockwise when seen from the drive end.

If 2 phases of the power supply are changed over, the motor will run in an anti-clockwise direction (make sure the motor has been designed to run in both directions of rotation).

Warning: motor with backstop: starting in the wrong direction destroys the backstop (see arrow on motor housing).

If the motor is fitted with accessories (thermal protection or space heater), these should be connected on screw dominos or terminal blocks with labelled wires.

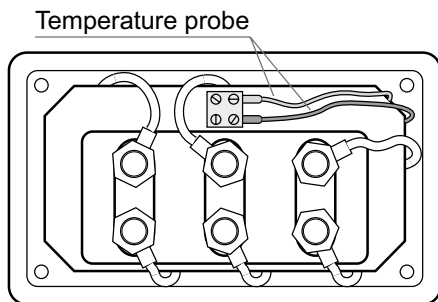

2.5.6 - Earth terminal

This is situated inside the terminal box; in some cases, the earth terminal may be situated on one of the feet or on one of the cooling fins (round motors).

It is indicated by the symbol: \perp



It is compulsory to earth the motor. Earthing must be performed in accordance with current regulations (protection of workers).

* If required, this diagram should be obtained from the supplier, specifying the motor type and number (shown on the motor nameplate).

2.5.7 - Connecting the power supply cables to the terminal block

The cables must be fitted with connectors suitable for the cable cross-section and the terminal diameter.

They must be crimped in accordance with the connector supplier's instructions.

Connection must be carried out with connector resting on connector (see the diagrams below):

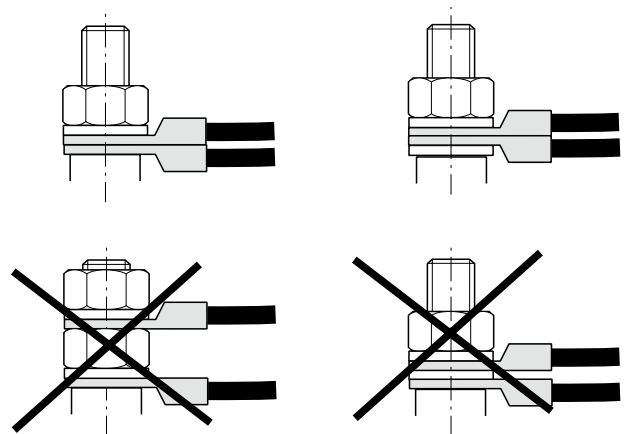

Tightening torque (N.m) on the terminal block nuts

Terminal	M4	M5	M6	M8	M10	M12	M14	M16
Steel	1	2.5	4	10	20	35	50	65
Brass	1	2	3	6	12	20	-	50

If using cables without connectors, attach some calipers. If any nuts on the brass terminal block are lost, they must be replaced by brass nuts, not steel ones.

When closing the box, ensure that the seal is correctly positioned.



As a general rule, check that no nut, washer or other foreign body has fallen into or come into contact with the winding.

3 - ROUTINE MAINTENANCE

Checks after start-up

After approximately 50 hours' operation, check that the screws fixing the motor and the coupling device are still tight. In the case of chain or belt transmission, check that the tension is correctly adjusted.

Cleaning

To ensure the motor operates correctly, remove any dust or foreign bodies which might clog the cover grille and the housing fins.

Precaution: before carrying out any cleaning operation check that the motor is completely sealed (terminal box, drain holes, etc).

Dry cleaning (vacuuming or compressed air) is always preferable to wet cleaning.



Always clean at reduced pressure from the center of the motor towards the extremities to avoid introducing dust and particles under the seals.

Draining off condensation water

Temperature variations cause condensation to form inside the motor, which must be removed before it adversely affects motor operation.

Condensation drain holes, located at the bottom of the motors (bearing in mind their operating position) are sealed with plugs which must be removed and then replaced every six months (if they were not replaced, the motor degree of protection would no longer be maintained). Clean the orifices and plugs before reassembling them.

Note: In conditions of high humidity and significant temperature variations, a shorter period is recommended.

As long as it poses no risk to the motor protection, the condensation drain plugs can be removed.

3.1 - Greasing

3.1.1 - Type of grease

When the bearings are not greased for life, the type of grease is indicated on the nameplate.

As standard this grease is Polyrex EM103 and we recommend that it is used for subsequent lubrication.

Avoid mixing greases.

3.1.2 - Permanently greased bearings

For **LS/LSES, FLS/FLSES and CILS ≤ 225 motors**, the bearings defined offer long grease life and therefore lubrication for the lifetime of the machines. The grease life according to speed of rotation and ambient temperature is shown in the technical catalogue ref.5147 (www.leroy-somer.com).

3.1.3 - Bearings with grease nipples

The bearings are lubricated in the factory

The end shields are fitted with bearings lubricated by grease nipples such as M8 x 125. Greasing intervals are available in the technical catalogue ref.5147 (www.leroy-somer.com).



The frequency of lubrication and the quantity and quality of grease are given on the nameplates and these should be referred to in order to ensure correct bearing lubrication.



Even in the event of prolonged storage or downtime, the interval between 2 greasing operations should never exceed 2 years.

3.2 - Bearing maintenance

3.2.1 - Checking the bearings

As soon as you detect any of the following on the motor:

- Abnormal noise or vibration
 - Abnormal temperature rise in the bearing even though it has been lubricated correctly,
- the condition of the bearings must be checked.

Damaged bearings must be replaced as soon as possible to prevent worse damage to the motor and the equipment being driven.

If one bearing needs to be replaced, **the other bearing must also be replaced.**

The seals should be changed routinely when the bearings are changed.

The free bearing must allow the rotor shaft to expand (check its identification during dismantling).

3.2.2 - Reconditioning the bearings

Bearings without grease nipples

Dismantle the motor (see section 6.1); remove the old grease and clean the bearings and accessories with degreasing agent.

Fill with new grease: the correct amount of new grease for the bearing is 50% of the free space.

Bearings with grease nipples

Always begin by cleaning the waste grease channel

If using the type of grease stated on the nameplate, remove the covers and clean the grease nipple heads.

If a different grease from that on the nameplate is being used, the motor must be dismantled and the bearings and accessories cleaned with degreasing agent (carefully clean the grease inlet and outlet pipes) to remove the old grease before relubrication. To ensure correct lubrication, fill the inner free spaces of the bearing retainers, flanges and grease pipes and 30% of the bearing free space.

Then rotate the motor shaft to distribute the grease.

Warning:

Too much grease causes the bearing to overheat (statistics show that more bearings are damaged through too much grease than too little grease).

Important note:

The new grease should be recently manufactured, of equivalent performance and should not contain any impurities (dust, water, etc).

4 - PREVENTIVE MAINTENANCE

Please consult NIDEC LEROY-SOMER who, in its continuous search for ways to help customers, has evaluated numerous methods of preventive maintenance.

The diagram and table below give the recommended equipment to use and the ideal positions to take measurements of all parameters which can affect the operation of the machine, such as eccentricity, vibration, state of bearings, structural problems, electrical problems, etc.

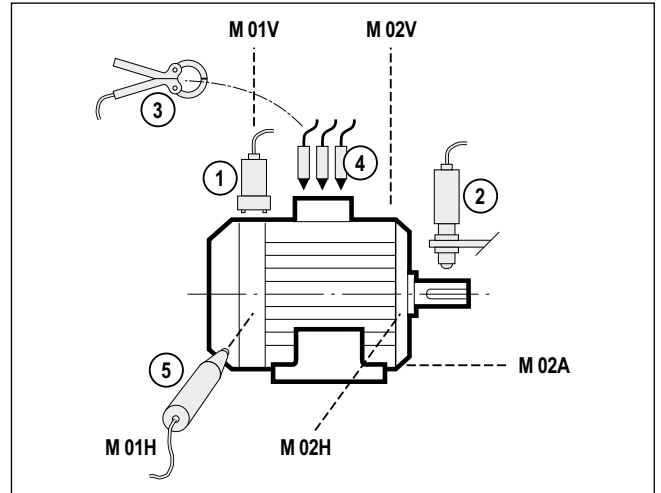

Detector	Measurement	Measurement points								
		M 01V	M 01H	M 02V	M 02H	M 02A	Shaft	E01	E02	E03
① Accelerometer	For measuring vibrations	●	●	●	●	●				
② Photo-electric cell	For measuring speed and phase (balancing)						●			
③ Clamp ammeter	For measuring current (D.C. and 3-phase)							●	●	●
④ Voltage probe	For measuring voltage							●	●	●
⑤ Infra-red probe	For measuring temperature	●		●						

5 - TROUBLESHOOTING GUIDE

Incident	Possible cause	Remedy
Abnormal noise	Originating in motor or machine being driven?	Uncouple the motor from the equipment being driven and test the motor on its own
Noisy motor	The cause is mechanical if the noise persists after switching off the power supply, with the drive set to «freewheel» mode	
	- vibration	- check that the key conforms to the type of balancing (see section 2.3)
	- damaged bearings	- change the bearings
	- mechanical friction: ventilation, coupling	- check and replace the defective part
	The cause is electrical if the noise stops after switching off the power supply	- check the power supply at the motor terminals - check the drive settings
	- normal voltage and 3 phases balanced	- check the connection of the terminal block and the tightening of the terminals
	- abnormal voltage	- check the power supply line
	- phase imbalance	- check the winding resistance
	Other possible causes: - incorrect settings - drive malfunction	- refer to the drive manual
	Motor heats abnormally	- faulty ventilation
- faulty supply voltage		- check
- terminal connection fault		- check
- overload		- check the current consumption in relation to that indicated on the motor nameplate
- partial short-circuit		- check the electrical continuity of the windings and/or the installation
- phase imbalance		- check the winding resistance
Other possible causes: - incorrect settings - drive malfunction		- refer to the drive manual
Motor does not start		at no load - mechanical locking
	- broken power supply line	- check the fuses, electrical protection, starting device
	- position feedback (drive message)	- check the drive wiring and settings, operation of the position sensor
	- thermal protection	- check
	on load - phase imbalance	When switched off: - check the direction of rotation (phase order) - check the resistance and continuity of the windings - check the electrical protection
	- drive	- check the settings and sizing (max. current that can be delivered by the drive)
	- position feedback (drive message)	- check the drive wiring and settings, operation of the position sensor
	- thermal protection	- check

6 - CORRECTIVE MAINTENANCE: GENERAL



First switch off and lock the power supply

- Open the terminal box, mark the wires and their positions
 - Disconnect the power supply wires
 - Uncouple the motor from the equipment being driven
- Always use an extractor to remove any devices mounted on the shaft end of the motor.

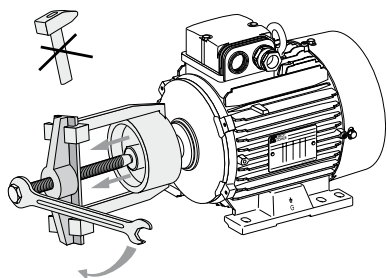

6.1 - Dismantling the motor

Refer to the detailed instructions for the relevant motor range (see following pages). It is advisable to mark the shields in relation to the stator and the direction in which the rotor fan is mounted.

6.2 - Checks before reassembly

Stator:

- Remove all dust from the stator:
- If the winding needs to be cleaned, a suitable liquid must be used: dielectric and inert on the insulating components and the external finish.
- Check the insulation (see section 2.1) and if necessary, dry it in an oven.
 - Clean the spigots thoroughly, and remove all traces of knocks on the mating surfaces if necessary.

Rotor:

- Clean and check the bearing running surfaces. If they are damaged, renew the running surfaces or change the rotor.
- Check the condition of the threads, keys and their housings.

End shields:

- Clean off any traces of dirt (old grease, accumulated dust, etc).
- Clean the bearing housings and the spigot.
- If necessary, apply anti-flash varnish to the insides of the end shields.
- Carefully clean the bearing retainers and the grease valves (if these are fitted on the motor).

6.3 - Mounting the bearings on the shaft

This operation is extremely important, as the slightest indentation of a ball on the bearing tracks would cause noise and vibration.

Lightly lubricate the running surfaces of the shaft.

There are a number of ways of mounting the bearings correctly:

- Cold state: The bearings must be mounted without any impact, using a spanner (do not use a hammer). The force applied must not be transferred to the bearing track. You should therefore use the internal cage for support (taking care not to press on the seal shield for sealed bearings).

- Hot state: Heat the bearing to between 80 and 100 °C: in a dryer, an oven or on a heating plate. (A blowtorch or an oil bath must never be used).

After dismantling and reassembling a bearing, all the spaces between the seals and labyrinth seals must be filled with grease in order to prevent the entry of dust and the rusting of machined parts.

See detailed instructions for the relevant motor ranges in the following pages.

6.4 - Reassembling the motor

Be careful to replace the stator in its original position, that the stack of laminations is centered correctly (generally with the terminal box facing forward) and the water drain holes are positioned correctly if they are on the housing.

Tightening the tie rods/screws

These must be tightened diagonally, to the torque indicated (see below).

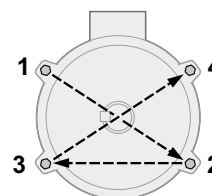

Tie rods/screws tightening torque

Type	Rod/screw Ø	Tightening torque N. m ± 5%
56	M4	2.5
63	M4	2.5
71	M4	2.5
80	M5	4
90	M5	4
100	M5 or M6	4
112	M5 or M6	4
132	M7	10
160	M8	18
180 MT/LR/LUR	M8	18
180 L	M10	25
200	M10	25
225 ST/MR/SR	M10	25
225 MK	M12	44
250	M12	44
280	M12	44
315	M12	44
315 LK / 355	M16	100
355 LK / 400	M16	100
450	M16	100

6.5 - Reassembling the terminal box

Reconnect all the power supply wires in accordance with the diagram or markings made before dismantling.

To ensure the box is properly sealed: check that the cable glands on the box and the cable(s) have been retightened, and ensure that the seal has been correctly positioned before closing. For terminal boxes equipped with a horn or/and a cable gland support plate, ensure that the seal has been correctly positioned before closing. Check that the terminal box components are tightened correctly.

Note: It is advisable to test the motor at no load

- If necessary, repaint the motor.
- Mount the transmission device on the motor shaft extension and reinstall the motor on the machine to be driven.

7 - POSITION OF LIFTING RINGS



Position of lifting rings for lifting the motor only (not connected to the machine).

Labour regulations stipulate that all loads over 25 kg must be fitted with lifting devices to facilitate handling.

The positions of the lifting rings and the minimum dimensions of the loading bars are given below in order to help with preparation for handling the motors. If these precautions are not followed, there is a risk of warping or crushing some equipment such as the terminal box, protective cover or drip cover.



Motors intended for use in the vertical position may be delivered on a pallet in the horizontal position. When the motor is pivoted, the shaft must under no circumstances be allowed to touch the ground, as the bearings may be irreparably damaged. Moreover, additional special precautions must be taken, as the integral motor lifting rings are not designed for pivoting the motor.

• Horizontal position

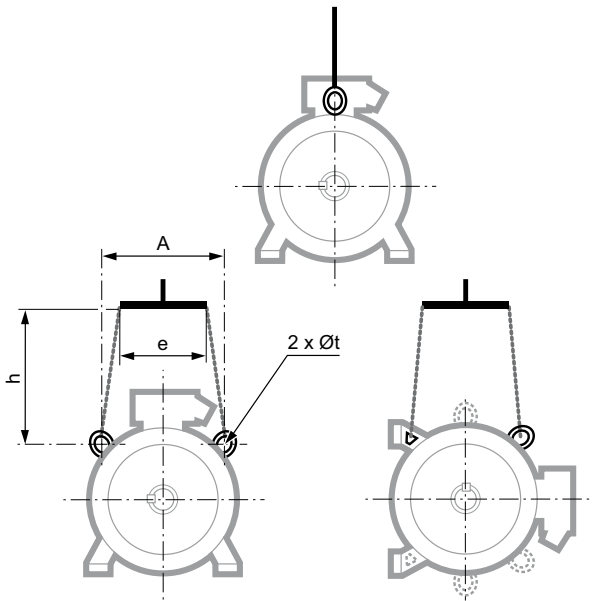

Type	Horizontal position			
	A	e min	h min	Øt
LSES 100 L/LR/LG	165	165	150	9
LSES 112 M/MR	165	165	150	9
LSES 112 MG/MU	-	-	-	9
LSES 132 S/SU	180	180	150	9
LSES 132 M/MU	200	180	150	14
LSES 160 MP/MR/LR	200	180	110	14
LSES 160 M/MU/L/LUR	200	260	150	14
LSES 180 M/MUR/L/LUR	200	260	150	14
LSES 200 L/LR	270	260	150	14
LSES 200 LU	270	260	150	14
LSES 225 SR/MR	270	260	150	14
LSES 225 S/SG/M/MG	360	380	200	30
LSES 250 MZ	360	380	200	30
LSES 250 ME	400	400	500	30
LSES 280 SC/SD/MC/MD	400	400	500	30
LSES 315 SN	400	400	500	30
LSES 315 SP/MP/MR	360	380	500	17

Type	Horizontal position			
	A	e min	h min	Øt
FLSES 100	152	200	150	22
FLSES 100 LG	145	200	150	22
FLSES 112	145	200	150	22
FLSES 132	180	200	150	25
FLSES 160 M/MU	200	260	150	14
FLSES 180 M/MUR/L/LUR	200	260	150	14
FLSES 200 LU	270	260	150	14
FLSES 225 SR/MR	270	260	150	14
FLSES 225 S/M	360	380	200	30
FLSES 250 M/MR	360	380	200	30
FLSES 280	360	380	500	30
FLSES 315 S/M/LA/LB	440	400	500	60
FLSES 355	545	500	500	60
FLSES 355 LK	685	710	500	30
FLSES 400	735	710	500	30
FLSES 450	730	710	500	30

Type	Horizontal position			
	A	e min	h min	Øt
CILS 225 S/M	360	380	300	30
CILS 250 M	360	600	300	30
CILS 280 MG/SG	455	400	400	30
CILS 315 SE/ME/LE	455	400	400	30

Type	Horizontal position			
	A	e min	h min	Øt
PLSES 225 MG	310	300	300	30
PLSES 250 MF/SF	310	300	300	30
PLSES 280 MD/MGU/SGU	310	300	300	30
PLSES 315 SUR/MUR/L/LD/LUS	385	380	500	30
PLSES 315 LG/MGU/VLG/VLGU	450	750	550	48

• Vertical position

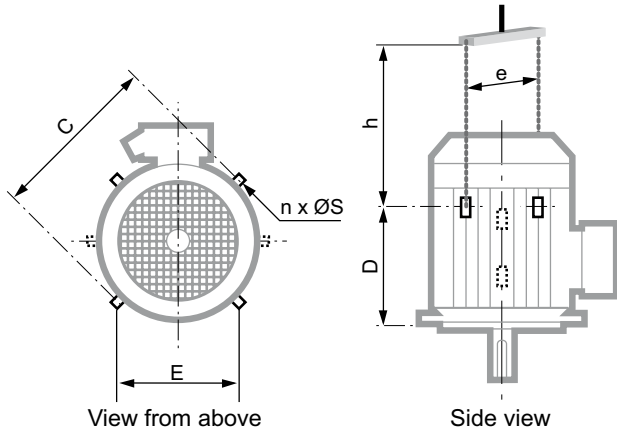

Type	Vertical position						
	C	E	D	n**	ØS	e min*	h min
LSES 160 M/MU/L/LUR	320	200	230	2	14	320	350
LSES 180 MR	320	200	230	2	14	320	270
LSES 180 M/L/LUR	390	265	290	2	14	390	320
LSES 200 L/LR/LU	410	300	295	2	14	410	450
LSES 225 SR/MR	480	360	405	4	30	540	350
LSES 225 S/SG/M/MG	480	360	405	4	30	500	500
LSES 250 MZ	480	360	405	4	30	590	550
LSES 250 ME	480	360	405	4	30	500	500
LSES 280 SC/SD/MC/MD	480	360	405	4	30	500	500
LSES 315 SN	480	360	405	4	30	500	500
LSES 315 SP/MP/MR	630	700	570	2	30	630	550

Type	Vertical position						
	C	E	D	n**	ØS	e min*	h min
FLSES 160 M/MU	320	200	230	2	14	320	350
FLSES 180 M/MUR/L/LUR*	320	200	230	2	14	320	270
FLSES 200 LU	410	300	295	2	14	410	450
FLSES 225 SR/MR	410	300	295	2	14	410	450
FLSES 225 S/M	480	360	405	4	30	540	350
FLSES 250 M/MR	480	360	405	4	30	590	550
FLSES 280 S/M	480	360	585	4	30	590	550
FLSES 315 S/M/LA/LB	620	350	715	2	35	650	550
FLSES 355	760	350	750	2	35	800	550
FLSES 355 LK	810	350	1135	4	30	810	600
FLSES 400	810	350	1135	4	30	810	600
FLSES 450	960	400	1170	4	30	960	750

Type	Vertical position						
	C	E	D	n**	ØS	e min*	h min
CILS 225 S/M	480	360	520	4	30	480	250
CILS 250 M	480	330	520	4	30	480	400
CILS 280 SG/MG	640	455	600	4	30	640	400
CILS 315 SE/ME/LE	640	455	780	4	35	640	400

Type	Vertical position						
	C	E	n**	ØS	e min*	h min	
PLSES 225 MG	450	310	2	14	450	490	
PLSES 250 SP/MP/MF	450	310	4	30	450	490	
PLSES 280 SD/MD/MG	450	310	4	30	450	490	
PLSES 315 M/MUR/L/LD/LDS/LU/S/SUR	500	385	4	30	500	500	
PLSES 315 LG/MGU/VLGV/LGU	750	450	4	48	750	450	

* If the motor is fitted with a drip cover, allow an additional 50 to 100 mm to avoid damaging it when the load is swung.

** If n = 2, the lifting rings form an angle of 90° with respect to the terminal box axis. If n = 4, this angle becomes 45°.

8 - SPARE PARTS

When ordering spare parts, you must indicate the complete motor type, its serial number and the information given on the nameplate (see section 1).

Part numbers can be found on the exploded views and their descriptions in the parts list (section 6).

In the case of flange mounted motors, indicate the type of flange and its dimensions (see below).

IM 3001 (IM B5)

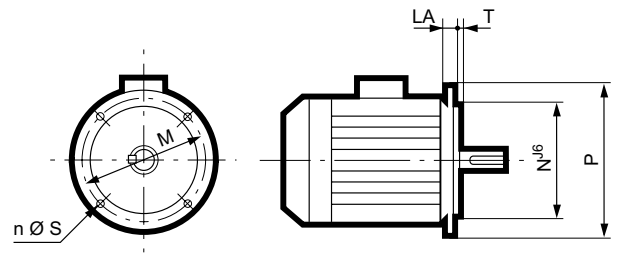

IM 3601 (IM B14)

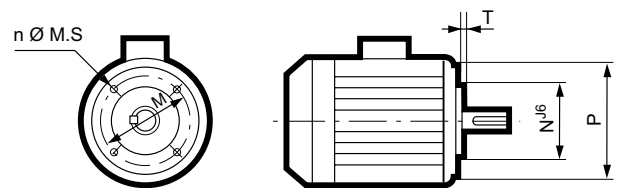

Our extensive network of service centers can dispatch the necessary parts without delay.

To ensure that our motors operate correctly and safely, we recommend the use of original manufacturer spare parts.

In the event of failure to comply with this advice, the manufacturer cannot be held responsible for any damage.

9 - RECYCLING

At the end of life, we advise that you contact a salvage company to recycle the various motor components.

DISMANTLING AND REASSEMBLY PROCEDURES

10 - LS/LSES motors24 to 33

11 - FLS/FLSES motors34 to 43

12 - CILS motors44 to 49

13 - PLSES motors50 to 55

10 - LS/LSES MOTORS

10.1 - LS/LSES 71 to 160 MP/LR motors

10.1.1 - Dismantling

- Remove the screws (27) in the case of a metal cover and then take off the cover (13).
- Pull out the fan (7) using a hub remover or 2 levers (for example, 2 screwdrivers) diametrically opposed to one another, using the shield (6) for support.
- Remove the tie rods (14).
- Remove the key (21).
- Using a wooden mallet, tap the shaft on the fan side in order to loosen the drive end shield (5).
- Remove the rotor shaft (3) and the DE shield (5) taking care not to knock the winding.
- Remove the shield on the fan side (6).
- Take out the preloading washer (59) and the seal of the NDE shield (54) for LS/LSES 100, 112 and 132 motors.
- Remove the circlip (60) from flanged motors using angled circlip pliers.
- Separate the DE shield from the rotor shaft.
- The shaft can then be seen with its 2 bearings and, if appropriate, the circlip.
- Use a bearing remover to take out the bearings, taking care not to knock the running surfaces of the shaft.

10.1.2 - Reassembling motors without circlip

- Mount the bearings on the rotor shaft.
- Insert the rotor into the stator taking all possible precautions not to knock the winding.
- Mount the DE shield (5).
- For LS/LSES 71 motors, mount the seal (39) with grease beforehand.
- Place the preloading washer (59) in the bearing housing, then mount the NDE shield (6).
- Place the tie rods (14) in position and tighten the nuts diagonally up to the recommended torque (see section 6.4).
- Mount the shield seals (39, 54, 308) with grease.
- Mount the fan (7) using a drift to bed it into position.
- Check that the motor turns freely by hand and that there is no radial play.
- Replace the cover (13) and fix it with the screws (27).

10.1.3 - Reassembling motors with flange and circlip

- Mount the DE bearing (30) in the flange (5) using the outer slip-ring for support.
- Fit the circlip (60).
- Mount this assembly on the rotor (3) using the inner slip-ring for support.
- Mount the NDE bearing on the rotor.
- Insert the rotor (3) and shield (5) assembly in the stator taking care not to knock the winding.
- Place the preloading washer (59) in the bearing housing, then mount the NDE shield (6).
- Place the tie rods (14) in position and tighten the nuts diagonally up to the recommended torque (see section 6.4).
- Mount the shield seals (39, 54, 308) with grease.
- Mount the fan (7) using a drift to bed it into position.
- Check that the motor turns freely by hand and that there is no axial play.
- Replace the cover (13) and fix it with the screws (27).
- Replace the key (21).

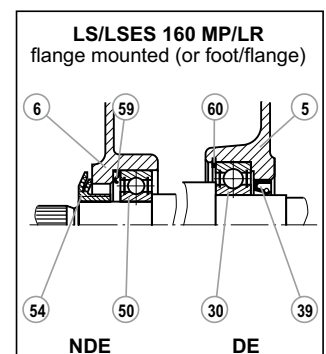
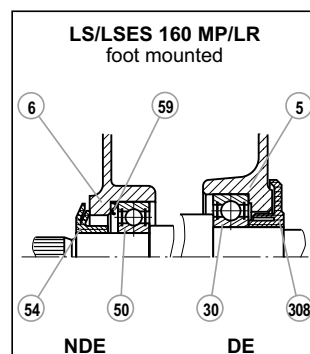
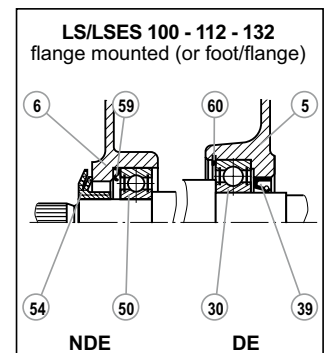
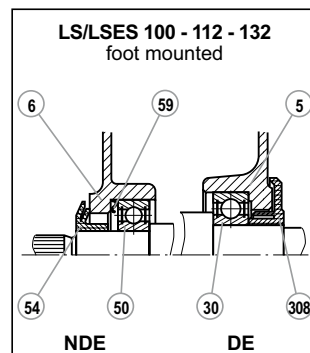
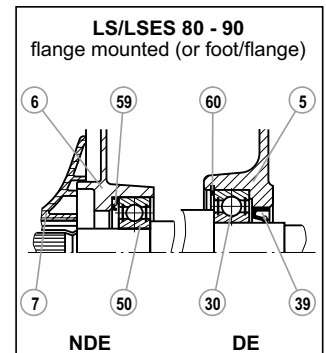
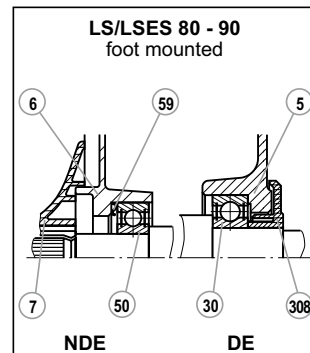
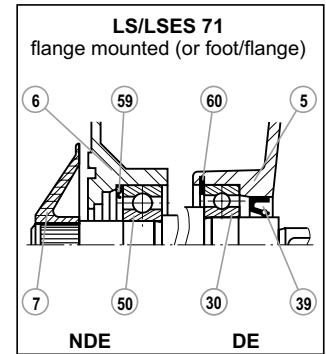
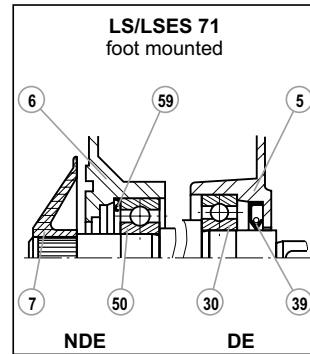

LS/LSES 71 to 160 MP/LR

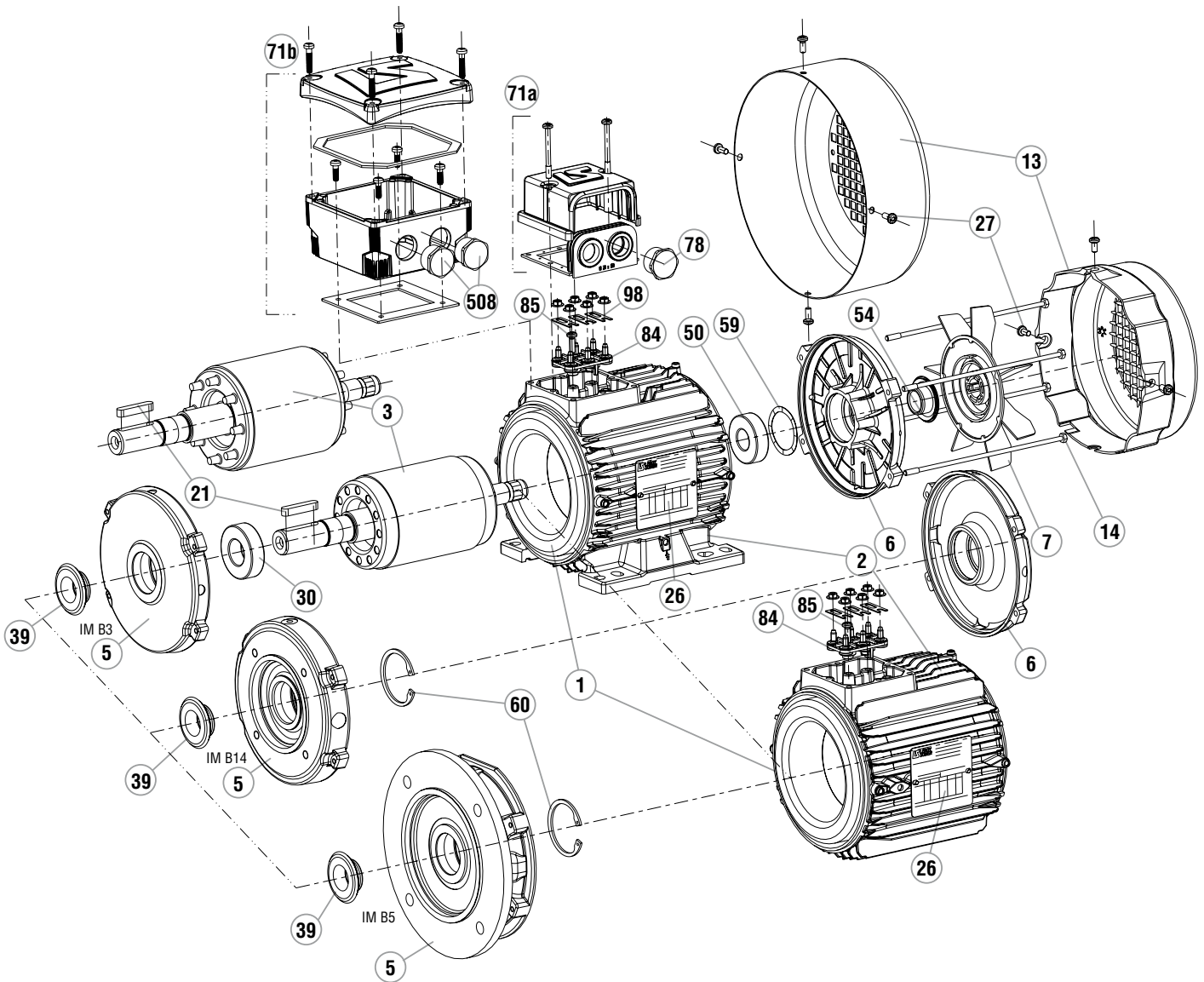

LS/LSES 71 to 160 MP/LR

Ref.	Description	Ref.	Description	Ref.	Description
1	Wound stator	21	Drive end shield shaft extension key	60	Circlip
2	Frame	26	Nameplate	71 a	Plastic terminal box (< or = frame size 112)
3	Rotor	27	Fan cover screw	71 b	Metal terminal box
5	Drive end shield	30	Drive end bearing	84	Terminal block
6	Non drive end shield	39	Drive end seal	85	Set screw
7	Fan	50	Non drive end bearing	98	Connectors
13	Fan cover	54	NDE weatherproof seal	508	Terminal box plug
14	Tie rods	59	Preloading (wavy) washer		

10.2 - LS/LSES 160 M/L/LU, 180 MT/LR motors

10.2.1 - Dismantling

- Remove the screws (27) and then take off the cover (13).
- Pull out the fan (7) using a hub remover or 2 levers diametrically opposed to one another, using the shield (6) for support.
- Take out the key (21) and remove the seals (39 and 54 for foot mounted motors) (54 for flange mounted motors).
- Remove the mounting screws (14).
- Unscrew the inner bearing retainer (33) fixing screws (40) when using a flange mounted motor or if the drive end bearing is locked.
- Using a bronze drift, remove the shields (5 and 6) by tapping gently on the shield bosses. Recover the preloading washer (59).
- Remove the circlip (38) if necessary (flange mounted motor).
- Remove the rotor (3) from the stator (1) taking care not to touch the winding.
- Take out the bearings (30) and (50) using a bearing remover, while protecting the end of the shaft extension with a washer. Avoid knocking the running surfaces of the shaft.

10.2.2 - Reassembly

- See section 6.1 before reassembly.
- If necessary, insert the inner bearing retainer (33) at the rotor drive end, then mount new bearings on the shaft, see section 6.3 mounting bearings.
- Mount the circlip (38) for flange mounted motors.
- Insert the rotor (3) in the stator (1) taking care not to knock the winding.
- Position the preloading washer (59) with a small amount of grease in the back of the bearing cage of the NDE shield (6), then remount the NDE shield (6), positioning it on the stator.
- If there is a bearing retainer (33), screw a rod with the same thread diameter as the screws (40) into one of the tapped holes of the bearing retainer to maintain its angular position when remounting the DE shield (5).
- Remount the shield (5) taking care to allow for the positioning of a bearing retainer if used.
- Place the mounting screws (14) in position and tighten the nuts diagonally up to the recommended torque (see section 6.1).
- If necessary, fix the bearing retainer (33) with its own screws.
- Mount the shield seals with grease: (54 at the non drive end) (39 at the drive end for foot mounted motors).
- Mount the fan (7) using a drift to bed it into position.
- Check that the rotor turns freely by hand (that there is no axial play if there is a locked end shield).
- Replace the cover (13) and fix it with the screws (27).
- Replace the key (21).

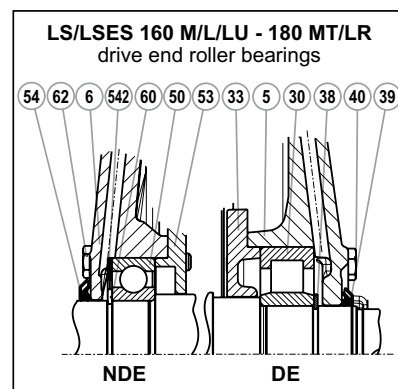
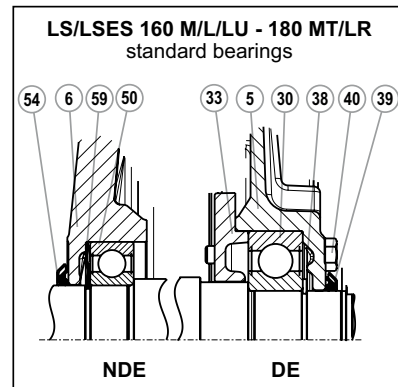

LS/LSES 160 M/L/LU, 180 MT/LR

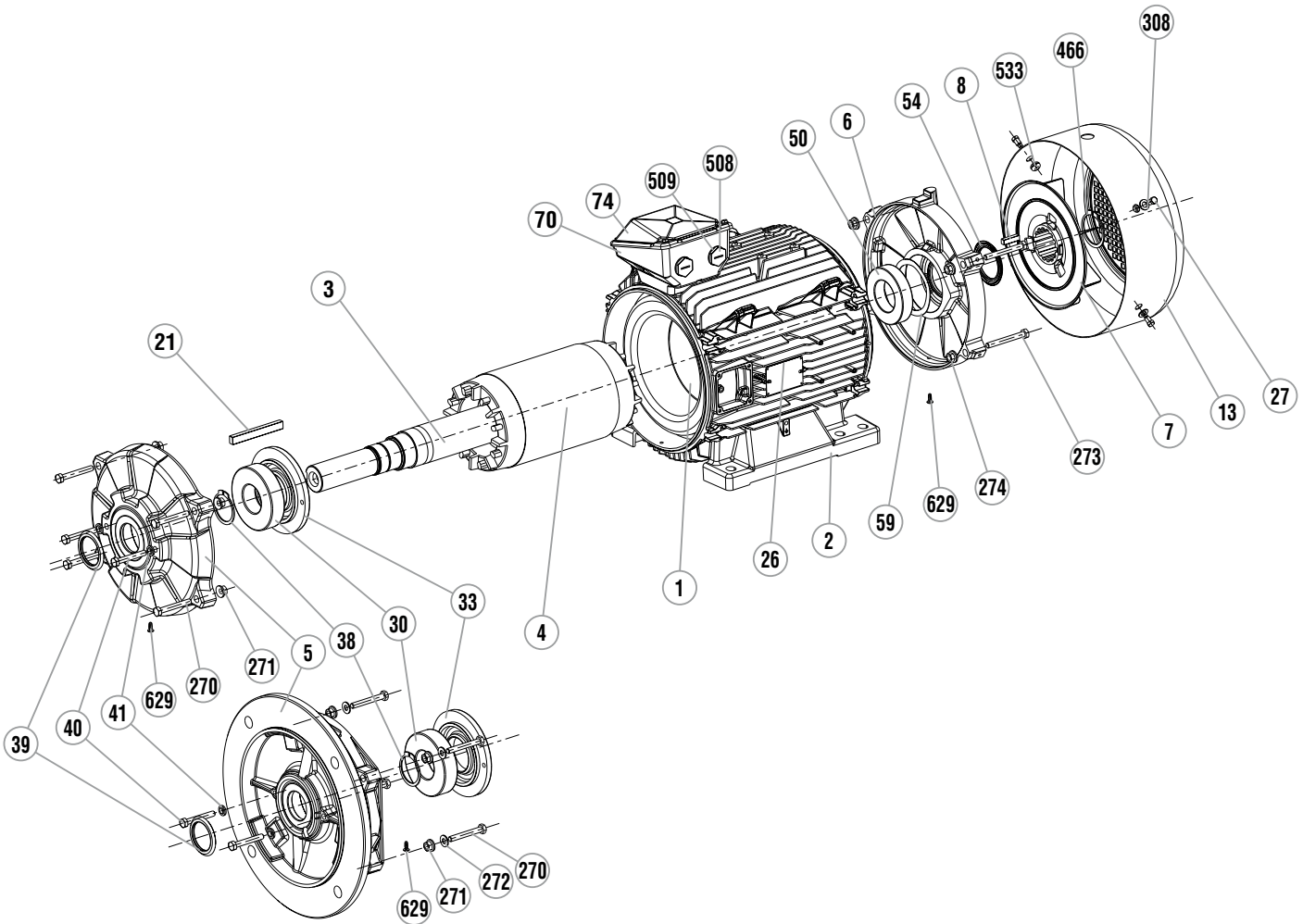

LS/LSES 160 M/L/LU, 180 MT/LR

Ref.	Description	Ref.	Description	Ref.	Description
1	Wound stator	30	Drive end bearing	271	Drive end shield fixing nut
2	Frame	33	Inner drive end bearing retainer	272	DE shield washer
3	Shaft	38	Snap ring for drive end shaft	273	Non drive end shield fixing screw
4	Rotor	39	Drive end seal	274	NDE shield fixing nut
5	Drive end shield	40	Drive end cover fixing screw	308	Cover fixing washer
6	Non drive end shield	41	Leaktight toothed lock washer for DE bearing retainer	466	Snap ring for fan
7	Fan	50	Non drive end bearing	508	Terminal box plug
8	Fan key	54	NDE weatherproof seal	509	Cable gland seal
13	Fan cover	59	Preloading (wavy) washer	533	Cover shock mount
21	Drive end shield shaft extension key	70	Terminal box	629	Draining plug
26	Nameplate	74	Terminal box lid		
27	Fan cover screw	270	Drive end shield fixing screw		

10.3 - LS/LSES 180 L/LUR, 200 L/LR/LU, 225 ST/MT/MR, 250 MZ motors

10.3.1 - Dismantling

- Remove the screws (27) and then take off the cover (13).
- Pull out the fan (7) using a hub remover or 2 levers diametrically opposed to one another, using the shield (6) for support.
- Take out the key (21) and remove the seals (39 and 54 for foot mounted motors) (54 for flange mounted motors).
- Remove the mounting screws (270 + 273).
- Unscrew the inner bearing retainer (33) fixing screws (40) when using a flange mounted motor or if the drive end bearing is locked.
- Using a bronze drift, remove the shields (5 and 6) by tapping gently on the shield bosses. Recover the preloading washer (59).
- Remove the circlip (38) if appropriate.
- Remove the rotor (3) from the stator (1) taking care not to touch the winding.
- Take out the bearings (30) and (50) using a bearing remover, while protecting the end of the shaft extension with a washer. Avoid knocking the running surfaces of the shaft.

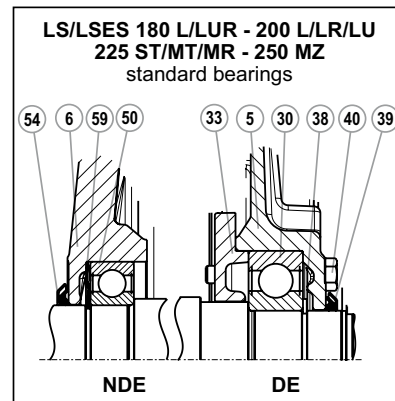

10.3.2 - Reassembly

- See section 6.1 before reassembly.
- If necessary, insert the inner bearing retainer (33) at the rotor drive end, then mount new bearings on the shaft, see section 6.3 mounting bearings.
- Fill with new grease: the correct amount of new grease for the bearing is 50% of the free space.
- Mount the circlip (38) if necessary.
- Insert the rotor (3) in the stator (1) taking care not to knock the winding.
- Position the preloading washer (59) with a small amount of grease in the back of the bearing cage of the NDE shield (6), then remount the NDE shield (6), positioning it on the stator.
- If there is a bearing retainer (33), screw a rod with the same thread diameter as the screws (40) into one of the tapped holes of the bearing retainer to maintain its angular position when remounting the DE shield (5).
- Remount the shield (5) taking care to allow for the positioning of a bearing retainer if used.
- Place the mounting screws (14) in position and tighten the nuts diagonally up to the recommended torque (see section 6.1).
- If necessary, fix the bearing retainer (33) with the screws (40).
- Mount the shield seals with grease: (54 at the non drive end) (39 at the drive end for foot mounted motors).
- Mount the fan (7) using a drift to bed it into position.
- Check that the rotor turns freely by hand (that there is no axial play if there is a locked end shield).
- Replace the cover (13) and fix it with the screws (27).
- Replace the key (21).

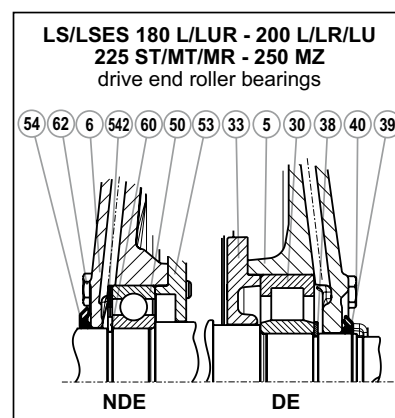

LS/LSES 180 L/LUR, 200 L/LR/LU, 225 ST/MT/MR, 250 MZ

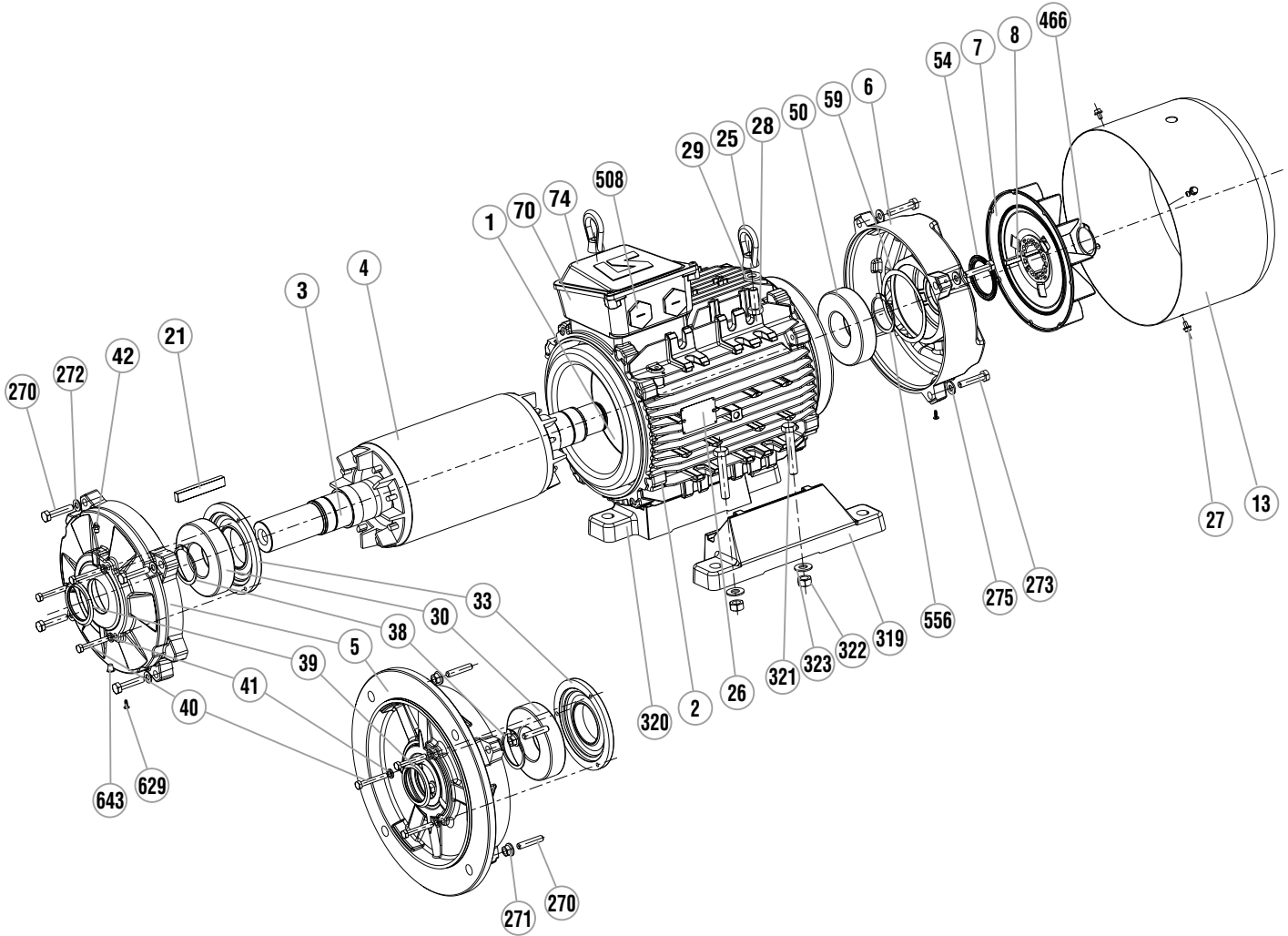

LS/LSES 180 L/LUR, 200 L/LR/LU, 225 ST/MT/MR, 250 MZ

Ref.	Description	Ref.	Description	Ref.	Description
1	Wound stator	29	Lifting ring fixing washer	271	Drive end shield fixing nut
2	Frame	30	Drive end bearing	272	DE shield washer
3	Shaft	33	Inner drive end bearing retainer	273	Non drive end shield fixing screw
4	Rotor	38	Snap ring for drive end shaft	275	Fixing washer for NDE shield
5	Drive end shield	39	Drive end seal	319	Right foot
6	Non drive end shield	40	Drive end cover fixing screw	320	Left foot
7	Fan	41	Leaktight toothed lock washer for DE bearing retainer	321	Screws for feet
8	Fan key	42	Drive end grease nipples	322	Nut for feet
13	Fan cover	50	Non drive end bearing	323	Washer for feet
21	Drive end shield shaft extension key	54	NDE weatherproof seal	466	Snap ring for fan
25	Lifting ring	59	Preloading (wavy) washer	508	Terminal box plug
26	Nameplate	70	Terminal box	556	NDE bearing circlip
27	Fan cover screw	74	Terminal box lid	629	Draining plug
28	Lifting ring fixing screw	270	Drive end shield fixing screw	643	DE grease draining plug

LS/LSES 225 MG, 250 ME/MF, 280 SC/MC/SD/MD, 315 SN

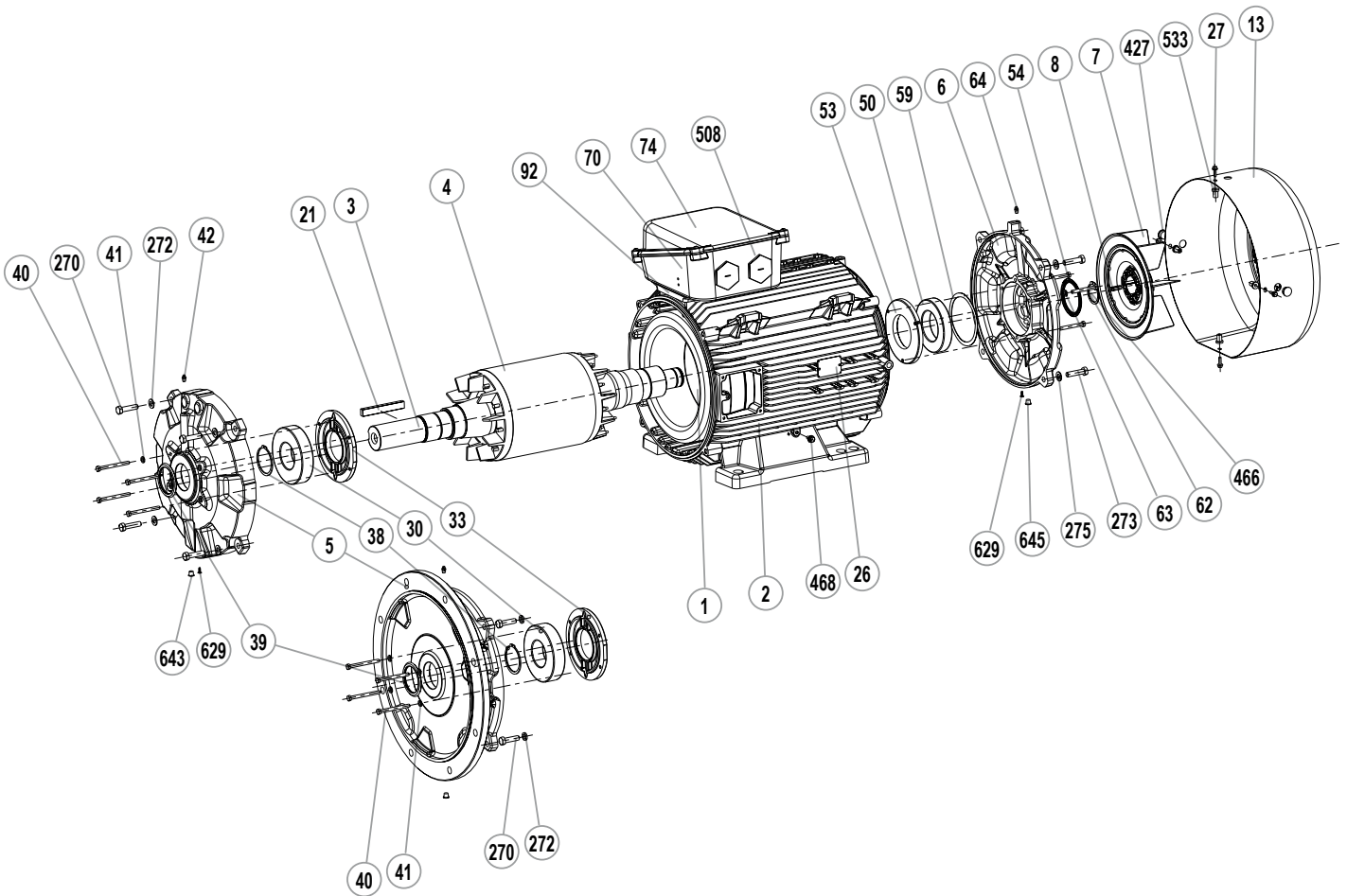

LS/LSES 225 MG, 250 ME/MF, 280 SC/MC/SD/MD, 315 SN

Ref.	Description	Ref.	Description	Ref.	Description
1	Wound stator	38	Snap ring for drive end shaft	92	Terminal box baseplate
2	Frame	39	Drive end seal	270	Drive end shield fixing screw
3	Shaft	40	Drive end cover fixing screw	272	DE shield washer
4	Rotor	41	Leaktight toothed lock washer for DE bearing retainer	273	Non drive end shield fixing screw
5	Drive end shield	42	Drive end grease nipples	275	Fixing washer for NDE shield
6	Non drive end shield	50	Non drive end bearing	427	Cover plug
7	Fan	53	Inner non drive end bearing retainer	466	Snap ring for fan
8	Fan key	54	NDE weatherproof seal	468	Earth terminal plug
13	Fan cover	59	Preloading (wavy) washer	508	Terminal box plug
21	Drive end shield shaft extension key	62	Cover fixing screw	533	Cover shock mount
26	Nameplate	63	Fixing washer for NDE bearing retainer	629	Draining plug
27	Fan cover screw	64	Non drive end grease nipple	643	DE grease draining plug
30	Drive end bearing	70	Terminal box	645	NDE grease draining plug
33	Inner drive end bearing retainer	74	Terminal box lid		

10.5 - LS/LSES 280 SU/SK/MK, 315 (except SN) motors

10.5.1 - Dismantling

- Remove the screws (27), the grease nipple (42) and its extension, then take off the cover (13).
- Pull out the fan (7) using a hub remover or 2 diametrically opposed levers, using the shield (6) for support; for an aluminium fan, heat the hub to approximately 100°C before removing it.
- Take out the key (21).
- Unscrew the tie rods (14) then remove them.
- Unscrew the DE bearing retainer (33) fixing screws (40) and NDE bearing retainer (32) and (52) fixing screws (62), and remove the bearing retainers.
- Unscrew the «CHc» screws of the mobile valves (35 and 56) then unscrew the valves using a hook spanner or a conical bronze drift; unscrew the valves by hand and remove them. The valves hold the seal (39 and 54).
- Remove the fixed valves (34 and 35) from the bearing housings.
- Using a bronze drift, remove the shields (5 and 6) by tapping gently on the shield bosses.
- Check that the bearing retainer (53) is smaller in diameter than the stator, otherwise remove the bearing (50) as per the following instructions.
- Remove the rotor (3) from the stator (1) at the drive end, taking care not to touch the winding with the inner bearing retainer if there is no internal turbine.
- Take out the bearings (30) and (50) using a bearing remover, while protecting the end of the shaft extension with a washer. Avoid knocking the running surfaces of the shaft.
- The bearings are removed either separately or with the bearing retainers (33 and 53); to avoid damaging the bearing retainers, heat the outer bearing ring (the bearing should be discarded).
- Recover the preloading washer or springs (59) from the bearing retainer (53).

10.5.2 - Reassembly

- See section 6.1 before reassembly.
- Insert the inner bearing retainer (33) at the rotor drive end and the inner bearing retainer (53) at the non drive end, not forgetting to insert the preloading springs (59).
- Add new grease: the correct amount of new grease for the bearing is 50% of the free space.
- Mount the new bearings (30 and 50) on the shaft, see section 6.3 on mounting bearings.
- Insert the rotor (3) in the stator (1) taking care not to knock the winding.
- Screw a rod with the same thread diameter as the screws (40) and (62) into one of the tapped holes of the bearing retainers (33) and (53) to maintain the position of the grease nipple when remounting the shields (5 and 6).
- Check that the preloading springs are properly installed.
- Fit the NDE shield (6), positioning it on the stator, then mount the fixed valve (55) in the shield bearing housing.
- Mount the mobile valve (56) by either screwing it or locking it, having carefully installed the seal (54) on the valve.
- Mount the outer bearing retainer (52) with the bearing retainer locking screws (62), making sure that the grease drain hole is at the bottom.

- Mount the shield (5) at the drive end, positioning it on the stator, then mount the fixed valve (34) in the shield bearing housing.
- Mount the mobile valve (35) by either screwing it or locking it, having carefully installed the seal (39) on the valve.
- Mount the outer bearing retainer (32) with the bearing retainer locking screws (40), making sure that the grease drain hole is at the bottom.
- Put the tie rods (14) in place, not forgetting the feet of the protective cover (380), tighten the nuts diagonally without locking them so that the feet of the protective cover can be positioned when it is mounted.
- Mount the fan (7) using a drift to bed it in position or by heating the hub of the aluminium fan to approximately 100°C.
- Check that the motor turns freely by hand and that there is no axial play.
- Replace the protective cover (13) and fix it with the screws (27), replace the grease nipple (42) and its extension.
- Tighten the rod nuts (14), always diagonally, up to the torque recommended in section 6.1.
- Replace the key (21).

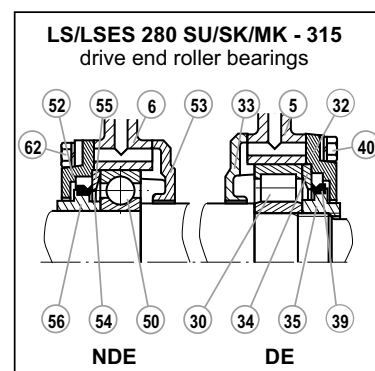
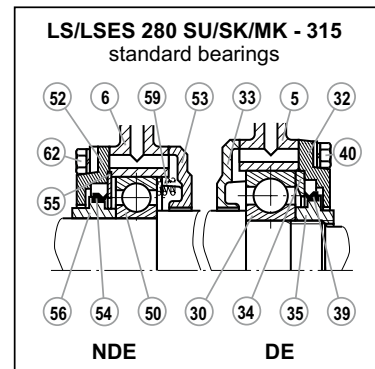

LS/LSES 280 SU/SK/MK, 315 (except SN)

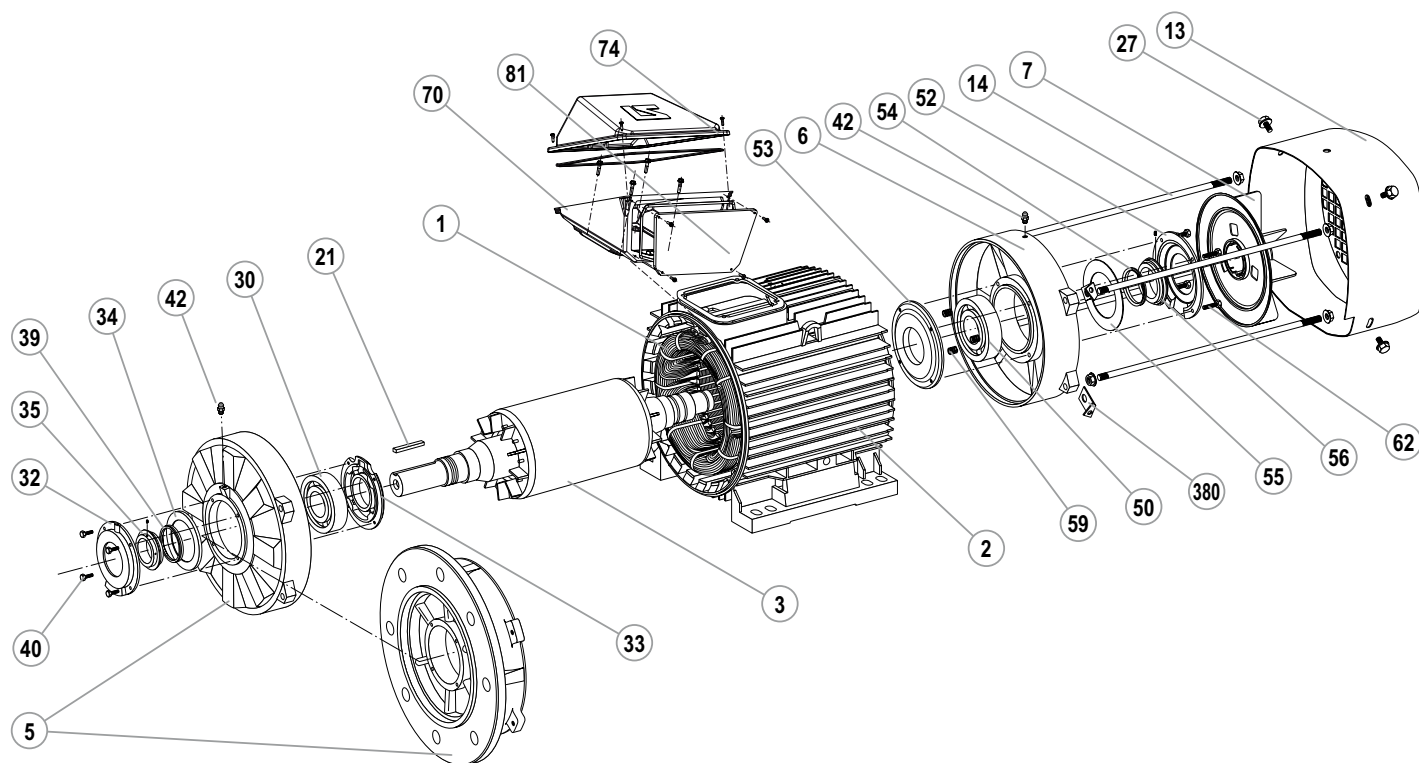

LS/LSES 280 SU/SK/MK, 315 (except SN)

Ref.	Description	Ref.	Description	Ref.	Description
1	Wound stator	30	Drive end bearing	53	Inner non drive end bearing retainer
2	Frame	32	Outer drive end bearing retainer	54	NDE weatherproof seal
3	Rotor	33	Inner drive end bearing retainer	55	Non drive end fixed grease valve
5	Drive end shield	34	Drive end fixed grease valve	56	Non drive end mobile grease valve
6	Non drive end shield	35	Drive end mobile grease valve	59	Preloading washer or spring
7	Fan	39	Drive end seal	62	Cover fixing screw
13	Fan cover	40	Drive end cover fixing screw	70	Terminal box
14	Tie rods	42	Grease nipples	74	Terminal box lid
21	Shaft extension key	50	Non drive end bearing	81	Cable gland support plate
27	Fan cover screw	52	Outer non drive end bearing retainer	380	Protective cover feet

11 - FLS/FLSES MOTORS

11.1 - FLS/FLSES 80 to 132 motors

11.1.1 - Dismantling

- Remove the screws (27) and then take off the cover (13).
 - Pull out the fan (7) using a hub remover or 2 levers (for example, 2 screwdrivers) diametrically opposed to one another, using the shield (6) for support.
 - Remove the tie rods (14).
 - Remove the key (21).
 - Using a wooden mallet, tap the shaft on the fan side in order to loosen the drive end shield (5).
 - Remove the rotor shaft (3) and the DE shield (5) taking care not to knock the winding.
 - Remove the shield on the fan side (6).
 - Recover the preloading (wavy) washer (59) and the NDE shield seal (54).
 - Remove the circlip (60) from flanged motors using angled circlip pliers.
 - Separate the DE shield from the rotor shaft.
 - The shaft can then be seen with its 2 bearings and, if appropriate, the circlip.
- Use a bearing remover to take out the bearings, taking care not to knock the running surfaces of the shaft.

11.1.2 - Reassembling motors without circlip

- Mount the bearings on the rotor shaft.
- Insert the rotor into the stator taking all possible precautions not to knock the winding.
- Mount the DE shield (5).
- Place the preloading washer (59) in the bearing housing, then mount the NDE shield (6).
- Place the tie rods (14) in position and tighten the nuts diagonally up to the recommended torque (see section 6.4).
- Mount the shield seals (39, 54, 308) with grease.
- Mount the fan (7) using a drift to bed it into position.
- Check that the motor turns freely by hand and that there is no radial play.
- Replace the cover (13) and fix it with the screws (27).

11.1.3 - Reassembling motors with flange and circlip

- Mount the DE bearing (30) in the flange (5) using the external slip-ring for support.
- Fit the circlip (60).
- Mount this assembly on the rotor (3) using the inner slip-ring for support.
- Mount the NDE bearing on the rotor.
- Insert the rotor (3) and shield (5) assembly in the stator taking care not to knock the winding.
- Place the preloading washer (59) in the bearing housing, then mount the NDE shield (6).
- Place the tie rods (14) in position and tighten the nuts diagonally up to the recommended torque (see section 6.4).
- Mount the shield seals (39, 54, 308) with grease.
- Mount the fan (7) using a drift to bed it into position.
- Check that the motor turns freely by hand and that there is no axial play.
- Replace the cover (13) and fix it with the screws (27).
- Replace the key (21).

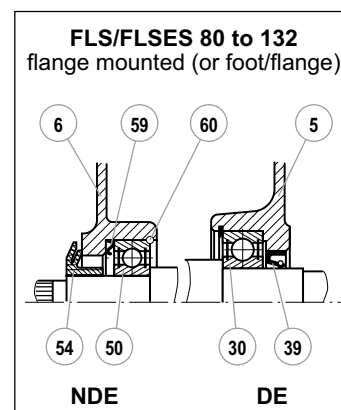
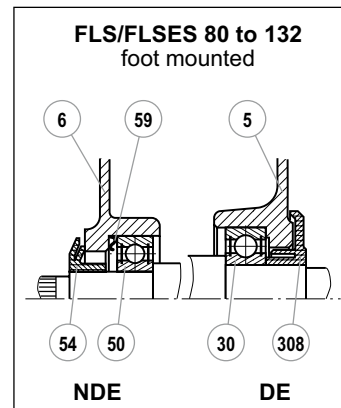

FLS/FLSES 80 to 132

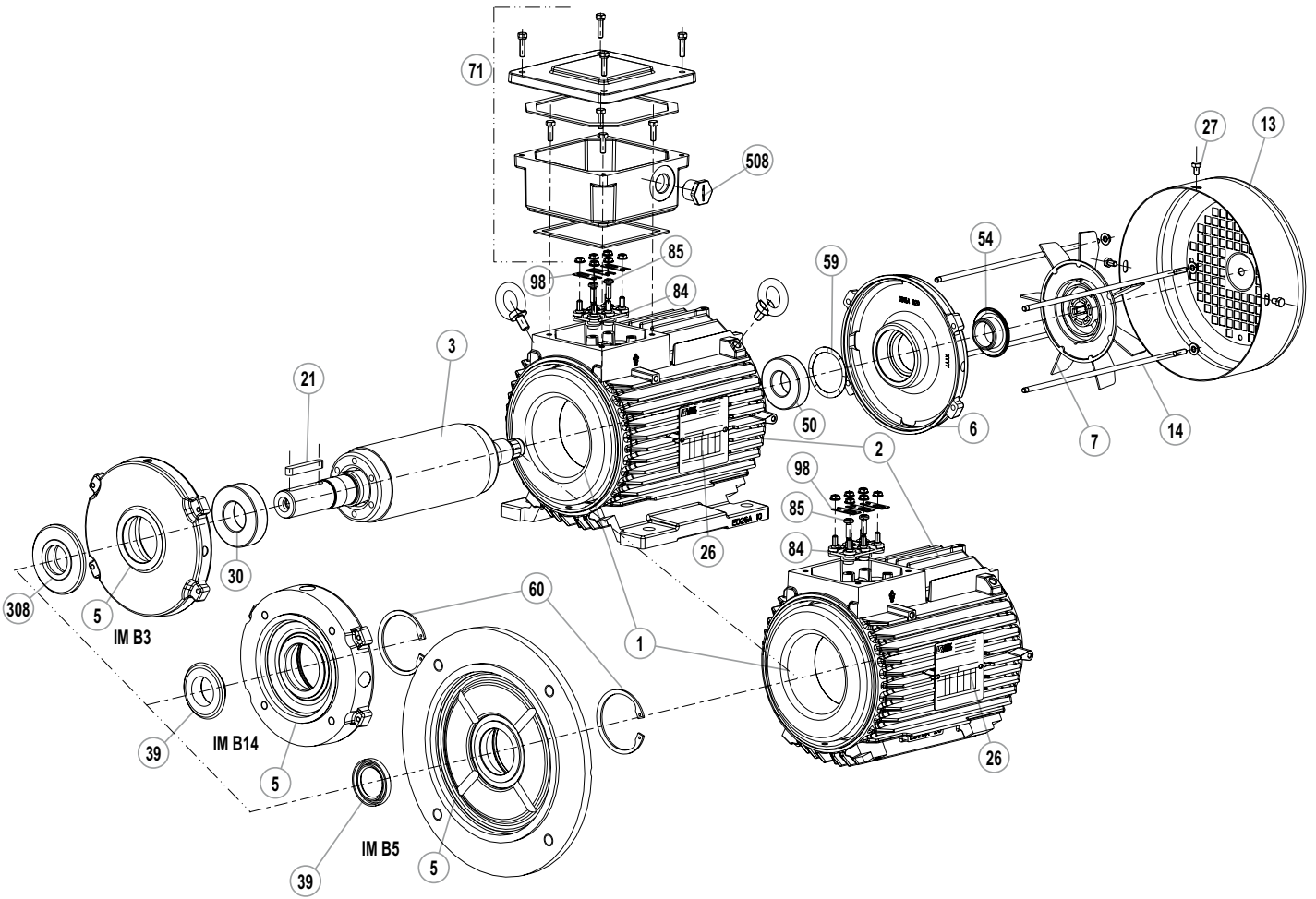

FLS/FLSES 80 to 132

Ref.	Description	Ref.	Description	Ref.	Description
1	Wound stator	21	Shaft extension key	60	Circlip
2	Frame	26	Nameplate	71	FLSES terminal box
3	Rotor	27	Fan cover screw	84	Terminal block
5	Drive end shield	30	Drive end bearing	85	Set screw
6	Non drive end shield	39	Drive end seal	98	Connectors
7	Fan	50	Non drive end bearing	308	Labyrinth seal
13	Fan cover	54	NDE weatherproof seal	508	Terminal box plug
14	Tie rods	59	Preloading (wavy) washer		

11.2 - FLS/FLSES 160, 180 MR motors

11.2.1 - Dismantling

- Remove the screws (27) and then take off the cover (13).
- Pull out the fan (7) using a hub remover or 2 levers diametrically opposed to one another, using the shield (6) for support.
- Take out the key (21) and remove the seals (39 and 54 for foot mounted motors) (54 for flange mounted motors).
- Remove the mounting screws (270 + 273).
- Unscrew the inner bearing retainer (33) fixing screws (40) when using a flange mounted motor or if the drive end bearing is locked.
- Using a bronze drift, remove the shields (5 and 6) by tapping gently on the shield bosses. Recover the preloading washer (59).
- Remove the circlip (38) if necessary (flange mounted motor).
- Remove the rotor (3) from the stator (1) taking care not to touch the winding.
- Take out the bearings (30) and (50) using a bearing remover, while protecting the end of the shaft extension with a washer. Avoid knocking the running surfaces of the shaft.

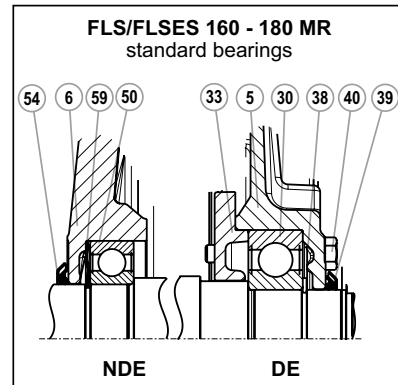

11.2.2 - Reassembly

- See section 6.1 before reassembly.
- If necessary, insert the inner bearing retainer (33) at the rotor drive end, then mount new bearings on the shaft, see section 6.3 mounting bearings.
- Mount the circlip (38) for flange mounted motors.
- Insert the rotor (3) in the stator (1) taking care not to knock the winding.
- Position the preloading washer (59) with a small amount of grease in the back of the bearing cage of the NDE shield (6), then remount the NDE shield (6), positioning it on the stator.
- If there is a bearing retainer (33), screw a rod with the same thread diameter as the screws (40) into one of the tapped holes of the bearing retainer to maintain its angular position when remounting the DE shield (5).
- Remount the shield (5) taking care to allow for the positioning of a bearing retainer if used.
- Place the mounting screws (14) in position and tighten the nuts diagonally up to the recommended torque (see section 6.1).
- If necessary, fix the bearing retainer (33) with its own screws.
- Mount the shield seals with grease: (54 at the non drive end) (39 at the drive end for foot mounted motors).
- Mount the fan (7) using a drift to bed it into position.
- Check that the rotor turns freely by hand (that there is no axial play if there is a locked end shield).
- Replace the cover (13) and fix it with the screws (27).
- Replace the key (21).

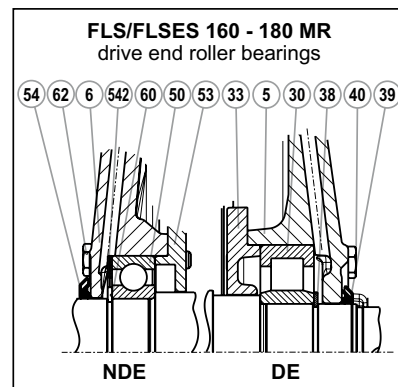

FLS/FLSES 160, 180 MR

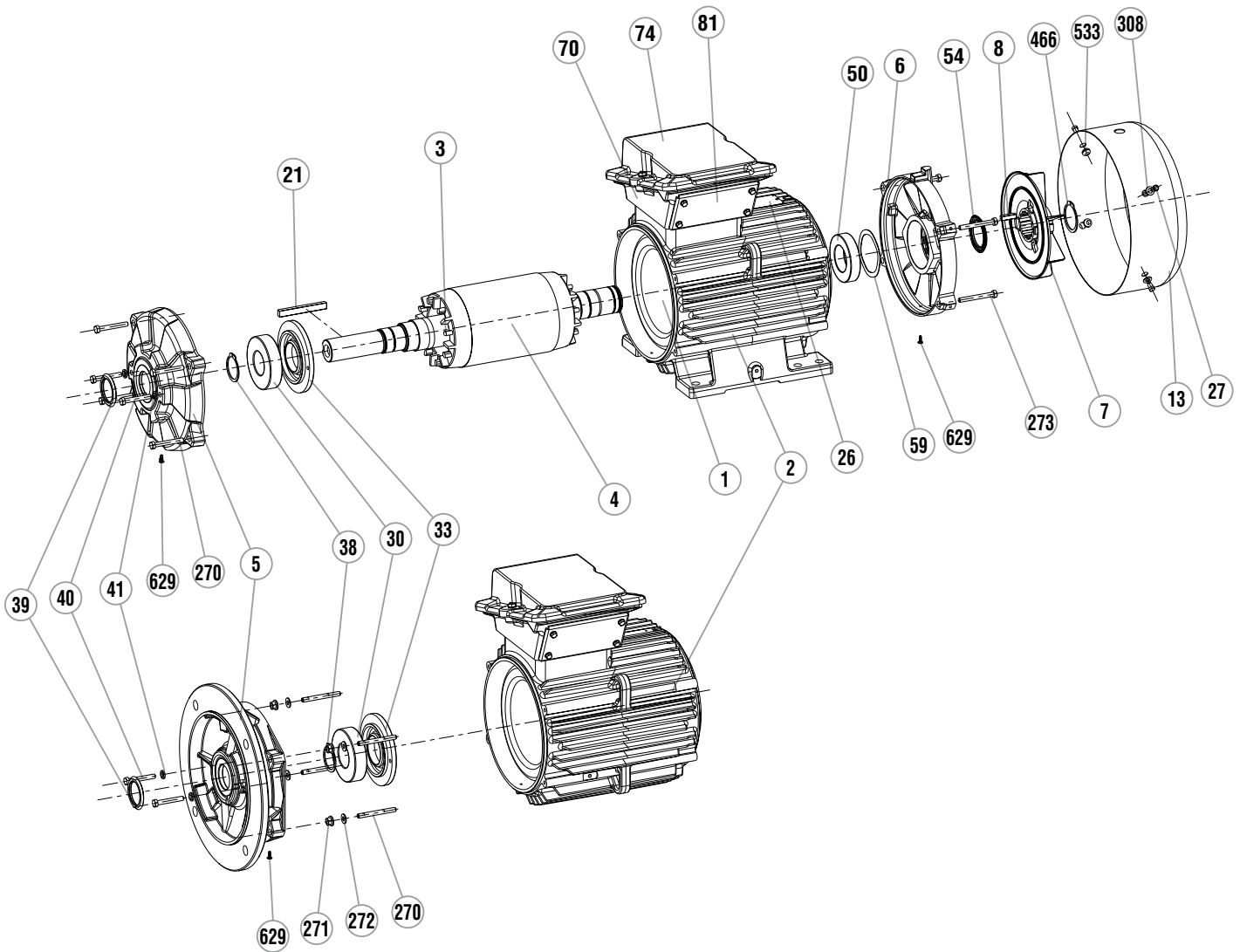

FLS/FLSES 160, 180 MR

Ref.	Description	Ref.	Description	Ref.	Description
1	Wound stator	27	Fan cover screw	74	Terminal box lid
2	Frame	30	Drive end bearing	81	Cable gland support plate
3	Shaft	33	Inner drive end bearing retainer	270	Drive end shield fixing screw
4	Rotor	38	Snap ring for drive end shaft	271	Drive end shield fixing nut
5	Drive end shield	39	Drive end seal	272	DE shield washer
6	Non drive end shield	40	Drive end cover fixing screw	273	Non drive end shield fixing screw
7	Fan	41	Leaktight toothed lock washer for DE bearing retainer	308	Cover fixing washer
8	Fan key	50	Non drive end bearing	466	Snap ring for fan
13	Fan cover	54	NDE weatherproof seal	533	Cover shock mount
21	Drive end shield shaft extension key	59	Preloading (wavy) washer	629	Draining plug
26	Nameplate	70	Terminal box		

11.3 - FLS/FLSES 180 M/L/LUR, 200 LU, 225 MR/SR motors

11.3.1 - Dismantling

- Remove the screws (27) and then take off the cover (13).
- Pull out the fan (7) using a hub remover or 2 levers diametrically opposed to one another, using the shield (6) for support.
- Take out the key (21) and remove the seals (39 and 54 for foot mounted motors) (54 for flange mounted motors).
- Remove the mounting screws (270 + 273).
- Unscrew the inner bearing retainer (33) fixing screws (40) when using a flange mounted motor or if the drive end bearing is locked.
- Using a bronze drift, remove the shields (5 and 6) by tapping gently on the shield bosses. Recover the preloading washer (59).
- Remove the circlip (38) if necessary (flange mounted motor).
- Remove the rotor (3) from the stator (1) taking care not to touch the winding.
- Take out the bearings (30) and (50) using a bearing remover, while protecting the end of the shaft extension with a washer. Avoid knocking the running surfaces of the shaft.

11.3.2 - Reassembly

- See section 6.1 before reassembly.
- If necessary, insert the inner bearing retainer (33) at the rotor drive end, then mount new bearings on the shaft, see section 6.3 mounting bearings.
- Mount the circlip (38) for flange mounted motors.
- Insert the rotor (3) in the stator (1) taking care not to knock the winding.
- Position the preloading washer (59) with a small amount of grease in the back of the bearing cage of the NDE shield (6), then remount the NDE shield (6), positioning it on the stator.
- If there is a bearing retainer (33), screw a rod with the same thread diameter as the screws (40) into one of the tapped holes of the bearing retainer to maintain its angular position when remounting the DE shield (5).
- Remount the shield (5) taking care to allow for the positioning of a bearing retainer if used.
- Place the mounting screws (14) in position and tighten the nuts diagonally up to the recommended torque (see section 6.1).
- If necessary, fix the bearing retainer (33) with its own screws.
- Mount the shield seals with grease: (54 at the non drive end) (39 at the drive end for foot mounted motors).
- Mount the fan (7) using a drift to bed it into position.
- Check that the rotor turns freely by hand (that there is no axial play if there is a locked end shield).
- Replace the cover (13) and fix it with the screws (27).
- Replace the key (21).

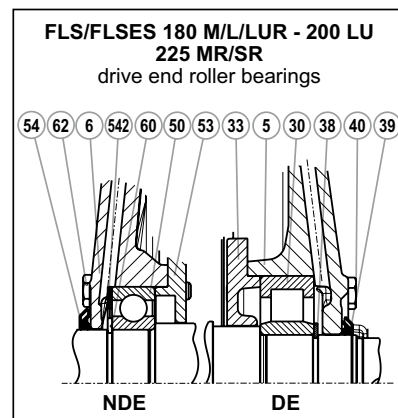
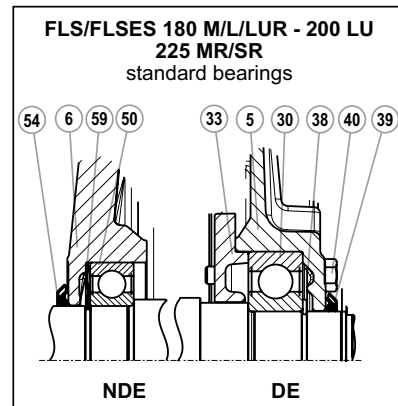

FLS/FLSES 180 M/L/LUR, 200 LU, 225 MR/SR

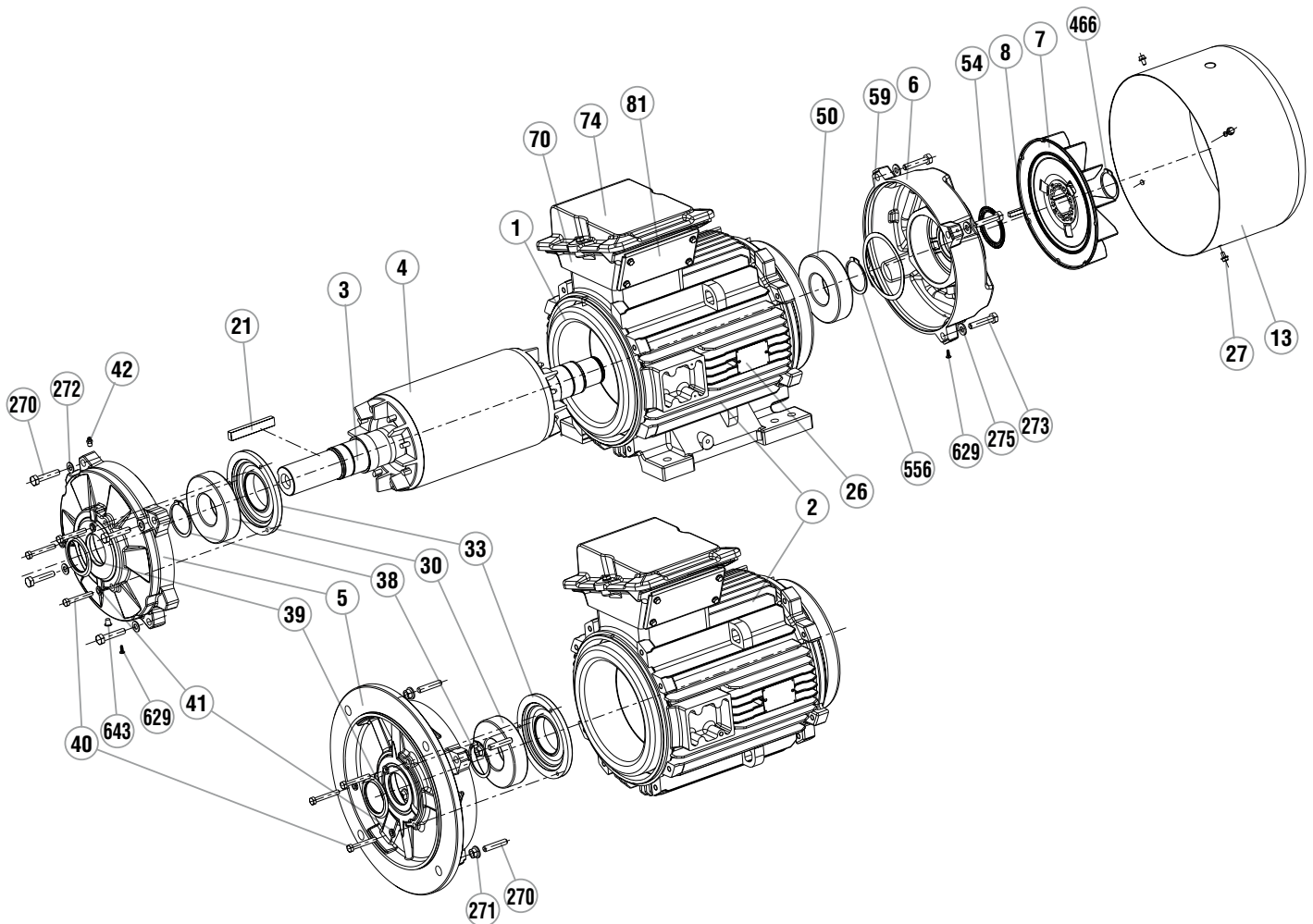

FLS/FLSES 180 M/L/LUR, 200 LU, 225 MR/SR

Ref.	Description	Ref.	Description	Ref.	Description
1	Wound stator	30	Drive end bearing	81	Cable gland support plate
2	Frame	33	Inner drive end bearing retainer	270	Drive end shield fixing screw
3	Shaft	38	Snap ring for drive end shaft	271	Drive end shield fixing nut
4	Rotor	39	Drive end seal	272	DE shield washer
5	Drive end shield	40	Drive end cover fixing screw	273	Non drive end shield fixing screw
6	Non drive end shield	41	Leaktight toothed lock washer for DE bearing retainer	275	Fixing washer for NDE shield
7	Fan	42	Drive end grease nipples	466	Snap ring for fan
8	Fan key	50	Non drive end bearing	556	NDE bearing circlip
13	Fan cover	54	NDE weatherproof seal	629	Draining plug
21	Drive end shield shaft extension key	59	Preloading (wavy) washer	643	DE grease draining plug
26	Nameplate	70	Terminal box		
27	Fan cover screw	74	Terminal box lid		

11.4 - FLS/FLSES 225 M to 280 motors

11.4.1 - Dismantling the NDE shield

- Remove the fixing screws (27) and then take off the cover (13).
- Remove the shaft extension screw if necessary.
- Take out the fan (7).
- Remove the fixing screws from the inner NDE bearing retainer (53).
- Remove the fixing screws (273) from the NDE shield (6).
- Remove the fan key if appropriate.
- Using two levers or a flexible hammer, disengage the NDE shield (6) taking care not to place it aslant. Remove the shield by sliding it along the shaft.
- Put the dismantled components to one side and recover the preloading washer (59), which should be replaced in its housing.

11.4.2 - Dismantling the DE shield

- Dismantle the DE shield without removing the rotor (3). To do this:
- Remove the fixing screws (270) from the DE shield (5).
- Remove the fixing screws (40) from the DE internal cover (33).
- Take out the key (21).
- Using two levers or a flexible hammer, disengage the DE shield (5) taking care not to place it aslant.
- Remove the shield by sliding it along the shaft.

11.4.3 - Changing the antifriction bearings

- Using an appropriate lifting tool, take out the rotor without knocking the winding.
- Take off the DE circlip (38).
- Remove the bearings (30) and (50) with an appropriate tool, protecting the end of the shaft extension. Avoid knocking the running surfaces of the shaft.
- Change the bearings in accordance with the instructions described in the General information in section 6 (shrinkfitting only).

IMPORTANT : Before undertaking any of these procedures, read the «CHECKS BEFORE REASSEMBLY» section.

11.4.4 - Reassembly

- Mount the DE bearing (30) on the rotor shaft (take care not to forget the inner bearing retainer (33) and the circlip (38)!), and also the NDE bearing (50) if and only if the stator inner \varnothing allows the inner NDE bearing retainer (53) to pass through.
- Insert the rotor into the stator taking care not to knock the winding. Install the NDE bearing if this has not already been done.
- Fill the decompression grooves (416) located in the shaftway with grease.
- Present the shields, grease nipples facing upwards. Begin with the DE shield (5). Fix a dowel pin in one of the inner bearing retainer (33) tapped holes **so that the grease inlet pipes fully correspond.**
- End with the NDE shield (6). Fix a dowel pin in one of the inner bearing retainer (53) tapped holes **so that the grease inlet pipes fully correspond.**
- Lift the rotor slightly and fit the shields in place.

From now on, we recommend checking at every step that the rotor turns freely by hand before continuing to the next instruction.

- Replace the shield fixing screws (270) and (273).
- Insert the fixing screws on the inner bearing retainers (33) and (53). Replace the AZ washers to ensure a perfect seal.
- Replace the fan key if appropriate.
- Replace the fan (7).
- Replace the shaft extension screw if necessary.
- Replace the cover (13) and reinsert the fixing screws (27).
- Lubricate the DE and NDE antifriction bearings, turning the shaft by hand.

Initial grease volume for ball bearings:

- Frame 225 - 250 : DE = 239 cm³ (210 g) / NDE = 267 cm³ (267 g)
- Frame 280 : DE = 228 cm³ (201 g) / NDE = 159 cm³ (140 g)

This initial quantity corresponds to the amount of grease contained inside the bearing as well as the grease located outside the bearing. The weight expressed in grams refers to the original standard grease, the name of which is indicated on the motor nameplate.

The filling of the lubrication channel is not included in this initial volume. It is carried out during the preparation of the bearing housing (5 and 6) at reassembly and consists of filling the channel until clean grease appears at the opposite end.

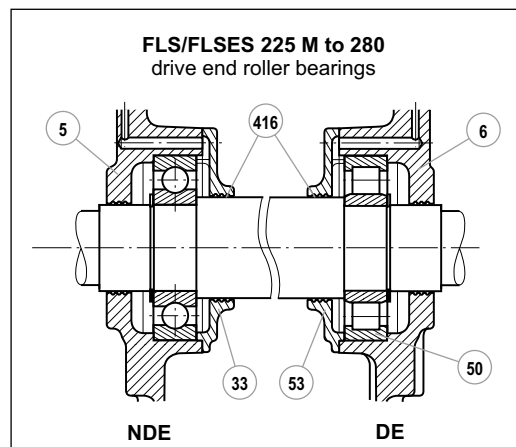
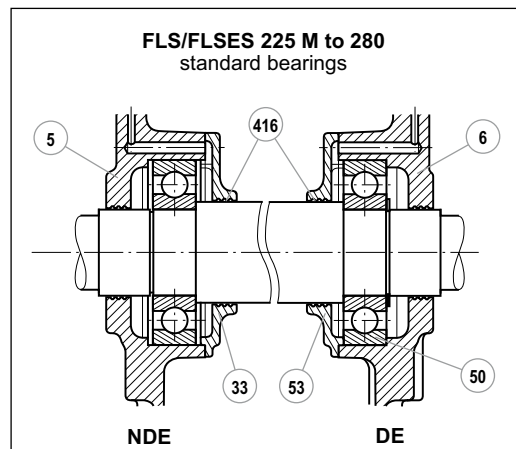

FLS/FLSES 225 M to 280

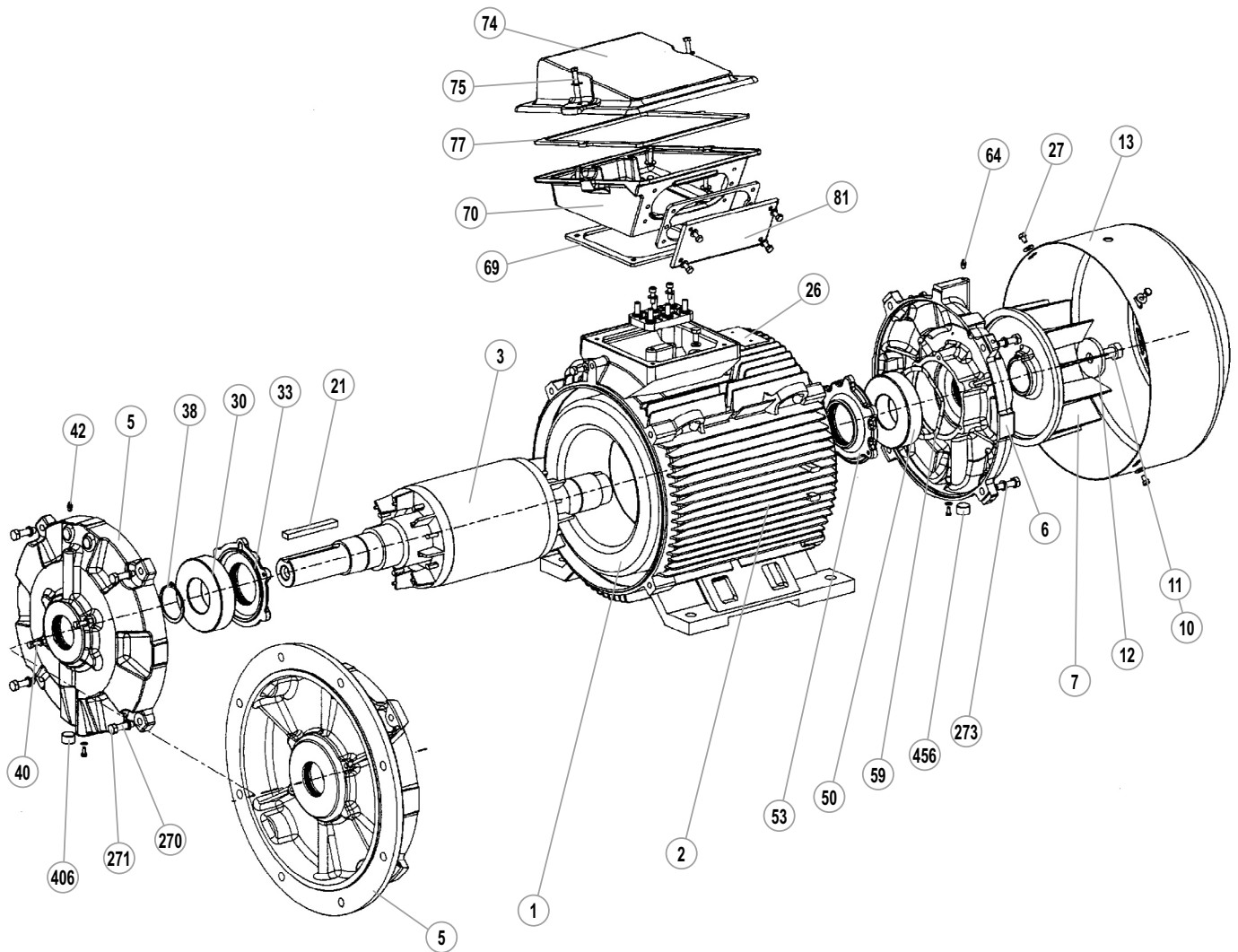

FLS/FLSES 225 M to 280

Ref.	Description	Ref.	Description	Ref.	Description
1	Wound stator	26	Nameplate	69	Terminal box base seal
2	Frame	27	Fan cover screw	70	Terminal box
3	Rotor	30	Drive end bearing	74	Terminal box lid
5	Drive end shield	33	Inner drive end bearing retainer	75	Terminal box lid fixing screw
6	Non drive end shield	38	Snap ring for drive end shaft	77	Terminal box lid seal
7	Fan	40	Drive end cover fixing screw	81	Cable gland support plate
10	Turbine or fan screw	42	Drive end grease nipples	270	Drive end shield fixing screw
11	Lockwasher	50	Non drive end bearing	271	Drive end shield fixing nut
12	Lock washer	53	Inner non drive end bearing retainer	273	Non drive end shield fixing screw
13	Fan cover	59	Preloading (wavy) washer	406	Drive end grease valve cover plate (plug)
21	Drive end shield shaft extension key	64	Non drive end grease nipple	456	Non drive end grease valve cover plate (plug)

11.5 - FLS/FLSES 315 to 355 LD motors

11.5.1 - Dismantling the NDE shield

- Remove the fixing screws (27) and then take off the cover (13).
- Remove the shaft extension screw if necessary.
- Take out the fan (7).
- Remove the fixing screws from the inner NDE bearing retainer (53).
- Remove the fixing screws (273) from the NDE shield (6).
- Remove the fan key if appropriate.
- Using two levers or a flexible hammer, disengage the NDE shield (6) taking care not to place it aslant. Remove the shield by sliding it along the shaft.
- Put the dismantled components to one side and retrieve the preloading springs (256), which should be replaced in their housing.

11.5.2 - Dismantling the DE shield

- Dismantle the DE shield without removing the rotor (3). To do this:
- Remove the fixing screws (270) from the DE shield (5).
- Remove the fixing screws (40) from the DE internal cover (33).
- Take out the key (21).
- Using two levers or a flexible hammer, disengage the DE shield (5) taking care not to place it aslant.
- Remove the shield by sliding it along the shaft.

11.5.3 - Changing the antifriction bearings

- Using an appropriate lifting tool, take out the rotor without knocking the winding.
- Remove the DE (38) and NDE (60) circlips.
- Remove the bearings (30) and (50) with an appropriate tool, protecting the end of the shaft extension. Do not knock the running surfaces of the shaft.
- Change the bearings in accordance with the instructions described in the General information in section 6 (shrinkfitting only).

IMPORTANT : Before undertaking any of these procedures, read the «**CHECKS BEFORE REASSEMBLY**» section.

11.5.4 - Reassembly

- Mount the DE bearing (30) on the rotor shaft (take care not to forget the inner bearing retainer (33) and the circlip (38)!), and also the NDE bearing (50) if and only if the stator inner \varnothing allows the inner NDE bearing retainer (53) to pass through, refit the circlip (60), refit the preloading springs in their housing in the inner NDE bearing retainer (53).
- Insert the rotor into the stator taking care not to knock the winding. Install the NDE bearing if this has not already been done.
- Fill the decompression grooves (416) located in the shaftway and the grease inlet pipes with grease.
- Present the shields, grease nipples facing upwards. Begin with the DE shield (5). Fix a dowel pin in one of the inner bearing retainer (33) tapped holes **so that the grease inlet pipes fully correspond**.
- End with the NDE shield (6). Fix a dowel pin in one of the inner bearing retainer (53) tapped holes **so that the grease inlet pipes fully correspond**.
- Lift the rotor slightly and fit the shields in place.

From now on, we recommend checking at every step that the rotor turns freely by hand before continuing to the next instruction.

- Replace the shield fixing screws (270) and (273).
- Insert the fixing screws on the inner bearing retainers (33) and (53). Replace the AZ washers to ensure a perfect seal.
- Replace the fan key if appropriate.
- Replace the fan (7).
- Replace the shaft extension screw if necessary.
- Replace the cover (13) and reinsert the fixing screws (27).
- Lubricate the DE and NDE antifriction bearings, turning the shaft by hand.

Initial grease volume for ball bearings:

- Frame 315-355 2P: DE = 139 cm³ (122g) / NDE = 228 cm³ (201g)
- Frame 315 4P: DE = 440 cm³ (500g) / NDE = 228 cm³ (201g)
- Frame 355 4P: DE = 599 cm³ (680g) / NDE = 228 cm³ (201g)

This initial quantity corresponds to the amount of grease contained inside the bearing as well as the grease located outside the bearing. The weight expressed in grams refers to the original standard grease, the name of which is indicated on the motor nameplate.

The filling of the lubrication channel is not included in this initial volume. It is carried out during the preparation of the bearing housing (5 and 6) at reassembly and consists of filling the channel until clean grease appears at the opposite end.

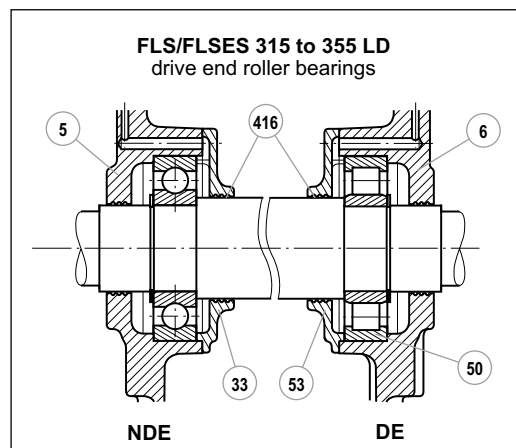
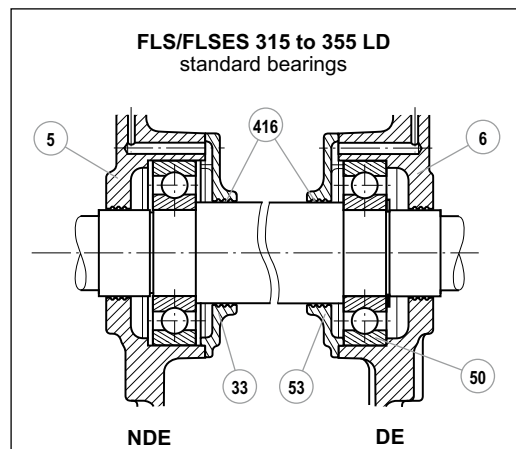

FLS/FLSES 315 to 355 LD

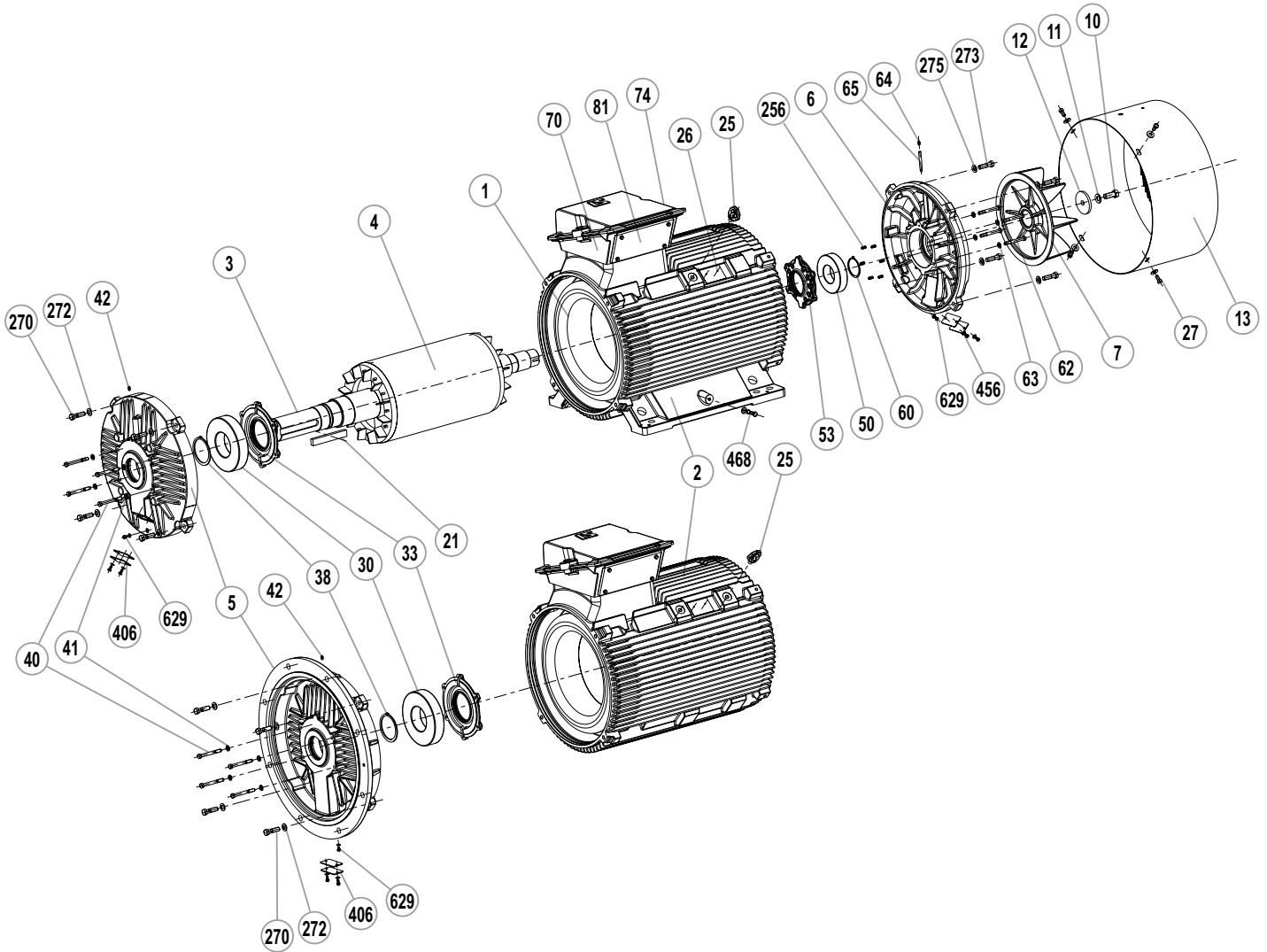

FLS/FLSES 315 to 355 LD

Ref.	Description	Ref.	Description	Ref.	Description
1	Wound stator	27	Fan cover screw	70	Stator terminal box
2	Frame	30	Drive end bearing	74	Stator terminal box lid
3	Shaft	33	Inner drive end bearing retainer	81	Cable gland support plate
4	Rotor	38	Snap ring for drive end shaft	256	Preloading spring
5	Drive end shield	40	Drive end cover fixing screw	270	Drive end shield fixing screw
6	Non drive end shield	41	Leaktight toothed lock washer for DE bearing retainer	272	DE shield washer
7	Fan	42	Drive end grease nipples	273	Non drive end shield fixing screw
10	Turbine or fan screw	50	Non drive end bearing	275	Fixing washer for NDE shield
11	Lockwasher	53	Inner non drive end bearing retainer	406	Drive end grease valve cover plate
12	Lock washer	60	Circlip	456	Non drive end grease valve cover plate
13	Fan cover	62	Cover fixing screw	468	Earth terminal plug
21	Drive end shield shaft extension key	63	Fixing washer for NDE bearing retainer	629	Draining plug
25	Lifting ring	64	Non drive end grease nipple		
26	Nameplate	65	Extension for non drive end grease nipple		

12 - CILS MOTORS

12.1 - CILS 225 motors

12.1.1 - Dismantling the NDE shield

- Remove the fixing screws and then take off the cover (13).
- Remove the shaft extension screw if necessary.
- Remove the circlips (466) and take out the fan (7).
- Remove the NDE seal (54)
- Remove the fixing screws from the NDE shield (6).
- Remove the fan key (8) if appropriate.
- Using two levers or a flexible hammer, disengage the NDE shield (6) taking care not to place it aslant. Remove the shield by sliding it along the shaft.
- Put the dismantled components to one side and recover the preloading washer (59), which should be replaced in its housing.

12.1.2 - Dismantling the DE shield

Dismantle the DE shield without removing the rotor (3).

To do this :

- Remove the DE seal (39)
- Remove the fixing screws from the DE shield (5).
- Remove the fixing screws from the DE internal cover (33).
- Take out the key (21).
- Using two levers or a flexible hammer, disengage the DE shield (5) taking care not to place it aslant
- Remove the shield by sliding it along the shaft

12.1.3 - Replacement of bearings

- Using an appropriate lifting tool, take out the rotor without knocking the winding.
- Take off the DE circlip (60).
- Remove the bearings (30) and (50) with an appropriate tool, protecting the end of the shaft extension. Avoid knocking the running surfaces of the shaft.
- Change the bearings in accordance with the instructions described in the General information in section 6 (shrinkfitting only).

IMPORTANT: Before undertaking any of these procedures, read the «CHECKS BEFORE REASSEMBLY» section.

12.1.4 - Reassembly

- Mount the new DE bearing (30) on the rotor shaft (take care not to forget the inner bearing retainer (33) and the circlip (60)!), and the new NDE bearing (50).
- Insert the rotor into the stator taking care not to knock the winding. Install the NDE bearing (50) if this has not already been done.
- Fill the decompression grooves located in the shaftway with grease.
- Present the shields, grease nipples facing upwards. Begin with the DE shield (5). Fix a dowel pin in one of the inner bearing retainer (33) tapped holes so that the grease inlet pipes fully correspond.
- End with the NDE shield (6).
- Lift the rotor slightly and fit the shields in place.

From now on, we recommend checking at every step that the rotor turns freely by hand before continuing to the next instruction.

- Replace the shield fixing screws on DE and NDE shields.
- Insert the fixing screws on the inner bearing retainers (33) and replace the AZ washers to ensure a perfect seal.
- Replace the fan key (8) if appropriate.
- Replace the fan (7).
- Replace the shaft extension screw if necessary.
- Replace the fan cover (13) and reinsert the fixing screws

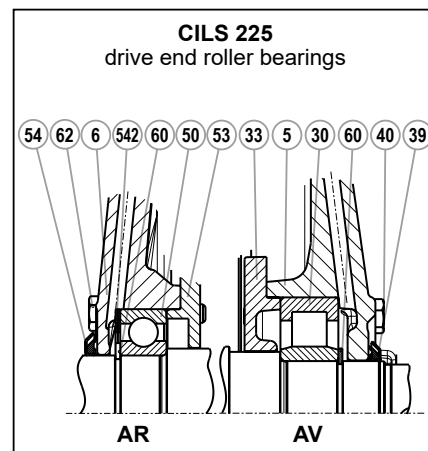
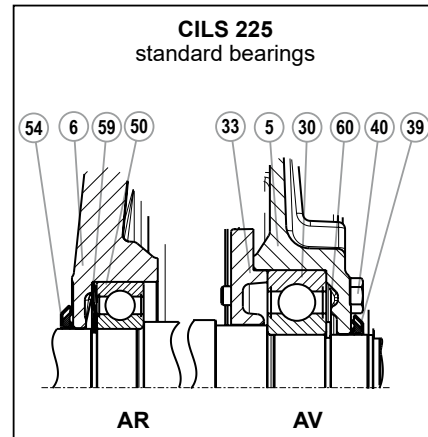

CILS 225 S/M

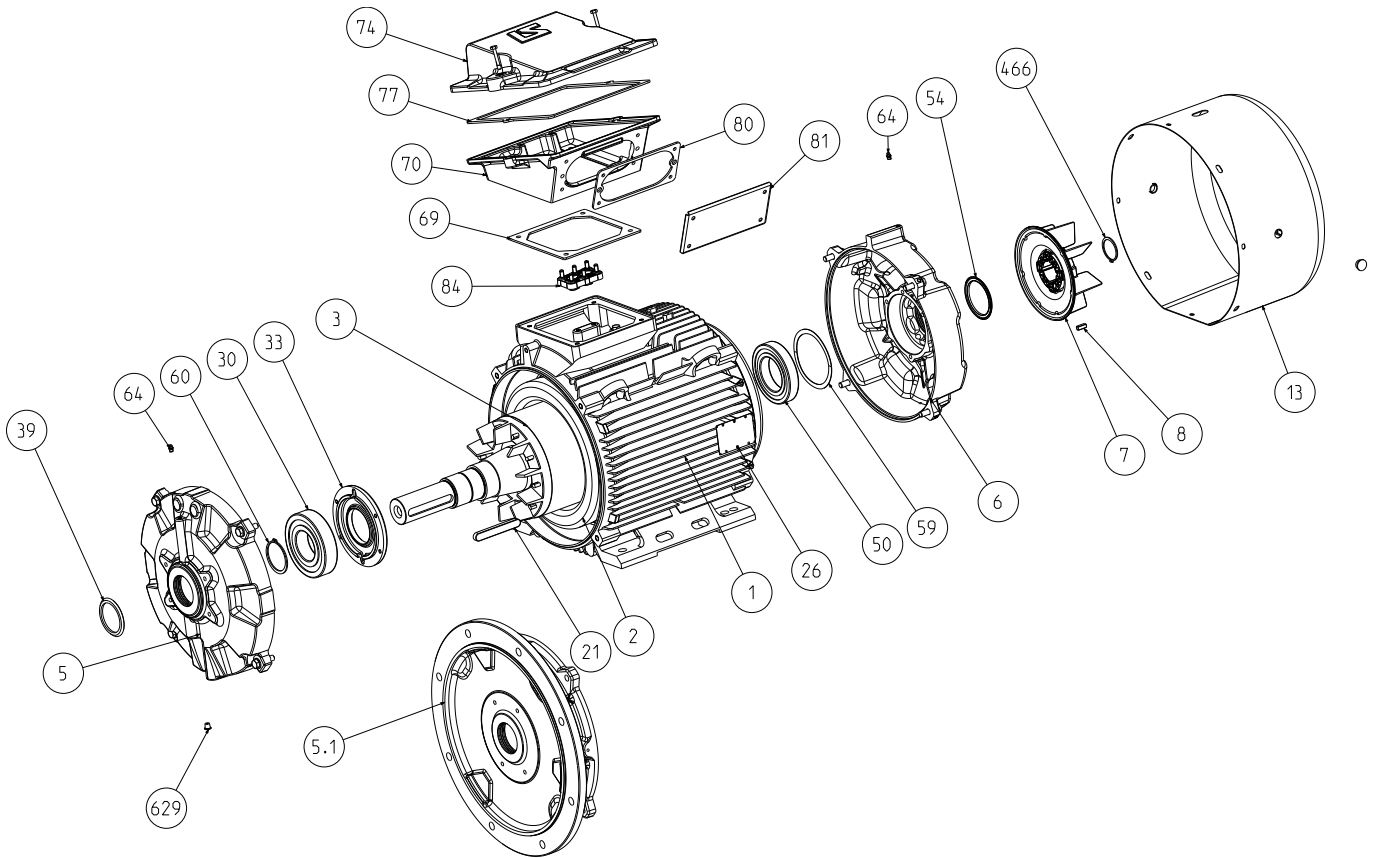

CILS 225 S/M

Ref.	Description	Ref.	Description	Ref.	Description
1	Housing	26	Nameplate	70	Terminal box housing
2	Wound stator	30	Drive end bearing	74	Terminal box cover
3	Rotor	33	Inner drive end bearing retainer	77	Terminal box cover seal
5	Drive end shield	39	Drive end seal	80	Cable gland support plate seal
6	Non drive end shield	54	Non drive end seal	81	Cable gland support plate
7	Fan	59	Preloading washer	84	Terminal board
8	Fan key	60	Snap ring for drive end shaft	466	Fan snap ring
13	Fan cover	64	Grease nipple	629	Drain plug
21	Drive end shield shaft extension key	69	Terminal box base seal		

12.2 - CILS 250 motors

12.2.1 - Dismantling the NDE shield

- Remove the fixing screws and then take off the cover (13).
- Remove the shaft extension screw if necessary.
- Remove the circlips (466) and take out the fan (7).
- Remove the fixing screws from the inner NDE bearing retainer (53).
- Remove the fixing screws from the NDE shield (6).
- Remove the fan key (8) if appropriate.
- Using two levers or a flexible hammer, disengage the NDE shield (6) taking care not to place it aslant. Remove the shield by sliding it along the shaft.
- Put the dismantled components to one side and recover the preloading washer (59), which should be replaced in its housing.

12.2.2 - Dismantling the DE shield

Dismantle the DE shield without removing the rotor (3).

To do this :

- Remove the fixing screws from the DE shield (5).
- Remove the fixing screws from the DE internal cover (33).
- Take out the key (21).
- Using two levers or a flexible hammer, disengage the DE shield (5) taking care not to place it aslant
- Remove the shield by sliding it along the shaft

12.2.3 - Replacement of bearings

- Using an appropriate lifting tool, take out the rotor without knocking the winding.
- Take off the DE circlip (60).
- Remove the bearings (30) and (50) with an appropriate tool, protecting the end of the shaft extension. Avoid knocking the running surfaces of the shaft.
- Change the bearings in accordance with the instructions described in the General information in section 6 (shrinkfitting only).

IMPORTANT: Before undertaking any of these procedures, read the «CHECKS BEFORE REASSEMBLY» section.

12.2.4 - Reassembly

- Mount the DE bearing (30) on the rotor shaft (take care not to forget the inner bearing retainer (33) and the circlip (60)!), and also the NDE bearing (50) if and only if the stator inner Ø allows the inner NDE bearing retainer (53) to pass through.
- Insert the rotor into the stator taking care not to knock the winding. Install the NDE bearing (50) if this has not already been done.
- Fill the decompression grooves located in the shaftway with grease.
- Present the shields, grease nipples facing upwards. Begin with the DE shield (5). Fix a dowel pin in one of the inner bearing retainer (33) tapped holes so that the grease inlet pipes fully correspond.
- End with the NDE shield (6). Fix a dowel pin in one of the inner bearing retainer (53) tapped holes so that the grease inlet pipes fully correspond.
- Lift the rotor slightly and fit the shields in place.

From now on, we recommend checking at every step that the rotor turns freely by hand before continuing to the next instruction.

- Replace the shield fixing screws on DE and NDE shields.
- Insert the fixing screws on the inner bearing retainers (33) and (53). Replace the AZ washers to ensure a perfect seal
- Replace the fan key (8) if appropriate.
- Replace the fan (7).
- Replace the shaft extension screw if necessary.
- Replace the fan cover (13) and reinsert the fixing screws
- Lubricate the DE and NDE bearings, turning the shaft by hand.

Initial grease volume for ball bearings:

- Frame 250 : DE = 294 cm³ (259g) / NDE = 161 cm³ (141g)

This initial quantity corresponds to the amount of grease contained inside the bearing as well as the grease located outside the bearing. The weight expressed in grams refers to the original standard grease, the name of which is indicated on the motor nameplate.

The filling of the lubrication channel is not included in this initial volume. It is carried out during the preparation of the bearing housing (5 and 6) at reassembly and consists of filling the channel until clean grease appears at the opposite end.

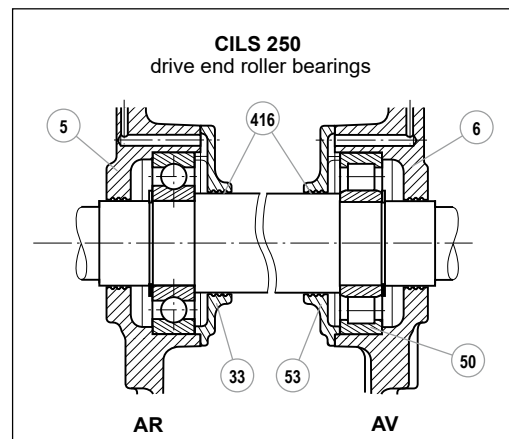
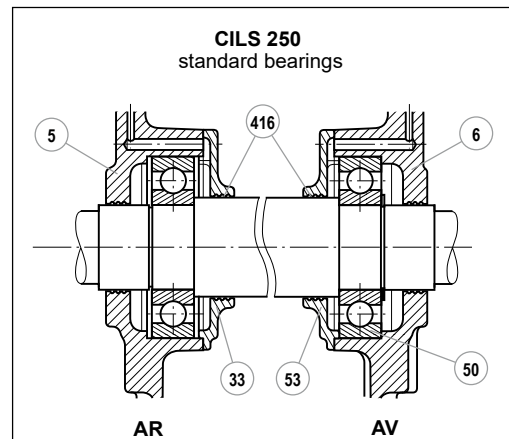

CILS 250 M

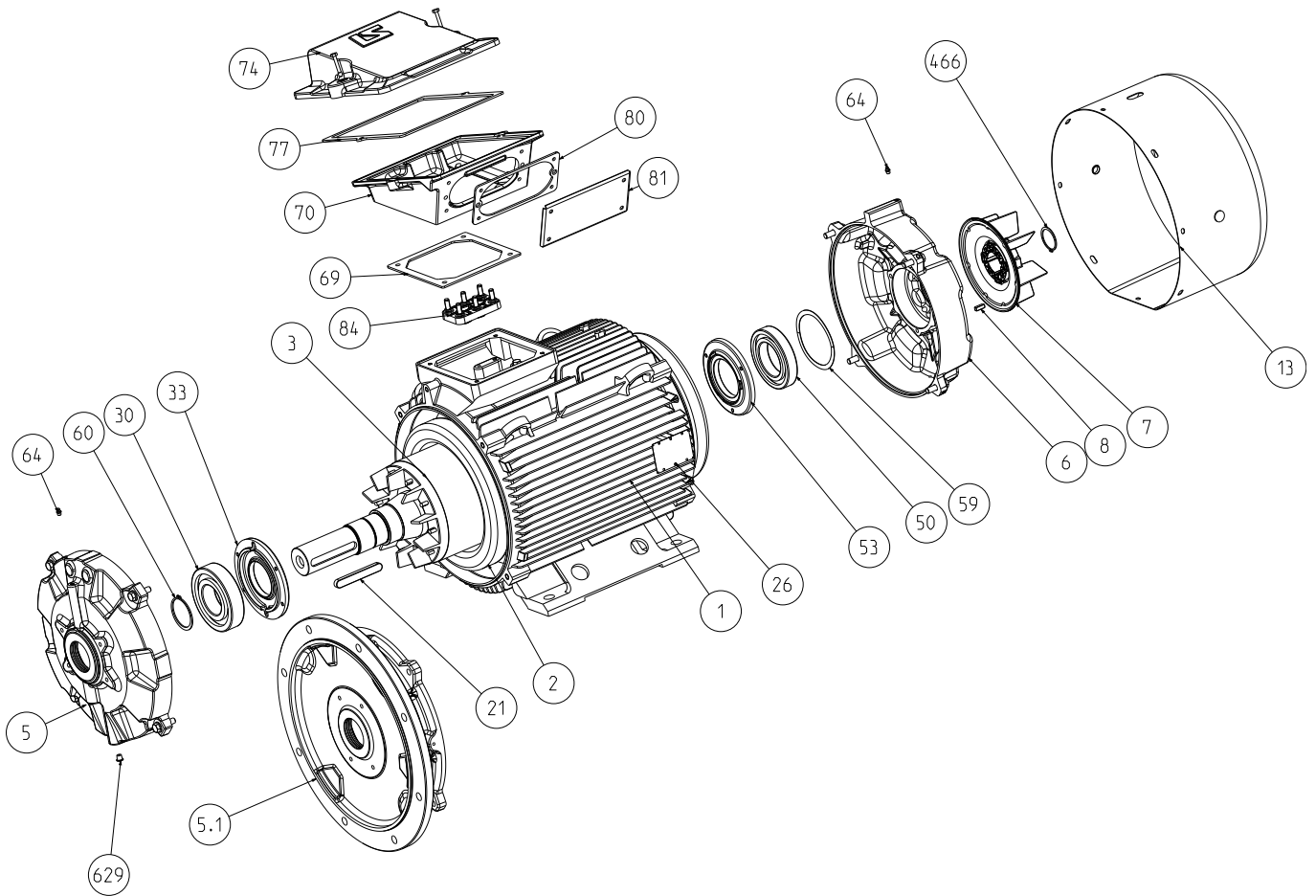

CILS 250

Ref.	Description	Ref.	Description	Ref.	Description
1	Housing	26	Nameplate	70	Terminal box housing
2	Wound stator	30	Drive end bearing	74	Terminal box cover
3	Rotor	33	Inner drive end bearing retainer	77	Terminal box cover seal
5	Drive end shield	50	Non drive end bearing	80	Cable gland support plate seal
6	Non drive end shield	53	Inner non drive end bearing retainer	81	Cable gland support plate
7	Fan	59	Preloading washer	84	Terminal board
8	Fan key	60	Snap ring	466	Fan snap ring
13	Fan cover	64	Grease nipple	629	Drain plug
21	Drive end shield shaft extension key	69	Terminal box base seal		

12.3 - CILS 280 to 315 motors

12.3.1 - Dismantling the NDE shield

- Remove the fixing screws and then take off the cover (13).
- Remove the shaft extension screw if necessary.
- Remove the circlips (466) and take out the fan (7).
- Remove the fixing screws from the inner NDE bearing retainer (53).
- Remove the fixing screws from the NDE shield (6).
- Remove the fan key (8) if appropriate.
- Using two levers or a flexible hammer, disengage the NDE shield (6) taking care not to place it aslant. Remove the shield by sliding it along the shaft.
- Put the dismantled components to one side and recover the preloading springs (59), which should be replaced in their housing.

12.3.2 - Dismantling the DE shield

Dismantle the DE shield without removing the rotor (3).

To do this :

- Remove the fixing screws from the DE shield (5).
- Remove the fixing screws from the DE internal cover (33).
- Take out the key (21).
- Using two levers or a flexible hammer, disengage the DE shield (5) taking care not to place it aslant.
- Remove the shield by sliding it along the shaft.

12.3.3 - Replacement of bearings

- Using an appropriate lifting tool, take out the rotor without knocking the winding.
- Take off the DE and NDE circlip (60).
- Remove the bearings (30) and (50) with an appropriate tool, protecting the end of the shaft extension. Avoid knocking the running surfaces of the shaft.
- Change the bearings in accordance with the instructions described in the General information in section 6 (shrinkfitting only).

IMPORTANT: Before undertaking any of these procedures, read the «CHECKS BEFORE REASSEMBLY» SECTION.

12.3.4 - 12.3.4 - Reassembly

- Mount the DE bearing (30) on the rotor shaft (take care not to forget the inner bearing retainer (33) and the circlip (60)!), and also the NDE bearing (50) if and only if the stator inner Ø allows the inner NDE bearing retainer (53) to pass through, refit the circlip (60), refit the preloading springs in their housing in the inner NDE bearing retainer (53).
- Insert the rotor into the stator taking care not to knock the winding. Install the NDE bearing (50) if this has not already been done.
- Fill the decompression grooves (416) located in the shaftway with grease.
- Present the shields, grease nipples facing upwards. Begin with the DE shield (5). Fix a dowel pin in one of the inner bearing retainer (33) tapped holes so that the grease inlet pipes fully correspond.
- End with the NDE shield (6). Fix a dowel pin in one of the inner bearing retainer (53) tapped holes so that the grease inlet pipes fully correspond.
- Lift the rotor slightly and fit the shields in place.

From now on, we recommend checking at every step that the rotor turns freely by hand before continuing to the next instruction.

- Replace the shield fixing screws on DE and NDE shields.
- Insert the fixing screws on the inner bearing retainers (33) and (53). Replace the AZ washers to ensure a perfect seal
- Replace the fan key (8) if appropriate.
- Replace the fan (7).
- Replace the shaft extension screw if necessary.
- Replace the fan cover (13) and reinsert the fixing screws
- Lubricate the DE and NDE bearings, turning the shaft by hand.

Initial grease volume for ball bearings:

- Frame 280-315 2P : DE = 293 cm³ (258g) / NDE = 297 cm³ (261g)
- Frame 280 4P : DE = 217 cm³ (191g) / NDE = 395 cm³ (348g)
- Frame 315 4P : DE = 428 cm³ (377g) / NDE = 395 cm³ (348g)

This initial quantity corresponds to the amount of grease contained inside the bearing as well as the grease located outside the bearing. The weight expressed in grams refers to the original standard grease, the name of which is indicated on the motor nameplate.

The filling of the lubrication channel is not included in this initial volume. It is carried out during the preparation of the bearing housing (5 and 6) at reassembly and consists of filling the channel until clean grease appears at the opposite end.

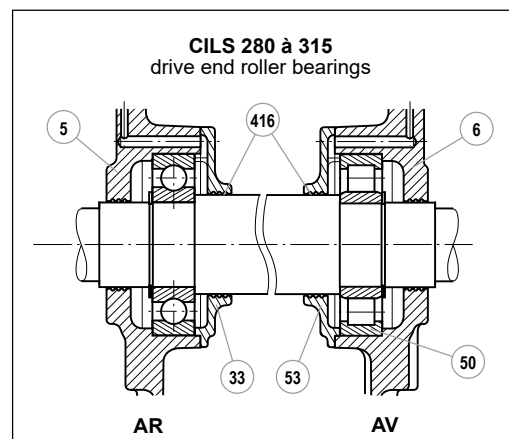
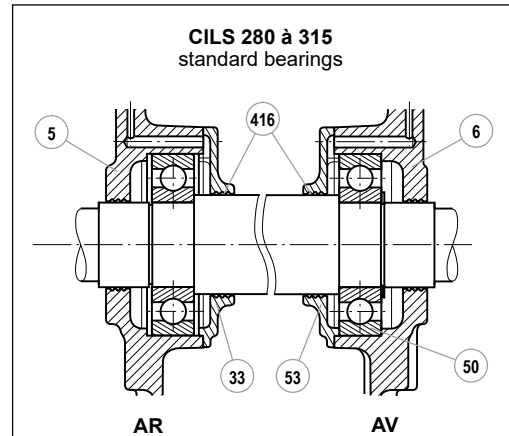

CILS 280 à 315

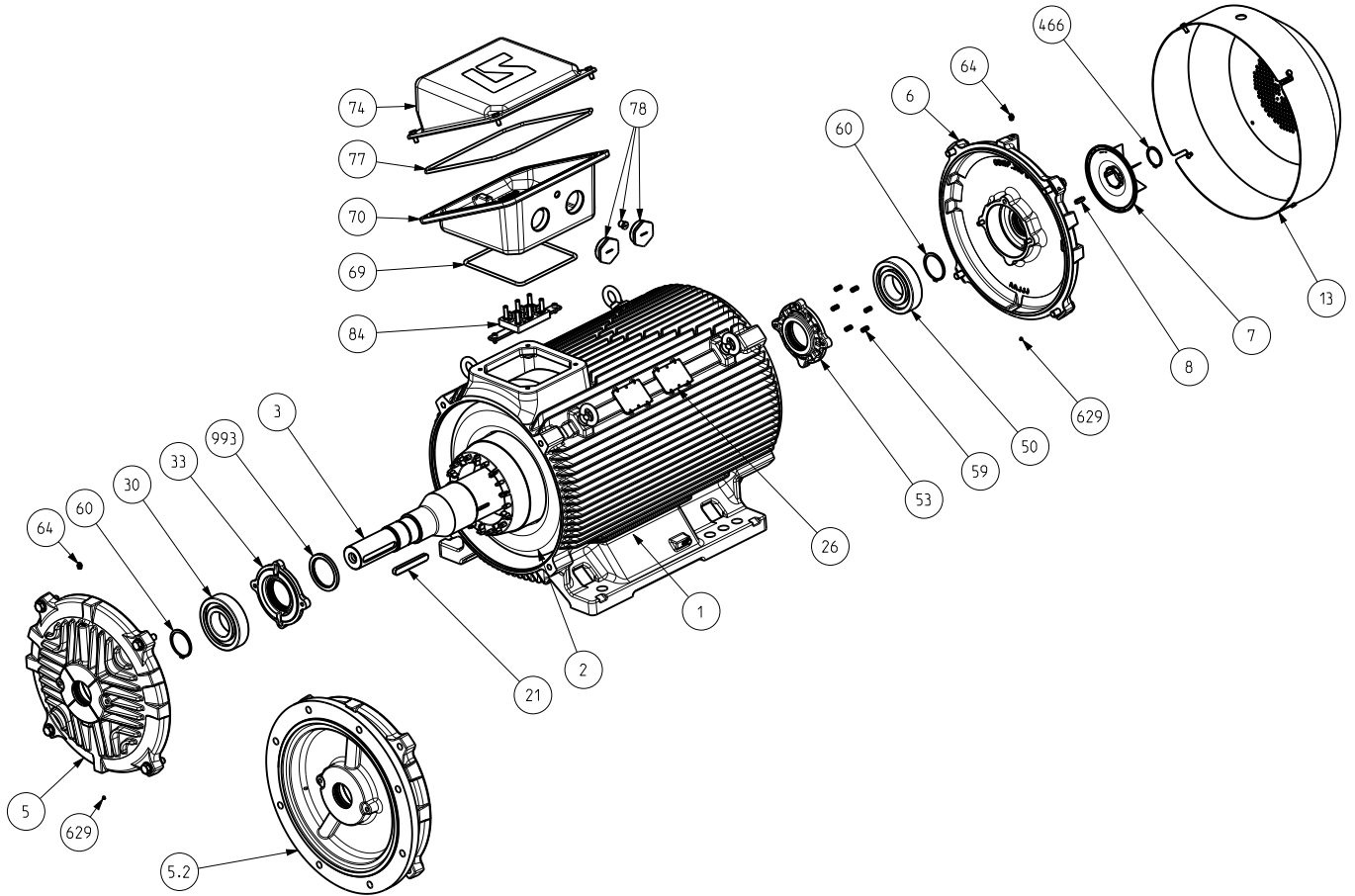

CILS 280 à 315

Ref.	Description	Ref.	Description	Ref.	Description
1	Housing	26	Nameplate	70	Terminal box housing
2	Wound stator	30	Drive end bearing	74	Terminal box cover
3	Rotor	33	Inner drive end bearing retainer	77	Terminal box cover seal
5	Drive end shield	50	Non drive end bearing	78	Cable gland plug
6	Non drive end shield	53	Inner non drive end bearing retainer	84	Terminal board
7	Fan	59	Preloading springs	466	Fan snap ring
8	Fan key	60	Snap ring	629	Drain plug
13	Fan cover	64	Grease nipple	993	shaft grounding ring (optional)
21	Drive end shield shaft extension key	69	Terminal box base seal		

13 - PLSES MOTORS

13.1 - PLSES 225 MG, 250,280 SC/SD/SF/MC/MD/MF motors

13.1.1 - Dismantling

- Remove the screws (27), the grease nipple (64) and its extension (65), then take off the cover (13).
- Pull out the fan (7) using a hub remover or 2 diametrically opposed levers, using the shield (6) for support, then remove the fan key.
- Take out the key (21).
- Unscrew the tie rods (14) then remove them.
- Unscrew the DE bearing retainer (33) and (32) fixing screws (40) and NDE bearing retainer (52) and (53) fixing screws (62), and remove them.
- Unscrew the «Hc» screw of the mobile valve (35) then unscrew the valve using a hook key or a conical bronze drift; unscrew the valve by hand and remove it. The valve holds the seal (39) and its support (386) in place.
- Using a bronze drift, remove the shields (5 and 6) by tapping gently on the shield bosses. Recover the preloading washer (59).
- Remove the circlip (60).
- Remove the rotor (3) from the stator (1) at the drive end, taking care not to touch the winding with the inner bearing retainer.
- Take out the bearings (30) and (50) using a bearing remover, while protecting the end of the shaft end with a washer. Take care not to knock the running surfaces of the shaft.
- The bearings are removed either separately or with the bearing retainers; to avoid damaging the bearing retainers, heat the inner bearing retainer to make it easier to dismantle (the bearing should be discarded).

13.1.2 - Reassembly

- See section 6.1 before reassembly.
- Insert the inner bearing retainer (33) at the rotor drive end and the inner bearing retainer (53) at the non drive end.
- Fit the new bearings on the shaft, see section 6.1 on mounting bearings.
- Mount the circlip (60).
- Insert the rotor (3) in the stator (1) taking every precaution not to knock the winding.
- Screw a rod with the same thread diameter as the screws (40) and (62) into one of the tapped holes of the bearing retainers (33) and (53) to maintain the position of the grease nipple when refitting the shields (5 and 6).
- Position the preloading washer (59) with a small amount of grease at the back of the bearing cage of the NDE shield (6), then remount the NDE shield (6) by positioning it on the stator.
- At the non drive end fit the seal (54) and its support (388), insert the bearing retainer (52) and the locking screws (62) for the bearing retainers (52) and (53).
- At the drive end fit the shield (5) taking care to position the bearing retainer (33) correctly.
- Mount the mobile valve (35) by either screwing it or locking it having carefully mounted the seal (39) and its support (386).
- Mount the shield seals with grease: (54) for the non drive end, (39) for the drive end.
- Mount the outer bearing retainer (32) with the bearing retainer locking screws (40), making sure that the grease drain hole is at the bottom.

- Put the tie rods (14) in place, not forgetting the feet of the protective cover (380), tighten the nuts diagonally without locking them so that the feet of the protective cover can be positioned when it is mounted.
 - Install the fan key.
 - Mount the fan (7) using a drift to bed it in position or by heating the hub of the aluminium fan to approximately 100°C. MAKE SURE it is facing the right way!
 - Check that the motor turns freely by hand and that there is no axial play.
 - Replace the protective cover (13) and fix it with the screws (27), replace the grease nipple (64) and its extension (65).
 - Tighten the rod nuts (14), always diagonally, up to the torque recommended in section 6.1.
 - Fill with new grease: the quantity is indicated in the table below.
- Turn the shaft by hand during greasing.
- Replace the key (21).

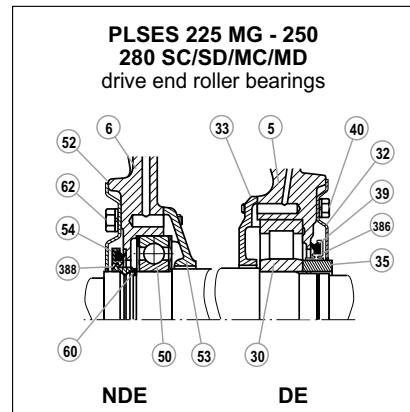
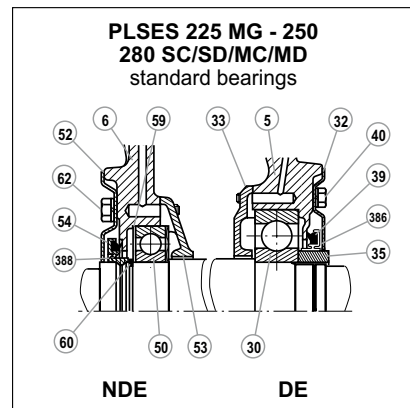

Bearing	g	cm ³
6314	105	118
6315	140	159
6317 or NU317	180	205
6318 or NU318	220	250

(Weight valid for POLYREX EM103 grease with immaculately clean grease track + bearing seat + drain holes).

PLSES 225 MG, 250, 280 SC/SD/SF/MC/MD/MF

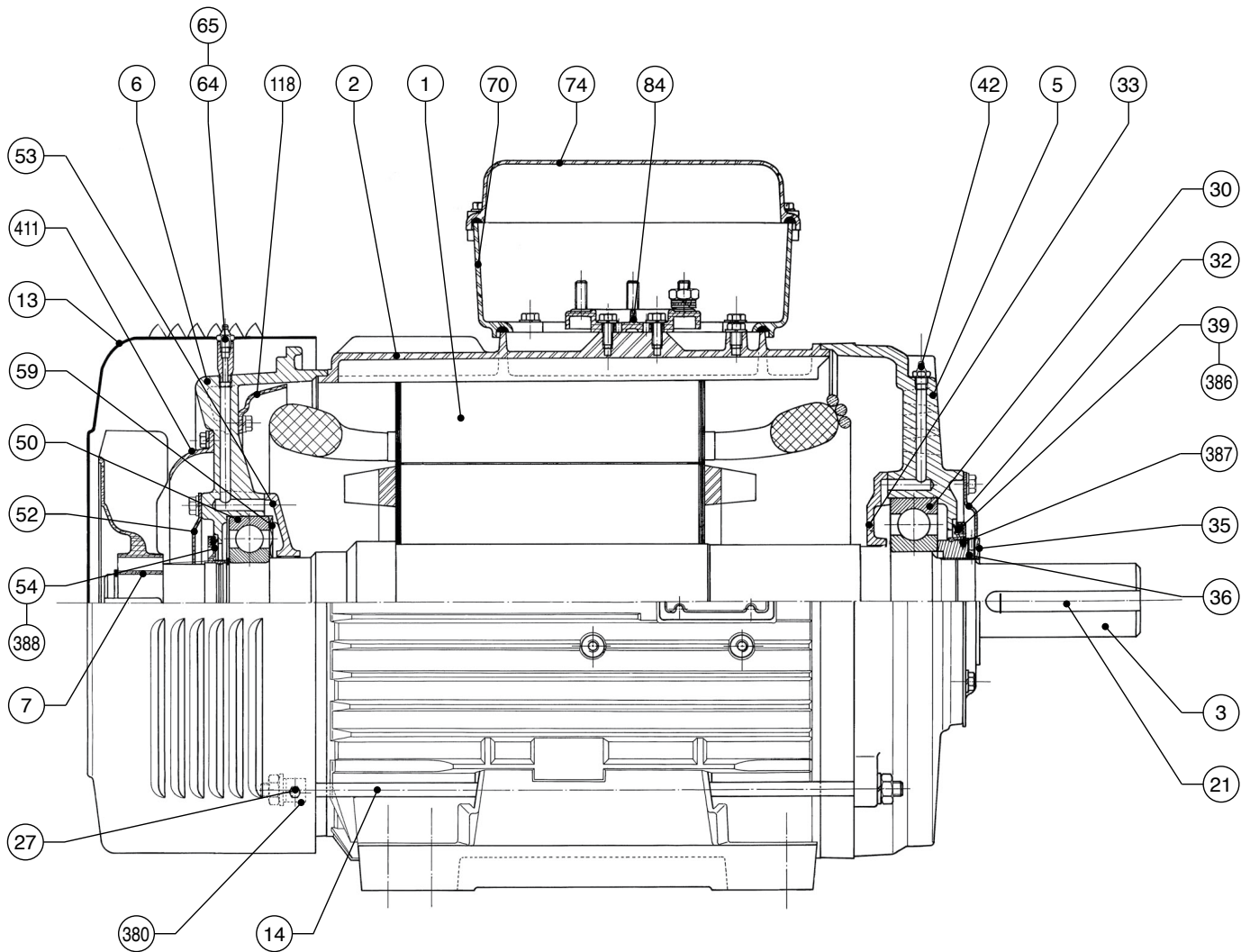

PLSES 225 MG, 250, 280 SC/SD/SF/MC/MD/MF

Ref.	Description	Ref.	Description	Ref.	Description
1	Wound stator	32	Outer drive end bearing retainer	65	Extension for grease nipple
2	Frame	33	Inner drive end bearing retainer	70	Terminal box
3	Rotor	35	Drive end mobile grease valve	74	Terminal box lid
5	Drive end shield	39	Drive end seal	84	Terminal block
6	Non drive end shield	42	Grease nipple	118	Internal deflector
7	Fan	50	Non drive end bearing	380	Protective cover feet
13	Fan cover	52	Outer non drive end bearing retainer	386	Drive end seal support
14	Tie rods	53	Inner non drive end bearing retainer	388	Non drive end seal support
21	Key	54	Non drive end seal	411	External deflector
27	Fan cover screw	59	Preloading (wavy) washer		
30	Drive end bearing	64	Grease nipple		

13.2 - PLSES 280 MG /SG, 315 motors

13.2.1 - Dismantling

- Remove the cover (13) once the screws (27) and grease nipple (64) have been removed.
- Pull out the fan (7) using a hub remover or 2 diametrically opposed levers, using the shield (6) for support; for an aluminium fan, heat the hub to approximately 100°C before removing it.
- Take out the key (21).
- Unscrew the mounting screws (14) then remove them.
- Unscrew the screws (32) of the inner DE bearing retainer (33) and the screws (52) of the inner NDE bearing retainer (53).
- Remove the front (39) and rear (54) seals.
- Using a bronze drift, remove the shields (5 and 6) by tapping gently on the shield bosses.
- Check that the bearing retainer (53) is smaller in diameter than the stator, otherwise remove the bearing (50) as per the following instructions.
- Remove the rotor (3) from the stator (1) at the drive end taking care not to touch the winding with the inner bearing retainer if there is no internal turbine. Remove the circlip (35) and take out the bearings (30) and (50) using a bearing remover, while protecting the end of the shaft extension with a washer. Avoid knocking the running surfaces of the shaft.
- The bearings are removed either separately or with the bearing retainers (33 and 53); to avoid damaging the bearing retainers, heat the inner bearing ring (the bearing should be discarded).
- Recover the preloading washer or springs (59) from the bearing retainer (53).

13.2.2 - Reassembly

- See section 6.1 before reassembly.
- Insert the inner bearing retainer (33) at the rotor drive end and the inner bearing retainer (53) at the non drive end, not forgetting to insert the preloading springs (59) with a little grease.
- Mount the new bearings (30 and 50) on the shaft, see section 6.1 Mounting the bearings, and the circlip (35).
- Insert the rotor (3) in the stator (1) taking every precaution not to knock the winding.
- Check that the preloading springs (59) are correctly installed.
- Mount the NDE shield (6) by positioning it on the stator.
- Mount the DE shield (5) by positioning it on the stator.
- Mount the shield seals with grease: (54) for the non drive end, (39) for the drive end.
- Refit the inner DE (33) and NDE (53) bearing retainers with the locking screws (32) and (52).

- Put the tie rods (14) and the feet of the protective cover (380) in place, tighten the nuts diagonally without locking them so that the feet of the protective cover can be positioned when it is mounted.
- Install the fan key.
- Mount the fan (7) using a drift to bed it in position or by heating the hub of the aluminium fan to approximately 100°C. MAKE SURE it is facing the right way!
- Check that the motor turns freely by hand and that there is no axial play.
- Refit the cover (13), fixing it using the screws (27), and refit the grease nipple (64).
- Fill with new grease: the quantity is indicated in the table below. Turn the shaft by hand during greasing.
- Tighten the nuts (14), always diagonally, up to the torque recommended in section 6.1.
- Replace the key (21).

PLSES 280 MG - 315
Standard bearings

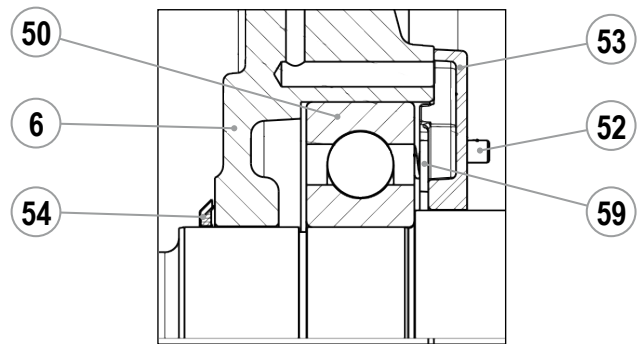

NDE

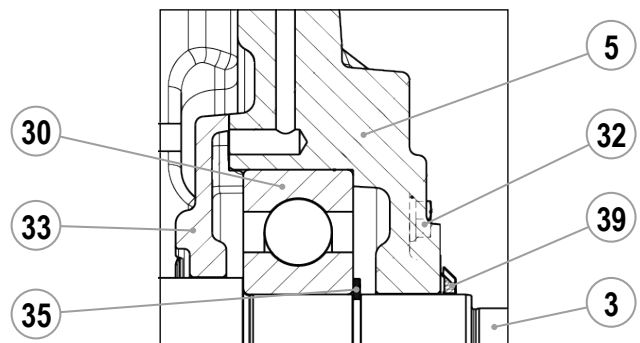

DE

Bearing	g	cm3
6316	211	240
6320	334	380
NU320	385	438
6317	236	268
6219	215	244
6224	244	277

(Weight valid for POLYREX EM103 grease with immaculately clean grease track + bearing seat + drain holes).

PLSES 280 MG/SG, 315

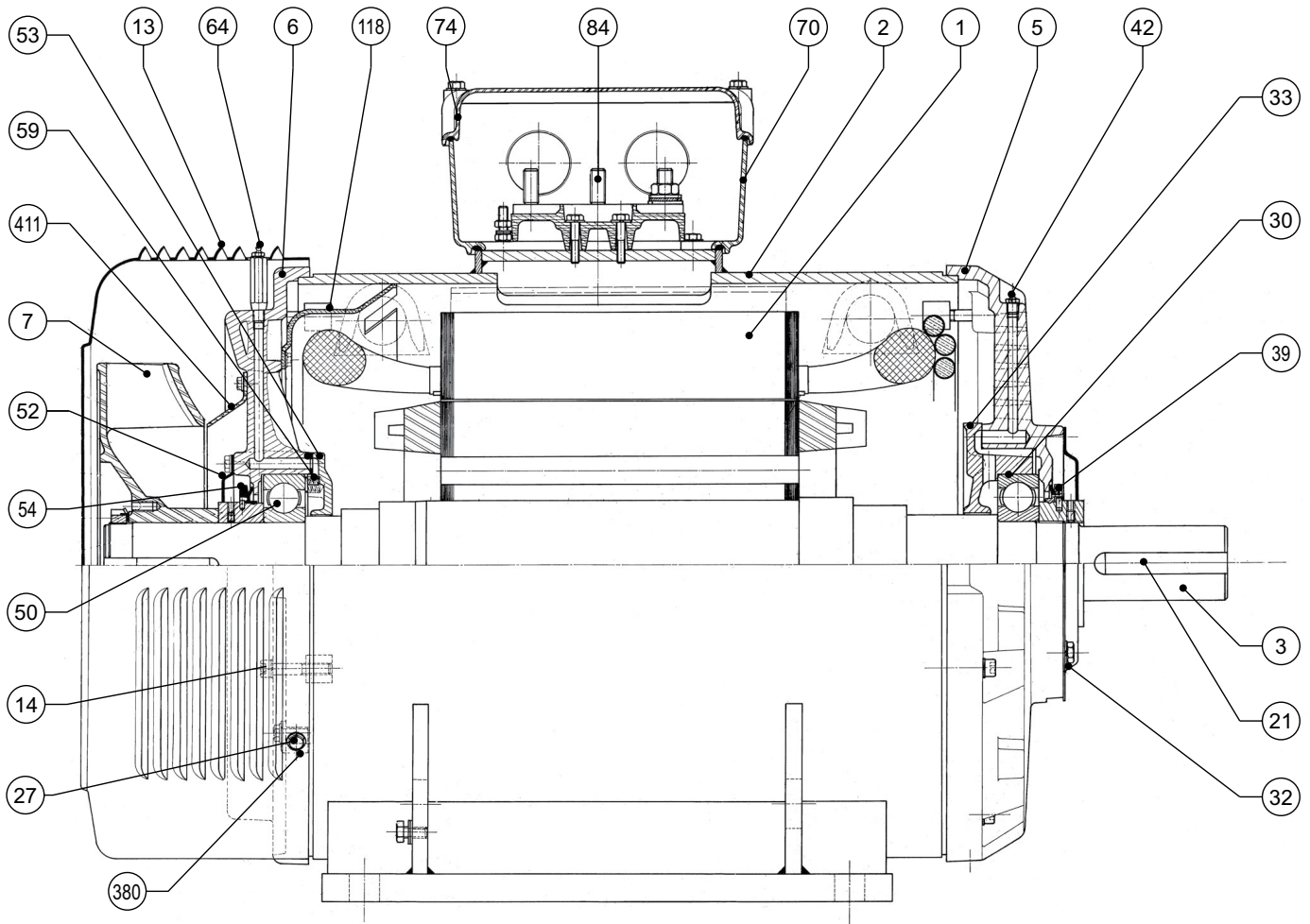

PLSES 280 MG/SG, 315

Ref.	Description	Ref.	Description	Ref.	Description
1	Wound stator	32	Drive end bearing retainer fixing screw	70	Terminal box
2	Frame	33	Inner drive end bearing retainer	74	Terminal box lid
3	Rotor	35	Drive end circlip	84	Terminal block
5	Drive end shield	39	Drive end seal	118	Internal deflector
6	Non drive end shield	42	Drive end grease nipple	380	Protective cover feet
7	Fan	50	Non drive end bearing	411	External deflector
13	Fan cover	52	Non-drive end bearing retainer fixing screw		
14	Tie rods	53	Inner non drive end bearing retainer		
21	Key	54	Non drive end seal		
27	Fan cover screw	59	Preloading (wavy) washer		
30	Drive end bearing	64	Non-drive end grease nipple		

13.3 - PLSES 315 MGU to VLGU, PLSES 355 motors

13.3.1 - Dismantling the NDE shield

- Remove the fixing screws (27) and then take off the cover (13).
- Remove the shaft extension screw if necessary.
- Take out the fan (7).
- Remove the fixing screws from the inner NDE bearing retainer (53).
- Remove the fixing screws (273) from the NDE shield (6).
- Remove the fan key if appropriate.
- Using two levers or a flexible hammer, disengage the NDE shield (6) taking care not to place it aslant. Remove the shield by sliding it along the shaft.
- Put the dismantled components to one side and retrieve the preloading springs (256), which should be replaced in their housing.

13.3.2 - Dismantling the DE shield

- Dismantle the DE shield without removing the rotor (3). To do this:
- Remove the fixing screws (270) from the DE shield (5).
- Remove the fixing screws (40) from the DE internal cover (33).
- Take out the key (21).
- Using two levers or a flexible hammer, disengage the DE shield (5) taking care not to place it aslant.
- Remove the shield by sliding it along the shaft.

13.3.3 - Changing the antifriction bearings

- Using an appropriate lifting tool, take out the rotor without knocking the winding.
- Remove the DE (38) and NDE (60) circlips.
- Remove the bearings (30) and (50) with an appropriate tool, protecting the end of the shaft extension. Do not knock the running surfaces of the shaft.
- Change the bearings in accordance with the instructions described in the General information in section 6 (shrinkfitting only).

IMPORTANT : Before undertaking any of these procedures, read the «**CHECKS BEFORE REASSEMBLY**» section.

13.3.4 - Reassembly

- Mount the DE bearing (30) on the rotor shaft (take care not to forget the inner bearing retainer (33) and the circlip (38)!), and also the NDE bearing (50) if and only if the stator inner \varnothing allows the inner NDE bearing retainer (53) to pass through, refit the circlip (60), refit the preloading springs in their housing in the inner NDE bearing retainer (53).
- Insert the rotor into the stator taking care not to knock the winding. Install the NDE bearing if this has not already been done.
- Fill the decompression grooves (416) located in the shaftway and the grease inlet pipes with grease.
- Present the shields, grease nipples facing upwards. Begin with the DE shield (5). Fix a dowel pin in one of the inner bearing retainer (33) tapped holes **so that the grease inlet pipes fully correspond.**
- End with the NDE shield (6). Fix a dowel pin in one of the inner bearing retainer (53) tapped holes **so that the grease inlet pipes fully correspond.**
- Lift the rotor slightly and fit the shields in place.

From now on, we recommend checking at every step that the rotor turns freely by hand before continuing to the next instruction.

- Replace the shield fixing screws (270) and (273).
- Insert the fixing screws on the inner bearing retainers (33) and (53). Replace the AZ washers to ensure a perfect seal.
- Replace the fan key if appropriate.
- Replace the fan (7).
- Replace the shaft extension screw if necessary.
- Replace the cover (13) and reinsert the fixing screws (27).
- Lubricate the DE and NDE antifriction bearings, turning the shaft by hand.

Initial grease volume for ball bearings:

- Frame 315-355 2P : DE = 268 cm³ (236g) / NDE = 268 cm³ (236g)
- Frame 315 4P : DE = 613 cm³ (539g) / NDE = 268 cm³ (236g)
- Frame 355 4P : DE = 783 cm³ (689g) / NDE = 268 cm³ (236g)

This initial quantity corresponds to the amount of grease contained inside the bearing as well as the grease located outside the bearing. The weight expressed in grams refers to the original standard grease, the name of which is indicated on the motor nameplate.

The filling of the lubrication channel is not included in this initial volume. It is carried out during the preparation of the bearing housing (5 and 6) at reassembly and consists of filling the channel until clean grease appears at the opposite end.

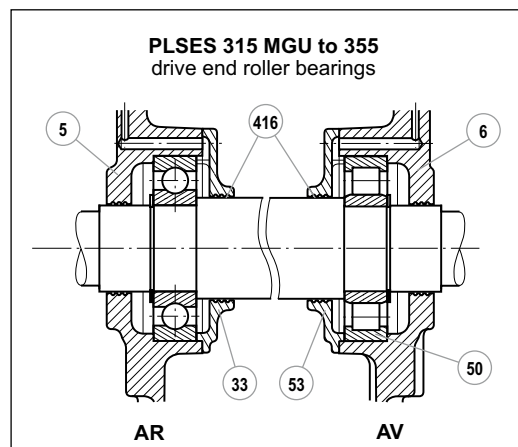
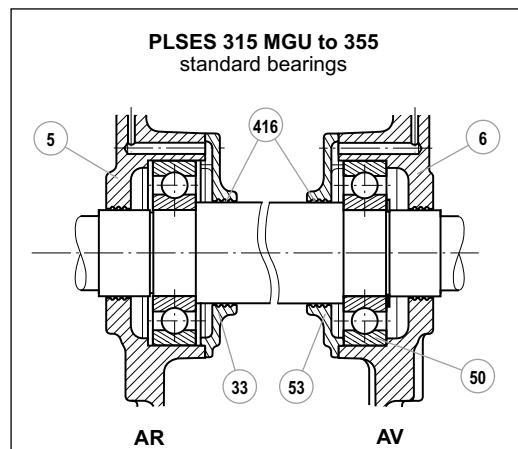

PLSES 315 LG/MGU to VLGU, PLSES 355

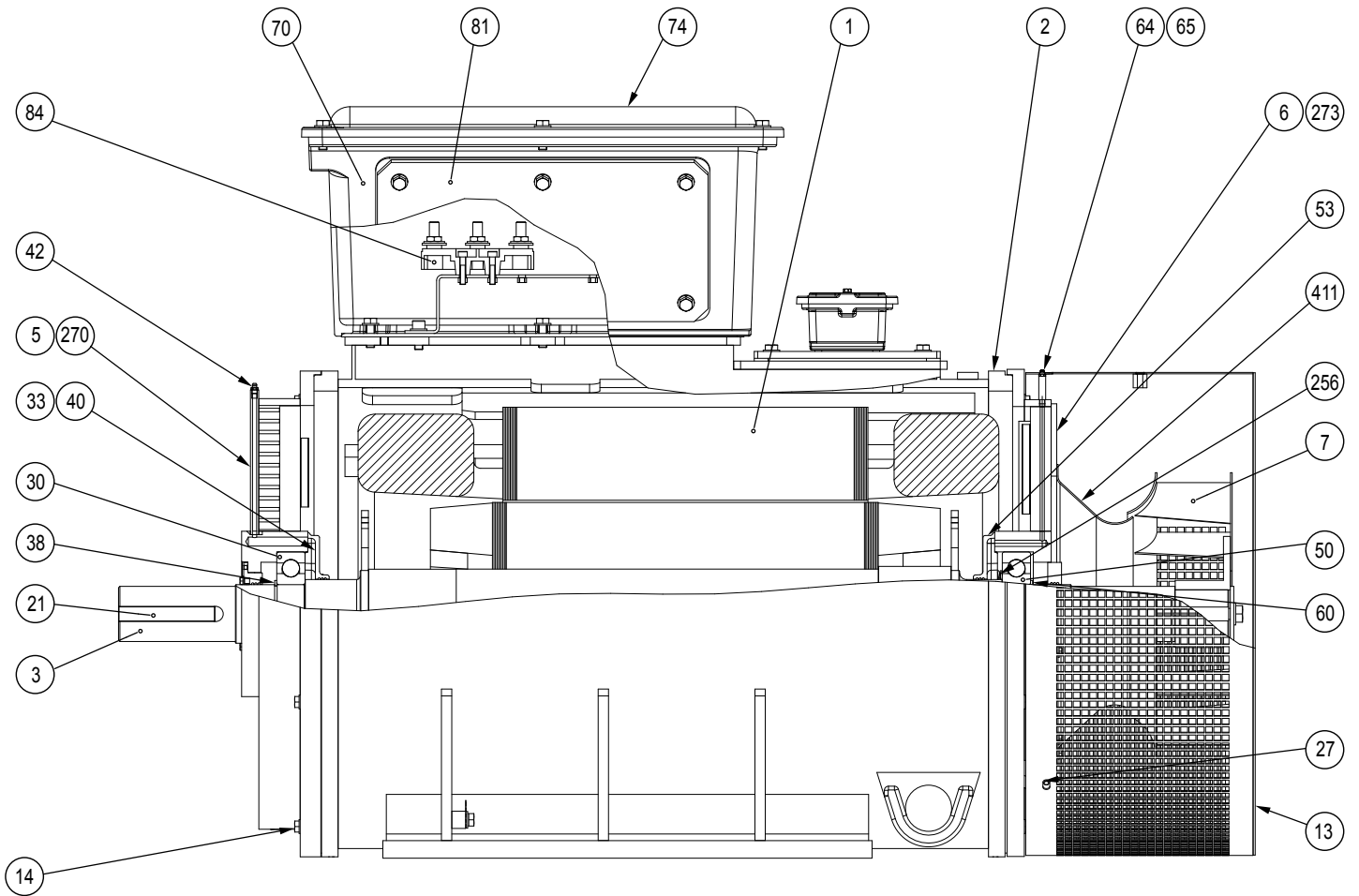

PLSES 315 LG/MGU à VLGU, PLSES 355

Ref.	Description	Ref.	Description	Ref.	Description
1	Wound stator	30	Drive end bearing	70	Terminal box
2	Frame	33	Inner drive end bearing retainer	74	Terminal box lid
3	Rotor	38	Circlip	81	Cable gland support plate
5	Drive end shield	40	Screw	84	Terminal block
6	Non drive end shield	42	Grease nipple	256	Preloading spring
7	Fan	50	Non drive end bearing	270	Drive end shield fixing screw
13	Fan cover	53	Inner non drive end bearing retainer	273	Non drive end shield fixing screw
14	Tie rods	60	Circlip	411	External deflector
21	Key	64	Grease nipple	416	Bearing retainer screw
27	Fan cover screw	65	Extension for grease nipple		

Nidec
All for dreams

LEROY-SOMERTM



Moteurs Leroy-Somer
Headquarter: Boulevard Marcellin Leroy - CS 10015
16915 ANGOULÈME Cedex 9
France

Limited company with capital of 32,239,235 €
RCS Angoulême 338 567 258
www.leroy-somer.com