

DIGISTART STV 1312

Electronic soft starter

Installation and maintenance

Electronic soft starter DIGISTART STV 1312

SAFETY AND OPERATING INSTRUCTIONS CONCERNING soft starter (According to low voltage directive 73/23/CEE modified by 93/68/CEE)

 • Throughout the manual, this symbol warns against consequences which may arise from inappropriate use of the soft starter, since electrical risks may lead to material or physical damage as well as constitute a fire hazard.

1 - General

According to their degree of protection, soft starters can during operation comprise bare live parts, sometimes moving or rotating, as well as hot surfaces.

Unjustified removal of protections, incorrect use, faulty installation or inappropriate operation could represent a serious risk to personnel and machinery. Refer to the manual for additional information.

Any work related to transportation, installation, commissioning and maintenance must be carried out by experienced and qualified personnel (see CEI 364 or CENELEC HD 384, or DIN VDE 0100 and national specifications for installation and accident prevention).

According to these basic safety instructions, qualified personnel means persons competent to install, mount, commission and operate the concerned product and possessing the relevant qualifications.

2 - Use

Soft starters are components designed for integration within an installation or an electrical machine.

When integrated in a machine, commissioning is forbidden as long as conformity with Directive 89/392/CEE (Machinery Directive) has not been checked. It is also necessary to comply with standard EN 60204, which especially stipulates that electrical actuators (which include soft starters) cannot be regarded as circuit-breaking devices and by no means as isolating switches.

Commissioning can take place only if the requirements of the Electromagnetic Compatibility Directive (89/336/CEE, modified by 92/31/CEE) are fulfilled.

Soft starters fulfil the requirements of the Low Voltage Directive 73/23/CEE, modified by 93/68/CEE. The harmonized standards of the DIN VDE 0160 series in connection with standard VDE 0660, part 500 and EN 60146/VDE 0558 are also applicable.

Technical specifications and instructions concerning connection conditions specified on the rating plate and in the supplied documentation must absolutely be respected without fail.

3 - Transportation, storage

All instructions concerning transportation, storage and correct handling must be respected.

Climatic conditions specified in the technical manual must be respected.

4 - Installation

Installation and cooling of equipment must comply with the specifications stated in the manual supplied with the product.

Soft starters must be protected against excessive stress. More particularly, avoid any damage to parts and/or modification of insulation distances between components during transportation and handling. Avoid touching electronic components and contact parts.

Soft starters include parts which are sensitive to electrostatic stress and can easily be damaged if handled incorrectly. Electrical components must not be exposed to mechanical damage or destruction (possible risks to health !).

5 - Electrical connection

When work is carried out on the powered-up soft starters, national specifications for accident prevention must be respected.

Electrical installation must conform with the appropriate specifications (for instance wire section, protection with circuit-breaking fuse, connection of protective conductor). Refer to the documentation for more detailed information.

Instructions for an installation complying with electromagnetic compatibility requirements (such as screening, earthing, presence of filters and correct mounting of cables and conductors) are outlined in the documentation supplied with the soft starter. These instructions must always be respected even if the speed controller has the CE mark. The manufacturer of the installation or of the machine is responsible for the conformity with the limits given in the EMC legislation.

6 - Operation

Installations incorporating soft starters must be fitted with additional protection and monitoring equipments specified in the current relevant safety regulations, such as law on electrical equipment, specifications for accident prevention, etc... Modifications to soft starters using control software are allowed.

After the soft starter has been powered down, active parts of the equipment and live power connections must not be touched immediately as the capacitors may still be charged. In view of this, refer to the warnings marked on the soft starters.

During operation, all doors and protections must remain closed.

7 - Service and maintenance

Refer to the manufacturer's documentation.

This document must be forwarded to the end user.

Electronic soft starter DIGISTART STV 1312

CONTENTS

	Pages
1 - GENERAL INFORMATION	
1.1 - General operating principle.....	6 - 7
1.2 - General designation of the DIGISTART.....	8
1.3 - Main characteristics.....	8
1.4 - Dimensions and weight.....	9 à 11
2 - MECHANICAL INSTALLATION	
2.1 - Inspection on arrival.....	12
2.2 - Unpacking.....	12
2.3 - Installation precautions.....	12
2.4 - Mounting.....	12
3 - CONNECTIONS	
3.1 - General recommendations.....	13
3.2 - Terminal blocks.....	13
3.3 - Power connections.....	13 - 14
3.4 - Control electronics supply connections.....	14
3.5 - Remote control connections.....	14
3.6 - Standard connections.....	15
3.7 - Special connections.....	16
3.8 - Radio-frequency interference.....	17
4 - COMMISSIONING	
4.1 - Setting procedure.....	18
4.2 - Pushbuttons/display presentation.....	18
4.3 - Status indication.....	19
4.4 - Switching on control electronics.....	19
4.5 - Programming.....	19 à 23
4.6 - Switching on power stack.....	24
4.7 - Starting.....	24
4.8 - Settings lock.....	24
4.9 - Reverting to factory settings.....	24
5 - FAULTS/DIAGNOSTICS	
5.1 - Possible causes of malfunction.....	25
5.2 - Trip indication.....	25
5.3 - List of trip codes and possible causes.....	26
6 - MAINTENANCE	
6.1 - Care.....	27
6.2 - Spare parts list	27
7 - SUMMARY OF SETTINGS.....	29

Electronic soft starter DIGISTART STV 1312

1 - GENERAL INFORMATION

1.1 - General operating principle

The DIGISTART is a multi-function electronic system controlled by a 8 bit microcontroller designed for use with **all three phase cage induction motors**.

It ensures progressive starting with :

- Reduced starting current,
- Smooth and steady acceleration obtained by monitoring the current absorbed by the motor

After start-up, the DIGISTART provides the **additional features** described below.

1.1.1 - Functional block diagram

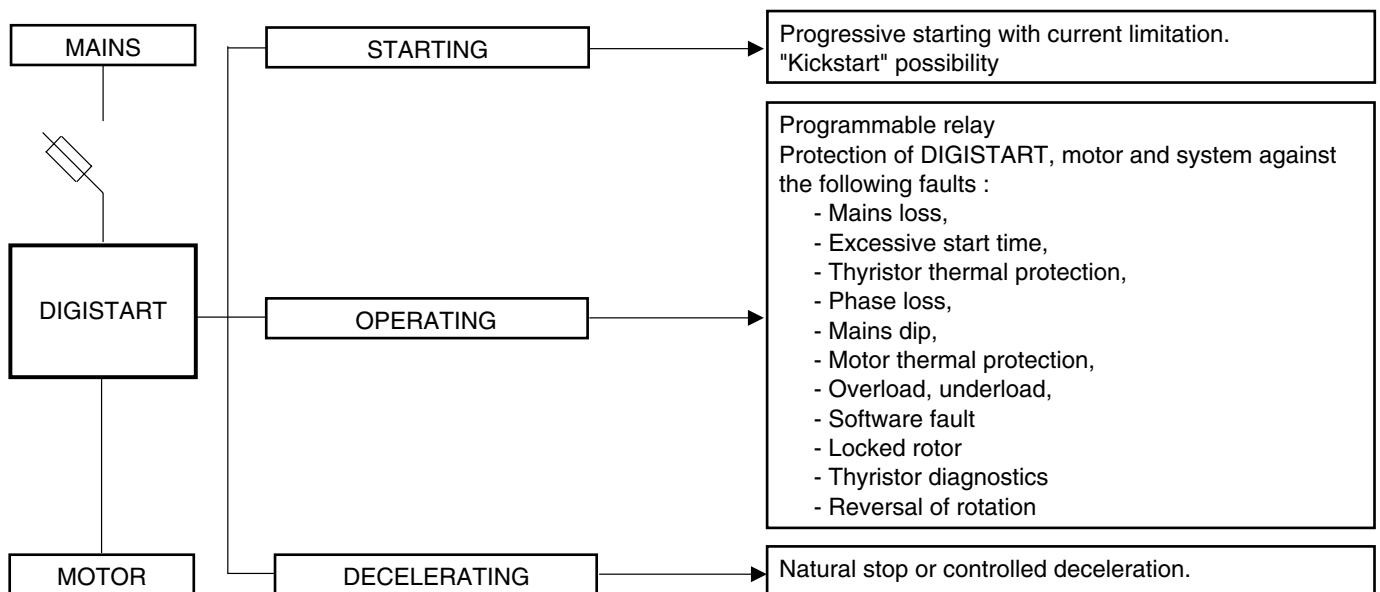

1.1.2 - Description

The DIGISTART STV 1312 comprises :

- a power stack,
- a power board,
- a control board.

The **power stack** has the following components :

- 6 power thyristors mounted on a naturally cooled heatsink,
- the connection terminals.

The **power board** comprises :

- the electronic supply circuits,
- the gate drive control,
- mains measurement,
- control board interface.

The **control board** comprises :

- the remote control connection terminals
- the output relays,
- the microcontroller and its peripherals,
- the electronic regulation circuits,
- 3 setting pushbuttons,
- 1 seven segment display.

Electronic soft starter DIGISTART STV 1312

1.1.3 - Operating diagram

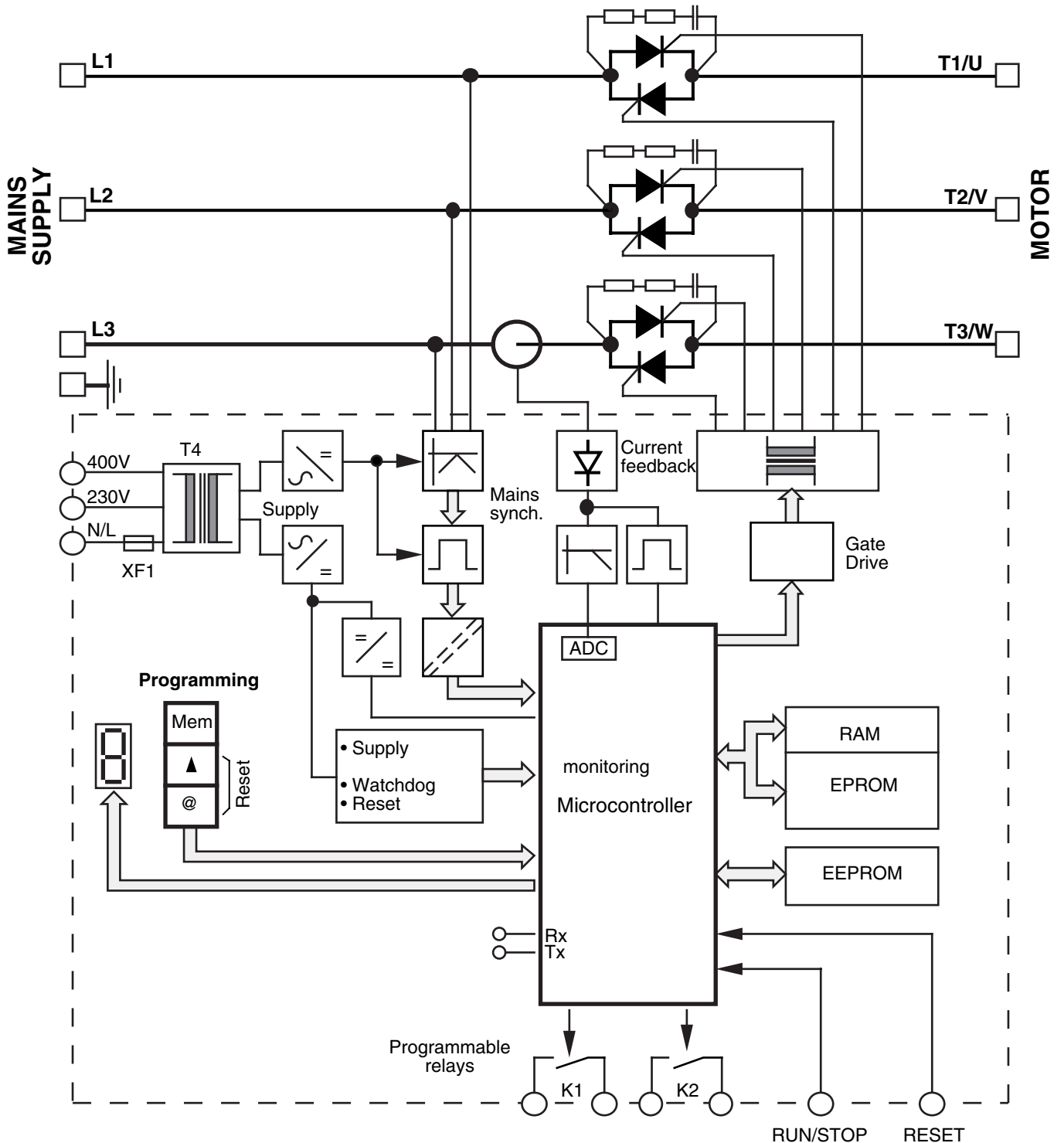

1.1.4 - Setting and operating mode

STV 1312 settings are made by a 3 pushbutton keypad. Its operation is made easy by a 7 segment display of parameters and their values.

Electronic soft starter DIGISTART STV 1312

1.2 - General designation of the DIGISTART

Example : STV 1312 - 14 10

- STV 1312 = DIGISTART
- 14 = Mains voltage code, with
 - 14 : 208 V to 500 V
 - 16 : 500 V to 690 V

- 10 = Current rating code, with
 - 06 = 6A
 - 10 = 10A
 -
 - 44 = 44A

1.3 - Main characteristics

The DIGISTART STV 1312 has an ingress protection of IP 20.

It must be mounted into a cabinet free of dust and condensation.

RATING	6	10	16	22	30	44
Power stack supply						
Voltage	2 possibilities : - Code 14: 208V to 480V (-15% +10%) three-phase - Code 16: 500V to 690V (-15% +10%) three-phase					
Frequency	Self-adjusting 50/60 Hz \pm 5%					
Control supply						
Voltage	230V (-20% +15%) or 400V (-15% +10%) single phase					
Frequency	Self-adjusting 50/60 Hz \pm 5%					
Consumption	19 VA					
Operating conditions						
Rated motor current In	6A	10A	16A	22A	30A	44A
Maximum N° of starts per hour at 3 In	15	15	10	10	10	10
Maximum start time at 3 In	30 s	30 s	30 s	30 s	30 s	30 s
The DIGISTART rating can be inferior to the rated motor current, provided that the operating conditions are less severe than those given above						
Protection rating	IP 20					
Electromagnetic compatibility and susceptibility	Immunity : complies EN 50082-1 / EN 50082-2 (see § 3.8). Conducted and radiated emissions : complies EN 55011 (see § 3.8).					
Ambient temperature	from -0°C to +40°C.					
Maximum temperature	60°C Derating of 1.2% per °C above 40°C					
Storage temperature	from -20°C to +60°C					
Altitude	Less than 1000 metres Derate current by 0.5% for each 100 m above 1000 m					
Relative humidity (non condensing)	In accordance with IEC 68-2-3 and IEC 68-2-30					
Shock	In accordance with IEC 68-2-27					
Vibration	In accordance with IEC 68-2-6					

Electronic soft starter DIGISTART STV 1312

1.4 - Dimensions and weight

1.4.1 - DIGISTART dimensions

- STV 1312 : 6, 10.

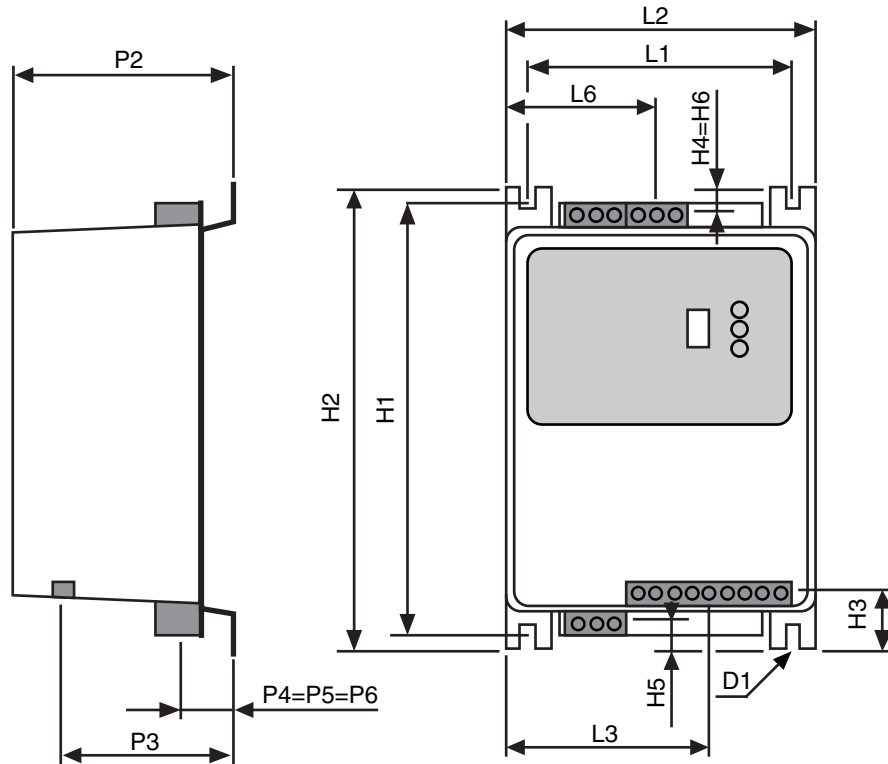

- STV 1312 : 16, 22.

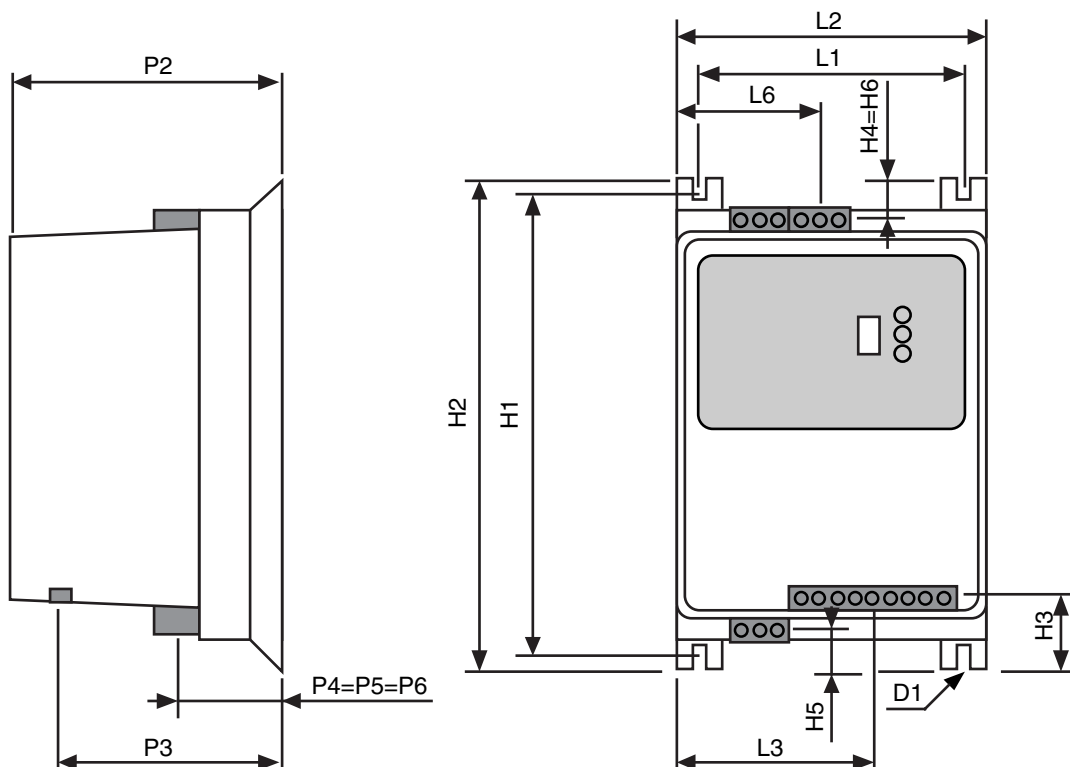

Electronic soft starter DIGISTART STV 1312

• STV 1312 : 30, 44.

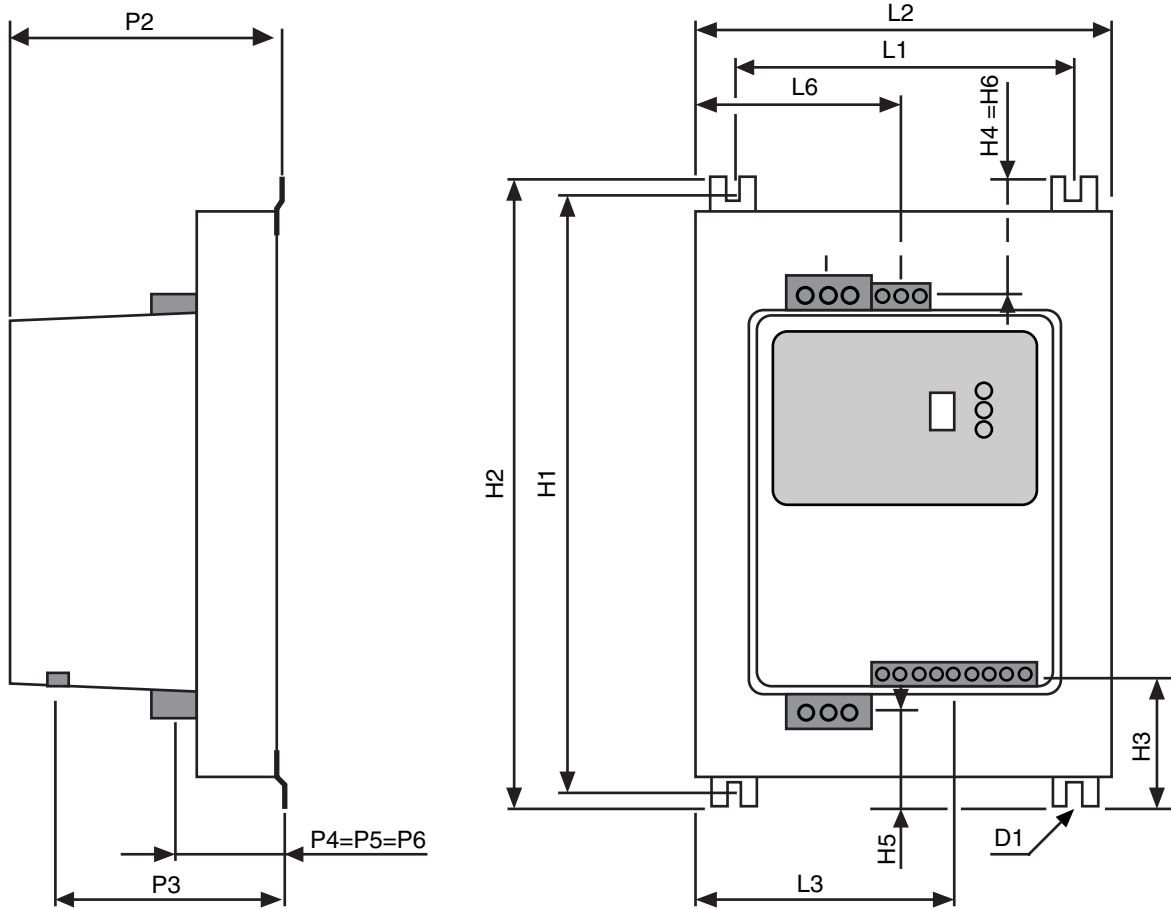

Electronic soft starter DIGISTART STV 1312

1.4.2 - Table of dimensions (mm) and weight

Rating		STV 1312	6	10	16	22	30	44
Mounting	H1		253	253	253	253	336	336
	L1		130	130	130	130	169	169
	D1		6.5	6.5	6.5	6.5	6.5	6.5
Overall	H2		273	273	273	273	356	356
	P2		116	116	153	153	138	138
	L2		155	155	155	155	209	209
Control terminal block	H3		55	55	55	55	96	96
	P3		100	100	130	130	120	120
	L3		95	95	95	95	120	120
Mains Power supply connection L1. L2. L3	H4		25	25	30	30	70	70
	P4		30	30	60	60	50	50
	E4		45	45	45	45	70	70
	max cross-section		4 mm ²	4 mm ²	4 mm ²	4 mm ²	10 mm ²	10 mm ²
Motor Power supply Connection T1/U. T2/V. T3/W	H5		25	25	30	30	70	70
	P5		30	30	60	60	50	50
	E5		45	45	45	45	60	60
	max cross-section		4 mm ²	4 mm ²	4 mm ²	4 mm ²	10 mm ²	10 mm ²
Control electronic Supply Connections N/L-230V-400V	H6		25	25	30	30	70	70
	P6		30	30	60	60	50	50
	L6		75	75	75	75	105	105
	max cross-section		4 mm ²	4 mm ²	4 mm ²	4 mm ²	4 mm ²	4 mm ²
Weight	(kg)		2.2	2.2	4.3	4.3	4.8	4.8

Electronic soft starter DIGISTART STV 1312

2 - MECHANICAL INSTALLATION



• The owner or user is responsible for making sure that installation, operation and service of the soft starter and its options comply with legislation relating to the safety of machinery and personnel, and with current regulations of the concerned country.

• The soft starter must be installed in an environment free from conducting dust, fumes, corrosive fluids and gases and from condensation (for instance class 2 according to UL 840 and CEI 664.1).

The soft starter must not be installed in a hazardous area unless it is enclosed in a specially adapted cubicle. In this case the installation must be certified.

• Within atmospheres subject to condensation, it is necessary to install a heating system which functions when the soft starter is not in use and is disconnected when the controller is operating. Ideally this heating system should be controlled automatically.

• The housing of the STV 1312 is not fireproof : therefore it might be necessary to use a fireproof cubicle.

2.1 - Inspection on arrival

Before installation, check :

- that the equipment has not been damaged in transit (if damage has occurred, inform the carrier accordingly).
- that the mains supply voltage is compatible with the DIGISTART.

2.2 - Unpacking

During unpacking, the DIGISTART should never be manoeuvred by means of any items of circuitry, terminal blocks or wiring.

2.3 - Installation precautions

The DIGISTART is wall mounted. Install in a vertical position and observe the following precautions :

- When the DIGISTART is installed in a cabinet, particular care should be taken to ensure the airflow necessary for cooling. To achieve this, a sufficient space should be left around the DIGISTART of 10 cm above and below.

- Before fixing the DIGISTART in place, ensure that the position selected is protected against dust, corrosive vapour, water splashes, vibration, direct sunlight.

- The installation should be carried out with care. Distortion or severe jolting could damage parts of the main circuit.

- Leave sufficient access around the DIGISTART to facilitate connection.

- When the DIGISTART is installed in a cabinet, ensure that ventilation is sufficient to remove excess heat.

DIGISTART Rating	6	10	16	22	30	44
Losses (W)	20	30	40	70	90	130

- In cases where several DIGISTART are used, these should be mounted side by side to prevent overheating, with sufficient space between each DIGISTART.

2.4 - Mounting

The 30 and 44 rating DIGISTART are delivered with a set of mounting feet.

Slide the feet into the grooves provided on the heatsink. It may be necessary to punch the heatsink to hold the feet in place and help handling during DIGISTART mounting.

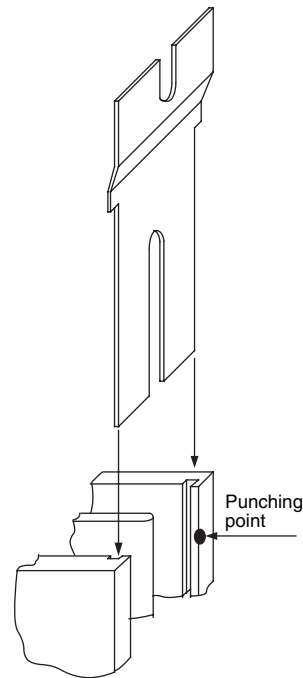

Electronic soft starter DIGISTART STV 1312

3 - CONNECTIONS

⚠ • All connection works must be carried out according to the current legislation of the concerned country. This includes earthing or grounding in order to make sure that no directly accessible part of the controller can remain at mains potential or any other voltage that may be hazardous.

• The voltages existing on the wires or connections to the mains, the motor, the braking resistor or the filter, may cause fatal electric shocks. Avoid contact in any case.

• The soft starter must be supplied through a circuit-breaking device in order to disconnect it safely.

• The soft starter power supply must be protected against overloads and short-circuits.

• The stop function of the soft starter does not protect against the high voltages existing on the terminal blocks.

• After the power supply has been cut off, wait for 1mn before removing protective cover.

• Make sure that voltage of DC bus is lower than 40V before any work is carried out.

• Check that voltage and current of soft starter, motor and mains are compatible.

3.1 - General recommendations

- Do not connect any power capacitor between the DIGISTART output and the motor.

- Use twisted wires for control power supply.

- Use RC circuits on the coils of the relays or contactors controlled by the DIGISTART outputs.

- Avoid running the control wires and power cables in the same conduit.

- The connections to the control board must be made using screened stranded cable. The screen must be connected to the earth terminal of the DIGISTART (at one end only).

WARNING ! :

The wires and cables connected to the control and power terminals of the DIGISTART must be able to withstand 105°C.

3.2 - Terminal blocks

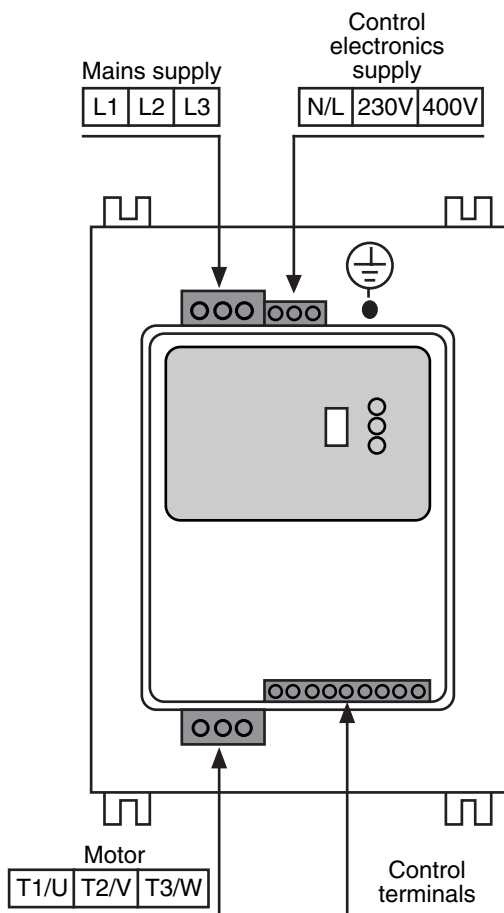

3.3 - Power connections

⚠ • The user is responsible for connecting and protecting the soft starter according to current legislation and regulations of the concerned country. This is particularly important for the size of cables, the type and size of fuses, the connection to earth or ground, the power cut-out, the fault clearance, the insulation and protection against overcurrent.

• The following tables are given as an indication, and can by no means serve as a substitute for current standards.

3.3.1 - Power terminals

a) Description

Power connections comprise : an input terminal block ; an output terminal block and an earth connection.

Reference	Designation	Function
L1, L2, L3	DIGISTART input	Three phase power supply according to characteristics (section 1.3)
T1/U, T2/V, T3/W	DIGISTART output	Motor (s) supply
⊥	Earth	DIGISTART casing earth connection

b) Cable sizes depending on DIGISTART rating

Rating	max. cross section
6 to 22	4 mm ²
30 to 44	10 mm ²

Electronic soft starter DIGISTART STV 1312

3.3.2 - Cross-section of earthing cable

Equal to the cross-section of the power cables.

3.3.3 - U.R. fuses (high speed fuses) definition

- Despite the rapid response time of the electronics, the thyristors must be protected against short-circuit by installation of correctly sized high speed. Otherwise the power bridge can be destroyed by such short circuits.

- The U.R. fuse ratings are determined by the starting duty and the thyristor I^2t .

Rating	Characteristics	BUSSMANN Ref.
6	25A - 660V	170 M 1311
10	40A - 660V	170 M 1313
16	63A - 660V	170 M 1315
22	100A - 660V	170 M 1317
30	125A - 660V	170 M 1318
44	160A - 660V	170 M 1319
Holder		170 H 1013

N.B. : The above references are liable to change to take into account latest developments and cannot be considered contractually.

- Please consult us for the supply of fuses and their holder.

3.4 - Control electronics supply connections



- Control power supply must be protected by using 2 fuses type GI 3.15 A.

The screw terminal block accepts stranded cable of 4 mm² maximum cross-section :

Reference	Function	Electrical character.
N/L - 230V	Control electronics supply	230V ± 10% 50/60Hz single phase supply
N/L - 400V		400V ± 10% 50/60Hz single phase supply

3.4.1 - Earth connection

The earth connection must be made at the product's general earthing point (PE)

3.5 - Remote control connections

3.5.1 - Terminal block description

Located at the bottom of the control board. The terminal block comprises 9 screw terminals which accept shielded stranded cable of 2.5 mm² maximum cross-section.

3.5.2 - Terminal designation

	Reference	N° of terminal	Designation	Function/Characteristic
Outputs		1	K1 relay - Trip relay Closed on power up Open on trip or on power down	Normally open relay Max. voltage 250V AC Switching power : 3A resistive load
		2		
Inputs		3	K2 configurable output relay (1)	
		4		
		5	Ground terminal	Connection of shielding
	Run Stop Com	6 7 8	Run - stop control inputs	For permanent connection: 6-8 linked 7-8 run command: Closed = Run Open = Stop For momentary action: 6-8 Run command momentary close 7-8 Stop command momentary open
	Reset	9	Trip reset input	Momentary close terminals 9 and Com.

(1) See AE, section 4.5.

3.5.3 - Cable selection

Remote control connections should be made with shielded twisted cable, the shielding grounded at one end only, by connection to the ground terminal supplied.

Electronic soft starter DIGISTART STV 1312

3.6 - Standard connections

3.6.1 - Standard connection diagram

400V mains supply, **momentary Run/Stop** control signals.

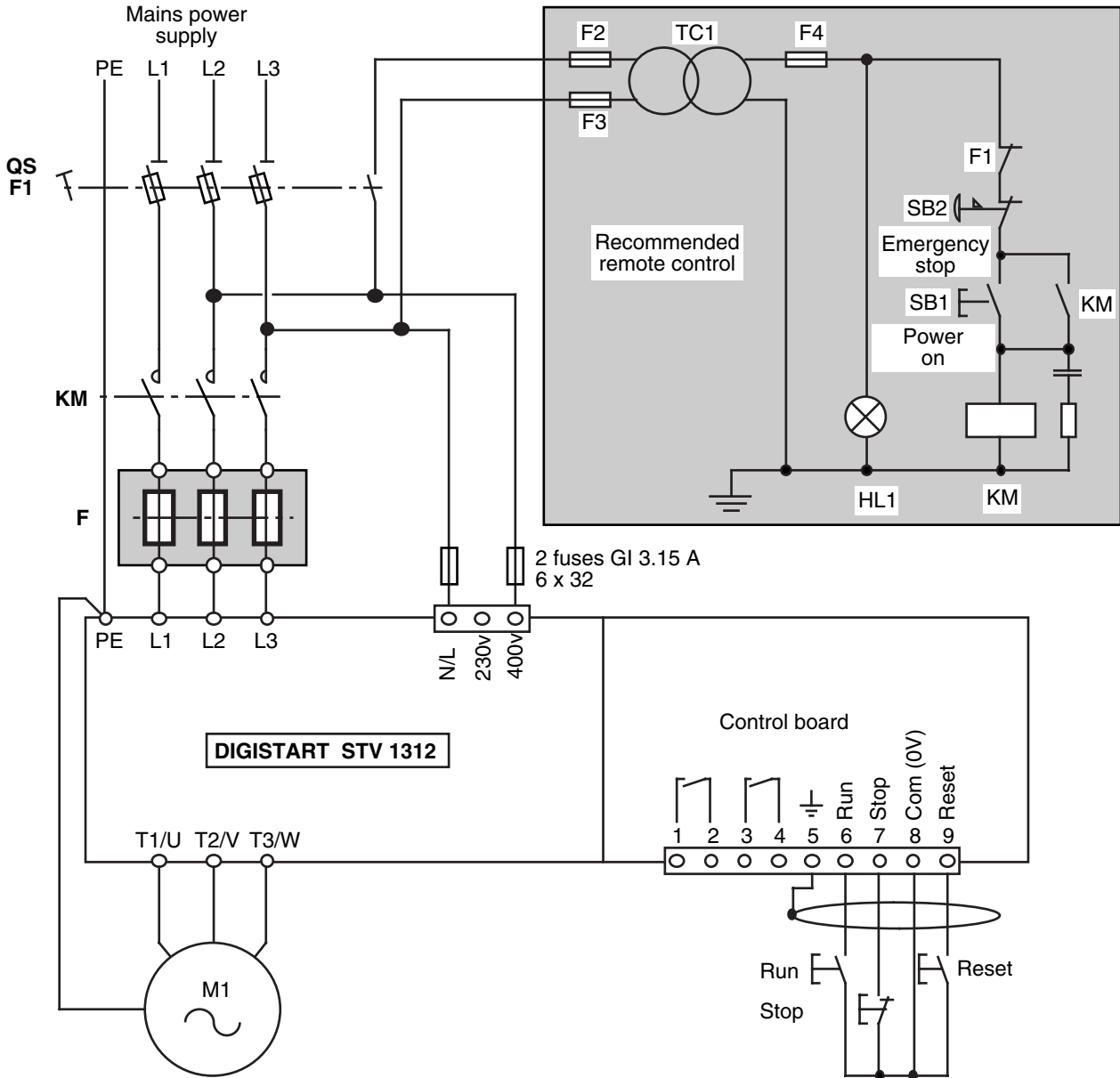

3.6.2 - Recommendations

KM : The **KM line contactor** should remain closed (except for emergency stop)

The **motor control signals** are given by Run-Stop push buttons connected to the control board terminal block (terminals 6.7.8).

F : **Fuses** are available as an option with the necessary mounting accessories.

The connections between the fuses and the DIGISTART should be as short as possible.

The **electronic supply** can be given by the power supply, or by a separate supply. Connections are made to the terminals provided (N/L-230V - 400V).

Switching off the electronic power supply resets the thermal protection calculation. The supply must thus be connected before the km contactor.

Electronic soft starter DIGISTART STV 1312

3.7 - Special connections

3.7.1 - Common examples

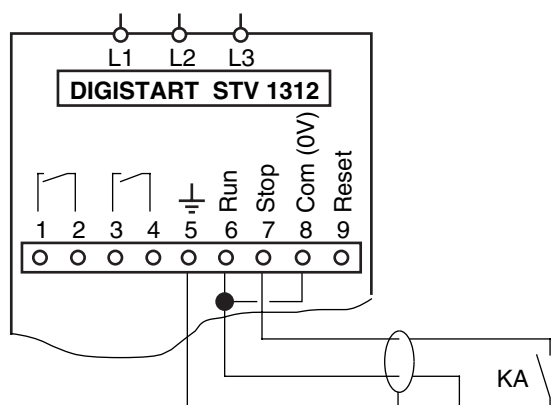
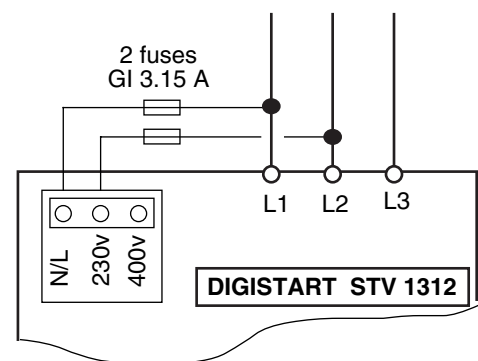
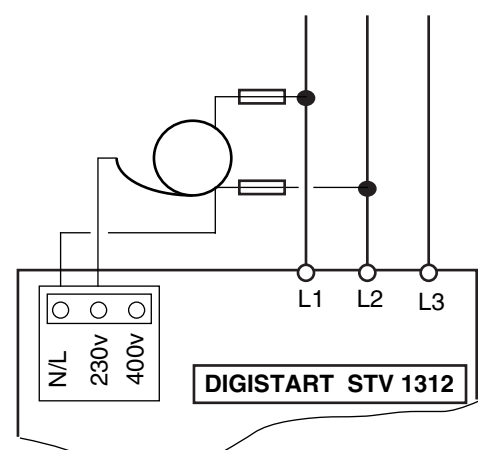
ALTERNATIVES	REMARKS
<p style="text-align: center;">Run/Stop control signals via self-maintained contact</p> 	<ul style="list-style-type: none"> - Link terminals 6 and 8. - Give run command via terminals 7 and 8 (KA closed = Run) - The control system must be designed so that the KA contact opens if there is a fault.
<p style="text-align: center;">230V three phase mains supply</p> 	<ul style="list-style-type: none"> - Remove the phy blocking the 230V terminal and use the N/L- 230V terminals for the control electronics supply connections. - It is preferable to connect the control power supply before the main contactor in order for the control board to remain energized while the power circuit is open.
<p style="text-align: center;">Other mains supplies than 230V or 400V</p> 	<ul style="list-style-type: none"> - Use an auto-transformer to adapt the available supply to 230V. - Remove the phy blocking the 230V terminal and connect the output of the auto-transformer to the 230V and N/L terminals of the control electronics supply. - For auto-transformer sizing, refer to indicated consumptions (see section 1.3). - Please consult LEROY-SOMER for the supply of an auto-transformer. - It is preferable to connect the control power supply before the main contactor in order for the control board to remain energized while the power circuit is open.

3.7.2 - Other connections

Other special connections are available on request, such as :

- Cascade starting of several motors with a single DIGISTART,
- Simultaneous control of several motors with a single DIGISTART,
- Control of 2 speed/2 winding motors,
- Control of 2 speed Dahlander motors,
- Control of a brake motor, ...

Electronic soft starter DIGISTART STV 1312

3.8 - Radio-frequency interference

3.8.1 - Immunity

The DIGISTART STV 1312 complies with the international immunity standards.

Standard	Type of immunity	Application	Level
EN 61000-4-2	Electrostatic discharge	Housing of equipment	Level 3 (industrial)
EN 61000-4-3	Radiated radio frequency	Housing of equipment	Level 3 (industrial)
ENV 50140	Radiated radio frequency	Housing of equipment	Level 3 (industrial)
ENV 50141	Emitted radio frequency	Control and power cables	Level 3 (industrial)
EN 61000-4-4	Successive rapid transients	Control cables	Level 3 (industrial)
		Power cables	Level 3 (industrial)
EN 50082-1	Generic immunity standards, Part 1 : residential, commercial and light industry	-	Complies
EN 50082-2	Generic immunity standards, Part 2 : industrial environment. Concern basic standards marked with*	-	Complies

3.8.2 - Conducted and radiated emissions

If the wiring instructions are carried out as requested, the DIGISTART STV 1312 complies with the conducted emission standards.

Standards	Missions	Level
EN55011	Conducted on power supply from 150 kHz to 30 MHz	Complies
EN55011	Radiated emission from 30 to 1000 MHz	Complies

Electronic soft starter DIGISTART STV 1312

4 - COMMISSIONING



- The soft starters use a software, which is adjusted with parameters.
- The performance level depends on the parameter setting.
- Incorrect settings may have severe consequences for personnel and machinery.
- The parameter setting of the soft starters should only be carried out by experienced and qualified personnel.
- Before powering up the DIGISTART make sure that power connections are correct (on both DIGISTART and motor side) and rotating parts are mechanically protected.
- Make sure when powering up that no accidental start is possible by any means.

4.1 - Setting procedure

- Each function or setting parameter is given a number or **address**.

Example: Motor In = address n°1 = **A1**

- Each address has an associated code or value called its **contents**. The contents are coded due to the fact that the basic product has only one display unit (see table in section 4.5.2).

Example :

• The motor In is equal to 85% of the DIGISTART rating : the contents of **A1** = 85 = code **7**.

• The DIGISTART is set up by programming the different addresses with the corresponding values for the given application. Programming is made via the 3 pushbutton keypad.

It is recommended for safety reasons, (accidental run signal), to program the DIGISTART with the power stack (L1-L2-L3) off.

4.2 - Pushbuttons/display presentation

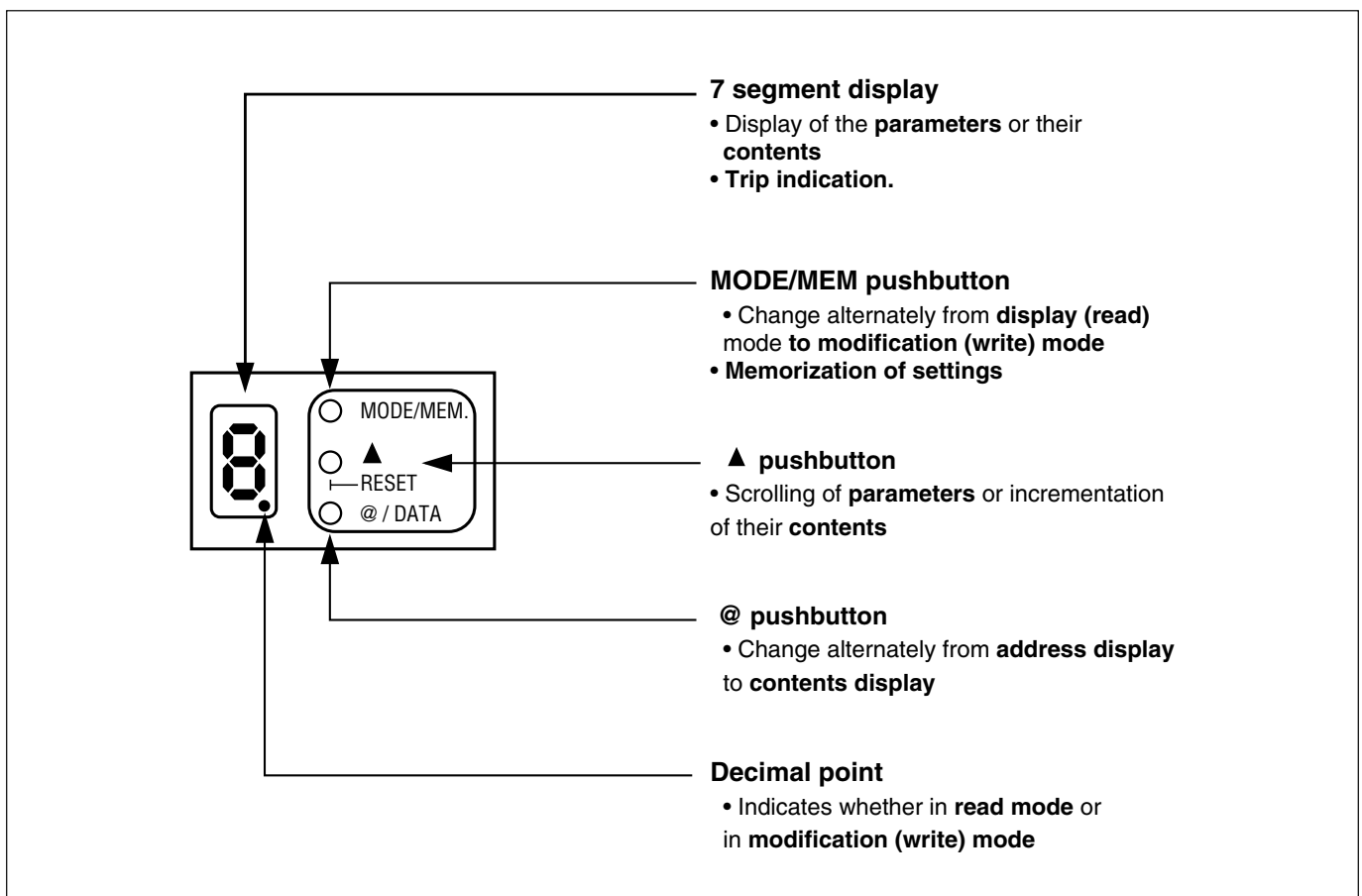

The pushbuttons are accessed by either removing the front cover or via a plastic screwdriver delivered with the DIGISTART.

Electronic soft starter DIGISTART STV 1312

4.3 - Status indication

The different operating status are identified by a combination of 7 segment display and decimal point indications, see following table :

Display status	Decimal point status	Mode	Remarks
Steady on	Off	Read	Choice of display : absorbed current ; absorbed power or system operating phase
Flashing	Off	Tripped	Alternate display of a 2 figure trip code
Flashing	On	Modification (address)	Address display : "A" alternates with the number of the address
Steady on	Flashing	Modification (contents)	Contents display : coded value to be modified
Steady on	On	Modification (memorization)	Contents display : coded value which has been memorized

4.4 - Switching on control electronics

4.4.1 - Verification

Before switching on, check :

- That the supply voltage is compatible with the control electronics supply voltage.
- The connection and tightness of : N/L - 230 V terminals, if the supply voltage is in the range 208 to 230V ; N/L-400V terminals, if the supply voltage is in the range 380 to 415V. (N.B. : Use an external auto-transformer for other voltage values).
- Correct earthing of the DIGISTART casing
- That there are no short-circuit or earth faults in the wiring.

4.4.2 - Procedure

- Switch on the DIGISTART control electronics
- The 7 segment display comes on and indicates : **C**.
- Press the MOD/MEM push button to change to modification (write) mode.

4.5 - Programming



- **The values of the motor parameters affect motor protection and safety of system.**
- **Set values of the parameters must be read on the nameplate of the motor.**
- **Motor parameters must be adjusted with a minimum accuracy of 10% of rated values in order to achieve good performance.**

4.5.1 - List of addresses and definitions

A1 : Rated motor current : I_n

- Setting of the rated current of the motor supplied by the DIGISTART
- Calculated as a % of the DIGISTART current rating and rounded to the nearest multiple of 5.

Example : DIGISTART : 22, 15 A motor

$I_n = 15/22 = 68.2\%$ rounded to 70.....code 4.

A2 : Starting current

- The current applied to the motor as soon as the "run" signal is given.
- Expressed as a % of rated motor current.
- Must be as low as possible whilst still ensuring motor rotation as soon as the "run" signal is given.

A3 : Ramp time

- Ramp time between starting current and current limit,
- Adjustment of the "smoothness" of the start, expressed in seconds,
- Does not represent the actual starting time.

A4 : Current limit

- Expressed as a % of the rated motor current.
- Adjustment of the maximum output current of the DIGISTART.
- Must be as low as possible whilst still ensuring starting under the most severe operating conditions.
- The current limit is active for all operating phases.

A5 : Kickstart

- Possibility of enabling or disabling the kickstart function.
- Full voltage is applied to the motor for 3 mains cycles, followed by the progressive starting phase.
- Application example : machines which tend to stick when stopped.

A6 : Maximum start time

- The DIGISTART trips if the time to start after a "run" signal exceeds this programmed value.
- To program, time the start duration under the most difficult load conditions and set A6 just above this value.
- Example : Maximum effective start time of 18 seconds, adjust the maximum start time protection to 20 seconds : code 2.

A7 : Motor thermal and locked rotor protection

- Possibility of enabling or disabling these two trips.
- This protection must be enabled if there is no thermal relay in the motor power circuit.

A8 : Under/overload trip enable

- Possibility of enabling or disabling the under/overload protections.
- When enabled, the DIGISTART trips if the absorbed motor power is greater than the threshold set at address **A9** or less than the threshold set at address **AC**.
- Fixed time delay of 2 seconds before trip.

Electronic soft starter DIGISTART STV 1312

A9 : Overload trip threshold

- Expressed as a % of the rated motor power.
- Read the maximum absorbed power when running under the most difficult load conditions and adjust the threshold to just above this value.
- Application : protection against mechanical jamming, bearing-wear detection.

AC : Underload trip threshold

- Expressed as a % of the rated motor power.
- Read the minimum absorbed power when running under the least difficult load conditions and adjust the threshold to just below this value.
- Application : loss of pump-priming, transmission slip or failure.

AE : Configuration of relay K2

- Selection of the function of relay K2.
- Possible choices :

Address contents	function	Relay status for different operating conditions				
		Tripped	Starting	Running	Decelerating	Stopped
0	General trip	0	C	C	C	C
1	Motor accelerating	0	C	0	0	0
2	Motor power on	0	C	C	C	0
3	Start complete	0	0	C	0	0
4	Overload alarm	0	0	see	0	0
5	Underload alarm	0	0	diag.	0	0

N.B. : K2 relay is open when the DIGISTART power is off.

The relay status for overload and underload alarms is determined by the following diagram. The delay times $\Delta t1$ and $\Delta t2$ allow instantaneous power peaks without change of relay status.

Under/overload alarm diagram :

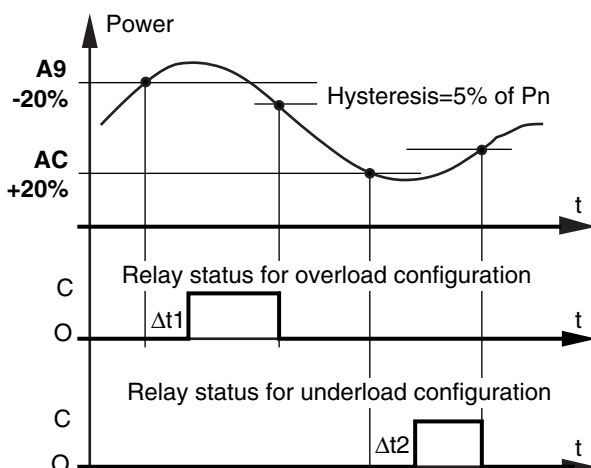

AF : Restart after mains dip

- Enable or disable the flying restart after mains dip function.
- If enabled, for a mains dip of less than 1.5 seconds during normal running, the DIGISTART automatically applies full voltage to the motor (current limitation is active).

AH : Power factor control

- Enable or disable the power factor improvement function when running at no load.
- Due to the values of motor time constants, it is not advisable to use this function for applications with abrupt load variations and low inertias.

AL : Controlled deceleration

- Enable or disable the function which decreases the motor voltage progressively during the deceleration phase.
- If the function is disabled, the motor voltage is switched off as soon as the stop signal is given.
- Applications : **Installations where motor stop is abrupt on power down (pumps...).**

AO : Controlled deceleration time

- Time taken for full motor voltage to decrease to 0V when the controlled deceleration function is enabled.
- Allows progressive stop control.

AP : Direction of rotation enable

- Enable or disable the reversal of rotation protection.
- The standard configuration of the DIGISTART is for direct phase order (L1, L2, L3). If the protection is enabled, wiring up the phases in an indirect order will cause the DIGISTART to trip (16 on the display). Invert two phases to eliminate the fault.

AU : Selection of operating display

Display, when running, of one of the following parameters :

- **Absorbed current** : Expressed in % of $I_n/10$.
- **Absorbed power** : Expressed in % of $P_n/10$
 - Example: 50% of P_n --> display 5..
 - N.B. : **h** indicates >100%.
- **Operating condition** : see table :

Code	Operating condition
C	DIGISTART power off
E	DIGISTART power on Motor power off
F	Accelerating
H	Full motor voltage
L	Controlled deceleration

Electronic soft starter DIGISTART STV 1312

4.5.2 - Table of parameters

The addresses and their contents are given below ; shaded boxes correspond to the factory (default) settings :

Designation / Address		Value corresponding to displayed code																	Units
		0	1	2	3	4	5	6	7	8	9	C	E	F	H	L	P	U	
Rated motor current	A1	50	55	60	65	70	75	80	85	90	95	100	105	110	115	120	125	130	% of rating
Starting current	A2	50	75	100	125	150	175	200	225	250	275	300	325	350	375	400	425	450	% of In
Ramp time	A3	0	2	4	6	8	10	12	14	16	18	20	25	30	35	40	45	50	Seconds
Current limit	A4	100	125	150	175	200	225	250	275	300	325	350	375	400	425	450	475	500	% of In
Kickstart	A5	No	Yes																
Maximum start time	A6	0	10	20	30	40	50	60	70	80	90	100	110	120	130	140	150	160	Seconds
Motor thermal and locked rotor protection	A7*	0	1	2	3														
Under/overload trip enable	A8*	0	1	2	3														
Overload trip threshold	A9	0	10	20	30	40	50	60	70	80	90	100	110	120	130	140	150	160	% of Pn
Underload trip threshold	AC	0	10	20	30	40	50	60	70	80	90	100							% of Pn
Configuration of relay K2	AE*	0	1	2	3	4	5												
Restart after mains dip	AF	No	Yes																
Power factor control	AH	No	Yes																
Controlled deceleration	AL	No	Yes																
Controlled deceleration time	AO	0	2	4	6	8	10	12	14	16	18	20	25	30	35	40	45	50	Seconds
Direction of rotation enable	AP	No	Yes																
Selection of operating display	AU*	0	1	2															

* See below

A7 : 0 Motor thermal and locked rotor protections disabled
1 Motor thermal protection enabled
2 Locked rotor protection enabled
3 Motor thermal and locked rotor protections enabled

A8 : 0 Under/overload trips disabled
1 Underload trip enabled
2 Overload trip enabled
3 Under/overload trips enabled

AE : 0 General trip
1 Motor accelerating
2 Motor power on
3 Start complete
4 Overload alarm
5 Underload alarm

AU : 0 Operating condition
1 Absorbed current
2 Absorbed power

Electronic soft starter DIGISTART STV 1312

4.5.3 - Programming examples

Example 1 :

Set address **A1** (rated motor current) to 85% :

		0	1	2	3	4	5	6	7	8	9	
		↔	↔	↔	↔	↔	↔	↔				
A1	Rated motor current	50%	55%	60%	65%	70%	75%	80%	85%	90%	95%	Etc

The corresponding code to be programmed is : **7**.

Example 2 :

Set address **A4** (current limit) to 300% :

		0	1	2	3	4	5	6	7	8	9	
A1												
A2												
A3												
		↔	↔	↔	↔	↔	↔	↔	↔			
A4	Current limit	100%	125%	150%	175%	200%	225%	250%	275%	300%	325%	350%

The corresponding code to be programmed is : **8**.

Example 3 :

Enable kickstart function via address **A5** :

		0	1	2	3	4	5	6	7	8	9
A1											
A2											
A3											
A4											
		↔									
A5	Kickstart	No	YES								

The corresponding code to be programmed is : **1**

Electronic soft starter DIGISTART STV 1312

4.5.4 - Manipulation of parameters

See example below :

Step	Action on keypad	Display	Remarks
Power up of control electronics		C.	On powering up the electronics, the DIGISTART displays operating status in read mode
Change to modification (Address) mode	MODE/MEM.	A. 1.	DIGISTART selects address 1 and displays alternately A with the N° of the address
Change to modification (Contents) mode	@	C.	The Contents of address A = C . Code C corresponds to 100% (see section 4.5.2)
Setting of rated motor current	▲	7.	18.5 A motor, DIGISTART 22 --> In motor = 18.5/22 = 84% rounded to 85 --> code 7.
Memorization	MOD/MEM.	7.	If the setting is not memorized, the decimal point flashes
Change to modification (Address) mode	@	A. 1.	
Select address A2	▲	A. 2.	
Change to modification (Contents) mode	@	6.	The Contents of A2 = 6 . 6 corresponds to 200% (see section 4.5.2)
Set starting current to 150%	▲	4.	A2 code 4 corresponds to 150 % (see section 4.5.2)
Memorization	MOD/MEM.	4.	
Change to address mode	@	A. 2.	
Select A3	▲	A. 3.	
Change to contents mode	@	C.	The Contents of A3 = C . C corresponds to 20 s (see section 4.5.2)
Set ramp time to 10 s.	▲	5.	A3 code 5 corresponds to 10 s (see section 4.5.2)
Memorization	MOD/MEM.	5.	
Change to address mode	@	A. 3.	
Select A4	▲	A. 4.	
Change to contents mode	@	F.	The Contents of A4 = F which corresponds to 400% (see section 4.5.2)
Set current limit to 300%	▲	8.	A4 code 8 corresponds to 300% (see section 4.5.2)
Memorization	MOD/MEM.	8.	
Change to read mode	MOD/MEM.	C.	In modification (address, contents, memorization) mode , press MOD/MEM to change to read mode

In modification mode, if no pushbutton is pressed on the keypad for around 3 minutes, the display returns automatically to read mode.

Electronic soft starter DIGISTART STV 1312

4.6 - Switching on power stack



- Make sure that all protections are on before powering up.

Before power up, check :

- the connection and tightness of L1-L2-L3 and T1/U, T2/V, T3/W terminals.
- that the DIGISTART casing is earthed.
- that the control electronics terminals are correctly supplied.
- a voltage is always present at the supply terminals of the control electronics.
- that the programming is correct for the application.
- that the mains power supply voltage does not exceed the maximum plated voltage.

SWITCH ON THE POWER BRIDGE.

- The display changes from **C** to **E**.

4.7 - Starting

- Give the DIGISTART a start signal and observe the motor's acceleration.
- Give the DIGISTART a stop signal and observe the motor's deceleration (for controlled deceleration mode).
- Readjust the DIGISTART settings following the procedure given in chapter 5 "Faults/Diagnostics" if the acceleration and deceleration characteristics are not satisfactory
- Depending on the final starting and operating characteristics, readjust if necessary, the protection settings.
eg. : maximum starting time.
Underload or overload threshold....

4.8 - Settings lock

Access to all parameters (except AU) can be prevented by placing the "Prog" link in position 0 or by removing it. The link is situated on the control board and can be accessed by removing the front cover .

4.9 - Reverting to factory settings



- Before going back to factory setting, make sure that the safety of the system will not be affected.

It is possible to return the starter's settings to their default (factory) values provided the following two conditions are satisfied :

- the " Prog " link is in position 1,
- the DIGISTART is in read mode and the power to the motor is off (the display indicates **C** or **E**).

Procedure:

- Carry out the following sequence in less than 10 s :

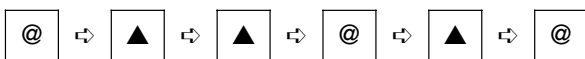

- At the end of this sequence, a **t** on the display indicates that the return to factory settings has been made.

After reverting to factory settings, the DIGISTART electronics supply should be switched off so that the new configuration is taken into account and undergoes the auto-test.

Electronic soft starter DIGISTART STV 1312

5 - FAULTS / DIAGNOSTICS

5.1 - Possible causes of malfunction

5.1.1 - On power up of the control electronics

- **Incident 1** : Display doesn't light up.

Check :

- the supply voltage to the electronics,
- the fuse.

- **Incident 2** : A trip code flashes on the display . See table in section 5.3.

5.1.2 - When programming

- **Incident 3** : Modification of the address contents is not possible.

Check that the "Prog." link which locks the settings is in position 1.

5.1.3 - On power up of the power stack

- **Incident 4** : Current is supplied to the motor without a run signal.

Check the condition of the thyristors.

5.1.4 - On starting

- **Incident 5** : The motor does not start and no current is supplied to the motor when a run signal is given.

Check :

- that there is mains voltage on L1, L2, L3,
- the connections between the control board and the power board,
- the connections between the power board and the thyristors,
- the condition of the thyristors.

- **Incident 6** : The motor does not start correctly although current is supplied to it.

Check that there is current in all **three** phases.

The starting current is not high enough to overcome resistive torque ; increase the starting current and the current limit.

- **Incident 7** : The motor begins to turn, but does not reach full speed.

The current is too low ; increase the current limit.

Check the motor connection (star or delta).

- **Incident 8** : The motor starts too abruptly.

Decrease the starting current.

- **Incident 9** : The motor starts too quickly.

Increase the ramp time.

- **Incident 10** : The DIGISTART output current is limited to less than the setting in address **A4**.

Check the motor connection (star or delta).

5.1.5 - Deceleration

- **Incident 11** : On setting the deceleration time to maximum, the deceleration is still not satisfactory.

Please contact LEROY-SOMER.

5.2 - Trip indication

The DIGISTART has one 7 segment display unit, the trip codes are given by an alternate display of 2 figures.

See the table on the following page.

Electronic starter DIGISTART STV 1312

5.3 - List of trip codes and possible causes

Before modifying any DIGISTART settings, check that the cause of the fault is not due to an external problem.

Trip code	Fault designation	Probable cause	Checks to be made
01	Loss of mains supply	<ul style="list-style-type: none"> • Mains voltage less than 177V (=208V -15%). • Drop or loss of 2 or 3 phases. • Power supply loss greater than or equal to 1.5 s. 	<ul style="list-style-type: none"> • Check the power supply capacity. • Check the wiring, fuses. • Check that the supply is stable and restart.
02	Excessive starting time	<ul style="list-style-type: none"> • Resistive torque abnormally high. • "Maximum start time" setting is too low for application 	<ul style="list-style-type: none"> • Check that there are no mechanical problems hindering the start (friction, etc). • Readjust the value of address A6.
03**	Thyristor over temperature	<ul style="list-style-type: none"> • Duty or operating cycle too severe for the DIGISTART. 	<ul style="list-style-type: none"> • Reduce the number of starts or change the starting characteristics by adapting the settings. • Check that the DIGISTART continuous output current is compatible with its rating
04	Phase loss	<ul style="list-style-type: none"> • Loss of one phase. • Phase voltage imbalance greater than 50% 	<ul style="list-style-type: none"> • Check : <ul style="list-style-type: none"> - the mains supply, - the wiring, the connections - the fuses, - the motor
05	Short loss of supply	<ul style="list-style-type: none"> • Short supply loss to power stack or control 	<ul style="list-style-type: none"> • Reset the trip and restart.
06**	Motor over temperature	<ul style="list-style-type: none"> • Operating cycle or load characteristic causes motor overheat 	<ul style="list-style-type: none"> • Check load characteristic. • Reduce motor load
07	Overload level	<ul style="list-style-type: none"> • The motor's absorbed power is greater than the threshold set by A9. 	<ul style="list-style-type: none"> • Check the loading. • If necessary, readjust the trip threshold A9.
08	Underload level	<ul style="list-style-type: none"> • The motor's absorbed power is less than the threshold set by AC. 	<ul style="list-style-type: none"> • Check the loading. • If necessary, readjust the trip threshold AC.
09	Control system fault	<ul style="list-style-type: none"> • Failure or malfunction due to high disturbance levels of the microcontroller. 	<ul style="list-style-type: none"> • Reset the trip and restart. • If reoccurrence, check that connection recommendations have been followed. • Consult LEROY-SOMER
12	Locked rotor	<ul style="list-style-type: none"> • Mechanical jamming of the motor shaft. • Load at start too high 	<ul style="list-style-type: none"> • Eliminate mechanical blockage. • Reduce loading.
14	Shorted thyristor	<ul style="list-style-type: none"> • Short-circuit of one or more thyristors 	<ul style="list-style-type: none"> • Check that no external element is short-circuiting the thyristors • Check the thyristors
15	Open thyristor	<ul style="list-style-type: none"> • Open circuit or non conduction of thyristor 	<ul style="list-style-type: none"> • Check the thyristor gate connections. • Check the supply, cables, connections, fuses, and motor. • Check the thyristors.
16	Phase sequence	<ul style="list-style-type: none"> • DIGISTART supply phase sequence doesn't correspond to the initial memorised order 	<ul style="list-style-type: none"> • Change over two of the DIGISTART's supply phases, if the original phase sequence is to be retained.
19*	Control supply loss	<ul style="list-style-type: none"> • Supply voltage less than 177V (=208V -15%). • 230V voltage supply connected to N/L - 400V terminals 	<ul style="list-style-type: none"> • Check the voltage value. • Check the protection fuse.

* Display disappears after short period of time.

** If the electronic power supply is switched off, wait 20 minutes before restarting. This time is necessary for the components to return to their " cold state ".

WARNING !

The trip is the consequence of a bad operation of the system which must be investigated. Make sure the fault is cleared before resetting.

Electronic soft starter DIGISTART STV 1312

6 - MAINTENANCE



• All work related to the soft starter installation, commissioning and maintenance must be carried out by experienced and qualified personnel.

• Do not carry out any work before the soft starter power supply has been switched off and locked, and wait 1mn until the capacitors have discharged.

• During maintenance operation with the soft starter powered-up, the personnel must stand on an insulating surface not connected to earth.

• During work on a motor or its power supply cables, make sure that the power supply of the corresponding controller has been switched off and locked.

• During tests, all protective covers must be kept in place.

6.1 - Care

6.1.1 - Introduction

The DIGISTART requires a minimum of maintenance and repair operations on the part of the user. Detailed below are normal maintenance operations.

6.1.2 - Maintenance

All electronic equipment may be subject to problems after being exposed to excessive heat, humidity, oil, dust, or if any external matter is allowed to penetrate.

- Periodically re-tighten connections.
- Printed circuits and their components do not normally require any maintenance, except periodic dust removal. Contact your retailer or nearest approved service centre if any problems occur.

CAUTION :

- Do not remove printed circuit boards during the guarantee period, as this will immediately render it null and void.
- Do not touch integrated circuits or the microcontroller with your fingers, or with any charged or live material.

6.2 - Spare parts list

Designation / Ratings	6	10	16	22	30	44
Control board (all ratings)	PEF 470 NA 000					
Power board (voltage code 14)	PEF 470 NB 100					
Power board (voltage code 16)	PEF 470 NB 200					
Supply fuse	PEL 002 FU 002					
Thyristor (voltage code 14)	ESC 046 MT 000	ESC 046 MT 000	ESC 025 MT 002	ESC 056 MT 003	ESC 046 MT 000	ESC 066 MT 000
Thyristor (voltage code 16)	ESC 046 MT 001	ESC 046 MT 001	ESC 025 MT 003	ESC 056 MT 004	ESC 046 MT 001	ESC 066 MT 001
Power fuse	PEL 025 FU 002	PEL 040 FU 003	PEL 063 FU 002	PEL 100 FU 002	PEL 125 FU 002	PEL 160 FU 002
Fuse holder	APE 200 PF 000					
Front cover with labels	COF 015 CA 003 + PSI 122 EA 002					

Electronic soft starter DIGISTART STV 1312

7 - SUMMARY OF SETTINGS

DIGISTART type :	
DIGISTART N° :	
Commissioning date :	
Machine reference :	

Designation		Factory setting	Your setting date :	Your setting date :	Your setting date :	Your setting date :
Rated motor current	A1	100%				
Starting current	A2	200%				
Ramp time	A3	20 s				
Current limit	A4	400%				
Kickstart	A5	No				
Maximum start time	A6	30 s				
Motor thermal and locked rotor protection	A7	1				
Under/overload trip enable	A8	0				
Overload trip threshold	A9	120 %				
Underload trip threshold	AC	30 %				
Configuration of relay K2	AE	3				
Restart after mains dip	AF	No				
Power factor control	AH	No				
Controlled deceleration	AL	No				
Controlled deceleration time	AO	20 s				
Direction of rotation enable	AP	No				
Selection of operating display	AU	0				





MOTEURS LEROY-SOMER 16015 ANGOULEME CEDEX-FRANCE