

X2 X3 - AC Gearless

Installation and maintenance

X2 - X3 - AC Gearless Receipt - Storage Commissioning

In order to obtain complete satisfaction with your new LEROY-SOMER gearless machine, it is important to comply with the following instructions.

IMPORTANT :



Contact with any live or rotating parts may cause injury. Never touch the motor during operation, as this is likely to become hot.

Installation, servicing and maintenance must only be carried out by a qualified member of staff.

LEROY-SOMER cannot be held responsible for any problems arising from failure to comply with the instructions in this manual.

The machine is under warranty as long as it is not partially or completely dismantled without LS assistance (or approval) during the warranty period.

CAUTION

Make sure the car is mechanically immobilized before performing any maintenance on the motor or on the brake.

1. - RECEIPT

Initial checks :

- As soon as you receive the machine, inspect the state of the packing and the machine. In the event of any damage having been caused by transportation, notify your haulage contractor.

- Next, ensure that the identification plate conforms with the contract specifications and certified data.

2. - STORAGE

2.1 - Storage area

The storage area must be dry, and sheltered from the elements. With a minimum temperature of -40°C , it should not be subject to frequent temperature variations (to avoid the risk of condensation), and should be free from vibration, dust and corrosive gases.

2.2 - Long-term storage (> 3 months)

- Place the motor in an horizontal position in a sealed watertight package (heat-sealed bag, for example) containing a deshydrating sachet and bag large enough to protect the machine, taking account of its size and the humidity in the storage area.

- The grooves of the traction sheave are protected by a special wax; don't remove this protective film, it protects the exposed surfaces.

- In case of vibrations in the warehouse, it is recommended to rotate the traction sheave twice a month minimum (this can be done by releasing brake with manual released system or by opening brake arms). After operation put the brake back into its original position. Make sure the protective paper between the lining and the brake wheel is still in position.

3. - ENVIRONMENT

Rated characteristics for these motors are given for a normal environment (specified in IEC 34.1) :

- altitude 1000 m or less,
- maximum relative humidity: less than 95%,
- temperature between -16 and $+40^{\circ}\text{C}$.

More stringent specifications can be accommodated by derating if the particular requirements are stated at the time of ordering.

4. - COMMISSIONING

4.1 - Insulation inspection (before installation)

If the motor has been stored for several months, it is essential to check that :

- the inside is clean and free of condensation;
- the motor is correctly insulated (minimum of $>100\text{ M}\Omega$ powered at 500 V.D.C.) after disconnection of all the electronic circuits.

WARNING : *Do not apply the megohmmeter to the thermal detector terminals, as this may damage them.*

If the correct insulation value is not reached, the motor should be dried out as follows :

4.1.1 - By heating externally

- Place the motor in an oven at 70°C , ensuring all openings are free of obstruction, for 24 hours or more until the correct insulation is obtained.

- Take care to rise the temperature gradually to avoid condensation.

- While drying, make regular checks on the insulation values which will tend to fall initially and then rise.

4.1.2 - By heating internally

Connect the three motor winding in serial. Supply them with a low DC voltage (to get 10% of rated current calculated with the winding resistors) increase voltage until the current get 50% of rated current. It must be supplied during approximately four hours. The temperature of the housing shall not exceed 50°C .



4.2 - Installation

Incorrect lifting methods may be dangerous for personnel and may cause serious damage to the machine.

Check that the machine weight is below the lifting capacity of any sling or hook. The only way to properly lift the complete machine is to attach it by points which are recommended (see figure 1 page 3).

Motors should be installed in a location where cooling air (which must be low in humidity, free of dust, steam and corrosive gases) can enter and exit freely. Ensure that warm air emissions cannot be drawn back in (motor against a wall for example).

X2 - X3 - AC Gearless Commissioning

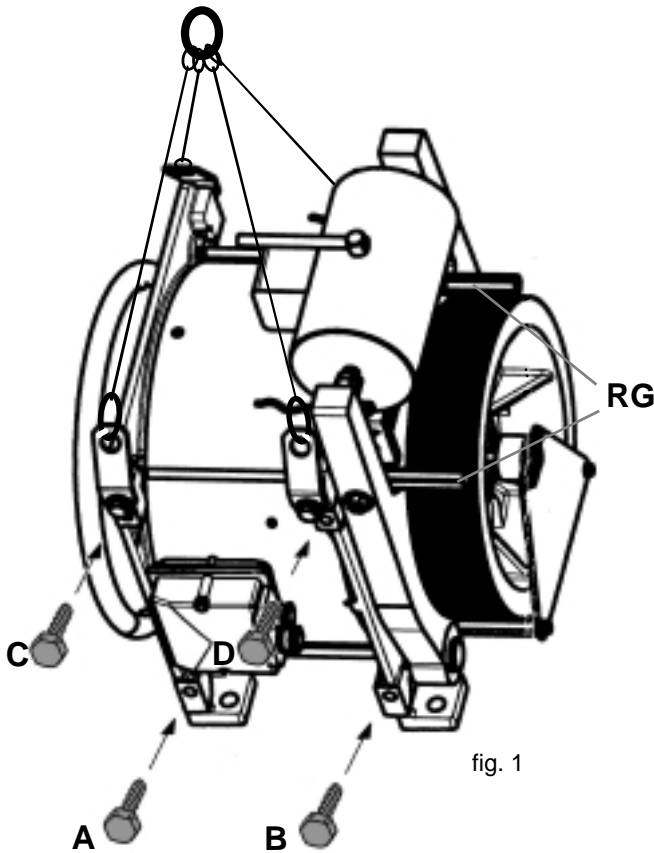

fig. 1

4.2.1 - Cleaning

- Release the brake by hand with the brake lever, or release the brake springs and open the brake arms, and remove the protection which is between the brake shoes and the brake wheel of the traction sheave.
- Remove any rust-protective wax from the sheave.



Do not use any abrasive material, but rather a cloth soaked in alcohol or solvent. Use a solvent which does not contain oil to avoid oil contamination of the friction surfaces.

WARNING: only use the solvent in a ventilated area. If the machines are delivered with a bed-plate and a secondary sheave, the secondary sheave has to be cleaned as well (see above).

4.2.2 - Mechanical installation

- The gearless machine must be installed on a bed-plate not subject to vibrations, and must be secured by four M20 bolts, nuts, and washers. The bolts must be secured only when ropes, car, counter-weight, traction sheave and secondary sheave are perfectly aligned. When this operation is completed, weld the plates attached to the U bolts of the secondary sheave if it is supplied.

When the gearless is placed in the basement and strength of the ropes on the traction sheave is upward it has to be fixed on the bedplate with two additive nuts M 20 placed on position B left and right side of the machine.

- Before installing the ropes, check that the traction sheave can rotate freely by releasing the brake and rotating the sheave by hand.

- When the ropes are installed, the two rope guards (RG) must be screwed .

The gearless can also be placed on right or left side fixed on the bedplate by four M 20 nuts (A, B, C, D), rope strength orientated downward.

4.3 - Connection

- See connection diagrams in the terminal boxes (motor, brake and blower if installed).

- Connect the motor using cables and connectors of an appropriate size.



- Check also that connectors are crimped onto the cables.

Be particularly careful when screwing on the terminal nuts (if done incorrectly, this could damage the connections by overheating : see figure 2).

- During installation, include safety devices to protect the motor.

- Connect the supply cables to the terminals U1, V1, W1 as per IEC 34.1 to have clock-wise rotation of the shaft.

- If case, connect thermistors to the remote control.

- Connect the earth terminal.

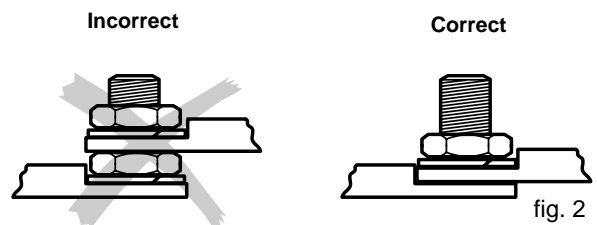
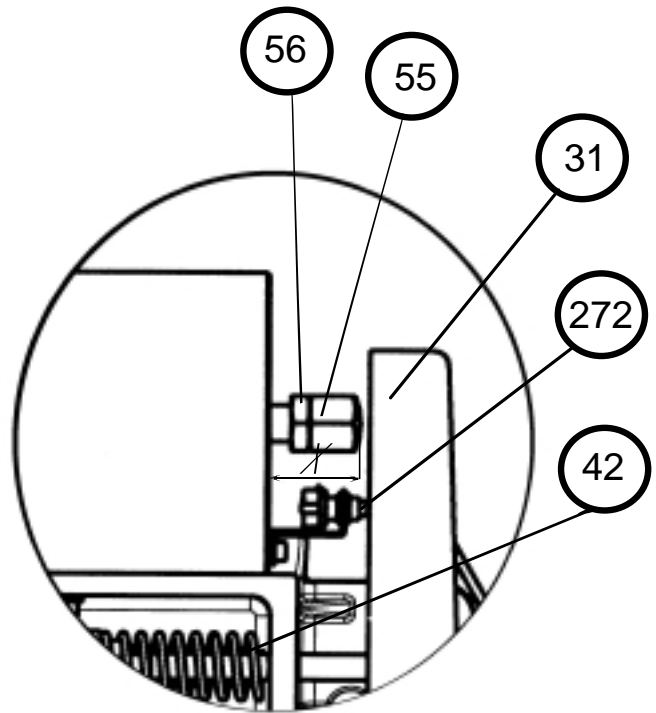
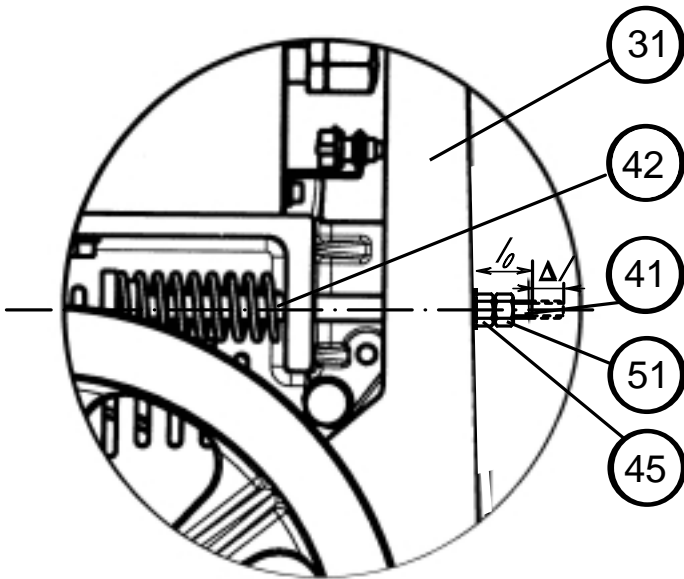

fig. 2

X2 -X3 - AC Gearless Commissioning



4.3.1 - Brake adjustment

4.3.2 - Definitions and limits

x : Plunger stroke travel.

l_0 : Torque adjust screw length when brake lining are just on contact with brake drum (no pressure).

Δl : Additive torque adjust screw length to induce a pressure on brake lining and get a brake torque.

4.3.3 - Torque adjustment

Before carrying out the adjustments, disconnect the brake supply. Screw 55 must not be in contact with the brake arm. Ensure the car immobilization by appropriate mechanical system.

- Unlock counter nut **51**.
- Adjust l_0 by tightening the nut **45** at maximum with nude hand.
- Adjust brake torque by adjusting the spring length with nut **45**.
- Lock counter nut **51**.

Brake torque is proportional to : Δl

4.3.4 - Plunger stroke adjustment

- Unlock counter nut **56**.
- Tighten brake stroke adjust screw **55** to its shortest position.
- Supply brake with holding voltage to place the brake plunger in open position.
- Untighten screw **55** to place it in contact with brake arm **31** (maximum possible with hand), brake arms must still remain closed. At that position $x = x_0$.
- Continue to untighten screw **55** with a spanner to get $x = x_0 + 2mm$
- Lock counter nut **56**.
- Once it has been done for the two sides of the brake, traction sheave must be free.
- Switch off brake supply.

For passenger safety :

- Check that brake torque is the required one.
- Check that brake manual release nut rotating gap exist and is sufficient.

4.3.5 - Microswitch adjustment

- Adjust the position of the two microswitches **272** once all operations here above are done.

X2- X3 - AC Gearless Servicing

5. - SERVICING

5.1 - First operation



Check that electrical machinery is properly grounded before carrying out the first operation to protect the staff from electric shock.

Run the machine and check the following points :

- abnormal noise,
- vibrations,
- action of switch contacts,
- all fixings and electrical connections are fully tightened,
- the state of the bearings,
- abnormal running,
- that the blower motor (when installed) is rotating in the correct direction.
- Check also the current and the voltage on the machine when it is running with rated load.

Important: *never run the machine without the blower switched on.*

5.2 - Maintenance

During service visits, for an optimized life expectancy of the machine, proceed with the following operations.

5.2.1 - Every month

- Check for loose bolts, nuts or electrical connections.
- Check for abnormal noise, vibration or abnormal running.
- Remove grease traces (if any) on the sheave and brake drum **28**.

5.2.2 - After one month, then every six months

- Check the brake springs are properly adjusted. If they are not, the springs must be readjusted (see section 4.4.2).
- Check the plunger stroke is properly adjusted. If it is not, the plunger stroke must be readjusted (see section 4.4.3).

5.2.3 - Every five years

- Secondary sheave bearing maintenance
Unscrew the two plugs. Replace them by a grease nipple. Grease with 70 to 75 g of the original grease (specified on Name plate).

Parts	Periodicity			
	1 month	6 months	1 year	5 years
Inspection and adjustments				
Bolts and nuts tightening	●			
Noise & vibration inspection	●			
Brake spring and stroke inspections		●		
Greasing				secondary sheave

X2 - X3 - AC Gearless Ordering spare parts

6. - ORDERING SPARE PARTS

To ensure efficient after-sales service, each order for spare parts should specify the following elements :

- motor type and serial n°
- and for each part :
- part description and (or) identification n°,

- quantity ordered.

For instant identification, please give the reference of the document used for ordering (plan or manual n°). Details of the type and serial n° appear on the motor identification plate.

X2 - X3 - AC Gearless Brake system

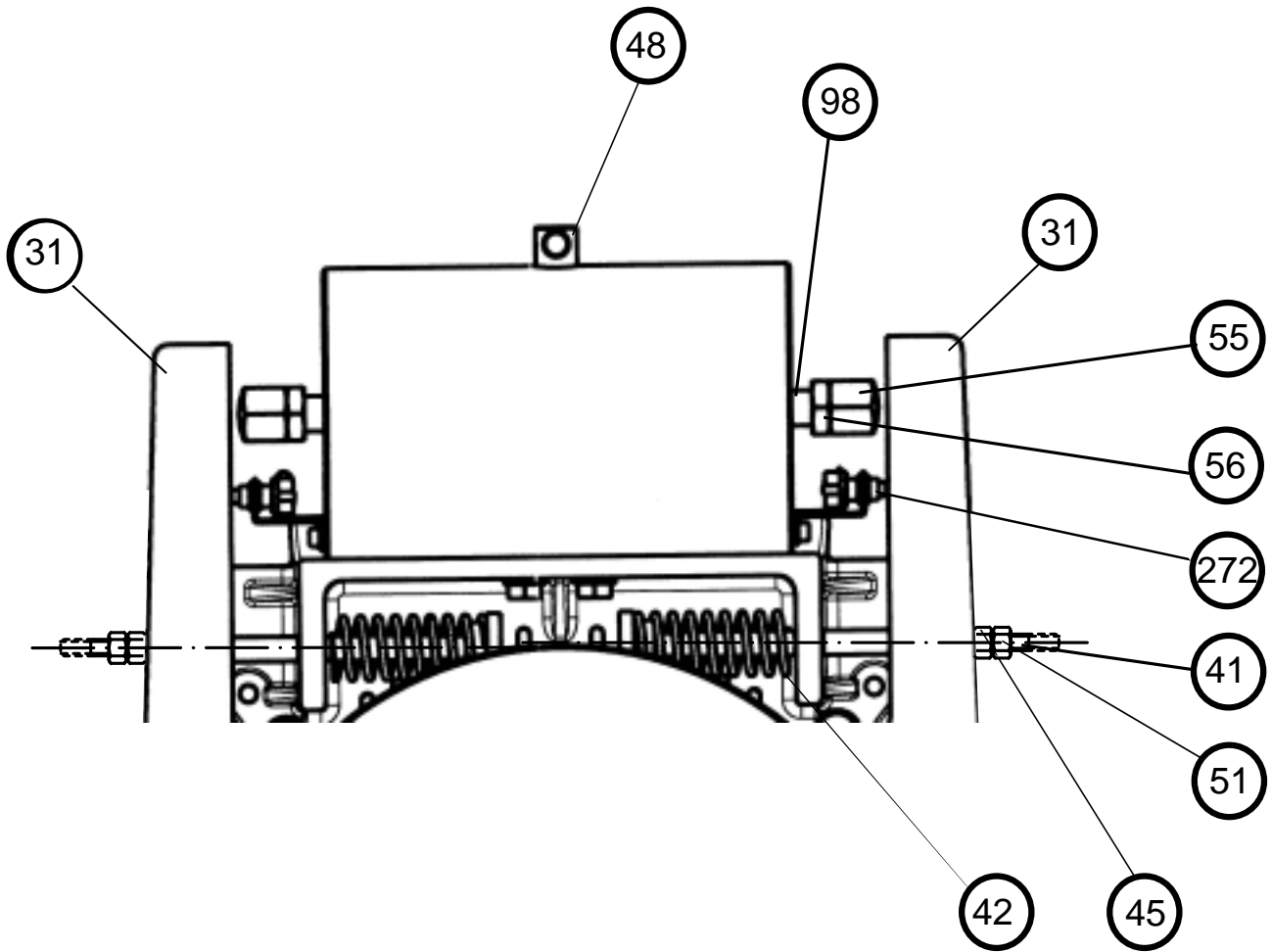

Part list*					
Rep.	Qty	Designation	Rep.	Qty	Designation
31	2	Brake arm	51	2	Torque adjustment counter nut
41	2	Torque adjustment screw	55	2	Stroke adjustment screw
42	2	Torque adjustment spring	56	2	Stroke adjustment counter nut
45	2	Torque adjustment nut	98	2	Plunger axle
48	1	Brake manual release lever	272	2	Microswitch

X2 - X3 - AC Gearless

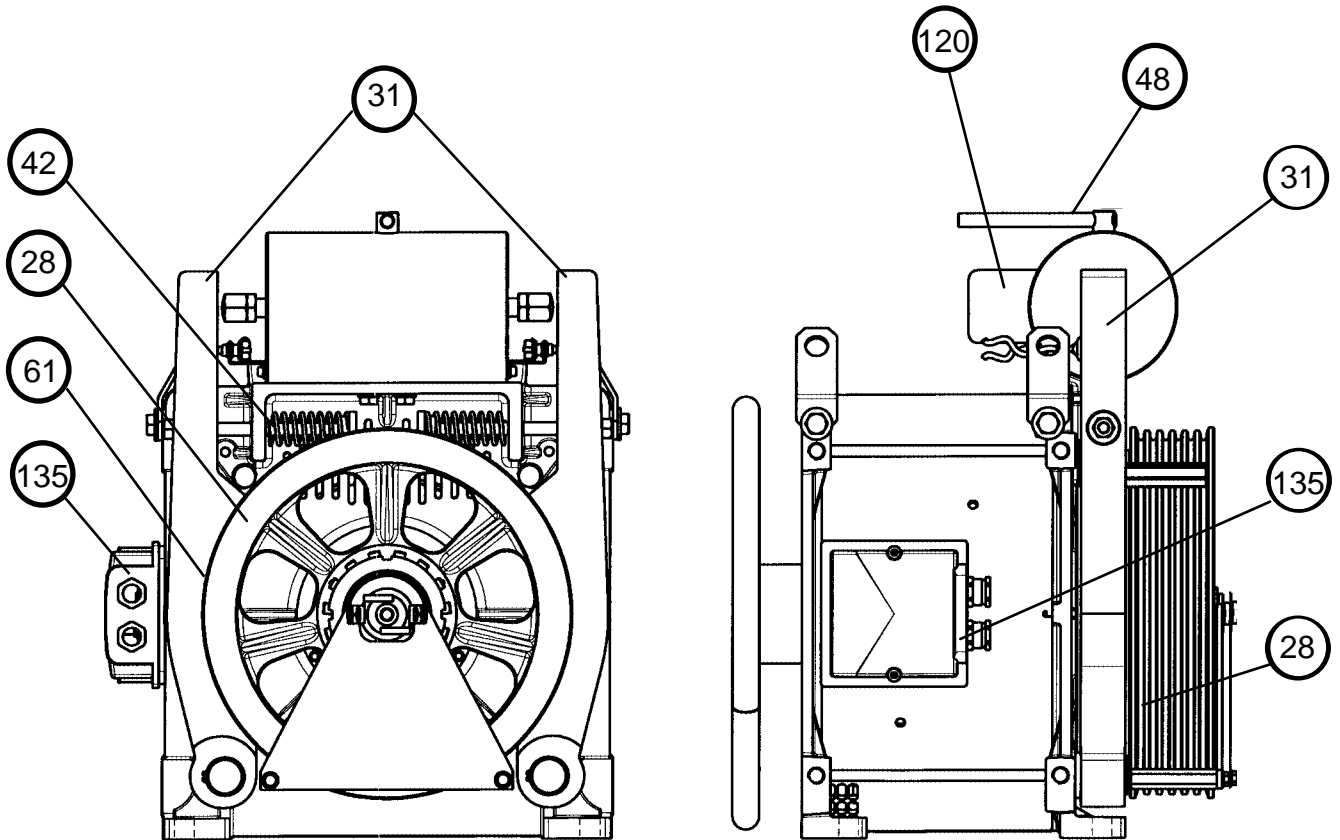

Part list*		
Rep.	Qty	Designation
28	1	Sheave and drum
31	2	Brake arm
42	2	Torque adjustment spring
48	1	Brake manual release lever
61	2	Lining
120	2	Brake terminal box
135	1	Motor terminal box



MOTEURS LEROY-SOMER 16015 ANGOULÊME CEDEX - FRANCE

RCS ANGOULÊME N° B 671 820 223
S.A. au capital de 131 910 700 F