

User Guide

Profibus-DP

Option Cards for
Unidrive and Mentor II

Part Number: 0447-0022
Issue Number: 2



Safety Information

Persons supervising and performing the electrical installation or maintenance of a Drive and/or an external Option Unit must be suitably qualified and competent in these duties. They should be given the opportunity to study and if necessary to discuss this User Guide before work is started.

The voltages present in the Drive and external Option Units are capable of inflicting a severe electric shock and may be lethal. The Stop function of the Drive does not remove dangerous voltages from the terminals of the Drive and external Option Unit. Mains supplies should be removed before any servicing work is performed.

The installation instructions should be adhered to. Any questions or doubt should be referred to the supplier of the equipment. It is the responsibility of the owner or user to ensure that the installation of the Drive and external Option Unit, and the way in which they are operated and maintained complies with the requirements of the Health and Safety at Work Act in the United Kingdom and applicable legislation and regulations and codes of practice in the UK or elsewhere.

The Drive software may incorporate an optional Auto-start facility. In order to prevent the risk of injury to personnel working on or near the motor or its driven equipment and to prevent potential damage to equipment, users and operators, all necessary precautions must be taken if operating the Drive in this mode.

The Stop and Start inputs of the Drive should not be relied upon to ensure safety of personnel. If a safety hazard could exist from unexpected starting of the Drive, an interlock should be installed to prevent the motor being inadvertently started.

General Information

The manufacturer accepts no liability for any consequences resulting from inappropriate, negligent or incorrect installation or adjustment of the optional operating parameters of the equipment or from mismatching the Drive with the motor.

The contents of this User Guide are believed to be correct at the time of printing. In the interests of a commitment to a policy of continuous development and improvement, the manufacturer reserves the right to change the specification of the product or its performance, or the contents of the User Guide, without notice.

All rights reserved. No part of this User Guide may be reproduced or transmitted in any form or by any means, electrical or mechanical including photocopying, recording or by any information storage or retrieval system, without permission in writing from the publisher.

Copyright	© October 1997 CT SSPD
Author:	CT SSPD
Issue Code:	2
Software Version:	DPL Toolkit V3.2
	UD70 System File V2.6.0
	UD73 Firmware V2.01
	MD24 Firmware V1.4.0

Contents

1	Introduction	1
1.1	Using this guide	1
1.2	Unidrive – UD73	1
1.3	Mentor II – MD24	2
1.4	Overview specification	2
2	Mechanical installation	3
2.1	Unidrive	3
2.2	Mentor II	4
3	Electrical installation	5
3.1	Profibus-DP connectors	5
3.2	Cable specification	6
3.3	Screen	7
3.4	Termination	7
3.5	Network limitations	8
4	Getting started	9
4.1	Profibus-DP node address	9
4.2	Network data rate	9
4.3	Network start-up	9
4.4	Trip action on network failure	9
4.5	Network interruptions	10

5	Cyclic data channel set-up	11
5.1	Parameter mapping	11
5.2	Mapping parameters on Unidrive	12
5.3	32 bit cyclic data channel (Unidrive only)	13
5.4	Mapping parameters on Mentor II	13
5.5	Mapping conflicts	14
5.6	Changing the parameter mapping	15
5.7	Saving Unidrive parameters	15
5.8	Saving Mentor II parameters	16
5.9	Control word	16
5.10	Status word	19
5.11	Disabling cyclic data channels	20
6	Non-cyclic data channel	21
6.1	Non-cyclic data transmission	21
6.2	Non-cyclic sub-protocol	21
6.3	Reading parameters	22
6.4	Writing parameters	24
7	Profibus-DP network configuration	27
7.1	Network data rate	27
7.2	Configuration telegram	27
8	Diagnostics	28
8.1	Determining if network is active on Unidrive	28
8.2	Cannot establish Profibus-DP connection	28
8.3	Network not updating Drive parameters	28
8.4	Unidrive trip codes	29
8.5	Mentor II trip codes	29

9	General information	30
9.1	Option module code (Unidrive only)	30
9.2	Firmware version (Unidrive only)	30
9.3	Number of network cycles (Unidrive only)	30
9.4	Profibus-DP timing	31
9.5	System propagation delays	32
10	Example application	33
10.1	System overview	33
10.2	IN cyclic data	35
10.3	OUT cyclic data	36
10.4	Network set-up	36
10.5	Digital I/O	37
10.6	Analog I/O	37
11	Appendix	38
11.1	Profibus-DP network operation	38
11.2	Error detection	38
12	Quick reference	39
12.1	Set-up and mapping parameters	39
12.2	General Drive functions	39
12.3	Control words	40
12.4	Status words	41

1 Introduction

1.1 Using this guide

Drive parameters are denoted in this manual by “#MM.PP”, where MM refers to the menu number, and PP refers to the parameter number within that menu. Please refer to the Unidrive and Mentor II manuals for parameter definitions.

1.2 Unidrive – UD73

The UD73 Profibus-DP Interface card for Unidrive is supplied in a large option module. It is an add-on card for the UD70 Applications card. An 80C32 processor and System Protocol Chip handle all network activity, and use a Dual-Port RAM interface to transfer data between the 80C32 and the UD70.

The UD70 retains full functionality, allowing the user to download normal DPL application programs. No program modifications are required to allow existing DPL programs to run. A different UD70 operating system file (*IBSPROFI.SYS*) is used, and the UD70 has this system file pre-loaded. The UD70 also uses a DPRAM interface to transfer data to and from the Drive.

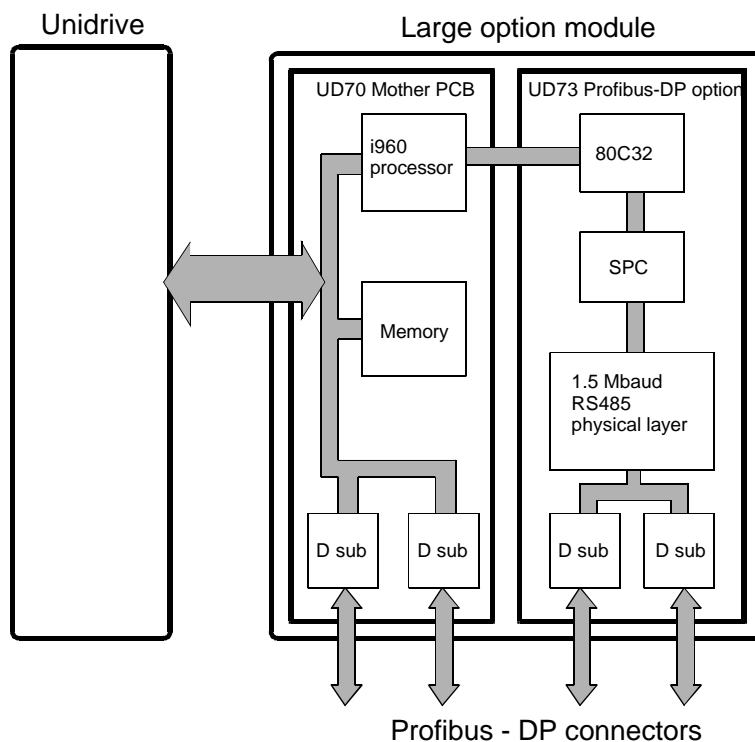

1.3 Mentor II – MD24

The MD24 Profibus-DP Interface card for Mentor II is a single add-on card. It fits onto the 40 pin header on the MDA-2B card on the Mentor II itself. An 80C32 processor and System Protocol Chip handle all network activity, and use a Dual-Port RAM interface to transfer data between the 80C32 and the Mentor II.

The MD24 does not have the MD29 hardware, and is unable to run DPL application programs.

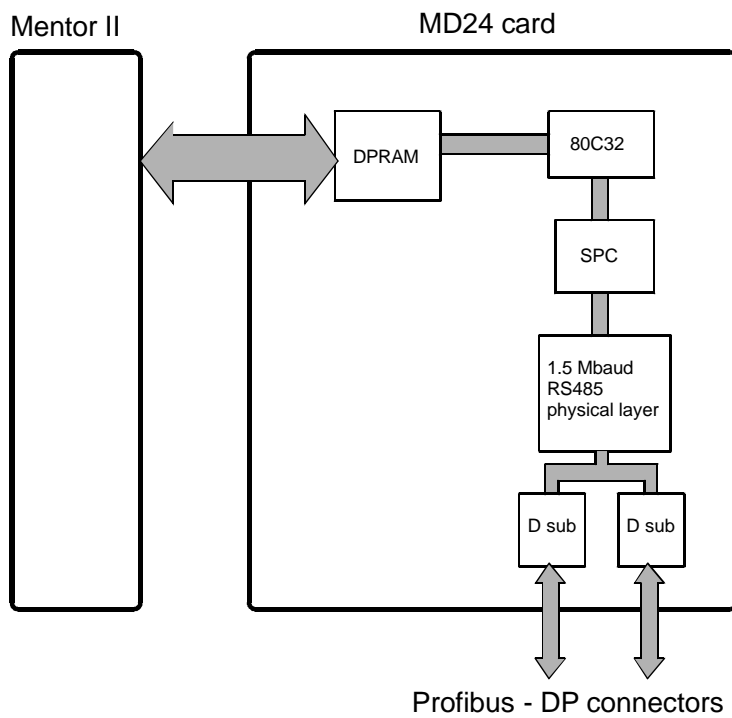

1.4 Overview specification

System	Profibus-DP The interface only supports Profibus-DP
Profibus-DP ID Code	3345
Data Rate	1.5 Mbits per second
Signalling	RS485
Galvanic Isolation	Yes
Connector	9 way D-type connector

2 Mechanical installation

Important

The Unidrive or Mentor II must be disconnected from the mains supply before installing or removing an option module.

2.1 Unidrive

- 1 Isolate the Drive from the mains supply and allow 5 minutes for the DC Bus capacitors to discharge.
- 2 Insert Large Option Module as shown below. Ensure that it is correctly inserted. The module will click firmly into place.
- 3 To remove the module, pull on the black tab, and the module will disengage from the connector and pull out of the Drive.

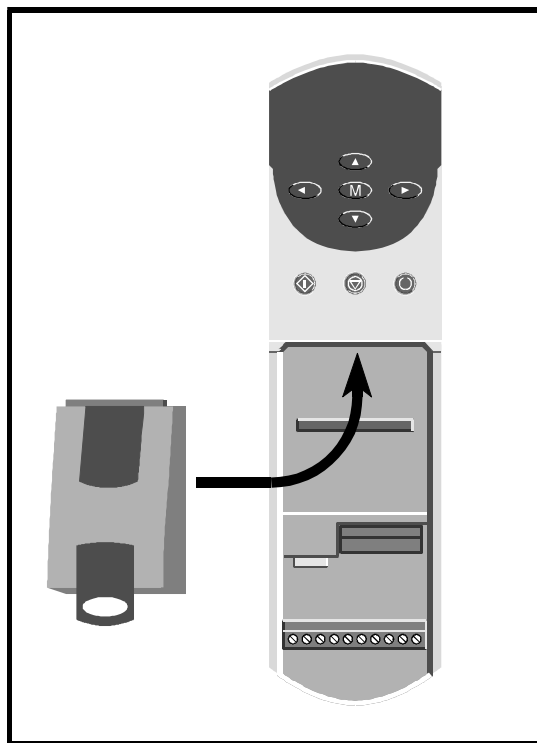

2.2 Mentor II

The MD24 is to be located upon a 40-way pin header (PL1) on the MDA2B circuit board, as shown below.

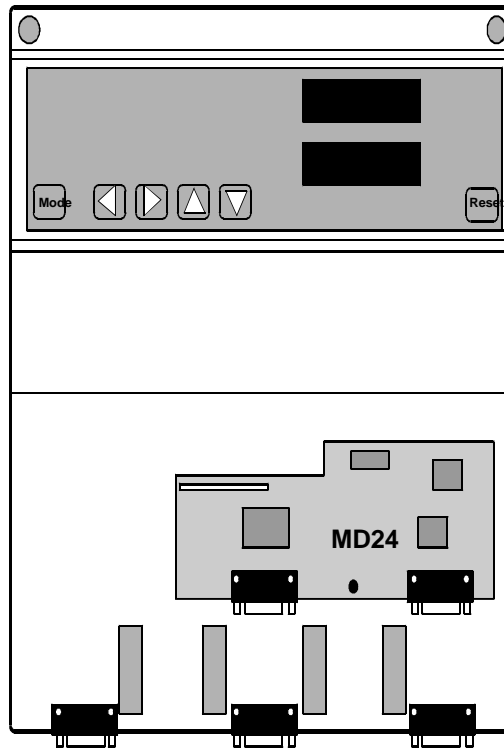

Warning

Please take extreme care when locating the board onto this connector - do not force it on. Excessive force may bend and break the pins of the header.

3 Electrical installation

3.1 Profibus-DP connectors

Both the UD73 and MD24 have two Profibus-DP 9-way D-Type connectors. (A and B on the large option module) The connectors are sockets (female), and are connected in parallel via the circuit boards to simplify the connection onto a multi-drop bus.

The connectors are shown below:

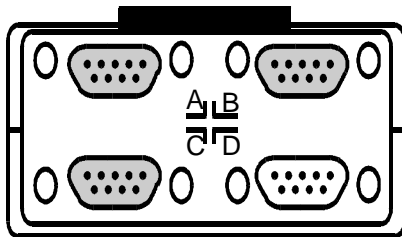

Unidrive large option module

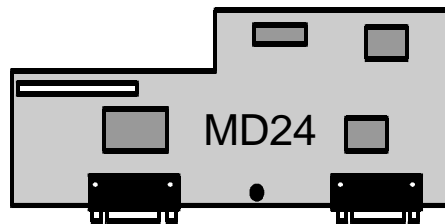

Mentor II Profibus-DP card

The pin out of the connectors are:-

9-way female D-type pin	Description
3	Data
8	/Data
5	0V Data
6	Remote power (+5V) for line termination
Shell	Screen

All connections including 0V Data must be connected, as show below:

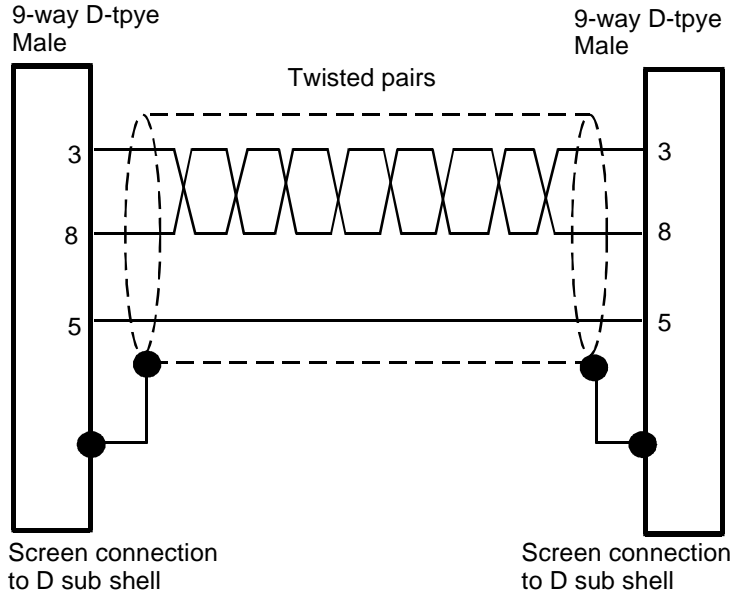

3.2 Cable specification

The following 4 core shielded twisted pair cable should be used for the connections:

Characteristic	Minimum value	Nominal Value	Maximum value	Comments
Impedance		150Ω		3 to 20 MHz
Conductor area	0.34 mm ²			
Capacitance (line - line)			30pF/m	
Capacitance (line - shield)			75pF/m	
Resistance			110Ω/km	
Line length			400m 200m	@500kbit/sec @1.5Mbit/sec

For further details refer to DIN 19245.

3.3 Screen

The screen of the cable must be connected to the metal D-type shell. Screw locks should be fitted to ensure that there is a reliable contact between the shells.

3.4 Termination

There is no termination resistor supplied on either the UD73 or MD24. It is the user's responsibility to make provision for this externally on the last node of the network using the following termination circuit: Refer to DIN19245 for more information.

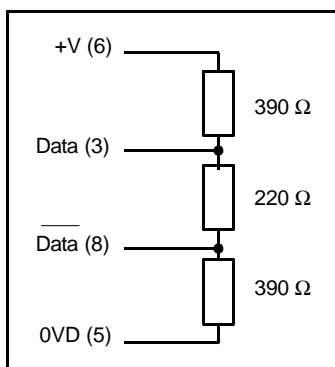

It is important that the Drive node where the network termination resistor is installed must remain powered up while the network is communicating with other nodes. If this is not the case, +5V and 0V may be run from another node that will always be powered up. +5V and 0V must be run INSIDE the screen of the Profibus-DP network cable.

3.5 Network limitations

The maximum number of nodes that can be connected to a single network without the use of repeater units is 32 nodes. The maximum line length at 1.5Mbits per second is 200m. Line length and the number of network nodes using line repeaters. Each line repeater must be considered as replacing a network node when installed, as each line repeater will add 1 unit load to the line. Terminating resistors must be installed at both ends of each twisted pair, even if the twisted pair section runs between two line repeaters. A maximum of 3 repeaters is allowed between any two stations, hence the maximum number of nodes in a 4 section network is 122. One of these nodes will be designated as the Master Network Controller (usually a PLC), so only 121 actual slave nodes can be connected.

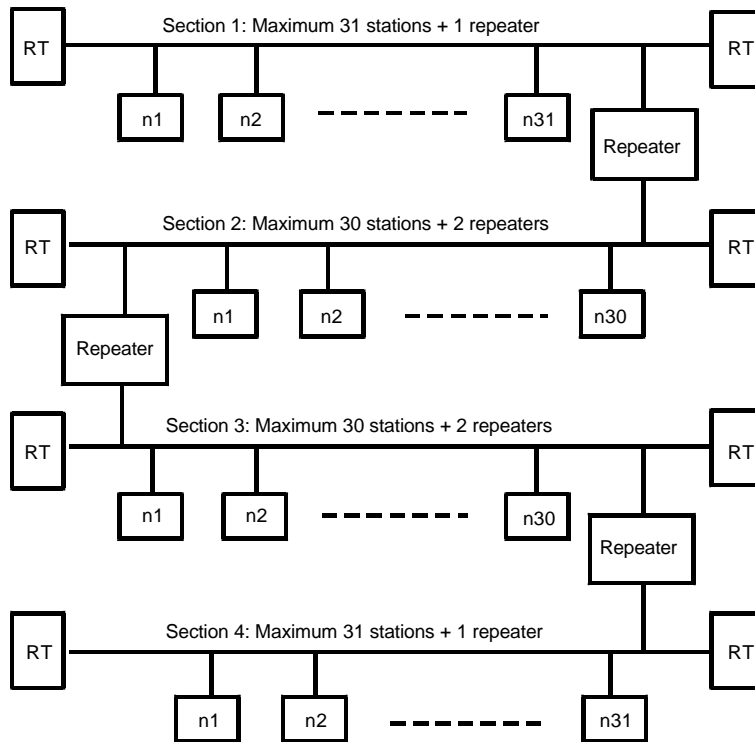

4 Getting started

4.1 Profibus-DP node address

Set the desired node address in Unidrive parameter #20.05 and Mentor II parameter #14.01. Valid addresses are between 1 and 124. If an invalid address is set, the UD73 or MD24 will fall back to the default address of 124. Node address changes only take effect after the UD73 or MD24 has been reset.

On Unidrive, a soft reset can be generated by setting #MM.00 to 1070 and pressing the red RESET button on the keypad. This only resets the UD70 and UD73 interface, not the Unidrive. The MD24 must be reset using the RESET button on the Mentor II keypad. (Note: if the Drive is enabled then a reset sequence will not be generated).

If the Unidrive or Mentor II is tripped, resetting the trip will also cause a full reset of the UD70/UD73 or MD24.

4.2 Network data rate

The UD73 and MD24 will automatically detect the data rate from the master when the network is initialised.

The UD73 and MD24 support following data rates (in bits per second):

9.6 Kbps 19.2 Kbps 93.75 Kbps 187.5 Kbps 500 Kbps 1.5 Mbps

4.3 Network start-up

The UD70 does not accept any data from the UD73 for the first 50 network cycles. This is a safety requirement that allows the PLC to calculate the full control word before the Drive starts accepting control words. This prevents any possibility of spurious RUN signals getting to the Drive before the PLC has fully initialised the control word.

4.4 Trip action on network failure

There is a trip function in the UD73 and MD24 that monitors the activity on the Profibus-DP network. The number of network cycles is counted every second, and displayed in #20.50 on Unidrive.

If the number of network cycles drops by more than 40% between successive measurements, the UD70 operating system will trip the Drive on tr60. This means that there could be a worst case delay of up to 1.4 seconds before the Drive will actually trip.

If it is essential that the time-to-trip is less than this value, #89.03 and DPL code can be used to trip out the Drive in the required time see Determining if network is active on Unidrive.

4.5 Network interruptions

If a Unidrive or Mentor II trips, then provided it is not due to a Profibus-DP network error, the whole network will continue to operate. OUT cyclic data (such as speed or torque references) received by the UD73 or MD24 will be passed to the Drive, however, the data will have no effect while the Drive is tripped. Care must be taken if the reference forms part of a closed loop system. It may be possible for the reference to saturate, and cause problems when the trip is reset. IN cyclic data being read back from the Drive will be frozen at the value when the trip occurred. The important point to note is that the rest of the network will continue to function normally.

If a Drive is providing the +5V and 0V supplies for the terminating resistor networks, then this node must be kept powered up at all times. If this cannot be guaranteed, then there are 2 options:

- A local +5V supply should be provided, with the 0V referenced to the system 0V.
- +5V and 0V can be run along the cable from a node that WILL always be powered up if the Profibus-DP network is running. In this case, the +5V and 0V cable MUST be run INSIDE the screen to prevent unwanted noise pickup in the cables.

If power is lost to a node, this does not prevent the network from continuing, or being re-started without the dead node. (PLC code may be required to ignore the dead node.) The Profibus-DP connectors on the UD73 and MD24 are connected in parallel, so the network is not physically interrupted.

If the Drive is physically removed from the system, one of three precautions must be taken:

- The UD73 or MD24 can be left connected to BOTH network leads.
- A one-to-one bridging lead can be connected temporarily to provide network continuity, including the screen connections.
- The Profibus-DP network connections to both up-stream AND down-stream nodes can be made to the same D type shell to provide continuity.

5 Cyclic data channel set-up

The Profibus-DP data window contains four 16-bit words for input and four 16-bit words for output data. The first input and output words are reserved for non-cyclic parameter access and therefore cannot be used as cyclic data channels. The mapping of the six remaining words (three input and three output) can be programmed to any Unidrive or Mentor II parameter, or UD70 virtual parameter. The mapping cannot be changed dynamically, as a reset of the UD70 or MD24 must be performed to make the changes active.

On Mentor II, the internal values of the real parameters have a higher resolution than the display values. Therefore, when writing a value to a Mentor II real parameter, the value must be multiplied by 16 before being converted to hexadecimal.

Example. to write a value of 1000 (0x03E8) to #1.18, the actual value that must be transmitted via the Profibus-DP network is 0x3E80.

This also permits higher resolution on the speed loop. To write a value of 235.5 to #1.18, transmit 0xEB8 to the Mentor II. Although this fraction will not be shown on the display, the internal values in the Mentor II will use this extra resolution.

5.1 Parameter mapping

The following diagram illustrates the concept of programmable mapping with Unidrive parameter #20.PP controlling the mapping.

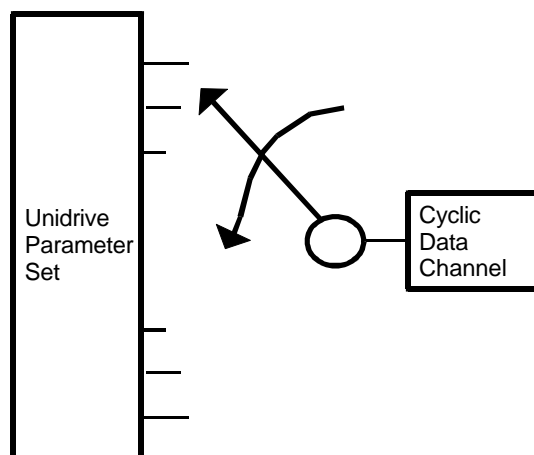

For example the following diagram illustrates the mapping process on Unidrive.

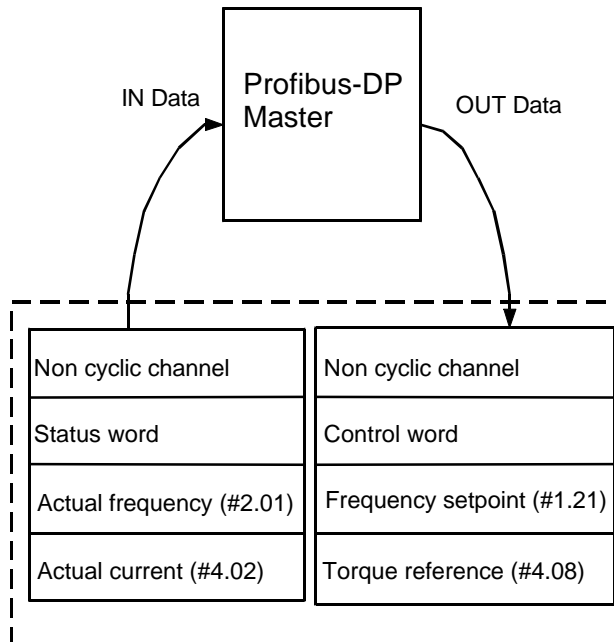

5.2 Mapping parameters on Unidrive

The mapping for Unidrive and UD73 is set using menu 20 parameters. Default mapping status is shown in the table below.

Cyclic channel	Mapping parameter	Default mapping status
IN Word 0	----	Reserved for the non-cyclic data channel.
IN Word 1	#20.07	Default map = 0, Drive status word.
IN Word 2	#20.03	Default map = #2.01, post-ramp speed reference.
IN Word 3	#20.04	Default map = #4.02, torque-producing current.
OUT Word 0	----	Reserved for the non-cyclic data channel.
OUT Word 1	#20.06	Default map = 0, Drive control word.
OUT Word 2	#20.01	Default map = #1.21, digital speed reference 1.
OUT Word 3	#20.02	Default map = #4.08, torque reference.

If any mapping parameter is set to an invalid value (target parameter is read-only or does not exist), the mapping will revert back to the default value when the UD70 is reset. The control and status words can be programmed to channel 1 by setting the mapping to 0. If it is necessary to use channels 2 or 3, the mapping must be set to #90.11 and #10.40 respectively.

If a cyclic channel is not being used, it can be disabled by setting the mapping to -1.

5.3 32 bit cyclic data channel (Unidrive only)

A 32 bit cyclic channel can be created for either IN data, OUT data or both, by combining channels 2 and 3. This allows the 32 bit registers (`_Pxx%`, `_Qxx%`, `_Rxx%` and `_Sxx%`) in the UD70 to be written to and read from by the controlling PLC. (See the User guide for the UD70 for more information)

The 32 bit channel is automatically configured when the mapping for channel 2 (#20.01 or #20.03) is directed to a 32 bit register. These are addressed as #70.xx for `_Pxx%` registers up to #73.xx for `_Sxx%` registers. The mapping values for channel 3 (#20.02 and #20.04) are disabled if channel 2 is directed to a 32 bit register.

Channel 3 contains the data high word (upper 16 bits of the register) and channel 2 contains the data low word (lower 16 bits of the register).

5.4 Mapping parameters on Mentor II

The mapping for Mentor II and MD24 is set using menu 11 parameters. Default mapping status is shown in the table below.

Cyclic channel	Mapping parameter	Default mapping status
IN Word 0	----	Reserved for the non-cyclic data channel
IN Word 1	#11.01	Default map = 1941, status word.
IN Word 2	#11.02	Default map = #3.02, speed feedback.
IN Word 3	#11.03	Default map = #5.01, current feedback.
OUT Word 0	----	Reserved for the non-cyclic data channel
OUT Word 1	#11.04	Default map = 1940, control word.
OUT Word 2	#11.05	Default map = #1.18, digital speed reference 2.
OUT Word 3	#11.06	Default map = #4.08, torque reference.

If any mapping parameter is set to an invalid value (target parameter is read-only or does not exist), the mapping will revert back to the default value.

If a cyclic channel is not being used, it can be disabled by setting the mapping parameter to 1999.

5.5 Mapping conflicts

When the mapping parameters for the Profibus-DP cyclic channels are set, care must be taken to ensure that there are no clashes with the mapping of the analog and digital inputs within the Drive. Neither the UD73 or MD24 will indicate if there is a conflict of mapping parameters. This only applies to analog and digital inputs, and OUT data on the Profibus-DP network.

If a parameter is written to from two different sources, the value of this parameter will depend entirely upon the scan times for the analog or digital input and the Profibus-DP network. Further confusion may be caused due to the update rate of the display. A parameter may appear to be steady at a particular value, but occasionally glitch in the value will be seen. In reality, this value may be changing continuously, leading to erratic Drive behaviour.

Drive input	Unidrive mapping parameter	Mentor II mapping parameter	Drive input	Unidrive mapping parameter	Mentor II mapping parameter
Analog 1	#7.10	#7.11	Digital 2	#8.13	#8.12
Analog 2	#7.14	#7.12	Digital 3	#8.16	#8.13
Analog 3	#7.18	#7.13	Digital 4	#8.19	#8.14
Analog 4		#7.14	Digital 5	#8.21	#8.15
Speed		#7.15	Digital 6	#8.23	#8.16
Cyclic 1	#20.06	#11.04	Digital 7		#8.17
Cyclic 2	#20.01	#11.05	Digital 8		#8.18
Cyclic 3	#20.02	#11.06	Digital 9		#8.19
Digital 1	#8.10		Digital 10		#8.20

To ensure that there are no mapping conflicts, check that each Unidrive mapping parameter and each Mentor II mapping parameter has a different value programmed. Analog and digital inputs can be de-programmed by setting the value to 0. Cyclic channels can be disabled by setting a mapping value of -1 on Unidrive, and 1999 on Mentor II.

With Mentor II, for example, analog input channel defaults to the torque reference, #4.08. This is also the default for cyclic data channel 3, so either analog input 4 (#7.14) or cyclic data channel 3 (#11.06) must be re-mapped before #4.08 can be controlled properly by either source.

Control word conflicts

The control word provides a method of writing to multiple bit parameters using one data word. If one of the cyclic data channels is writing to the control word, the following bit parameters for each Drive must not be controlled by any digital inputs.

Unidrive		Mentor II	
#6.15	#1.46	#1.11	#5.17
#6.30	#18.31	#1.12	#15.21
#6.31	#18.32	#1.13	#15.22
#6.32	#18.33	#2.02	#15.23
#1.45		#4.10	#15.25
		#4.12	#15.29
		#4.13	#15.31

5.6 Changing the parameter mapping

If any mapping parameters are changed, the new values only take effect after the UD70/UD73 or MD24 has been reset. On Unidrive, a soft reset can be generated by setting #MM.00 to 1070 and pressing the red RESET button on the keypad. The MD24 can be reset using the RESET button on the Mentor II keypad. (Note: if the Drive is enabled then a reset sequence will not be generated).

To keep any mapping changes permanently, (i.e. retained after power-down) the parameters must be stored.

5.7 Saving Unidrive parameters

Menu 1 through 19

All parameters in these menus are saved in the EEPROM in the Unidrive. To initiate the non-volatile save sequence, set #MM.00 to 1000 and press the red RESET button on the keypad.

Menu 20 and PLC parameters

All menu 20 parameters and PLC parameters (`_Pxx%` and `_Qxx%`) are stored in the FLASH memory of the UD70 in the large option module. To initiate the non-volatile save sequence for these parameters, set #17.19 to 1. The UD70 will then save menu 20, clear #17.19 back to zero and reset. The UD73 Profibus-DP interface will also be reset. These parameters can also be stored automatically at power-down, by setting #17.20 to 1.

5.8 Saving Mentor II parameters

To initiate the non-volatile save sequence, set #MM.00 to 1 and press RESET.

5.9 Control word

The control word is an efficient way of remotely controlling the Drive. Each bit in the control word has a particular function, and provides a method of writing to the bit parameters which control the operation of the Drive (RUN, JOG, DIRECTION, etc.) with a single data word.

Unidrive

The control word on Unidrive is mapped to channel 1 (default) by setting #20.06 to 0. (To map to channel 2 or 3, set #20.01 or #20.02 to #90.11.)

b15	b14	b13	b12	b11	b10	b9	b8
M6	M5	#18.33	M3	M2	M1	M0	#18.32

b7	b6	b5	b4	b3	b2	b1	b0
#18.31	#1.46	#1.45	Trip	#6.32	#6.31	#6.30	#6.15

The bits shown as Mx are individual mask bits which allow the corresponding bx to be masked. The Trip bit will cause a tr52 trip when set to 1. Parameters #18.31 to #18.33 are general user parameters and do not have mask bits.

The Unidrive should be set-up in PLC mode (#6.04 = 3), and the digital input control of the sequencing bits (#6.30 - #6.32) must be disabled. (Set #8.16, #8.19 and #8.21 to another value or 0.) The sequencing bits have the following functions:

Parameter	Sequencing bit	Function
#6.15	Enable	Enables the Drive. Display will show inh if set at 0, and depends on #6.30 if set to 1. Setting #6.15 to 0 will immediately disable the Drive when running. This parameter overrides #6.30.
#6.30	0	RUN. Display will show rdY if set at 0 and run when set at 1. Parameter is overridden by #6.15.
#6.31	1	JOG. Selects the JOG reference (#1.05) when set to 1.
#6.32	2	DIRECTION. Direction will be forwards if set to 0, and reverse when set to 1.

To reset the Drive using the Profibus-DP network, use the non-cyclic channel to set #10.38 to 100. The Drive will immediately clear #10.38 back to 0 and reset. (See Unidrive manual for more information.)

Example Unidrive control word values

15	14	13	12	11	10	9	8	7	6	5	4	3	2	1	0	Value	Action
0	0	0	0	0	0	1	0	0	0	0	0	0	0	0	0	0x0200	Drive disable
0	0	0	1	1	1	1	0	0	0	0	0	0	0	0	1	0x1E01	Enabled + stopped
0	0	0	1	1	1	1	0	0	0	0	0	0	0	1	1	0x1E03	Enabled + run fwd
0	0	0	1	1	1	1	0	0	0	0	0	1	0	1	1	0x1E0B	Enabled + run rev
0	0	0	1	1	1	1	0	0	0	0	0	1	1	1	1	0x1E07	Enabled + jog

Mentor II

The control word on Mentor II can be mapped to any OUT channel by setting the appropriate mapping parameter to 1940.

b15	b14	b13	b12	b11	b10	b9	b8
Valid	#15.31	#15.29	#15.25	Reset	#15.23	#15.22	#15.21

b7	b6	b5	b4	b3	b2	b1	b0
#2.02	#5.17	#4.13	#4.12	#1.13	#1.12	#1.11	#4.10

The VALID bit (**b15**) must be set to 1 for the Mentor II to accept and implement the message. The RESET bit will reset the Drive from a trip condition. NOTE: the reset sequence on Mentor II takes approximately 3 seconds, and the Drive Healthy signal is not returned until the sequence has finished.

Digital input control of the logic functions (#1.11 - #1.13) must be disabled by setting #8.21 to 1. The logic bits have the following functions:

Parameter	Function
#1.11	RUN PERMIT Must be set to 1 for the Drive to run.
#1.12	DIRECTION Direction will be forwards if set to 0, and reverse when set to 1.
#1.13	INCH Selects the Inch reference (#1.05) when set to 1.
#5.17	INHIBIT FIRING PULSES Set to 1 to enable the thyristor bridge firing pulses.

(See Mentor II manual for more information.)

Example Mentor II control word values

15	14	13	12	11	10	9	8	7	6	5	4	3	2	1	0	Value	Action
1	0	0	0	0	0	0	0	0	1	0	0	0	0	0	0	0x8040	Disabled
1	0	0	0	0	0	0	0	1	0	0	0	0	0	1	0	0x8082	Run fwd with ramps
1	0	0	0	0	0	0	0	0	0	0	0	0	1	1	0	0x8006	Run rev, no ramps
1	0	0	0	0	0	0	1	0	0	0	1	1	1	0	0	0x808E	Inch rev with ramps
1	0	0	0	0	0	0	0	0	1	0	0	1	0	1	0	0x8012	Torque control

Control word mapping

Bit	Unidrive - UD73		Mentor II - MD24	
	Parameter	Description	Parameter	Description
0	#6.15	Drive enable	#4.10	Current limit selector
1	#6.30	Sequencing bit 0	#1.11	Reference ON
2	#6.31	Sequencing bit 1	#1.12	Reverse selector
3	#6.32	Sequencing bit 2	#1.13	Inch selector
4	TRIP	Drive Trip (tr52)	#4.12	Torque Mode 0
5	#1.45	Preset select 0	#4.13	Torque Mode 1
6	#1.46	Preset select 1	#5.17	Inhibit firing
7	#18.31	Application bit	#2.02	Ramp enable
8	#18.32	Application bit	#15.21	Application bit
9	M0	Mask bit 0	#15.22	Application bit
10	M1	Mask bit 1	#15.23	Application bit
11	M2	Mask bit 2	RESET	Set to reset Drive
12	M3	Mask bit 3	#15.25	Application bit
13	#18.33	Application bit	#15.29	Application bit
14	M5	Mask bit 5	#15.31	Application bit
15	M6	Mask bit 6	VALID	VALID bit

The upper bits (b9-b15) of the Unidrive control word are individual mask bits which allow the corresponding bits (b0-b6) to be masked. If M0 (b9) is set then b0 of the control word controls parameter #6.15.

5.10 Status word

The status word is an efficient way of remotely monitoring and diagnosing the status of the Drive. Each bit in the status word indicates the status of a particular function of the Drive, e.g. at speed, zero speed, Drive healthy, etc., and provides a quick method of checking the current status of the Drive.

Unidrive

The status word on Unidrive is mapped to channel 1 (default) by setting #20.07 to 0. (To map to channel 2 or 3, set #20.03 or #20.04 to #10.40.)

b15	b14	b13	b12	b11	b10	b9	b8
X	#10.15	#10.14	#10.13	#10.12	#10.11	#10.10	#10.09

b7	b6	b5	b4	b3	b2	b1	b0
#10.08	#10.07	#10.06	#10.05	#10.04	#10.03	#10.02	#10.01

Mentor II

The status word on Unidrive can be mapped to any IN channel by setting the appropriate mapping parameter to 1941.

b15	b14	b13	b12	b11	b10	b9	b8
Error	#15.26	#10.09	0	#10.07	0	#10.05	#10.04

b7	b6	b5	b4	b3	b2	b1	b0
#10.03	#10.02	#10.01	0	#10.13	#4.25	#4.24	#10.12

Status word mapping

Bit	Unidrive - UD73		Mentor II - MD24	
	Parameter	Description	Parameter	Description
0	#10.01	Drive healthy	#10.12	Drive healthy
1	#10.02	Drive running	#4.24	Taper threshold 1 exceeded
2	#10.03	Zero speed	#4.25	Taper threshold 2 exceeded
3	#10.04	Running at or below minimum speed	#10.13	I*t Alarm
4	#10.05	Below set speed	0	Not used
5	#10.06	At speed	#10.01	Forward velocity
6	#10.07	Above set speed	#10.02	Reverse Velocity
7	#10.08	Load reached	#10.03	Current limit
8	#10.09	In current limit	#10.04	Bridge 1 enabled
9	#10.10	Regenerating	#10.05	Bridge 2 enabled
10	#10.11	Dynamic brake active	0	Not used
11	#10.12	Dynamic brake alarm	#10.07	At speed
12	#10.13	Direction commanded	0	Not used
13	#10.14	Direction running	#10.09	Zero speed
14	#10.15	Mains Loss	#15.26	Application bit
15	X	Not used	ERROR	Set if there is an error on one of the cyclic channels

5.11 Disabling cyclic data channels

If an application only requires 2 cyclic data channels, the remaining channel can be disabled. This means that the data received from that channel will not be written to any Drive parameter. It does not actually remove the channel from the network.

Unidrive

Set the appropriate channel mapping parameter to -1, and reset the UD70.

Mentor II

Set the appropriate channel mapping parameter to 1999, and reset the Drive.

6 Non-cyclic data channel

The non-cyclic data channel provides the controlling PLC with a method of reading from or writing to any parameter within the Drive. This channel can be used for single infrequent data transfers, or uploading and downloading parameter sets for a particular node. This would allow the PLC program detect new or replacement nodes, and download the required parameter set.

6.1 Non-cyclic data transmission

The non-cyclic data channel uses IN and OUT word 0 on each cycle of the network. Messages are transmitted word by word over consecutive network cycles, as defined by the sub-protocol. Both read and write commands take 4 network cycles to complete.

6.2 Non-cyclic sub-protocol

Each non-cyclic word or telegram is split into 2 bytes to implement the sub-protocol. The high byte is used as a control byte, and defines a read or write cycle, and contains a "stamp" to indicate which telegram it is in the message. When the node responds, another bit is used to indicate success or failure of the message.

b15	b14	b13	b12	b11	b10	b9	b8
R/W	Error	X	X	Stamp number			

b7	b6	b5	b4	b3	b2	b1	b0
Data	Data	Data	Data	Data	Data	Data	Data

Bit	Function	Values	Description
0 to 7	Data	0 to 255	Depends on the stamp number of the telegram. This byte contains either the menu number, parameter number, data high or data low bytes.
8 to 11	Stamp number	1 to 4	indicates the stamp number of the word. This shows which part of the message is currently in progress.
12, 13	Not Used	Not used	Not used. These should be set to 0.
14	Error	0 = Data OK 1 = Error	Indicates the success or failure of the message. Failure could occur if the parameter does not exist, or is a read-only or write-only parameter.
15	Read/Write	0 = Write 1 = Read	Defines whether the data word is part of a READ or WRITE cycle is in progress.

NOTE: X = don't care. Generally, these bits will be set to 0.

6.3 Reading parameters

To read parameters using the cyclic channel, the following telegrams must be sent on each network cycle to construct the final message.

- Telegram 1 Define menu number.
- Telegram 2 Define parameter number.
- Telegram 3 Request data high byte.
- Telegram 4 Request data low byte.

Telegram 1

The first telegram from the DP master indicates a READ cycle, and the stamp number is 1. The data byte would contain the menu number for the parameter that is to be read.

Bit	15	14	13	12	11	10	9	8	7	6	5	4	3	2	1	0
Value	1	X	X	X	0	0	0	1	0	0	0	0	0	0	1	1

Data word: 0x8103 Stamp number = 1 Menu number = 3

When the first telegram has been received and processed in the DP node, it is mirrored in the non-cyclic IN word.

Telegram 2

The second telegram from the DP master also indicates a READ cycle, but the stamp number is now 2. The data byte would contain the parameter number for the parameter that is to read.

Bit	15	14	13	12	11	10	9	8	7	6	5	4	3	2	1	0
Value	1	X	X	X	0	0	1	0	0	0	0	0	0	0	1	0

Data word: 0x8202 Stamp number = 2 Parameter number = 2

When the second telegram has been received and processed in the DP node, it is mirrored in the non-cyclic IN word.

Telegram 3

The third telegram from the DP master acts as the indication to the DP slave to send the data high byte from the requested parameter. The data byte is not used in this telegram, as the menu and parameter number have already been transmitted.

Bit	15	14	13	12	11	10	9	8	7	6	5	4	3	2	1	0
Value	1	X	X	X	0	0	1	1	X	X	X	X	X	X	X	X

Data word: 0x8300 Stamp number = 3

When the third telegram has been received and processed in the DP node, the node will respond with either the parameter data or an error message.

If telegrams 1 and 2 were received error free, and a valid parameter was interrogated, the DP slave will set the ERROR bit to 0 (b14 = 0) and the data high byte will be returned in bits 0 to 7.

Bit	15	14	13	12	11	10	9	8	7	6	5	4	3	2	1	0
Value	1	0	X	X	0	0	1	1	1	1	1	0	1	1	0	1

Data word: 0x8305 Stamp number = 3 Data high byte = 05

If telegrams 1 and 2 were not received correctly, or an invalid parameter was interrogated, (write only or does not exist) the DP slave will set the ERROR bit to 1 (b14 = 1). The data bits will have no significance.

Bit	15	14	13	12	11	10	9	8	7	6	5	4	3	2	1	0
Value	1	1	X	X	0	0	1	1	X	X	X	X	X	X	X	X

Data word: 0xC300 Stamp number = 3

Telegram 4

The fourth telegram from the DP master acts as the indication to the DP slave to send the data low byte from the requested parameter. Telegram 4 is only evaluated if the ERROR bit is set at 0 (b14 = 0) in telegram 3. The data byte is not used in this telegram, as the menu and parameter number have already been transmitted.

Bit	15	14	13	12	11	10	9	8	7	6	5	4	3	2	1	0
Value	1	X	X	X	0	1	0	0	X	X	X	X	X	X	X	X

Data word: 0x8400 Stamp number = 4

If there was no error in telegram 3, this returns the data low byte in the data bits.

Bit	15	14	13	12	11	10	9	8	7	6	5	4	3	2	1	0
Value	1	X	X	X	0	1	0	0	1	1	0	1	1	1	0	0

Data word: 0x84DC Stamp number = 4 Data low byte = DC

The final value of speed feedback = data high byte * 256 + data low byte
= 5 * 256 + 220
= 1500 rpm

6.4 Writing parameters

To write to parameters using the non-cyclic channel, the following telegrams must be sent on each network cycle to construct the final message.

- Telegram 1 Define menu number.
- Telegram 2 Define parameter number.
- Telegram 3 Set data high byte.
- Telegram 4 Set data low byte.

Telegram 1

The first telegram from the DP master indicates a WRITE cycle by setting the R/W bit to 0. The stamp number is set to 1. The data byte contains the menu number for the parameter that is to be written to.

Bit	15	14	13	12	11	10	9	8	7	6	5	4	3	2	1	0
Value	0	X	X	X	0	0	0	1	0	0	0	1	0	0	1	0

Data word: 0x0112 Stamp number = 1 Menu number = 18

When the first telegram has been received and processed in the DP node, it is mirrored in the non-cyclic IN word.

Telegram 2

The second telegram from the DP master also indicates a Write cycle, but the stamp number is now set to 2. The data byte would contain the parameter number for the parameter that is to be written to.

Bit	15	14	13	12	11	10	9	8	7	6	5	4	3	2	1	0
Value	0	X	X	X	0	0	1	0	0	0	0	0	1	0	1	1

Data word: 0x020B Stamp number = 2 Parameter number = 11

When the second telegram has been received and processed in the DP node, it is mirrored in the non-cyclic IN word.

Telegram 3

The third telegram from the DP master has the stamp number set to 3. The data bits contain the data high byte for the parameter being written to.

Bit	15	14	13	12	11	10	9	8	7	6	5	4	3	2	1	0
Value	0	X	X	X	0	0	1	1	0	0	0	0	1	0	1	1

Data word: 0x030B Stamp number = 3 Data high byte = 2816

When the first telegram has been received and processed in the DP node, it is mirrored in the non-cyclic IN word.

Telegram 4

The fourth telegram from the DP master has the stamp number set to 4. The data bits contain the data low byte for the parameter that is being written to.

Bit	15	14	13	12	11	10	9	8	7	6	5	4	3	2	1	0
Value	0	X	X	X	0	1	0	0	0	0	1	0	0	0	1	0

Data word: 0x0422 Stamp number = 4 Data low byte = 34

When the fourth telegram has been received and processed in the DP node, it will write the data (#18.11 = 2850) as transmitted. If the operation is successful, the ERROR bit is reset to 0.

If message was accepted OK, the telegram below is returned.

Bit	15	14	13	12	11	10	9	8	7	6	5	4	3	2	1	0
Value	0	0	X	X	0	1	0	0	X	X	X	X	X	X	X	X

Data word: 0x0400 stamp number = 4

If there was a problem with writing the data to the defined parameter, e.g. parameter is read only, does not exist, or data is out of range, the ERROR bit is set to 1.

Bit	15	14	13	12	11	10	9	8	7	6	5	4	3	2	1	0
Value	0	1	X	X	0	1	0	0	X	X	X	X	X	X	X	X

Data word: 0x4400 stamp number =4)

The non-cyclic data channel provides the controlling PLC with a method of reading from or writing to any parameter within the Drive. This channel can be used for uploading or downloading parameter sets for a particular node, allowing (with appropriate code) the PLC to detect a new or replacement node, and download the required parameter set.

7 Profibus-DP network configuration

7.1 Network data rate

The network data rate is automatically recognised by the UD73 and MD24. The following network data rates (in bits per second) are supported:

9.6 Kbps 19.2 Kbps 93.75 Kbps 187.5 Kbps 500 Kbps 1.5 Mbps

Identification number

A Profibus-DP slave will only accept data from the master controller if the Identification Number received from the master matches its own internal Identification Number.

The UD73 and MD24 have the Identification Number of 0x3345, so the data should be entered as:

Ident_number_high byte = 0x33.
Ident_number_low byte = 0x45.

7.2 Configuration telegram

When the network is initialised, the master will transmit the configuration telegram to each slave. If this does not match the configuration telegram within the slave (0xB7), the master will not be able to initialise the node correctly. Data consistency is required over all 8 bytes.

PLC configuration files

The configuration files listed below are supplied with the DPL Toolkit. The files can be found in the C:\MD29GUI\BIN directory in the ZIP file, PROFIDP.ZIP.

Filename	Description
ctc-3345.gsd	Generic PLC Profibus-DP configuration file
ct3345td.200	Siemens S5 PLC Profibus-DP configuration file compatible with Siemens V4.0 software
ct3345ax.200	Siemens S5 PLC Profibus-DP configuration file compatible with Siemens V5.0 software

8 Diagnostics

8.1 Determining if network is active on Unidrive

To determine if the Profibus-DP network is active from a DPL program, use #89.03. This parameter shows the total number of network cycles processed since power up.

The following example shows how to trip the Drive when the Profibus-DP network goes unhealthy.

```
CLOCK {  
new_cycles% = #89.03  
IF new_cycles% - old_cycles% = 0 THEN  
#10.38 = 60  
ENDIF  
old_cycles% = new_cycles%  
}
```

8.2 Cannot establish Profibus-DP connection

- Check your cabling and screens are connected correctly.
- Check that the network has been terminated, and the Drive supplying +5V and 0V for the terminating resistors is powered up.
- Check that the node address has been set correctly and only one node on the network has that particular address.
- Check the controller configuration settings.

8.3 Network not updating Drive parameters

- Check the mapping parameters have been programmed correctly.
- Store the parameters, and reset the UD70 or Mentor II to ensure that the changes take effect.
- Check that there are no mapping parameter conflicts, i.e. the analog and digital inputs are not trying to control the same parameters as the cyclic OUT channels. Parameter #20.50 shows the number of network cycles per second, if the network is actually running.

8.4 Unidrive trip codes

If certain errors occur, the Unidrive will trip and show the trip code in the upper window.

Trip Code	Error
tr52	This code indicates that the trip originated from the setting of bit 4 in the control Word.
tr56	The UD70 does not contain the correct operating system. Download the system file "IBSPROFI.SYS" from the MD29 Toolkit
tr57	An illegal operating system call has been made, e.g. WRNET. This is a CTNet command, and is not available with Profibus-DP.
tr60	This trip indicates that the number of messages received per second has dropped by 40%, indicating a network problem or network failure.

To reset the Unidrive using the Profibus-DP network, write a value of 100 to #10.38 using the non-cyclic data channel. (Refer to Unidrive Manual.)

8.5 Mentor II trip codes

Trip Code	Error
PdP	This trip indicates that no activity has been detected on the Profibus-DP network for over 100ms.
Pc2	This trip indicates that there is a fatal error on the MD24 card. This is most likely to be caused by a hardware failure.

To reset the Mentor II using the Profibus-DP network, set b11 of the control word to 1. This will cause the Mentor II to reset, equivalent to pressing the RESET button on the Mentor II itself. Note that the reset sequence on Mentor II takes approximately 3 seconds to complete.

9 General information

9.1 Option module code (Unidrive only)

The identification of the high speed communications option module can be read from #89.01. An integer number will be read back from this parameter.
Profibus-DP ID Code = 8.

9.2 Firmware version (Unidrive only)

The firmware inside the Profibus-DP module controls the information transfer between the UD70 and the Profibus-DP network Driver chip. The version installed in the option module can be read from #89.02.

The integer value returned by #89.02 should be converted to a hexadecimal value, and this value is in the form xyz. The version number is now in the form Vx.yz.

Example: If #89.02 = 514, the hex value will be 202, so the firmware version will be V2.02.

9.3 Number of network cycles (Unidrive only)

The number of Profibus-DP network cycles processed by the option module since power up is given in #89.03. This parameter can be used by a DPL program to generate a module trip if the built-in trip is not quick enough. (See Determining If network Is active on Unidrive)

Note

Parameters #89.01 to #89.03 are only available with V2.0.0 firmware and later, and V2.6.0 system files and later.

9.4 Profibus-DP timing

The cycle time of a Profibus-DP network running at 1.5 Mbaud containing UD73 and MD24 slaves can be approximately calculated as follows:

$$\text{Cycle time (ms)} = 0.63 * N$$

where:

N = number of nodes on the network.

Consider a network with 50 nodes and 4 words per node. There is a master controller node, which transmits to and receives from each node on every cycle. The network length is 50m. The theoretical minimum network update time is 31.50ms. The minimum update time for an identical network using Interbus-S is also given below.

Network	Min update time (ms)	Network data rate
Profibus-DP	31.50	1.5M
Interbus-S	10.95	500k

As can be seen from the above tables, Profibus-DP does not achieve as high update rate as Interbus-S. Profibus-DP uses node addresses, which take up additional bandwidth on the network. The Profibus-DP network uses only a single twisted pair, thus requiring all data to travel along the same cable.

The advantages of a Profibus-DP network are that the addressing structure allows for easy expansion of existing networks. Nodes can be added, and simply assigned the next available address. No changes are required to existing program, nor to the IN and OUT data arrays within the PLC. Another advantage is that multiple master controller configurations are permitted on the same network.

9.5 System propagation delays

The worst case propagation delay for a Profibus-DP network can be calculated by considering all delays through each stage of the system. Consider a system with 15 nodes, each node having 4 data words, and one node is a digital I/O module. What is the worst case delay that may be seen between a switch being operated at the I/O module to a change being reflected within a Drive??

The delays present within the system are:

I/O module update delay.

Profibus-DP network cycle time.

Profibus-DP module-to-Drive update time.

The I/O module will have a specified maximum update time, typically around 3ms. This is the period of time from the switch being changed to the buffer where the status word is read from being updated. For our example network, the minimum cycle time is $0.63 * 15 = 9.45\text{ms}$. A Profibus-DP cycle time of 10ms could be selected.

In the worst case, the buffer will change just after the node has read the buffer and sent the information to the controller. The change will not be seen by the PLC until the next Profibus-DP cycle, so there is a delay of up to 10ms. On the next cycle, the data is transferred to the PLC. When the cycle is complete, the PLC will see the change and modify the data for the target Drive. This adds another 10ms to the delay. On the third Profibus-DP cycle, data is transferred OUT to the Drive. Depending on the node's network address, there could be up to 9.45ms to the delay if the node has the last address in the cycle.

The delay due only to the network can be up to 9.45ms. Within the Control Techniques Profibus-DP module, it can take up to 2 ms for data to be transferred to the UD70.

For the example network,

worst case propagation delay would be $3 + 10 + 10 + 9.5 + 2 = 34.5\text{ms}$.

The worst case delays within the external nodes (I/O modules and Drives modules) are fixed; the variable part of the delay depends entirely on the network configuration. The longer the network cycle time, the higher the propagation delays will be.

10 Example application

10.1 System overview

Consider a drawing process as shown below. The material is unwound under constant tension, and passed between 3 sets of grip rolls. The material is drawn to the required thickness by introducing a ratio between each set of grip rolls. The machine operator has a control panel next to the machine, while the controlling PLC is located some 100m in another building.

A typical control system is shown, consisting of 2 * Mentor II Drives with tachometer feedback and MD24 cards, 3 * Unidrives with encoder feedback and UD70 with Profibus-DP interfaces, 1 * digital I/O module, 1 * analog I/O module and a controlling PLC. The operator panel connects to the digital and analog I/O modules to both input and display information to and from the PLC. This means that there is no need to run loads of control cables back to the PLC.

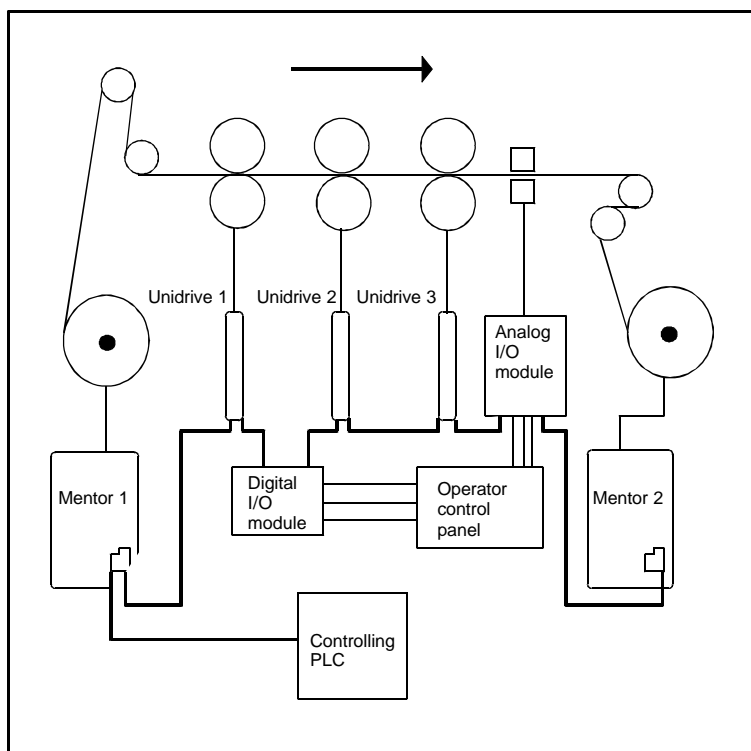

Unidrive 3 is the master Drive in the system. This receives the master speed reference from the PLC, and transmits the post-ramp speed reference back to the PLC. The post-ramp speed reference is scaled, and becomes the line speed reference for the Mentor II Drives.

Unidrive 2 is running in digital lock with Unidrive 3. It uses the encoder feedback from Unidrive 3 to generate its own speed reference, and stay locked to it. The draw ratio is calculated by the PLC, and the digital lock ratio is transmitted from the PLC. Unidrive 1 is locked to Unidrive 2, and also receives a digital lock ratio from the PLC.

The Mentor II Drives are running in torque control. Since Coiler software cannot be fitted to the MD24 cards, the Mentor IIs receive only a torque reference, with the Coiler calculations being performed in the PLC itself. The torque reference is changed as diameter changes, to maintain constant tension in the material.

Machine control is implemented using the digital and analog I/O modules. References are set using potentiometers into the analog module, and switches into the digital I/O module, and read by the PLC. Displays are controlled in the same manner, with the PLC writing to the digital and analog I/O modules, and the outputs being displayed using lamps and analog meters. The draw ratio is read in from 4 thumb wheel switches in BCD format, providing an accuracy of 4 decimal places.

Node	Device	Function
1	Mentor II 1	Unwind Drive, running in Coiler mode torque control.
2	Unidrive 1	Slave Drive running in digital lock with Unidrive 2. Digital lock ratio is passed over network.
3	Digital I/O	Digital inputs to read status of operator panel switches. Outputs are used to control status lamps and displays on operator panel.
4	Unidrive 2	Slave Drive running in digital lock with Unidrive 3 (Master Drive). Digital lock ratio is passed over network.
5	Unidrive 3	Master drive, running in speed control. Post-ramp reference is used as the line speed reference.
6	Analog I/O	Analog inputs to read the material depth transducer feedback signal, line speed, unwind and rewind tension references. Outputs control analog meters on the operator panel.
7	Mentor II 2	Rewind Drive, running in Coiler mode torque control.

10.2 IN cyclic data

To specify the network requirements, it is necessary to analyse each node, and identify the time critical data for each node. Data channels can then be assigned for each node. This will determine the requirements of the network, and the maximum theoretical performance.

Node	Device	Channel 1	Channel 2	Channel 3	
1	Mentor II 1	Status word	Motor speed	Current feedback	
2	Unidrive 1	Status word	Motor speed	Active current	
3	Digital I/O	Thumb wheel draw ratio	Control panel status		
4	Unidrive 2	Status word	Motor speed	Active current	
5	Unidrive 3	Status word	Line speed reference	Active current	
6	Mentor II 2	Status word	Motor speed	Current feedback	
7	Analog I/O	Master line speed reference	Material thickness	Unwind tension reference	Rewind tension reference

The IN data words are read from each node to provide information about the actual performance of the line. The motor speed feedback from each Mentor II allows the PLC to calculate the roll diameter relative to the initial reel diameter. The PLC can then calculate the actual roll diameter, allowing the line speed to be ramped up and down automatically as required when rolls need to be replaced.

10.3 OUT cyclic data

Node	Device	Channel 1	Channel 2	Channel 3	Channel 4
1	Mentor II 1	Control word	Torque reference		
2	Unidrive 1	Control word	Ratio 2	Maximum torque limit	
3	Digital I/O	Control panel display word	Control panel display word		
4	Unidrive 2	Control word	Ratio 1	Maximum torque limit	
5	Unidrive 3	Control word	Master line speed reference		
6	Mentor II 2	Control word	Torque reference		
7	Analog I/O	Material depth display	Scaled line speed	Scaled material unwind tension	Scaled material rewind tension

The control words are written to each Drive, thus making it a fully remote controlled system. For safety reasons, the ENABLE terminal on all Drives would have to be hard-wired into an emergency stop circuit. This would ensure that all Drives are disabled instantly if the emergency stop is pressed.

10.4 Network set-up

Node	OUT words	IN words	Configuration (inc. message word)
Mentor II 1	2	3	4
Unidrive 1	3	3	4
Digital I/O	2	2	2
Unidrive 2	3	3	4
Unidrive 3	2	3	4
Mentor II 2	2	3	4
Analog I/O	4	4	4

This gives a minimum network cycle time of approximately 4.41ms.

The actual network cycle time will depend upon the update time required, and the processing capability of the controlling PLC.

10.5 Digital I/O

The digital I/O module has 32 inputs and 32 outputs. Utilisation is as follows:

- | | |
|--------------|--|
| 4 * 4 inputs | draw ratio 1 in BCD format. Provides the overall draw ratio of 0.xxxx. |
| 16 inputs | inputs for run, jog, enable and emergency stop signals. |

The digital outputs are used to control display indication lamps, etc. on the operator's control panel.

10.6 Analog I/O

The analog I/O module has 4 input and 4 outputs. Utilisation is as follows:

- 1 input feedback from material thickness transducer
- 1 input master line speed reference
- 2 inputs material tension references for unwind and rewind sections

The analog outputs are scaled by the PLC to produce real unit readings on analog meters.

- 1 output material thickness, displayed in mm.
- 1 output actual line speed, displayed in metres/minute.
- 2 outputs material tension, displayed in Newtons.

11 Appendix

11.1 Profibus-DP network operation

A Profibus-DP network uses a single EIA RS485 shielded twisted pair, and links to nodes in a daisy chain type connection. All nodes are connected to the same twisted pair, and network termination must be provided at each end of the network.

The Object Dictionary must be set-up within the master PLC for each node on the network. This gives the node type, node address, number of data words and data type for that particular node, and is usually set up using the GSD file supplied. Each node must then be configured to have a unique node address on the network.

When communicating with a slave node, the master transmits the configuration data to it. This is the configuration data for that particular node, as set-up in the Object Directory in the master PLC. The slave compares this data with the its own internal set-up data. (NOTE: the configuration data is fixed internally for the Control Techniques Profibus-DP interfaces.) If both sets of data match, the slave replies to the master PLC and enters data mode.

Once the slave acknowledges that the configuration data is correct, the master transmits the Request frame, consisting of a header, the OUT data and a trailer. The OUT data consists of four 16 bit data words: 3 cyclic data channels and 1 non-cyclic channel. The slave node will respond with a similar message, transmitting the IN data back to the PLC. The IN data format is also four 16 bit words, with 3 cyclic channels and 1 non-cyclic channel.

Mapping information for each cyclic data channel is stored locally within the FLASH memory on the UD70, and is controlled by the UD70 operating system, IBSPROFI.SYS. This requires no addressing data to be sent by the controlling PLC, thus reducing the network transmission overheads.

When data transmission is complete, the slave relinquishes control of the comms line, and the master addresses the next node on the network. Once all nodes have been addressed, OUT data transferred and IN data read, the controller has completed a network cycle. The IN data array is now available within the PLC for re-calculating set-points for the process. Once all these calculations have been performed, the new set-points can be transferred to the OUT data array. The network cycle can be run again, and new data transferred to each node.

11.2 Error detection

Once data has been transmitted, the validity of the data is checked using the error code, which is also transmitted with the data words. If the data is valid, then it is written to the destination parameter. Error correction information is not transmitted, as data passing through the cyclic channels has a very limited lifetime (1 network cycle), and error correction data would take up additional network bandwidth. If the data is corrupted, it is not transferred to the Drive.

12 Quick reference

12.1 Set-up and mapping parameters

Function	Unidrive (Default)	Mentor II (Default)
Node Address	#20.05	#14.01
IN Channel 1 Mapping	#20.07 (Status word)	#11.01 (Status word)
IN Channel 2 Mapping	#20.03 (#2.01)	#11.02 (#3.02)
IN Channel 3 Mapping	#20.04 (#4.02)	#11.03 (#5.01)
OUT Channel 1 Mapping	#20.06 (Control word)	#11.04 (Control word)
OUT Channel 2 Mapping	#20.01 (#1.21)	#11.05 (#1.18)
OUT Channel 3 Mapping	#20.02 (#4.08)	#11.06 (#4.08)

12.2 General Drive functions

Action	Unidrive	Mentor II
Activate mapping changes	Set #MM.00 to 1070 and press the RESET button.	Press RESET button when the Drive is disabled.
Save and activate mapping changes	Set #17.19 to 1.	Set #MM.00 to 1 and press RESET.
Remote Drive reset	Set #10.38 to 100.	Set bit 11 of the control word to 1.

12.3 Control words

Bit	Unidrive – UD73		Mentor II – MD24	
	Parameter	Description	Parameter	Description
0	#6.15	Drive enable	#4.10	Current limit selector
1	#6.30	Sequencing bit 0	#1.11	Reference ON
2	#6.31	Sequencing bit 1	#1.12	Reverse selector
3	#6.32	Sequencing bit 2	#1.13	Inch selector
4	TRIP	Drive Trip (tr52)	#4.12	Torque Mode 0
5	#1.45	Preset select 0	#4.13	Torque Mode 1
6	#1.46	Preset select 1	#5.17	Inhibit firing
7	#18.31	Application bit	#2.02	Ramp enable
8	#18.32	Application bit	#15.21	Application bit
9	M0	Mask bit 0	#15.22	Application bit
10	M1	Mask bit 1	#15.23	Application bit
11	M2	Mask bit 2	RESET	Set to reset Drive
12	M3	Mask bit 3	#15.25	Application bit
13	#18.33	Application bit	#15.29	Application bit
14	M5	Mask bit 5	#15.31	Application bit
15	M6	Mask bit 6	VALID	VALID bit

12.4 Status words

Bit	Unidrive - UD73		Mentor II - MD24	
	Parameter	Description	Parameter	Description
0	#10.01	Drive healthy	#10.12	Drive healthy
1	#10.02	Drive running	#4.24	Taper threshold 1 exceeded
2	#10.03	Zero speed	#4.25	Taper threshold 2 exceeded
3	#10.04	Running at or below minimum speed	#10.13	I*t Alarm
4	#10.05	Below set speed	0	Not used
5	#10.06	At speed	#10.01	Forward velocity
6	#10.07	Above set speed	#10.02	Reverse Velocity
7	#10.08	Load reached	#10.03	Current limit
8	#10.09	In current limit	#10.04	Bridge 1 enabled
9	#10.10	Regenerating	#10.05	Bridge 2 enabled
10	#10.11	Dynamic brake active	0	Not used
11	#10.12	Dynamic brake alarm	#10.07	At speed
12	#10.13	Direction commanded	0	Not used
13	#10.14	Direction running	#10.09	Zero speed
14	#10.15	Mains Loss	#15.26	Application bit
15	X	Not used	ERROR	Set if there is an error on one of the cyclic channels

