

**GENERAL INFORMATION**

On the front is a bright and clear display (LCD with adjustable back-light). On the back are communication ports for connection to Automation Equipment (AE) and a PC (IBM or compatible computer), the power input connector, Tx and Rx LEDs, and configuration switches. This Terminal Interface Unit (TIU) supports a variety of AE. The operating system can also be downloaded through the PC port. This TIU supports up to 300 menu and sub-menu pages (password protection available). Each page can display up to eight embedded data items which include numeric, alphanumeric, timer, and bit status. Data registers, Timer and Counter pre-sets, and internal bits in the PLC may be edited. Also, display of status information and priority and view accepted active alarms are available. The unit can display live graphs and trends, a feature unique on an interface of this size. The TIU is configured with Windows-based software (part # SSP-2050-1003). The software package contains all of the supported protocols. There are available two non-standard features: 20mA current loop (please enquire) and a real-time clock (PN SSP-2050-0115). Both should be ordered at the time of purchase, factory refit is required for RTC.

**EQUIPMENT NEEDED:**

- a) Software (Part # SSP-2050-1003) including programming lead is available at modest cost.
- c) PC running Windows 95, 98 or NT4 with approximately 2 MB of free hard disk space.
- d) Serial cable from the CTIU110 to the Automation Equipment.

**DECLARATION OF CONFORMITY**

Distributor's Name: Control Techniques PLC, The Gro, Pool Road, Newtown, Powys, SY16 3BE, UK.

Declares that the Product Type: Terminal Interface Unit Model: CTIU110

Conforms to the following specifications:

- EN 55 022, Radiated and Conducted Emissions
- EN 61000-4-3 and ENV50141 Radiated and Conducted RF Immunity
- Year 2000 Compliant
- NEMA 4 / IP 65

Supplementary Information:

The above conformity only relates to the products in a stand-alone capacity. The products are used as part of a system and are therefore classified as a component. As a component, the products are prohibited by EC regulations to carry a CE Mark for EMC conformity. Static discharge tests only apply to normal operation of the keyboards via the front panel. We would stress that the use of our products within your system, while helping to ensure compliance of your system to the same directives, do not necessarily guarantee that compliance will be achieved. We would also like to point out that the interpretation of the law concerning CE marking and its application to sub-assemblies and components is open to

**TECHNICAL SUPPORT:**

Contact your local Control Techniques Drive Centre.

**LIMITED WARRANTY AND LIMITATION OF LIABILITY**

Control Techniques PLC. ("CT") warrants to the original purchaser that the CTIU110 distributed by CT is free from defects in material and workmanship under normal use and service. The obligation of CT under this warranty shall be limited to the repair or exchange of any part or parts which may prove defective under normal use and service within one (1) year from the date of purchase, such defect to be disclosed to the satisfaction of CT after examination by CT of the allegedly defective part or parts. THIS WARRANTY IS EXPRESSLY IN LIEU OF ALL OTHER WARRANTIES EXPRESSED OR IMPLIED INCLUDING THE WARRANTIES OF MERCHANTABILITY AND FITNESS FOR USE AND OF ALL OTHER OBLIGATIONS OR LIABILITIES AND CT NEITHER ASSUMES, NOR AUTHORIZES ANY OTHER PERSON TO ASSUME FOR CT, ANY OTHER LIABILITY IN CONNECTION WITH THE SALE OF THE CTIU110 OR CTIU110. THIS WARRANTY SHALL NOT APPLY TO THE CTIU110 OR ANY PART THEREOF WHICH HAS BEEN SUBJECT TO ACCIDENT, NEGLIGENCE, ALTERATION, ABUSE, OR MISUSE. CT MAKES NO WARRANTY WHATSOEVER IN RESPECT TO ACCESSORIES OR PARTS NOT SUPPLIED BY CT. THE TERM "ORIGINAL PURCHASER", AS USED IN THIS WARRANTY, SHALL BE DEEMED TO MEAN THAT PERSON FOR WHOM THE CTIU110 IS ORIGINALLY INSTALLED. THIS WARRANTY SHALL APPLY ONLY WITHIN THE BOUNDARIES OF THE CONTINENTAL UNITED STATES.

In no event, whether as a result of breach of contract, warranty, tort (including negligence) or otherwise, shall CT or its suppliers be liable of any special, consequential, incidental or penal damages including, but not limited to, loss of profit or revenues, loss of use of the products or any associated equipment, damage to associated equipment, cost of capital, cost of substitute products, facilities, services or replacement power, down time costs, or claims of original purchaser's customers for such damages.

To obtain warranty service, return the product to your distributor with a description of the problem, proof of purchase, post paid, insured and in a suitable package.

**FRONT VIEW**

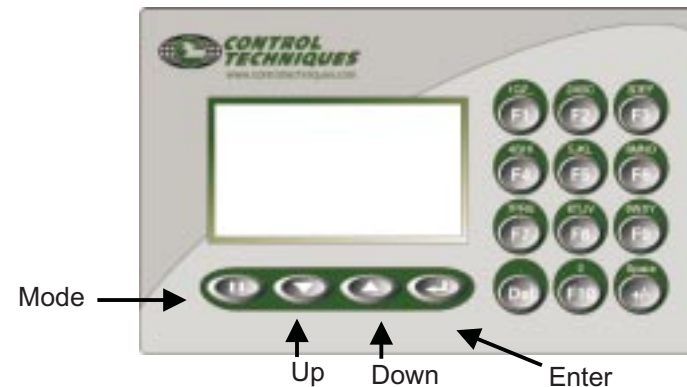

**REAR VIEW**

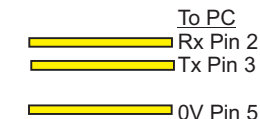

**SW1 Configuration Switches (RS-485)**

1. Pull-up
2. 120Ω terminator
3. Pull-down
4. Not used

**Note:** 1 and 3 must be used together.

**TECHNICAL SPECIFICATIONS**

Parameter	Conditions	Min.	Typical	Max.	Units
Input voltage (V <sub>i</sub> )		10	24	32	VDC
Typical power consumption	V <sub>i</sub> = 24VDC		130		mA
Inrush input current	V <sub>i</sub> = 24VDC for 4ms		260		mA
Operating temperature		0		50	°C
Storage temperature		-20		80	°C
Relative Humidity	(non-condensing)	5		85	%
Weight			470	500	g
Dimensions		172 x 105 x 38			mm

**BUTTON ACTIONS**

- MODE key selects data for editing OR exits from data editing  
UP key selects the previous menu page, sub-menu page, alarm, and increments data in editing
- DOWN key selects the next menu page, sub-menu, alarm, and decrements data in editing
- ENTER key sends data to the PLC, accepts alarms, and displays accepted alarms
- MODE & DOWN keys (pressed together) select sub-menu
- MODE & UP keys (pressed together) select parent menus

**CONTRAST ADJUSTMENT**

On menu page 1 (after the start-up screen), hold the ENTER key and press the UP or DOWN key to adjust the contrast. The contrast setting is stored and not lost after removing powering from the unit.

**SELF TESTS**

Power up the unit with the **UP** and **ENTER** keys pressed. The unit enters a self-test mode. The self-test consists of:

**CONTRAST BAND** - allows the user to set the lower and upper limits of contrast. Adjust the lower limit using the UP or DOWN key and press Enter when done. Do the same for the upper limit.

**WARNING:** Changes to the lower or upper limits may allow the user to set the contrast to a setting where the display may appear blank. It is recommended that the factory setting are used (Min 8A, Max FE).

**DISPLAY TEST** - continuously blinks all pixels on (black) to off. Look for any pixels stuck on or off. Press and hold the ENTER key for 2 seconds to exit.

**KEYBOARD TEST** - Press each key, \*\*\* appears above that key or a message is displayed for numeric keys. Check for keys indicating multiple presses or not reporting presses. Press and hold the ENTER key for 2 seconds to exit.

**RAM TEST** - segment 0000 and 1000. The segment 1000 test performs a base 3 repeating test. This test detects shorted address lines and damaged memory bits. The segment 0000 test performs a Read-Modify-Write test on each byte of RAM, detecting damaged memory bits. Press DONE to exit.

**SERIAL LOOPBACK** - Tests the PC and PLC ports. Plugs are required to loop-back the pins of a particular port as follows:

PC (J2) Short pins 2 to 3; RS-232 (J3) Short pins 6 to 8; RS-485 (J3) Short pins 2 to 4 and 3 to 5; and Current Loop Short pins 1 to 9, 10 to 11 and 7 to 12.

**CTIU110 CUTOUT DETAILS**

TOLERANCES ARE +/- 0.01" [0.3mm] UNLESS STATED OTHERWISE

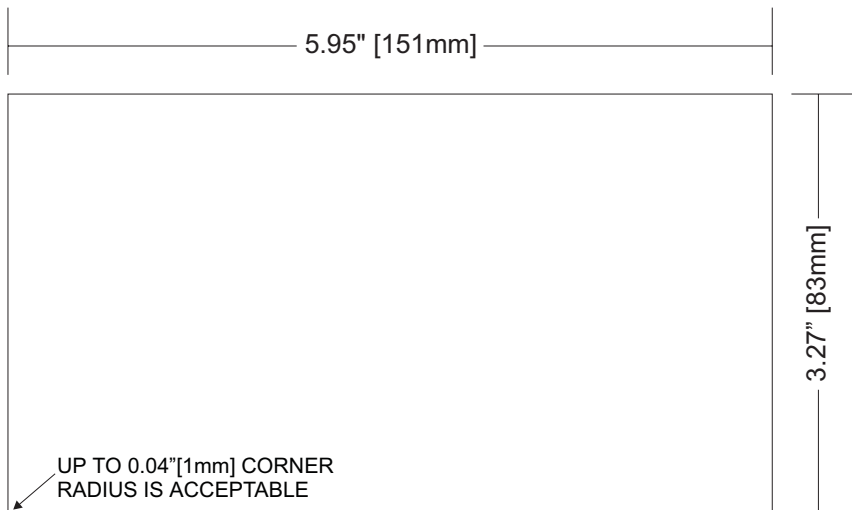

**NOTE:** In applications where IP Rating of the unit is not important, the gasket can be used as a template for marking out the cutout and hole centres.

**Drive or PLC Communications Connections**

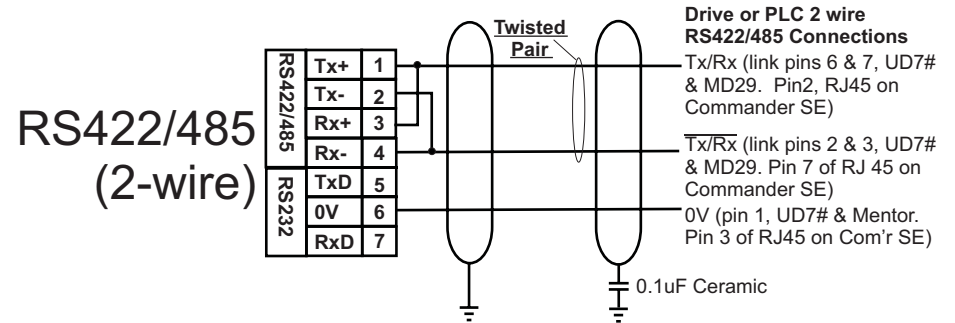
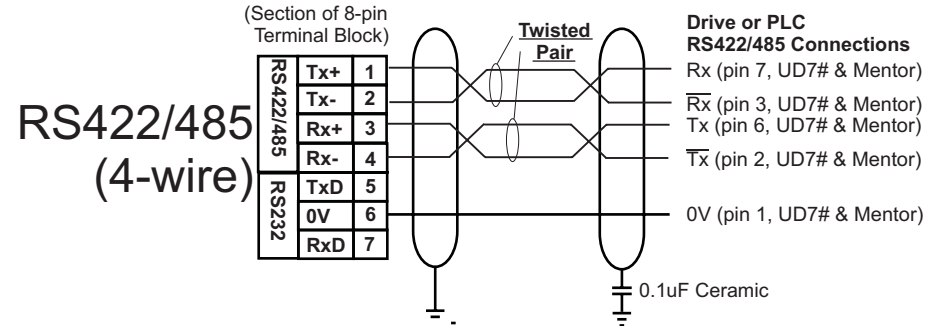
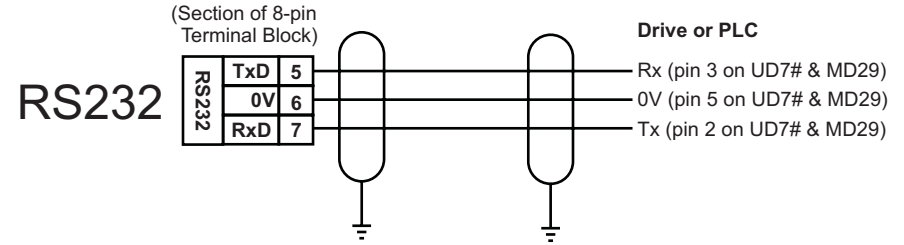

**Notes:**

1. Connection details are shown above for Control Techniques equipment. Connection and notation details used by other manufacturers for RS-422/485 vary widely! Refer to the relevant manual for details.
2. RS232 can be used with ANSI protocol and a UD71 RS232 connection OR MD29MON protocol and a UD70/MD29 RS232 connection (the programming port).

**Recommended Cable (RS-422/485):**

- a) Belden #8105, #9807 or #9832 - General Purpose
- b) Belden #8165 - Heavy Noise Environments

**20mA Loop**

A passive 4-20mA Current Loop communications option is available to special order from Control Techniques, please enquire for details