

GEARLESS Z2 - Z3

**A.C. drive
for elevators**

Installation and maintenance

GEARLESS Z2 - Z3

A.C. Drive for elevators

To ensure that the LEROY-SOMER motor you have just purchased is entirely satisfactory, it is essential to adhere to the following instructions.

IMPORTANT: Contact with energised or rotating parts may cause injury. Do not touch the housing of a motor that is in operation, as it can reach high temperatures.

REMINDER: Moving parts are painted yellow, except for the pulley grooves and the brake disk. Installation, servicing and maintenance must only be carried out by qualified personnel.

Failure to follow the instructions in this document, or to apply them correctly, releases the manufacturer from liability.

The product is covered by the warranty during the guarantee period as long as any partial or total dismantling has only been performed with the assistance of LEROY-SOMER (or its approval).

CAUTION: Check that the elevator car has been immobilised before performing any work on the motor or the brakes.



The magnetic field on the rotor may affect pacemakers.

The motor rotor contains a powerful magnetic field. This field may affect digital devices such as watches, mobile phones etc.

Assembly or maintenance of the rotor must not be carried out by people with pacemakers or any other implanted medical electronic device.

1 - RECEIPT

Checks:

- as soon as you receive the machine, check that the nameplate on the machine conforms to your order.
- inspect the machine as soon as it is received. If there is any damage that has been caused by transportation, contact the carrier in the usual way.

Model		AC GEARLESS		Weight of the Gearless	
Maximum permissible load on the pulley	Type : Z3	Serial N° : 000000 001	Motor rated current		
Motor rated voltage	Max sheave load : kg	Weight : kg	Motor rated power		
Motor rated speed	MOTOR				
Pick-up voltage	Nom voltage : V	Current : A	Phases : 3		
Holding voltage	Frequency : Hz	Duty cycle :	Nom power : kW		
	Speed : Rpm	Elec insulation : H	Protection :		
	BRAKE				
	Pick up voltage : VDC	Current : A	Inrush current		
	Holding voltage : VDC	Current : A	Holding current		
CE		TÜV	SP®	2103003/A	
LEROY SOMER		16015 ANGOULEME Cedex FRANCE		MADE IN FRANCE	

GEARLESS Z2 - Z3

A.C. Drive for elevators

2 - STORAGE

2.1 - Storage location

This location must be dry and protected from harsh weather conditions, cold (temperature above -15°C), frequent temperature variations (to prevent the risk of condensation), and free from vibration, dust and corrosive gases.

If there is any vibration in the storage area, it is advisable to rotate the driving pulley at least twice a month (the brakes are released by the manual release system).

In certain transport conditions the grooves of the driving pulley are protected by a special varnish. This varnish must not be removed during storage.

2.2 - Prolonged storage (> 3 months)

Place the machine in a sealed waterproof enclosure with a dehydrating sachet inside corresponding to the volume to be protected and the degree of humidity of the location.

3 - ENVIRONMENT

The rated characteristics are given for operation in a standard environment (see IEC 600034-5):

- altitude less than 1000 m,
- maximum humidity: 95%,
- temperature between 0 and 40°C .

Derating may be provided if special conditions are indicated at the time the equipment is ordered.

GEARLESS Z2 - Z3

A.C. Drive for elevators

4 - COMMISSIONING

BEFORE INSTALLATION

If the equipment has been stored for several months, it is essential to check the following:

- the cleanliness of the interior and that there is no condensation
- correct insulation between the phases and the earth terminal on the motor (minimum 100MΩ at 500 V D.C. for 60 seconds) after having disconnected all the electronic circuits if necessary.

WARNING: do not apply the megohmmeter to the terminals of the thermal sensors as this may damage them.

If the required value is not reached, dry using internal or external heating.

Drying using external heating

- place the motor in an oven at 70°C for at least 24 hours until the correct insulation is achieved. (100MΩ)
- Take care to increase the temperature gradually to clear the condensation.
- After drying, during the cooling phase, check the insulation value regularly, as it will initially tend to fall then rise.

Drying using internal heating

- Test to be carried out with the brakes released.
- Connect motor windings V and W in parallel in relation to U. (see drawing below)
- Read off the resistance between U and V//W.
- Apply a **low voltage** D.C. current to them (to obtain 10% of the rated current calculated using the resistances of the winding), increase the voltage until 50% of the rated current is reached.
- Maintain the power for 4 hours. The temperature of the motor should increase slightly.

CAUTION: The pulley will move slightly on power-up (angular setting of the rotor in relation to the stator).

Motor connection for drying the winding	
	Phase connection
Power supply (-)	U
Power supply (+)	V + W (serial)

4.1 - INSTALLATION

The installation must comply with the characteristics of the motor indicated on the nameplate (see section 1).

It must include electrical safety devices.

Check that the handling equipment (slings, etc.) are suitable for the weight of the machine.

Use the attachment points provided on the machine.

Check that the cables are correctly positioned so that they are not damaged.

Provide the necessary mechanical protection devices to prevent people working on the machine becoming caught or trapped by the pulley and/or the cables.

The motors must be installed in such a way that the cooling air (not too damp, dust-free, and containing no vapour or corrosive gas) circulates freely.

4.1.1 - Cleaning

- Release the brake using the manual release system.
- Remove the protective varnish from the pulley grooves.

CAUTION: Do not use abrasive equipment. Use only a cloth soaked in alcohol. Care must be taken not to get any alcohol or grease on the brake disk.

WARNING: use the alcohol in a well ventilated area.

Z2-Z3 Fabricated steel shield

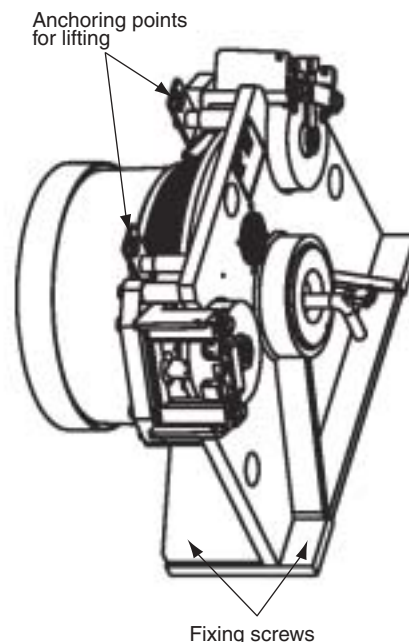

GEARLESS Z2 - Z3

A.C. Drive for elevators

Z2-Z3 Cast iron shield

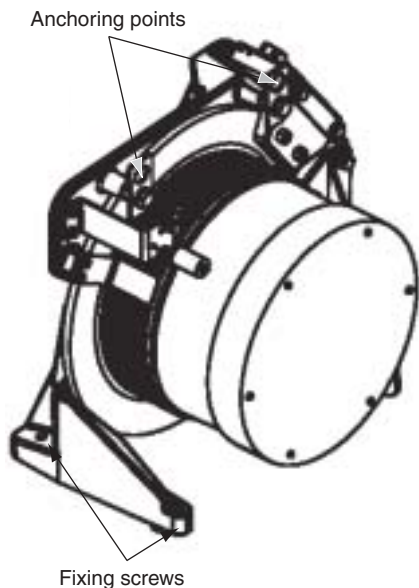

4.1.2 - Mechanical installation

- The GEARLESS machine must be installed on a chassis that is not subject to vibrations and must be secured. Cast iron shield = 4 M14 bolts and washers, fabricated steel shield = 4 M12 bolts and washers. The bolts must only be tightened when the cables, car, counterweights and driving pulley are perfectly aligned. Before installing the cables, check that the driving pulley can be rotated freely by hand when the brakes are released.

Z2-Z3 Protection

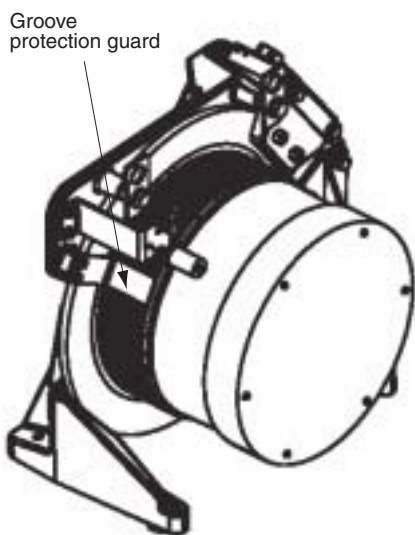

- Check that the cables are of the correct type for the pulley.
 - When the cables have been installed, adjust the distance between the cables and the protection then tighten the guards.

CAUTION: There is a high risk of jamming between the cables and the pulley.

4.2 - Wiring

- See the connection diagrams below.

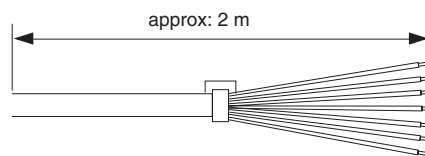

Fig. 1

Motor cable length 2 m

Phase output	
U	Phase 1
V	Phase 2
W	Phase 3
Ground/Earth	Green/Yellow

Length of thermal sensor cable 2 m

Phase output	
1	PTC
2	PTC

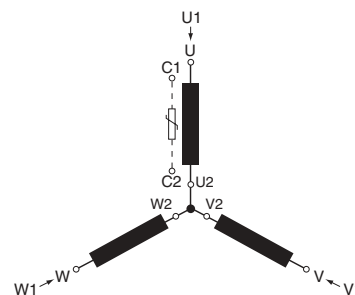

Fig. 2 - Motor connection

Brake wiring

Type	Colour	Marking
Brake power supply	Yellow	- BM
	Green	+ BM
Microswitch	White	CM1
	Brown	CM2

- Continuous supply (see name plate).
 - Connect the motor using cables of the correct cross-section (the cables and tags must be sized according to the current: see the table below). Particular care must be taken to tighten the nuts on the terminals. (Incorrect tightening may lead to the connections being damaged by overheating: see the diagram below.)

Rated current (A) per	9.5	12	16	25	34	40	46
Min cable section (mm ²)	1.5	1.5	2.5	4	6	10	10
AWG	15	15	13	11	9	7	0

This table is given for information only, and must under no circumstances be used in place of the current standards. The recommended cross-sections are given for a single-wire cable, with a maximum length of 10 m. Above this, line drops due to the length must be taken into account.

GEARLESS Z2 - Z3

A.C. Drive for elevators

CAUTION: It is the responsibility of the user to connect the motor in accordance with the current legislation and regulations in the country of use. This is particularly important as regards the size of the cables, the type and size of fuses, the earth or ground connection, powering down, acknowledging faults, insulation and protection against overcurrents.

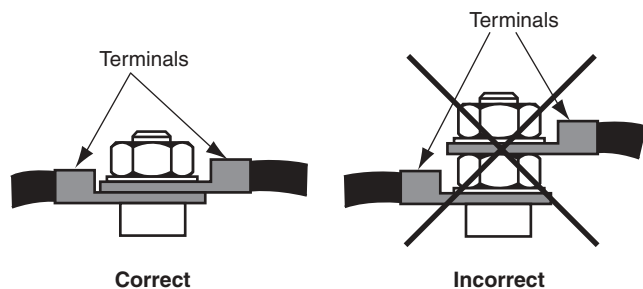

- Connect the power cables to terminals U1, V1 and W1, in accordance with IEC 600034-1 (see section 4.2 - fig. 1).
- Connect the thermal probe to the drive.
- Connect the motor ground to earth (see section 4.2 - fig. 1).
- Connect the brakes and the microswitches.
- Connect the encoder.

4.3 - Start-up

Check that the electric controls are correctly earthed before carrying out the first operation.

Start up the machine and check the following points:

- All the fixings and electrical connections must be correctly tightened.

After starting up, check:

- noise
- vibration
- operation of the buttons/switches
- also check the current and voltage on the machine while it is operating with the rated load.

- Encoder wiring (refer to the data sheet).

5 - MAINTENANCE/SERVICING

5.1 - After one month's operation

- Check that the screws and electrical connections are correctly tightened.
- Check the vibration. Check that there is no abnormal noise.
- Remove any traces of grease (if there are any) from the brake disks.
- Check that the noise level of the brakes is less than 60 dBA. If the observed noise level is above this value, inform LEROY-SOMER.
- If the brake wear needs to be checked: measure the brake air gap (it must be between 0.2 mm and 0.4 mm) using the checking method described in section 6. Note: this measurement will be used as a reference.

5.2 - Every year

- Check that the noise level of the brakes is less than 60 dBA. If it is not, adjust the brakes, as described in section 6.
- If the wear needs to be checked, ensure that the air gap is less than 0.5 mm. If it is not: check that the motor is not starting with the brakes engaged, otherwise contact LEROY-SOMER.

GEARLESS Z2 - Z3

A.C. Drive for elevators

6 - BRAKE ADJUSTMENT PROCEDURE

6.1 - Air gap adjustment tolerance

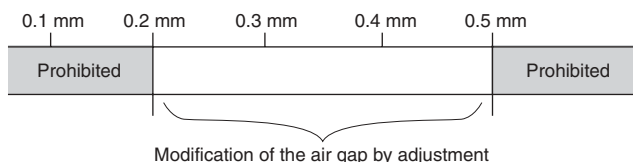

6.2 - Checking and adjusting the air gap (brakes de-energised)

6.2.1 - Check the brake air gap

1 - Measure the air gap using a set of adjustment shims at the points indicated (between the armature and the brake housing).

2 - The brake is correctly adjusted if the air gap is between 0.25 and 0.3 mm (factory setting).

6.2.2 - Adjusting the brake air gap

1 - Unlock and loosen the lock nuts on the brake adjustment screws.

2 - Insert two 0.25 mm adjustment shims in the air gap at the points indicated (in order to avoid the antivibration mounts and the springs).

3 - Re-tighten the adjustment screws alternately, so that the shims slide in easily.

4 - Tightly re-lock the lock nuts on the adjustment screws while firmly holding the adjustment screws.

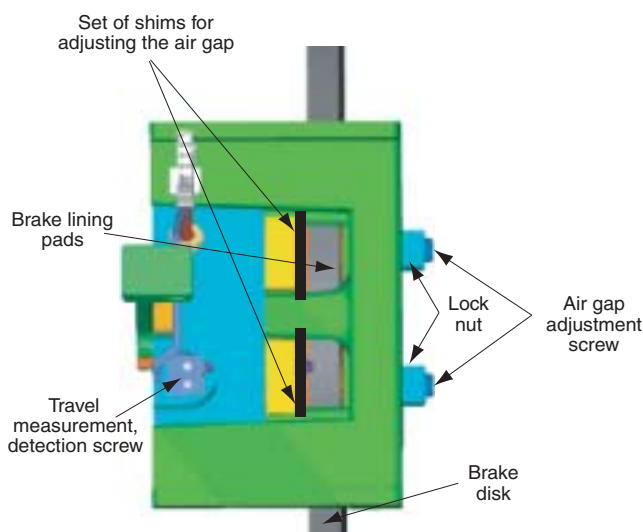

5 - After adjusting the air gap, the adjustment must be checked (section 6.3) and if necessary, the microswitches adjusted (section 6.4).

6.3 - Checking the adjustment of the air gap (with the brakes energised)

1 - Energise the brakes.

2 - Check the level of noise of each brake (no rattling) and ensure that the pulley rotates freely with the brakes released. If there is too much noise, re-adjust the brake using 0.20 mm shims.

3 - After this operation, it is essential to check the adjustment of the microswitches.

6.4 - Checking and adjusting the microswitches

- Each brake calliper has a microswitch.
- The microswitches are closed when the brake is engaged (active).
- The microswitches are wired in series (if there are several brakes).

1 - Check the microswitches using an ohmmeter.

2 - Check each microswitch in succession after short-circuiting the others. The check is carried out by activating the brake several times (releasing/engaging) at a minimum of 3 equidistant points during one complete rotation of the brake disk.

3 - The adjustment must be carried out with the brake energised (released).

- using the M6 grub screw (diagram below) and the lock nut, which is lightly tightened, adjust the screw, then retighten until it is firmly fastened. Then tighten one further half turn and lock the lock nut.

4 - Check sections 1 and 2

5 - Perform the same operation on the other microswitches

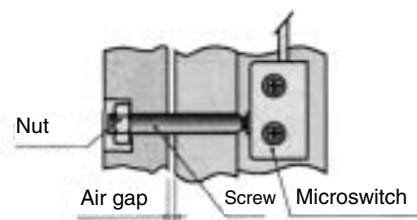

GEARLESS Z2 - Z3

A.C. Drive for elevators

7 - ORDERING SPARE PARTS

To ensure optimum after-sales service, the following information must be provided with each spare parts order:

- type and serial number of the motor

and for each spare part:

- Name and (or) reference number of the part

- quantity ordered.

For instant identification, please give the reference of the document used for the order (drawing number or manual). The type and serial number can be found on the nameplate of the motor.

Part names:

1 - Stator (not visible)	5 - Pulley	9 - Lifting rings
2 - Rotor	6 - Cable outlet	10 - Encoder (not visible)
3 - Pulley shaft	7 - Brake disk	11 - Brake switch
4 - Brake shield	8 - Brakes	12 - Motor cover

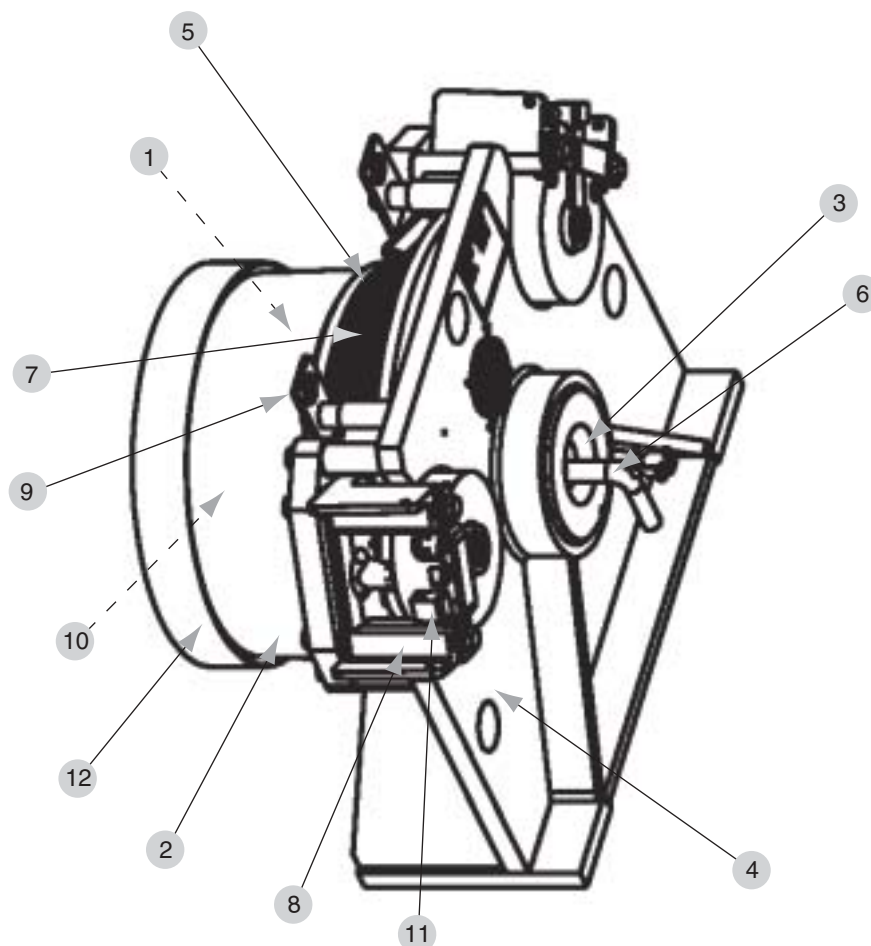

GEARLESS Z2 - Z3

A.C. Drive for elevators

GEARLESS Z2 - Z3

A.C. Drive for elevators

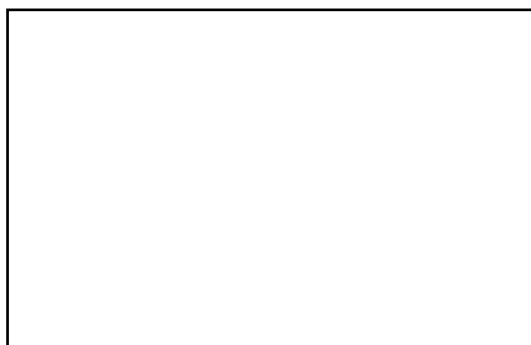

LEROY-SOMER 16015 ANGOULÊME CEDEX - FRANCE

RCS ANGOULÊME N° B 671 820 223
S.A. au capital de 62 779 000 €

www.leroy-somer.com