



Hydro Power Synchronous Generators



Power range 0.3 to 20 MW

LEROY-SOMER™

Nidec
All for dreams

Trusted Hydro Experts

Over **5 GW** installed capacity worldwide

Generators up to **20 MW**

60 years of experience

Over **750 projects**
completed worldwide over the last 20 years

ISO 9001 & 14001 certified

A trusted partner

As a historical and recognized player in the field of hydroelectric power generation, Nidec Leroy-Somer develops an approach of commitment and transparency, for your full confidence and satisfaction.

Throughout the project life, including design and manufacturing phases, our teams will help you meet technical and environmental specifications ensuring the perfect configuration and implementation.

Our key word: quality

Quality of products, supported by more than 100 years of know-how and continuous technical and innovative developments.

Quality in offering, with comprehensive and detailed proposals supported by a strong evaluation phase.

Quality in project management, with top-level technical and logistical support up to commercial operation and for long term service.



INNOVATION - RELIABLE - FLEXIBLE



Product range overview

A premium industrial & design expertise for your hydro projects.

Power	0.3 to 20 MW
Voltage	400 to 15,000 V
Rotation speed	300 to 1500 rpm / 50Hz 360 to 1800 rpm / 60Hz
Mountings	Vertical or horizontal
Cooling	IC01, IC21, IC31, IC81W (IEC 60034-6)
Insulation class	H (medium and high voltage included)
Temperature rise class	F or B
Excitation	Self-excited - Brushless rotating excitation
Regulation	Analog or digital Leroy-Somer AVR

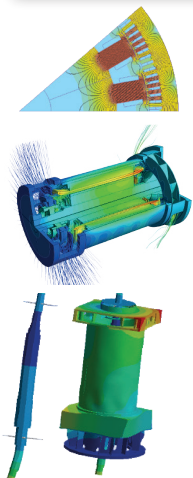

Design

Our highly skilled engineering teams focus on optimization and continuous improvement resulting in the highest performances available on the market (efficiencies, life span and mechanical behaviour).

For this purpose, we use the best computation tools relying on Finite element analysis (FEA) and 3D CAD design.

Close coordination work with turbine manufacturers can be performed in order to refine design and ensure a sound behaviour of the turbine-generator system on site.

The right solution

- Our products can be coupled to all turbine types, with particular attention to critical speed issues.
- Overhung runner assembly on extended shaft end, with turbine load withstanding.
- Rigid mechanical assembly coupled to dynamical balancing grade G1 (ISO 1940-1), aiming at low vibration levels in all operating conditions.
- Compact design aiming at reducing foundation costs.

Production

Our production site (Orléans, France), is equipped with state-of-the-art machinery.

We achieve product excellence and reach expected performances through controlled high quality components and processes at every step.

CNC plasma and laser cutting tools, precision form-wound winding, vacuum-pressure impregnation are some of the equipment operated by qualified and dedicated workers.

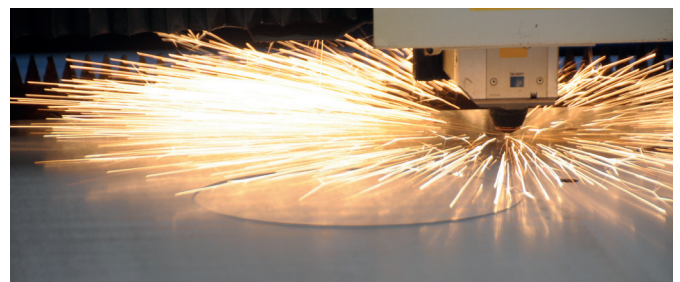

Custom solutions - Ease of integ

VERTICAL MOUNTING

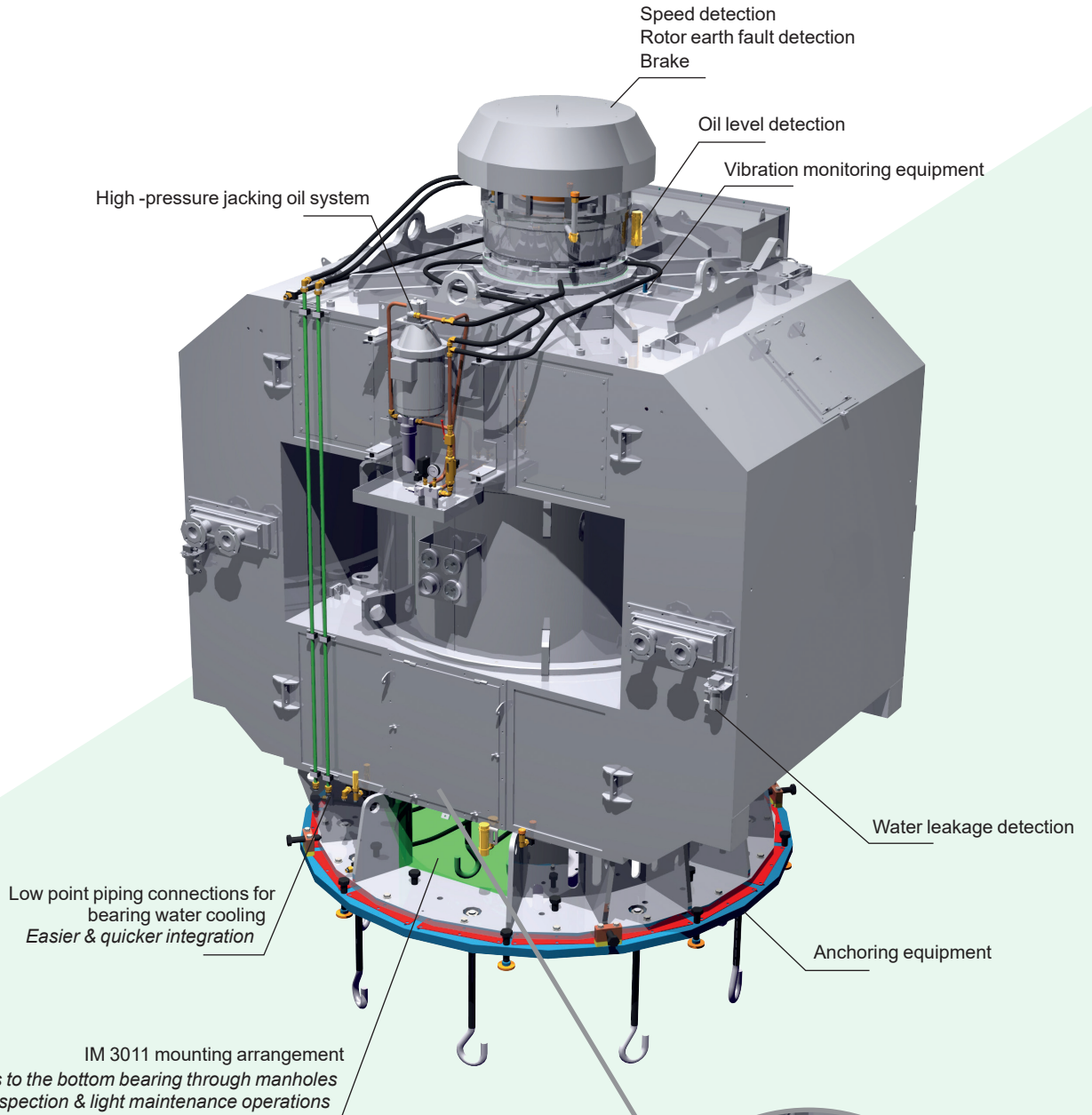

On-site handling

Combined rotor shaft locking & tilting equipment

For hard to reach sites and cramped machine rooms, we offer a wide range of solutions & devices that facilitate the alternator lifting & handling.

This tool, first introduced by us, allows safe transport/handling and enables transfer from horizontal to vertical position (and vice versa) on site with only one lifting device.

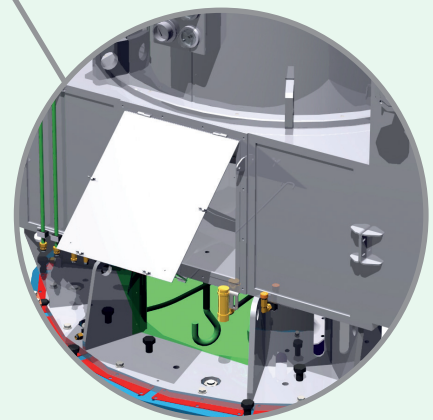
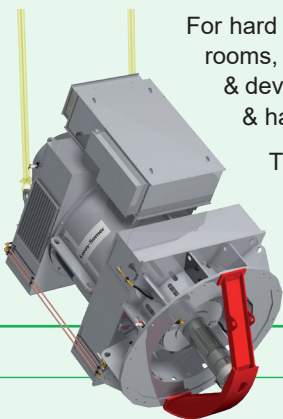

Fast opening louvers for powerhouse heating and/or in case of water supply failure

ration - Comprehensive option range

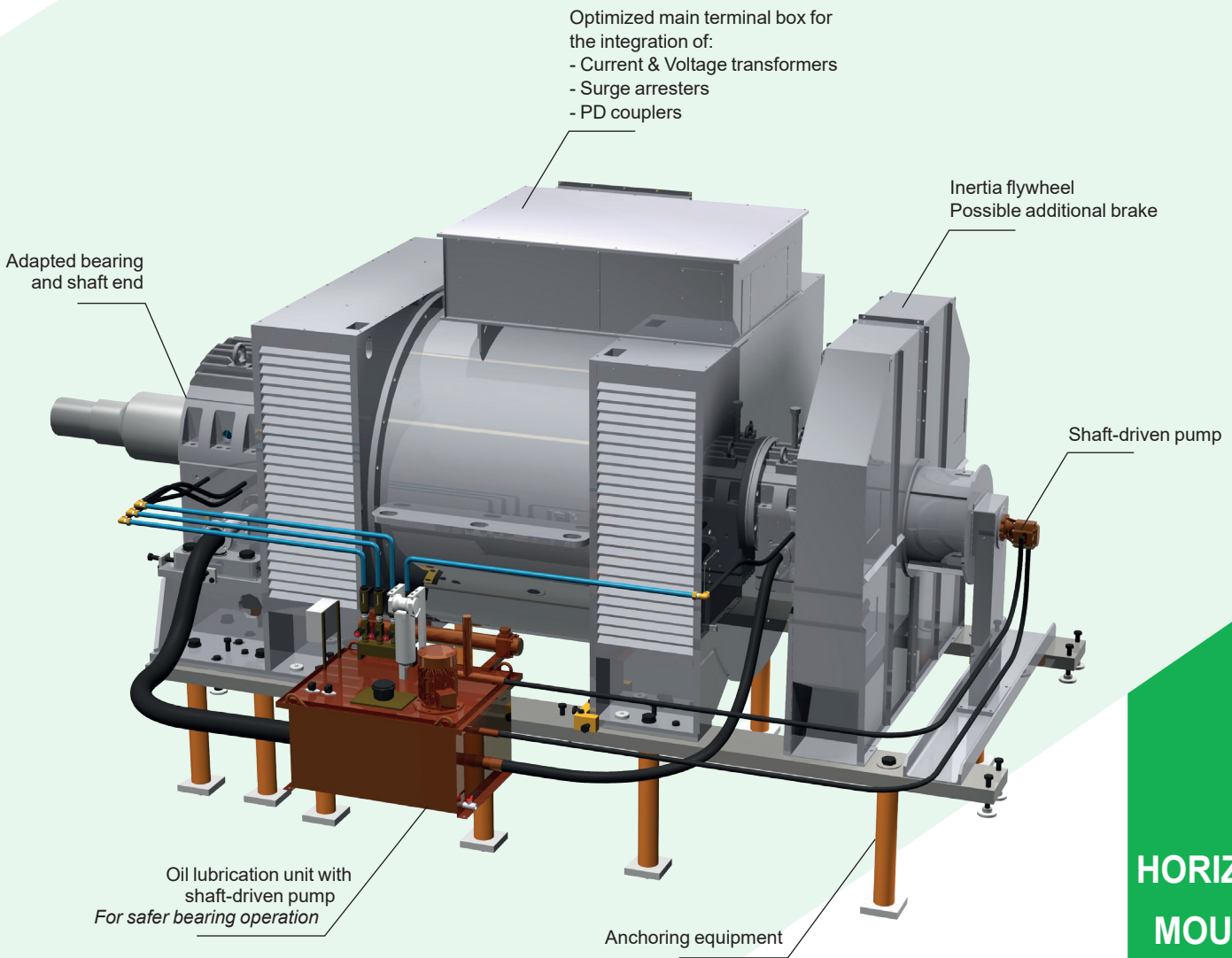

HORIZONTAL MOUNTING

Case study

Fredet-Bergès Hydro Plant, France

Reducing the acoustic footprint when inhabitants are just across the street:
problem solved 👍



Project ID

- 3.5 MW
- 750 rpm



To watch the video, scan the QR code or go to <http://lrsm.co/fredetbergeshydro>

Digital Static Excitation System

Transition your old generator static excitation to digital.

The Leroy-Somer Digital Static Excitation System can be installed on older generators.

It combines the proven technologies of a Leroy-Somer designed digital AVR like the D550 or D700 and a Leroy-Somer Mentor DC drive.

The drive provides a continuous direct excitation current up to 900A, controlled by the digital AVR with the following features:

- Automatic or manual voltage regulation
- Voltage equalization for grid connection
- Cos ϕ , Power Factor or kVAR regulation modes
- Advanced fault detection and data logging
- User-friendly touchscreen interface

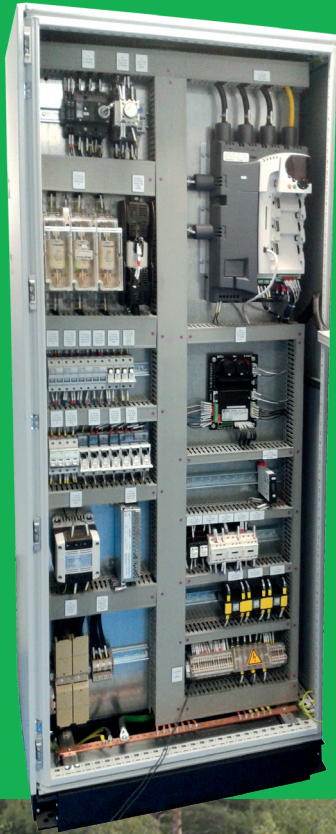

For more information,
scan the QR code
or go to:
<http://lrsm.co/hydro>

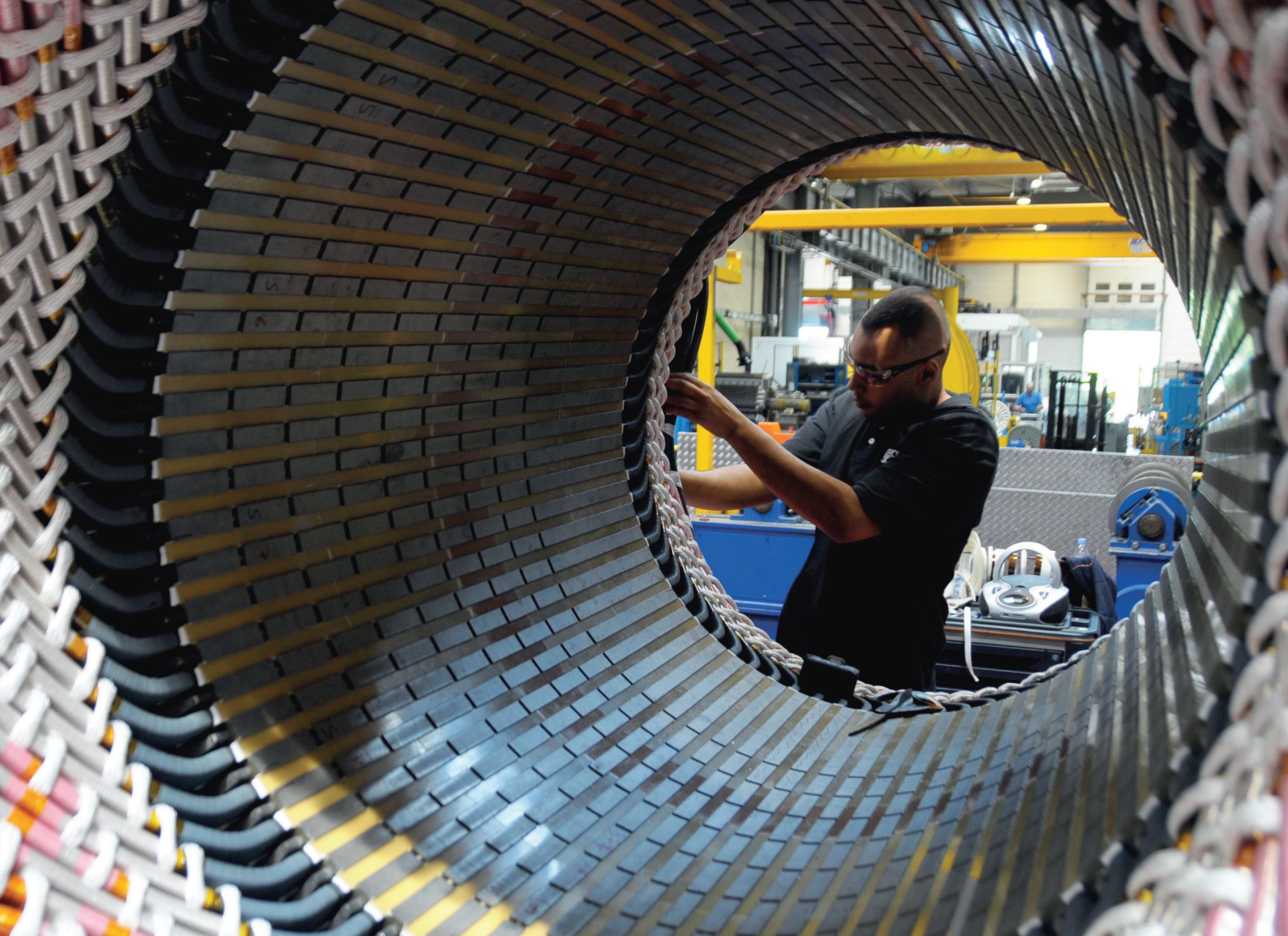

Support, Maintenance and Training

Services

We provide a complete range of services to support you from installation to commissioning and maintenance:

- On-site assembly when requested by site constraints
- Site erection, installation and commissioning
- On-site or in-house operations including repair, maintenance and diagnostic
- Long term service agreements with possible remote monitoring
- Advanced electrical and mechanical diagnostics, analysis and reports
- Parts center ensuring up-time requirements

Training

Our services and engineering teams have designed courses to address the specific challenges of hydro projects:

- Engineering companies: increase or refresh your knowledge, for specification write-up, better evaluation of proposals and comparison processes
- Operating companies: identify key topics to optimize daily and strategic operation activities, including scheduled controls, monitoring and maintenance, and get the most of Nidec Leroy-Somer generators

LEROY-SOMER[™]

www.leroy-somer.com/epg

Connect with us at:



Nidec
All for dreams

© 2024 Moteurs Leroy-Somer SAS. The information contained in this brochure is for guidance only and does not form part of any contract. The accuracy cannot be guaranteed as Moteurs Leroy-Somer SAS have an ongoing process of development and reserve the right to change the specification of their products without notice.

Moteurs Leroy-Somer SAS. Headquarters: Bd Marcellin Leroy, CS 10015, 16915 Angoulême Cedex 9, France. Share Capital: 32,239,235 €, RCS Angoulême 338 567 258.