

## TAL A40

### Low Voltage Alternators - 4 pole

Installation and maintenance

Three-phase 6 and 12-wire

Dedicated single-phase 4-wire

**LEROY-SOMER**<sup>™</sup>

***Nidec***  
All for dreams

# TAL A40

## Low Voltage Alternators - 4 pole

**This manual concerns the alternator which you have just purchased.  
We wish to draw your attention to the contents of this maintenance manual.**

### SAFETY MEASURES

Before using your machine for the first time, it is important to read the whole of this installation and maintenance manual.

All necessary operations and interventions on this machine must be performed by a qualified technician.

Our technical support service will be pleased to provide any additional information you may require.

The various operations described in this manual are accompanied by recommendations or symbols to alert the user to the potential risk of accidents. It is vital that you understand and take notice of the different warning symbols used.



**Warning symbol for an operation capable of damaging or destroying the machine or surrounding equipment.**



**Warning symbol for general danger to personnel.**



**Warning symbol for electrical danger to personnel.**

### SAFETY INSTRUCTIONS

We wish to draw your attention to the following 2 safety measures which must be complied with:

**a) During operation, do not allow anyone to stand in front of the air outlet guards, in case anything is ejected from them.**

**b) Do not allow children younger than 14 to go near the air outlet guards.**

A set of self-adhesive stickers depicting the various warning symbols is included with this maintenance manual. They should be positioned as shown in the drawing below once the machine has been fully installed.

### WARNING

**The alternators must not be put into service until the machines in which they are to be incorporated have been declared compliant with Directives EC and plus any other directives that may be applicable.**

**This manual is be given to the end user.**

**The range of electric alternators and their derivatives, manufactured by us or on our behalf, comply with the technical requirements of the customs Union directives (EAC).**

© - We reserve the right to modify the characteristics of its products at any time in order to incorporate the latest technological developments. The information contained in this document may therefore be changed without notice.

This document may not be reproduced in any form without prior authorization.

All brands and models have been registered and patents applied for.

# TAL A40

## Low Voltage Alternators - 4 pole

### CONTENTS

<b>1 - RECEIPT .....</b>	<b>4</b>
1.1 - Standards and safety measures .....	4
1.2 - Inspection.....	4
1.3 - Identification .....	4
1.4 - Storage .....	4
1.5 - Applications.....	4
1.6 - Usage restrictions.....	4
<b>2 - TECHNICAL CHARACTERISTICS .....</b>	<b>5</b>
2.1 - Electrical characteristics.....	5
2.2 - Mechanical characteristics .....	5
<b>3 - INSTALLATION.....</b>	<b>9</b>
3.1 - Assembly.....	9
3.2 - Checks prior to first use .....	10
3.3 - Terminal connection diagrams .....	10
3.4 - Commissioning.....	13
3.5 - Setting up .....	13
<b>4 - SERVICING - MAINTENANCE .....</b>	<b>14</b>
4.1 - Safety measures .....	14
4.2 - Routine maintenance.....	14
4.3 - Bearings.....	15
4.4 - Mechanical defects.....	15
4.5 - Electrical faults .....	16
4.6 - Dismantling, reassembly .....	18
4.7 - Table of characteristics .....	20
<b>5 - SPARE PARTS .....</b>	<b>22</b>
5.1 - First maintenance parts .....	22
5.2 - Technical support service .....	22
5.3 - Accessories.....	22
5.4 - Exploded view, parts list and tightening torque .....	23

### Disposal and recycling instructions

# TAL A40

## Low Voltage Alternators - 4 pole

### 1 - RECEIPT

#### 1.1 - Standards and safety measures

Our alternators comply with most international standards.

See the EC Declaration of Incorporation on the last page.

#### 1.2 - Inspection

On receipt of your alternator, check that it has not suffered any damage in transit. If there are obvious signs of knocks, contact the transporter (you may be able to claim on their insurance) and after a visual check, turn the machine by hand to detect any malfunction.

#### 1.3 - Identification

The alternator is identified by means of a nameplate fixed on the machine (see drawing).

Make sure that the nameplate on the machine conforms to your order.

So that you can identify your alternator quickly and accurately, we suggest you fill in its specifications on the nameplate below.

#### 1.4 - Storage

Prior to commissioning, machines should be stored :

- away from humidity (< 90%); after a long period of storage, check the machine insulation. To prevent the bearings from becoming marked, do not store in an environment with significant vibration.

#### 1.5 - Application

These alternators are mainly designed to produce electricity in the context of applications involving the use of generators.

#### 1.6 - Usage restrictions

Use of the machine is restricted to operating conditions (environment, speed, voltage, power, etc) compatible with the characteristics indicated on the nameplate.

# Nidec LEROY-SOMER™

Model	TAL		
S/N			Date
Enclosure	Protection		
Th. Class	Altitude		
Weight	PF		
AVR	Excitation		
Excitation 415 v / 40°C	No Load	Full Load	
DE bearing			
NDE bearing			

Freq.	Hz								
Speed	min <sup>-1</sup>								
Voltage	V								
Phase									
Connection									
Cont. BR 40°C	kVA								
	kW								
	A								
Std by. FR 27°C	kVA								
	kW								
	A								



IEC 60034 - 1 & 5  
ISO 8528 - 3  
NEMA MG1 - 32 & 33



LSA000-1-148 a

MOTEURS LEROY-SOMER  
2 BD MARCELLIN LEROY - 16000 ANGOULÊME - FRANCE

[www.leroy-somer.com](http://www.leroy-somer.com)

Made in Europe by Leroy-Somer

Scan the code or go to  
OEL.LS1.DO  
to check product data

# TAL A40

## Low Voltage Alternators - 4 pole

### 2 - TECHNICAL CHARACTERISTICS

#### 2.1 - Electrical characteristics

This machine is an alternator without sliprings and revolving field brushes, wound as "2/3 pitch"; 6 and 12-wire, with class H insulation and a field excitation system available in either SHUNT or AREP version.

##### • Electrical options

- Space heaters
- R791 interference suppression.

#### SHUNT dedicated single-phase 4-wire

#### 2.2 - Mechanical characteristics

- Steel frame
  - End shields in aluminum
  - Protected ball bearings, greased for life
- Mounting arrangement: single bearing with standard feet and SAE flanges/coupling discs
- Drip-proof machine, self-cooled

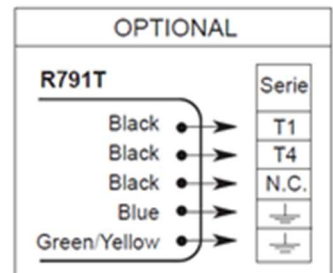
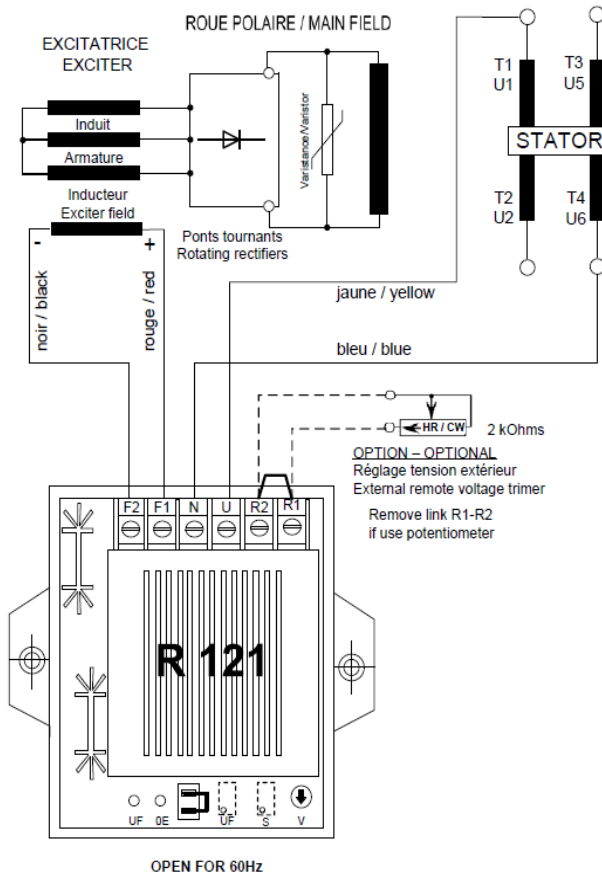

# TAL A40

## Low Voltage Alternators - 4 pole

### • SHUNT three-phase 12-wire

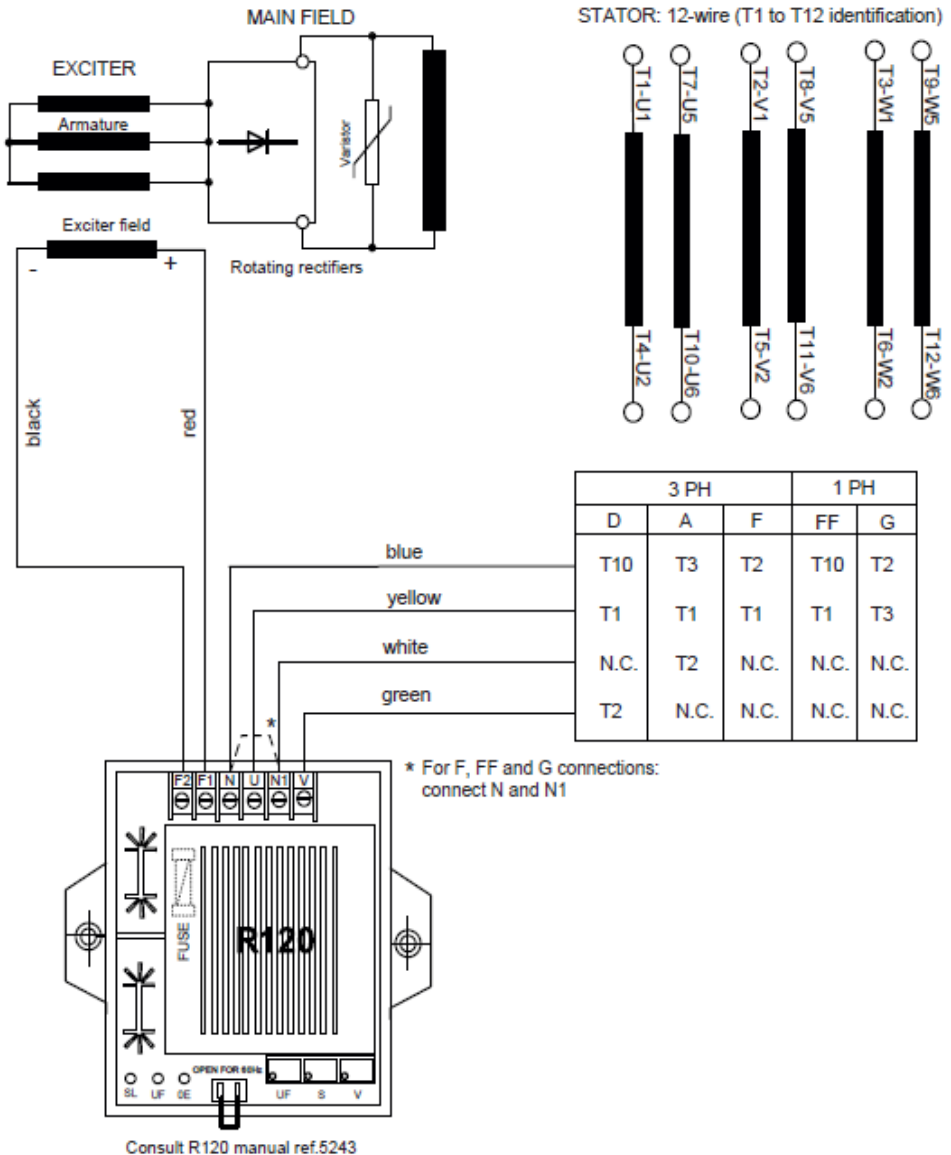

# TAL A40

## Low Voltage Alternators - 4 pole

• AREP+ three-phase 12

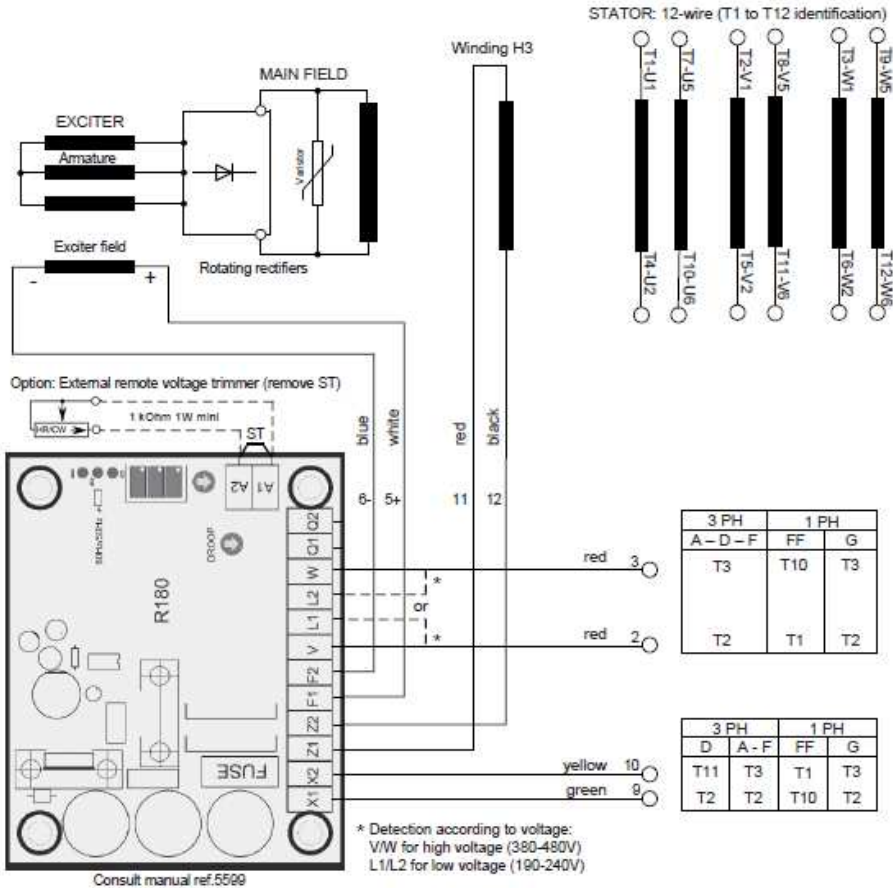

The PMG option is not available in TAL A40.

# TAL A40

## Low Voltage Alternators - 4 pole

### 3 - INSTALLATION

Personnel undertaking the various operations indicated in this section must wear personal protective equipment appropriate for mechanical and electrical hazards.

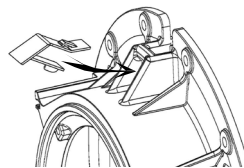

#### 3.1 - Assembly



All mechanical handling operations must be undertaken using suitable equipment and the machine must be horizontal. Check how much the machine weighs before choosing the lifting tool. During this operation, do not allow anyone to stand under the load.

##### • Handling

The generously-sized lifting eyes are for handling the alternator only. They must not be used to lift the genset. The choice of lifting hooks or handles should be determined by the shape of the lifting eyes. Choose a lifting system which respects the integrity and the environment of the machine.

During this operation, do not allow anyone to stand under the load.

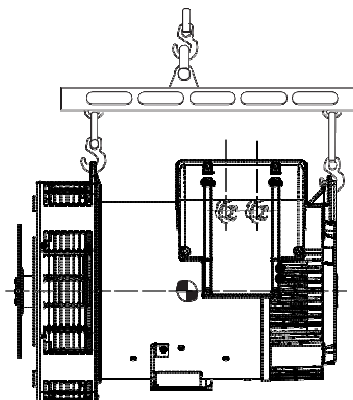

After handling the machine using the lifting ring, snap on the plastic cover provided in the maintenance manual wallet.

##### • Single-bearing coupling

Before coupling, check the compatibility between the alternator and the engine by performing:

- undertaking a torsional analysis of the transmission (alternators data are available on request),
- checking the dimensions of the flywheel and its housing, the flange, coupling discs and offset.

**WARNING**

When coupling the alternator to the prime mover, do not use the fan to turn the alternator or rotor.

The holes of the coupling discs should be aligned with the flywheel holes by cranking the engine.

Make sure the machine is securely bedded in position during coupling.

Check that there is lateral play on the crankshaft.

##### • Location

The room where the alternator is placed must be ventilated to ensure that the ambient temperature cannot exceed the data on the nameplate.



# TAL A40

## Low Voltage Alternators - 4 pole

### 3.2 - Checks prior to first use

#### • Electrical checks



**Under no circumstances should an alternator, new or otherwise, be operated if the insulation is less than 1 megohm for the stator and 100,000 ohms for the other windings.**

There are 2 possible methods for restoring the above minimum values.

- Dry out the machine for 24 hours in a drying oven at a temperature of 110 °C (without the regulator).
- Blow hot air into the air intake, having made sure that the machine is rotating with the exciter field disconnected.

#### **Note : Prolonged standstill**

In order to avoid these problems, we recommend the use of space heaters, as well as turning over the machine from time to time. Space heaters are only really effective if they are working continuously while the machine is stopped.

**WARNING**

**Ensure that the alternator has the degree of protection matching the defined environmental conditions.**

#### • Mechanical checks

Before starting the machine for the first time, check that:

- all fixing bolts are tight,
- the length of bolt and the tightening torque are correct,
- the cooling air is drawn in freely,
- the protective grills and housing are correctly in place,
- the standard direction of rotation is clockwise as seen from the drive end (phase rotation in order 1 - 2 - 3).

- the winding connection corresponds to the site operating voltage (see section 3.3).

### 3.3 - Terminal connection diagrams

To modify the connection, change the position of the stator cables on the terminals. The winding code is specified on the nameplate.



**Any intervention on the alternator terminals during reconnection or checks should be performed with the machine stopped.**

**In no case should the internal connections in the terminal box be subjected to stresses due to cables connected by the user.**

#### • SHUNT dedicated single-phase 4-wire

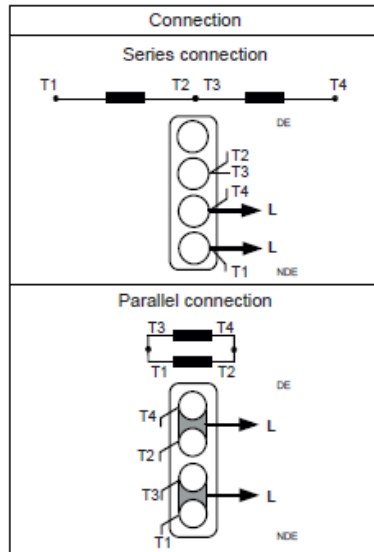

# TAL A40

## Low Voltage Alternators - 4 pole

### • SHUNT or AREP+ three-phase 12-wire

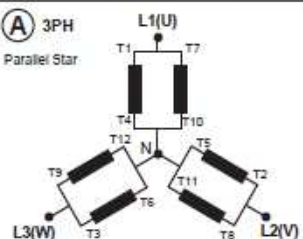
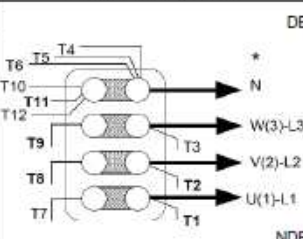
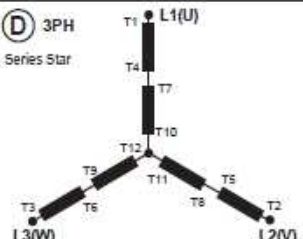
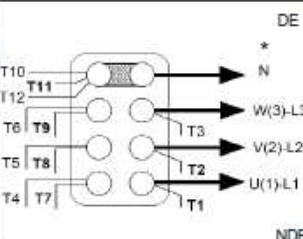
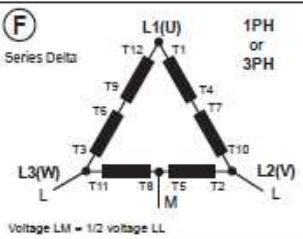
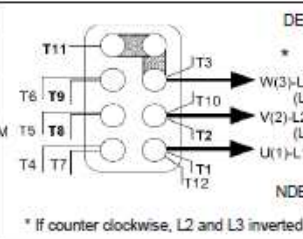
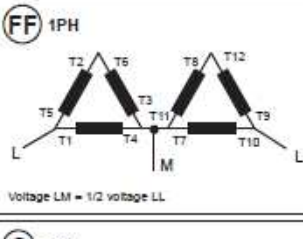
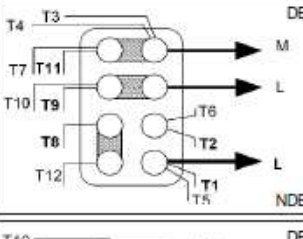
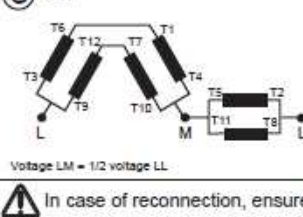
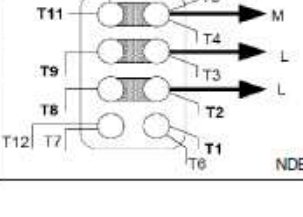
Connection codes		Voltage / Detection			Factory connection	
<b>(A)</b> 3PH Parallel Star 	Winding	50 Hz	60 Hz			DE
	6	190 - 208	190 - 240			* N W(3)-L3 V(2)-L2 U(1)-L1 NDE
	8	-	190 - 208			
<b>R120 :</b> N => T3, U => T1, N1 => T2, V => n.c. <b>R180 :</b> L1 => T2, L2 => T3						
<b>(D)</b> 3PH Series Star 	Winding	50 Hz	60 Hz			DE
	6	380 - 415	380 - 480			* N W(3)-L3 V(2)-L2 U(1)-L1 NDE
	8	-	380 - 416			
<b>R120 :</b> N => T10, U => T1, N1 => n.c., V => T2 <b>R180 :</b> V => T2, W => T3						
<b>(F)</b> Series Delta 1PH or 3PH 	Winding	50 Hz	60 Hz			DE
	6	220 - 240	220 - 240			* W(3)-L3 (L) V(2)-L2 (L) U(1)-L1 NDE
	8	-	220 - 240			
<b>R120 :</b> N => T2, U => T1, N1 => n.c., V => n.c. <b>R180 :</b> L1 => T2, L2 => T3						
Voltage LM = 1/2 voltage LL					* If counter clockwise, L2 and L3 inverted	
<b>(FF)</b> 1PH 	Winding	50 Hz	60 Hz			DE
	6	220 - 240	220 - 240			M L L NDE
	8	-	220 - 240			
<b>R120 :</b> N => T10, U => T1, N1 => n.c., V => n.c. <b>R180 :</b> L1 => T1, L2 => T10						
Voltage LM = 1/2 voltage LL						
<b>(G)</b> 1PH 	Winding	50 Hz	60 Hz			DE
	6	220 - 240	220 - 240			M L L NDE
	8	-	220 - 240			
<b>R120 :</b> N => T2, U => T3, N1 => n.c., V => n.c. <b>R180 :</b> L1 => T2, L2 => T3						
Voltage LM = 1/2 voltage LL						

**⚠** In case of reconnection, ensure that AVR voltage detection is correct !

# TAL A40

## Low Voltage Alternators - 4 pole

### • Connection checks



**Electrical installations must comply with the current legislation in force in the country of use.**

Check that:

- The residual circuit-breaker conforms to legislation on protection of personnel, in force in the country of use, and has been correctly installed on the alternator power output as close as possible to the alternator. (In this case, disconnect the wire of the interference suppression module linking the neutral).
- Any protection devices in place have not been tripped.
- If there is an external AVR, the connections between the alternator and the cabinet are made in accordance with the connection diagram.
- There is no short-circuit phase-phase or phase-neutral between the alternator output terminals and the generator set control cabinet (part of the circuit not protected by circuitbreakers or relays in the cabinet).
- The machine should be connected with the busbar separating the terminals as shown in the terminal connection diagram.



- The alternator earth terminal inside the terminal box is connected to the electrical earth circuit
  - The earth terminal is connected to the frame.
- The connections inside the terminal box must never be subjected to stress due to cables connected by the user.

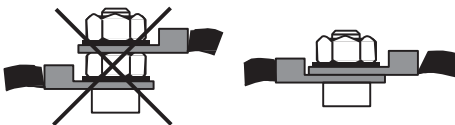

### 3.4 - Commissioning



**The machine can only be started up and used if the installation is in accordance with the regulations and instructions defined in this manual.**

The machine is tested and set up at the factory. When first used with no load, make sure that the drive speed is correct and stable (see the nameplate).

On application of the load, the machine should achieve its rated speed and voltage; however, in the event of abnormal operation, the machine setting can be altered (follow the adjustment procedure in section 3.5). If the machine still operates incorrectly, the cause of the malfunction must be located (see section 4.5).

### 3.5 - Setting up



**The various adjustments during tests must be made by a qualified engineer. Ensure that the drive speed specified on the nameplate is reached before commencing adjustment. After operational testing, replace all access panels or covers. The AVR is used to make any adjustments to the machine.**

# TAL A40

## Low Voltage Alternators - 4 pole

### 4 - SERVICING - MAINTENANCE

#### 4.1 - Safety measures

Servicing or troubleshooting must be carried out strictly in accordance with instructions so as to avoid the risk of accidents and to maintain the machine in its original state.



All such operations performed on the alternator should be undertaken by personnel trained in the commissioning, servicing and maintenance of electrical and mechanical components, who must wear personal protective equipment appropriate for mechanical and electrical hazards.

Before any intervention on the machine, ensure that it cannot be started by a manual or automatic system and that you have understood the operating principles of the system.



**Warning :** During and after running, the alternator will reach temperatures hot enough to cause injury, such as burns.

#### 4.2 - Routine maintenance

##### • Checks after start-up

After approximately 20 hours of operation, check that all fixing bolts on the machine are still tight, plus the general state of the machine and the various electrical connections in the installation.

##### • Electrical servicing

Commercially-available volatile degreasing agents can be used.

**WARNING**

**Do not use:** trichlorethylene, perchlorethylene, trichloroethane or any alkaline products.



**These operations must be performed at a cleaning station, equipped with a vacuum system that collects and flushes out the products used.**

The insulating components and the impregnation system are not at risk of damage from solvents. Avoid letting the cleaning product run into the slots.

Apply the product with a brush, sponging frequently to avoid accumulation in the housing. Dry the winding with a dry cloth. Let any traces evaporate before reassembling the machine.

##### • Mechanical servicing

**WARNING**

**Cleaning the machine using water or a highpressure washer is strictly prohibited. Any problems arising from such treatment are not covered by our warranty.**

Degreasing: Use a brush and detergent (suitable for paintwork).

Dusting: Use an air gun.

If the machine is fitted with air inlet and outlet filters, the maintenance personnel should clean them routinely at regular intervals. In the case of dry dust, the filter can be cleaned using compressed air and/or replaced if it is clogged.

After cleaning the alternator, it is essential to check the winding insulation (see sections 3.2 and 4.5).

# TAL A40

## Low Voltage Alternators - 4 pole

### 4.3 - Bearings

The bearings are permanently greased	Approximate life of the grease (depending on use) = 20,000 hours or 3 years.
--------------------------------------	--

### 4.4 - Mechanical defects

Fault		Action
Bearing	Excessive overheating of one or both bearings (bearing temperature 80°C above the ambient temperature)	<ul style="list-style-type: none"> <li>- If the bearing has turned blue or if the grease has turned black, change the bearing.</li> <li>- Bearing not fully locked (abnormal play in the bearing cage)</li> <li>- End shields incorrectly aligned</li> </ul>
Abnormal temperature	Excessive overheating of alternator frame (more than 40° C above the ambient temperature)	<ul style="list-style-type: none"> <li>- Air flow (inlet-outlet) partially clogged or hot air is being recycled from the alternator or engine</li> <li>- Alternator operating at too high a voltage (&gt;105% of Un on load)</li> <li>- Alternator overloaded</li> </ul>
Vibrations	Too much vibration	<ul style="list-style-type: none"> <li>- Misalignment (coupling)</li> <li>- Defective mounting or play in coupling</li> <li>- Rotor balancing fault (Engine - Alternator)</li> </ul>
	Excessive vibration and humming noise coming from the machine	<ul style="list-style-type: none"> <li>- Phase imbalance</li> <li>- Stator short-circuit</li> </ul>
Abnormal noise	Alternator damaged by a significant impact, followed by humming and vibration	<ul style="list-style-type: none"> <li>- System short-circuit</li> <li>- Misparalleling</li> </ul> <p>Possible consequences</p> <ul style="list-style-type: none"> <li>- Broken or damaged coupling</li> <li>- Broken or bent shaft end</li> <li>- Shifting and short-circuit of main field</li> <li>- Fan fractured or coming loose on shaft</li> <li>- Irreparable damage to rotating diodes/AVR, surge suppressor</li> </ul>

# TAL A40

## Low Voltage Alternators - 4 pole

### 4.5 - Electrical faults

Fault	Action	Effect	Check/Cause
No voltage at no load on start-up	Connect a new battery of 4 to 12 volts to terminals F1 and F2, respecting the polarity, for 2 to 3 seconds	The alternator builds up and its voltage is still correct when the battery is removed	- Lack of residual magnetism
		The alternator builds up but its voltage does not reach the rated value when the battery is removed	- Check the connection of the voltage reference to the AVR - Faulty diode - Armature short-circuit
		The alternator builds up but its voltage disappears when the battery is removed	- Faulty AVR - Field windings open circuit (check winding) - Main field winding open circuit (check the resistance)
Voltage too low	Check the drive speed	Correct speed	Check the AVR connections (possible AVR failure) - Field windings short-circuited - Rotating diodes burnt out - Main field winding short-circuited (check the resistance)
		Speed too low	Increase the drive speed (do not touch the AVR voltage pot. before running at the correct speed)
Voltage too high	Adjust AVR voltage potentiometer	Adjustment ineffective	Faulty AVR
Voltage oscillations	Adjust AVR stability potentiometer		- Check the speed : possibility of cyclic irregularity - Loose connections - Faulty AVR - Speed too low when on load
Voltage correct at no load and too low when on load (*)	Run at no load and check the voltage between F1 et F2 on the AVR	Voltage between F1 and F2 SHUNT < 6V - AREP < 10V	- Check the speed
		Voltage between F1 and F2 SHUNT > 10V - AREP > 15V	- Faulty rotating diodes - Short-circuit in the main field (check the resistance) - Faulty exciter armature (check the resistance)
(*) Warning : During single-phase operation, check that the sensing wires from the AVR are connected to the correct output terminals.			
Voltage disappears during operation	Check the AVR, the surge suppressor, the rotating diodes, and replace any defective components	The voltage does not return to the rated value	- Exciter winding open circuit - Faulty exciter armature - Faulty AVR - Main field open circuit or short-circuited
(**) Warning : The AVR internal protection may cut in (overload lost connection, short circuit).			

# TAL A40

## Low Voltage Alternators - 4 pole

### • Checking the winding

You can check the winding insulation by performing a high voltage test. In this case, you must disconnect all AVR wires.

### WARNING

conditions is not covered by our warranty.

### • Checking the diode bridge

A diode in good working order should allow the current to flow only in the anode-to-cathode direction.

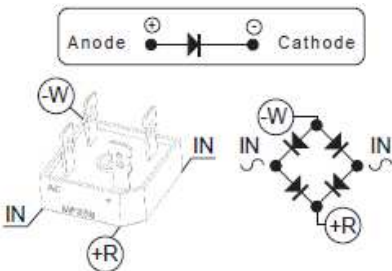

### • Checking the windings and rotating diodes using separate excitation



During this procedure, make sure that the alternator is disconnected from any external load and inspect the terminal box to check that the connections are fully tightened.

- 1) Stop the unit, disconnect and isolate the AVR wires.
- 2) There are two ways of creating an assembly with separate excitation.

**Assembly A:** Connect a 12 V battery in series with a rheostat of approximately 50 ohms - 300 W and a diode on both exciter field wires (5+) and (6-).

ASSEMBLY A

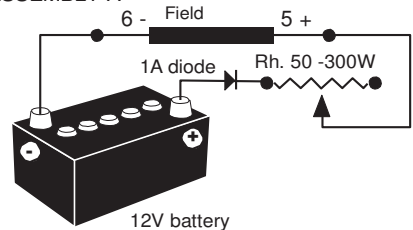

**Assembly B:** Connect a “Variac” variable power supply and a diode bridge on both exciter field wires (5+) and (6-).

Both these systems should have characteristics which are compatible with the field excitation power of the machine (see the nameplate).

3) Run the unit at its rated speed.

4) Gradually increase the exciter field current by adjusting the rheostat or the variac and measure the output voltages on L1 - L2 - L3, checking the excitation voltage and current at no load (see the machine nameplate or ask for the factory test report). When the output voltage is at its rated value and balanced within 1% for the rated excitation level, the machine is in good working order. The fault therefore comes from the AVR or its associated wiring (ie. sensing, auxiliary windings).

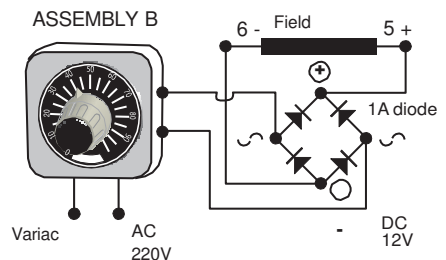

# TAL A40

## Low Voltage Alternators - 4 pole

### 4.6 - Dismantling, reassembly

#### WARNING

During the warranty period. This operation should only be carried out in an approved workshop or in our factory. otherwise the warranty may be invalidated.

Whilst being handled, the machine should remain horizontal (rotor not locked in position). Check how much the alternator weighs before choosing the lifting method.

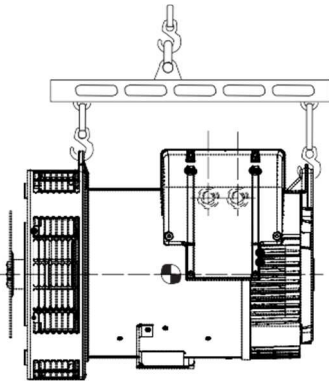

#### • Tools required

To fully dismantle the machine, we recommend using the tools listed below:

- 1 ratchet spanner + extension
- 1 torque wrench
- 1 set of flat spanners: 8 mm, 10 mm, 12 mm
- 1 socket set: 8, 10, 13 mm
- 1 socket TORX bit T20, T30
- 1 puller (eg. Facom: U35, U32/350)

#### • Bolt tightening torque

See section 5.4.



The bolts for fixing the feet on the housing and immobilising the stator must not be removed (bolt of the stator lower).

#### • Access to connections and the regulation system

The terminals and AVR are accessed directly by removing the terminal box lid (41).

#### • Accessing, checking and replacing the diode bridge

##### Dismantling

- Remove the terminal box lid [41].
- Cut the fixing clamps of the exciter cables, remove the connector from the exciter.
- Remove the 4 nuts on the tie rods.
- Remove the NDE shield [36] using a puller: eg. U.32 - 350 (Facom).
- Unsolder the connections.
- Check the bridge using an ohmmeter or a battery lamp.

##### Reassembly

- Replace the bridges, respecting the polarity.
- Resolder the connections.
- Fit a new O ring seal in the shield.
- Refit the NDE shield and pass the bundle of wires between the top bars of the shield.
- Replace the fixing clamps on the cables.
- Replace the terminal box lid [48].

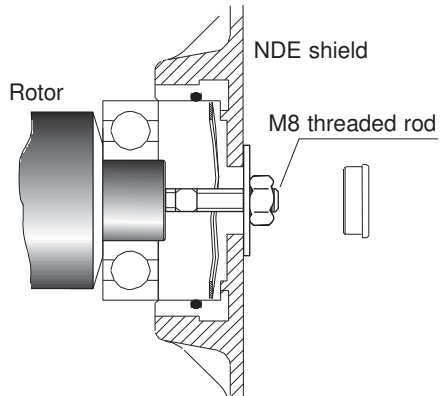



# TAL 040

## Low Voltage Alternators - 4 pole

### • Replacing the NDE bearing on single bearing machines

#### Dismantling

- Remove the NDE shield [36].
- Remove the ball bearing [70] using a bolt puller.

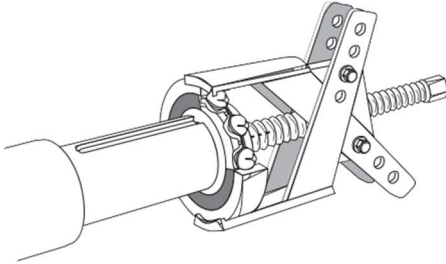

#### Reassembly

- Heat the inner slipping of a new bearing by induction or in a drying oven at 80 °C (do not use an oil bath) and fit it to the alternator.
- Place the preloading wavy washer [79] in the flange and fit a new O ring seal [349].
- Replace the NDE bracket [36].

### • Accessing the main field and stator

#### Dismantling

Follow the procedure for dismantling bearings.

- Remove the coupling discs (single bearing alternator) and insert a tube of the corresponding diameter on the shaft end or a support made according the following bellow.

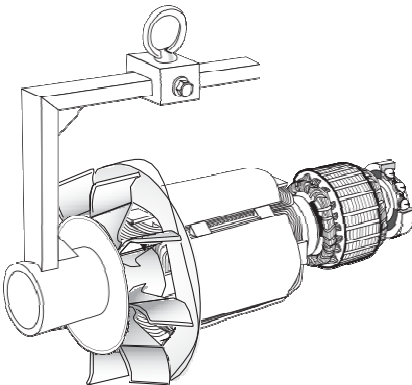

- Rest the rotor on one of its poles. then slide it out. Use the tube as a lever arm to assist dismantling.

- After extraction, be careful with the fan. It is necessary to replace the fan in case of disassembling.

- After extracting the rotor, be careful not to damage the fan and place the revolving field on special V-blocks.

**NOTE: If intervention is required on the main field (rewinding, replacement of components), the rotor assembly must be rebalanced.**

#### Reassembly

- Follow the dismantling procedure in reverse order.

Take care not to knock the windings when refitting the rotor in the stator.

If you replace the fan, respect the assembly guide according the following bellow. Use a tube and a bolt.

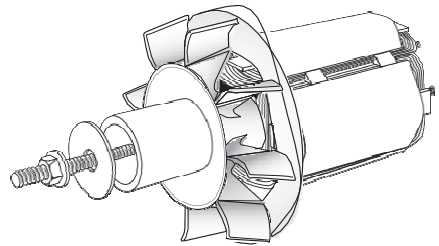

Follow the procedure for reassembling the bearings.

# TAL A40

## Low Voltage Alternators - 4 pole

### 4.7- Table of characteristics

Table of average values:

Alternator-4 pole-50 Hz-no. 6 (12-wire)

The voltage and current values are given for no-load operation and operation at rated load with separate field excitation. All values are given to  $\pm 10\%$  (for exact values, consult the test report) and are subject to change without prior warning.

#### • Three-phase: 4-pole

#### SHUNT and AREP +excitation

#### 12-wire Resistances at 20 °C

( $\Omega$ )

Type	L/N stator	Rotor	Field coil	Armature
C	0,776	3,050	14,1	1.7
D	0,605	3,280	14,1	1.7
E	0,467	3,550	14,1	1.7
F	0,421	3,700	14,1	1.7
G	0,274	4,400	14,1	1.7

#### Dedicated single-phase M: 4-pole

#### SHUNT excitation

#### Resistances at 20 °C ( $\Omega$ ) - Series

#### Connection

Type	Stator L/N	Rotor	Exciter field	Exciter armature
C	0.149	2.96	12.33	1.64
C1	0.114	3.24	12.32	1.64
D	0.097	3.45	12.33	1.64
E	0.081	3.77	12.33	1.64
F	0.068	4.31	12.33	1.64

# TAL A40

## Low Voltage Alternators - 4 pole

### Resistance of AREP+ windings at 20 °C (Ω)

Type	Z1, Z2 auxiliary windings
C	0,375
D	0,311
E	0,326
F	0,356
G	0,330

### • Table of weights

(values given for information only)

#### Three-phase: SHUNT/AREP+ 12-wire

Type	Total weight (kg)	Rotor (kg)
C	85	30
D	90	30
E	100	35
F	105	35

#### Dedicated single-phase M: SHUNT

Type	Total weight (kg)	Rotor (kg)
C	73	27
C1	80	29
D	87	31
E	92	33
F	102	36

# TAL A40

## Low Voltage Alternators - 4 pole

### 5 - SPARE PARTS

#### 5.1 - First maintenance parts

Emergency repair kits are available as an option.

They contain the following items:

<b>Single bearing kit</b>	<b>Consult factory</b>
Non drive end bearing Preloading (wavy) washer	
<b>Diode bridge with integrated varistor</b>	<b>Consult factory</b>
<b>Diode bridge</b>	<b>Consult factory</b>



**After operational testing, it is essential to replace all access panels or covers.**

#### 5.3 - Accessories

##### • Space heater for use when stopped

The space heater must run as soon as the alternator stops. It is installed at the rear of the machine. Its standard power is 60W with 230V or 60W with 127V on request.



**Warning: the power supply is present when the machine has stopped.**

#### 5.2 - Technical support service

Our technical support service will be pleased to provide any additional information you may require.

For all spare parts orders or technical support requests, send your request to [service.epg@leroy-somer.com](mailto:service.epg@leroy-somer.com) or your nearest contact, whom you will find at [www.lersm.co/support](http://www.lersm.co/support) indicating the complete type of machine, its number and the information indicated on the nameplate.

Part numbers should be identified from the exploded views and their description from the parts list.

To ensure that our products operate correctly and safely, we recommend the use of original manufacturer spare parts.

In the event of failure to comply with this advice, the manufacturer cannot be held responsible for any damage.

# TAL A40

## Low Voltage Alternators - 4 pole

### 5.4 - Exploded view, parts list and tightening torque

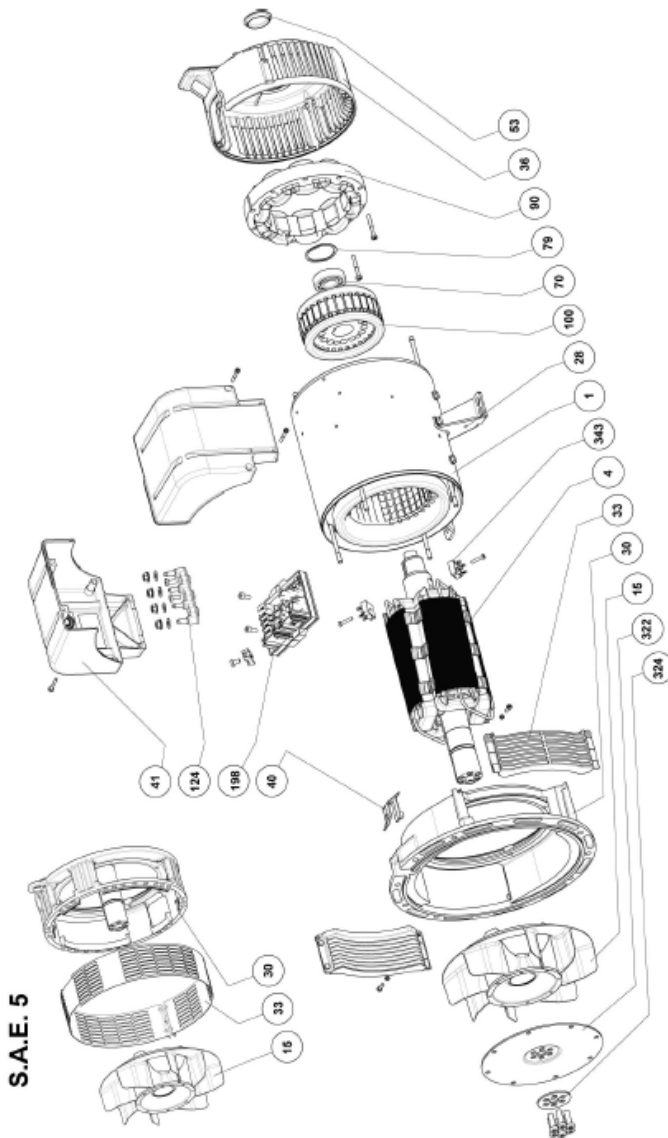

# TAL A40

## Low Voltage Alternators - 4 pole

Ref.	Qty	Description	Bolt Ø	Torque N.m	Ref.	Qty	Description	Bolt Ø	Torque N.m
1	1	Stator assembly	-	-	70	1	Non drive end (NDE) bearing	-	-
4	1	Rotor assembly	-	-	79	1	Preloading (wavy) washer	-	-
15	1	Fan	M5	4	90	1	Exciter field (stator)	M6	10
28	1	Earth terminal	M6	10	91	4	Fixing bolts	M6	10
30	1	Drive end (DE) shield	-	-	100	1	Exciter armature (rotor)	-	-
33	1/2	Protective guard	M5	4	124	1	Terminal block	-	-
36	1	Non drive end (NDE) shield	-	-	198	1	Voltage regulator (AVR)	M6	6
37	4	Tie rod	M8	20	322	1	Coupling discs	-	-
40	1	Plastic cover	-	-	323	6	Fixing bolts	M10	66
41	2	Terminal box front panel	-	-	324	1	Clamping washer	-	-
49	4	Terminal box bolts	M5	3.6	343	2	Diode bridge assembly	M5	4
53	1	Plug	-	-					

# TAL A40

## Low Voltage Alternators - 4 pole

### Disposal and recycling instructions

We are committed to limit the environmental impact of our activity. We continuously survey our production processes, material sourcing and products design to improve recyclability and diminish our footprint.

These instructions are for information purposes only. It is the user responsibility to comply with local legislation regarding product disposal and recycling.

The oil and grease from the lubrication system should be considered as a hazardous waste and has to be handled according to local legislation.

### Recyclable materials

Our alternators are mainly built out of iron, steel and copper materials, which can be reclaimed for recycling purposes.

These materials can be reclaimed through a combination of manual dismantling, mechanical separation and melting processes. Our technical support department can provide detailed directions on products dismounting upon request.

### Waste & hazardous materials

The following components and materials need a special treatment and need to be separated from the alternator before the recycling process:

- electronic materials found in the terminal box, including the Automatic Voltage Regulator (198), Current Transformers (176), interference suppression module (199) and other semi-conductors.
- diode Bridge (343) and Surge suppressor (347), found on the alternator rotor.
- major plastic components, such as the terminal box structure on some products. These components are usually marked with plastic type information.

All materials listed above need special treatment to separate waste from reclaimable material and should be handed to specialized disposal companies.

**LEROY-SOMER™**

[www.leroy-somer.com/epg](http://www.leroy-somer.com/epg)

[Linkedin.com/company/leroy-somer](https://www.linkedin.com/company/leroy-somer)

[Twitter.com/EPG\\_Alternators](https://twitter.com/EPG_Alternators)

[Facebook.com/LeroySomer.EPG](https://www.facebook.com/LeroySomer.EPG)

[YouTube.com/LeroySomerOfficiel](https://www.youtube.com/LeroySomerOfficiel)



***Nidec***  
All for dreams