

Nidec

Power

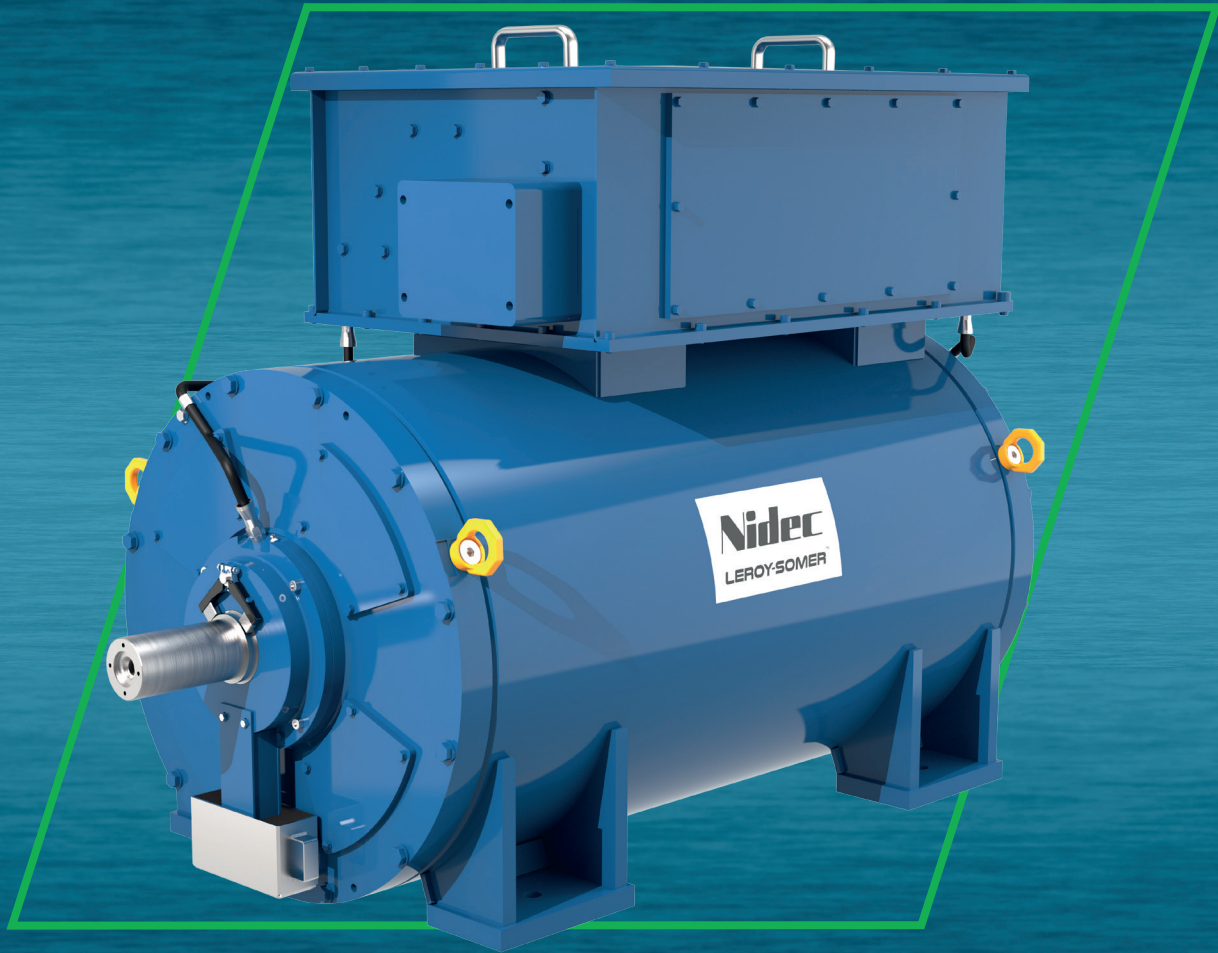

LSPM

**Low Voltage Permanent Magnet
Water Jacket Cooled Alternator - 8 poles**

2 500 Nm to 8 250 Nm
Electrical and mechanical data

LEROY-SOMER™

LSPM Water Jacket Cooled

The best of performance

The Leroy-Somer™ LSPM electrical machine has been designed to offer you the best power generation performances. With its meticulous design and optimized architecture, the LSPM strikes the perfect balance between compactness, reliability, performance and longevity. Whatever your application, the Leroy-Somer™ LSPM electrical machine will meet your needs and will adapt to all situations.

Standards

The Leroy-Somer™ LSPM electrical machine meets all key international standards and regulations such as IEC 60034, NEMA MG 1.32-33 and ISO 8528-3.

EC, UKCA and CMIM declarations and certifications are available for the LSPM.

The standards IEC 61000-6-2, IEC 61000-6-3, IEC 61000-6-4, VDE 0875G, VDE 0875N and EN 55011 allow compliance with group 1 class A for the European zone.

The Leroy-Somer™ LSPM electrical machine is designed, manufactured and marketed in an ISO 9001 and ISO 14001 quality assurance environment.

LSPM can be provided with a marine certificate. Nidec Power can work with most marine certification bodies.

Electrical characteristics and performances

- Class H insulation
- Design for variable speed application
- Stator design to be connected to power electric converter
- Insulation system compliant up to IVC Class C (IEC 60034-18-41)
- High efficiency
- Maximum speed: see opposite table
- 3 phase system
- Voltage range: up to 690V star connection
- Other voltages are possible, please contact us

Cooling system

- Nominal altitude (IEC 60034): <1 000m
- Cooling IC71W: water jacket cooled machine
- Cooling Liquid: clean fresh water with appropriate corrosive inhibitor and antifreeze additive (Ethylene glycol (Glysantin G48 recommended))
- Minimum cooling liquid temperature: -10°C
- Maximum cooling liquid temperature: 65°C
- Minimum ambient temperature: -10°C
- Maximum ambient temperature: 50°C
- Maximum operating pressure: 4 bar

Protection system

- Degree of protection: IP 54
- Complete winding protection for clean environments with relative humidity ≤ 95 %, including indoor marine environments
- Rotor grounding system
- Painting:
 - According to EN ISO 12944: C3 – System
 - RAL 7032 – NIDEC STANDARD

Mechanical construction

- Compact and rigid assembly to withstand system vibrations
- Steel frame
- Cast iron flanges and shields
- Antifriction bearing on DE and NDE
- Lubrication interval > 1 000h
- Insulated DE and NDE bearings
- Shaft end: cylindrical shaft
 - Optional cylindrical shaft end with key according to DIN 748-3 (key is included)
- SAE flange DE: to be agreed
- Shaft grounding system
- Half-key balancing (G2.5)
- Regreaseable bearings
- Rotation direction: bidirectional
- Inclination level - Roll (Static / Dynamic): 15° / 22.5°
- Inclination level - Pitch (Static / Dynamic): 5° / 7.5°

Terminal box design

- Easy access to the terminals
- Connection bars for voltage reconnection

Options

- Space heater: 250W, 240VAC
- Stator: 6 x PT100
- Bearing: 1 x PT100 per bearing
- Water temperature inlet / outlet PT100
- On demand:
 - Parking brake
 - Water leakage detector
 - Speed encoder or resolver

LSPM Water Jacket Cooled - 2 500 Nm to 8 250 Nm

General characteristics

Excitation system	Permanent magnet	Cooling water temperature	40°C
Pole number	8	Protection	IP 54
Winding pitch	5/6	Mounting	IM 1101
Number of terminals	3 x Phase + 1 Neutral	Cooling index	IC71W
Insulation class	H	Altitude	≤ 1000 m
Temperature rise class	F (105°C)		

Ratings

Type	Torque	Rated speed	Rated mechanical power	Rated electrical power	Maximum speed	Rated voltage	Rated current
	Nm	rpm	kWm	kWe	rpm	V	A
LSPM 48 WJ S8 8p	2 823	2 250	665	650	3 000	567	735
LSPM 48 WJ M10 8p	3 385	2 250	797	780	3 000	672	745
LSPM 48 WJ L10 8p	3 602	2 250	849	830	3 000	570	934
LSPM 49 WJ VS8 8p	4 582	2 000	960	940	2 500	669	902
LSPM 49 WJ S9 8p	4 875	2 000	1 021	1 000	2 500	568	1 130
LSPM 49 WJ L11 8p	5 845	2 000	1 224	1 200	2 500	675	1 141
LSPM 50 WJ S8 8p	6 800	2 000	1 424	1 400	2 500	674	1 332
LSPM 50 WJ M10 8p	7 288	2 000	1 526	1 500	2 500	557	1 727
LSPM 50 WJ VL11 8p	8 255	2 000	1 729	1 700	2 500	638	1 711

Type	Torque	Rated speed	Rated frequency	Rated efficiency	Water flow	Pressure drop
	Nm	rpm	Hz	%	l/mn	Bar
LSPM 48 WJ S8 8p	2 823	2 250	150	97.7	46	0.11
LSPM 48 WJ M10 8p	3 385	2 250	150	97.8	53	0.17
LSPM 48 WJ L10 8p	3 602	2 250	150	97.8	56	0.20
LSPM 49 WJ VS8 8p	4 582	2 000	133.3	97.9	59	0.13
LSPM 49 WJ S9 8p	4 875	2 000	133.3	97.9	63	0.19
LSPM 49 WJ L11 8p	5 845	2 000	133.3	98.0	73	0.25
LSPM 50 WJ S8 8p	6 800	2 000	133.3	98.3	74	0.18
LSPM 50 WJ M10 8p	7 288	2 000	133.3	98.3	81	0.25
LSPM 50 WJ VL11 8p	8 255	2 000	133.3	98.3	88	0.30

LSPM Water Jacket Cooled - 2 500 Nm to 8 250 Nm

LSPM 48 dimensions

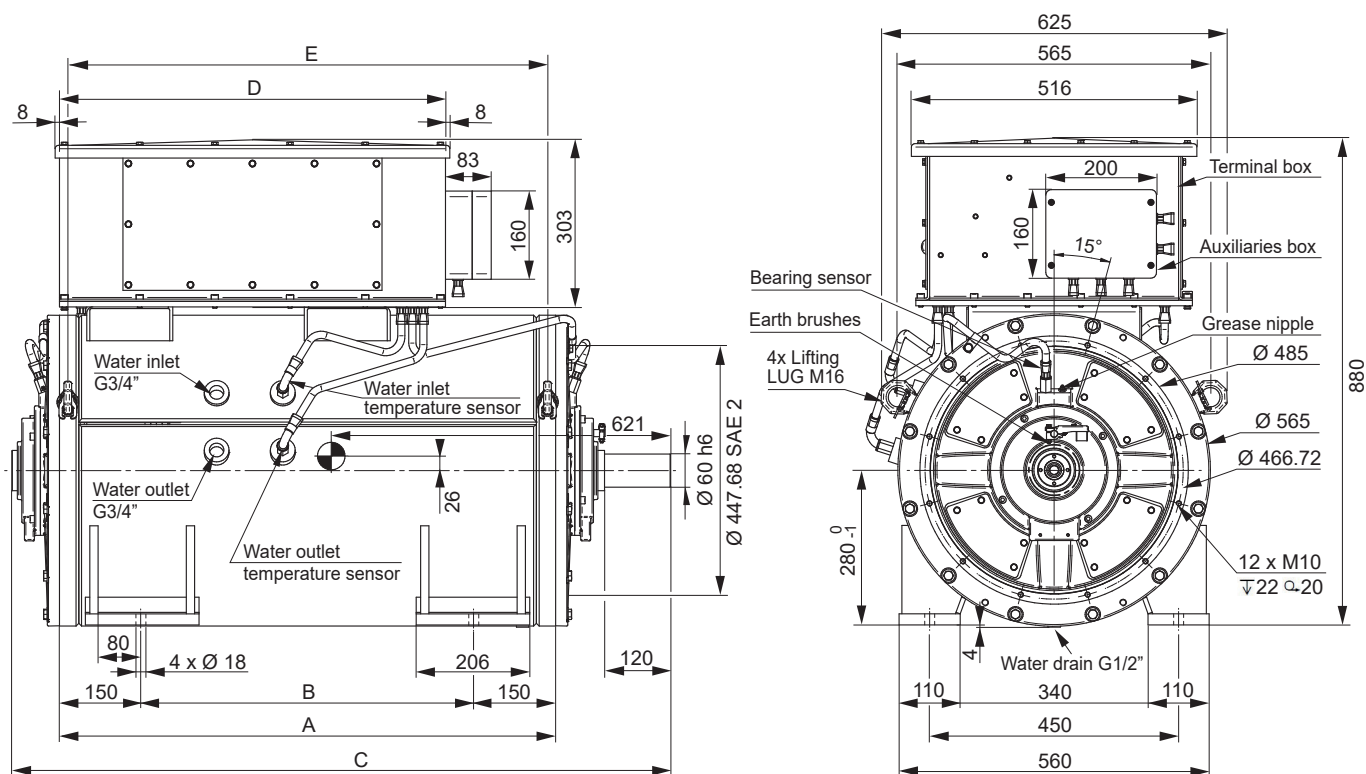

Type	Iron length (mm)	A (mm)	B (mm)	C (mm)	D (mm)	E (mm)	Machine weight (kg)	Rotor inertia (kg.m ²)
LSPM 48 WJ S8 8p	430	850	550	1 145	666	820	1 038	3.9
LSPM 48 WJ M10 8p	500	900	600	1 195	700	870	1 130	4.5
LSPM 48 WJ L10 8p	540	950	650	1 245	733	920	1 189	4.9

LSPM 48 torsional analysis data

Type	K1 Inertia (kg.m ²)	J1 Torsional stiffness (N.m/rd)
LSPM 48 WJ S8 8p	4.0	9.40E+05
LSPM 48 WJ M10 8p	4.6	9.34E+05
LSPM 48 WJ L10 8p	5.0	9.30E+05

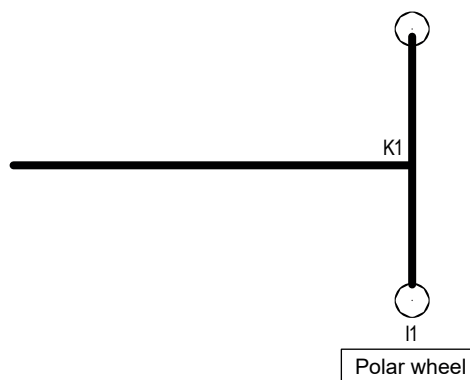

NOTE : Dimensions are for information only and may be subject to modifications. Contractual 3D drawing files are available upon request. The torsional analysis of the transmission is imperative. All values are available upon request.

LSPM Water Jacket Cooled - 2 500 Nm to 8 250 Nm

LSPM 49 dimensions

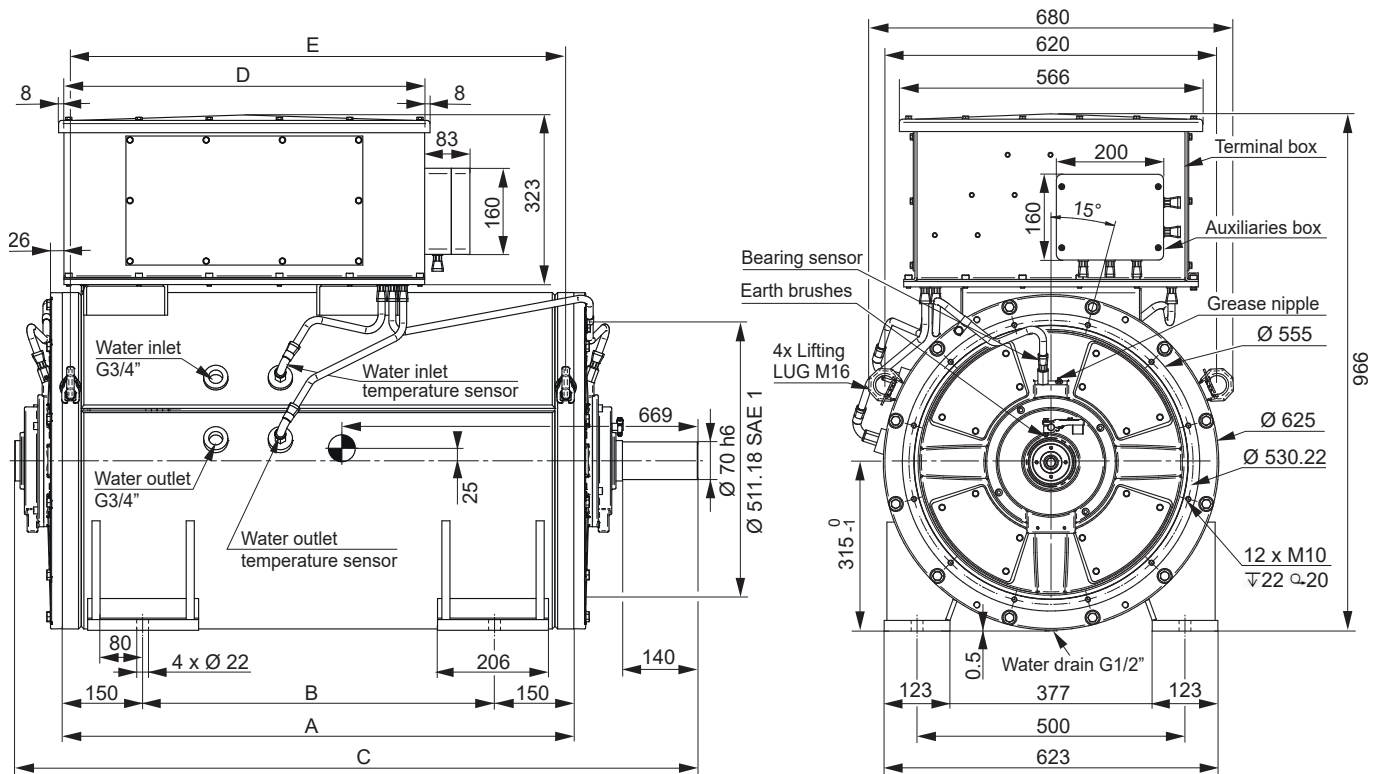

Type	Iron length (mm)	A (mm)	B (mm)	C (mm)	D (mm)	E (mm)	Machine weight (kg)	Rotor inertia (kg.m ²)
LSPM 49 WJ VS8 8p	500	900	600	1 219	700	870	1 342	8.1
LSPM 49 WJ S9 8p	540	950	650	1 269	733	920	1 414	8.8
LSPM 49 WJ L11 8p	630	1 050	750	1 369	800	1 020	1 573	10.12

LSPM 49 torsional analysis data

Type	K1 Inertia (kg.m ²)	J1 Torsional stiffness (N.m/rd)
LSPM 49 WJ VS8 8p	8.3	1.37E+06
LSPM 49 WJ S9 8p	9.0	1.37E+06
LSPM 49 WJ L11 8p	10.3	1.35E+06

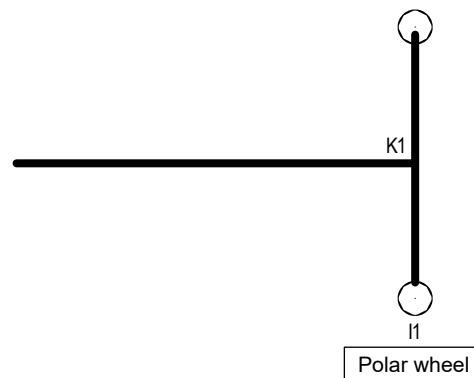

NOTE : Dimensions are for information only and may be subject to modifications. Contractual 3D drawing files are available upon request. The torsional analysis of the transmission is imperative. All values are available upon request.

LSPM Water Jacket Cooled - 2 500 Nm to 8 250 Nm

LSPM 50 dimensions

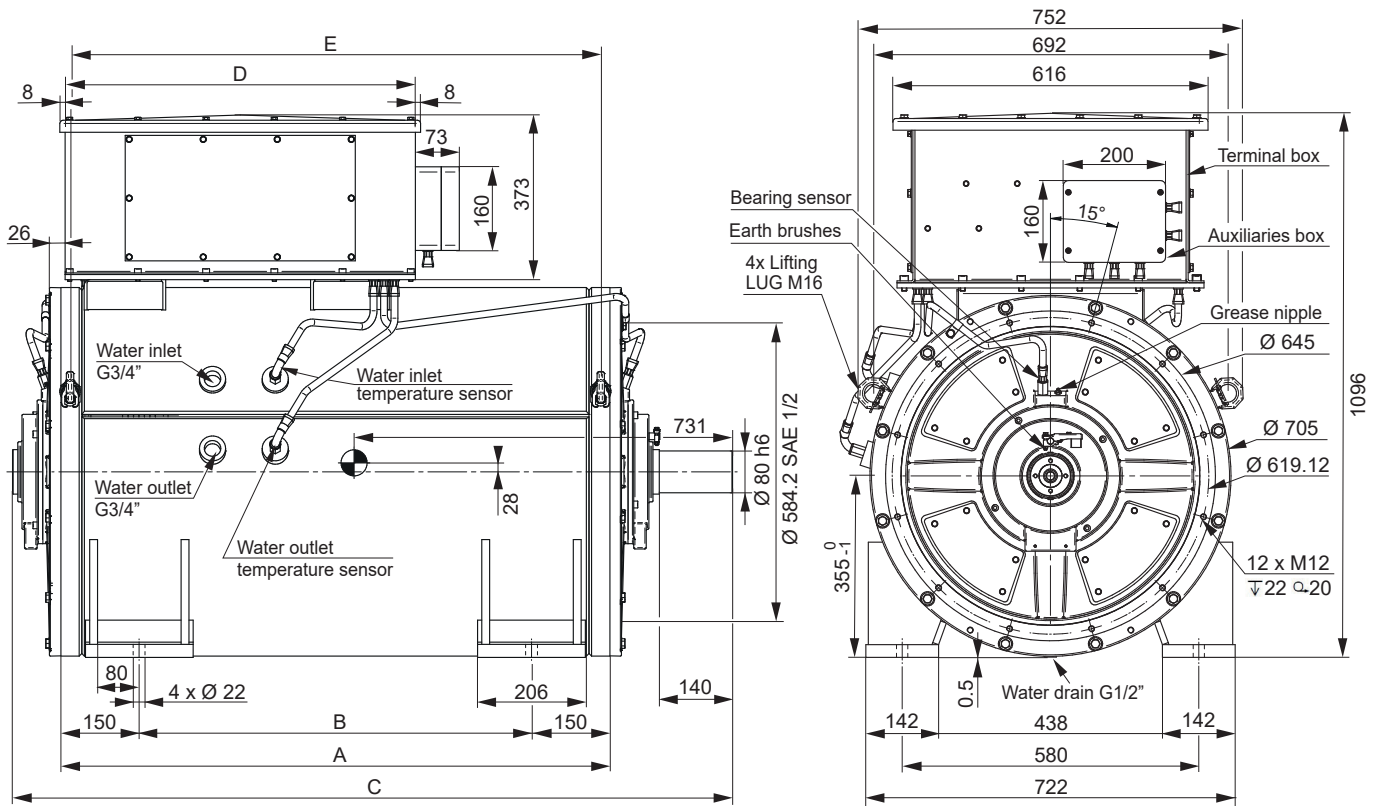

Type	Iron length (mm)	A (mm)	B (mm)	C (mm)	D (mm)	E (mm)	Machine weight (kg)	Rotor inertia (kg.m ²)
LSPM 50 WJ S8 8p	560	1 000	700	1 327	766	965	1 790	12.2
LSPM 50 WJ M10 8p	630	1 050	750	1 377	800	1 015	1 930	13.6
LSPM 50 WJ VL11 8p	710	1 150	850	1 477	866	1 115	2 108	15.3

LSPM 50 torsional analysis data

Type	K1 Inertia (kg.m ²)	J1 Torsional stiffness (N.m/rd)
LSPM 50 WJ S8 8p	12.1	2.05E+06
LSPM 50 WJ M10 8p	13.8	2.01E+06
LSPM 50 WJ VL11 8p	15.6	2.02E+06

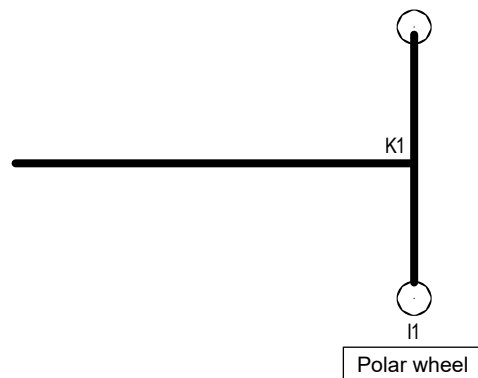

NOTE : Dimensions are for information only and may be subject to modifications. Contractual 3D drawing files are available upon request. The torsional analysis of the transmission is imperative. All values are available upon request.



www.nidecpower.com

Connect with us at:



© 2026 Moteurs Leroy-Somer SAS. The information contained in this brochure is for guidance only and does not form part of any contract. The accuracy cannot be guaranteed as Moteurs Leroy-Somer SAS have an ongoing process of development and reserve the right to change the specification of their products without notice.

Moteurs Leroy-Somer SAS. Headquarters: Bd Marcellin Leroy, CS 10015, 16915 Angoulême Cedex 9, France. Share Capital: 32,239,235 €, RCS Angoulême 338 567 258.