

# Instruction Manual

---

Installation  
Operation  
Maintenance

AC Generator  
Center Air Discharge

Publication  
350-01015-00 (11/24/2015)

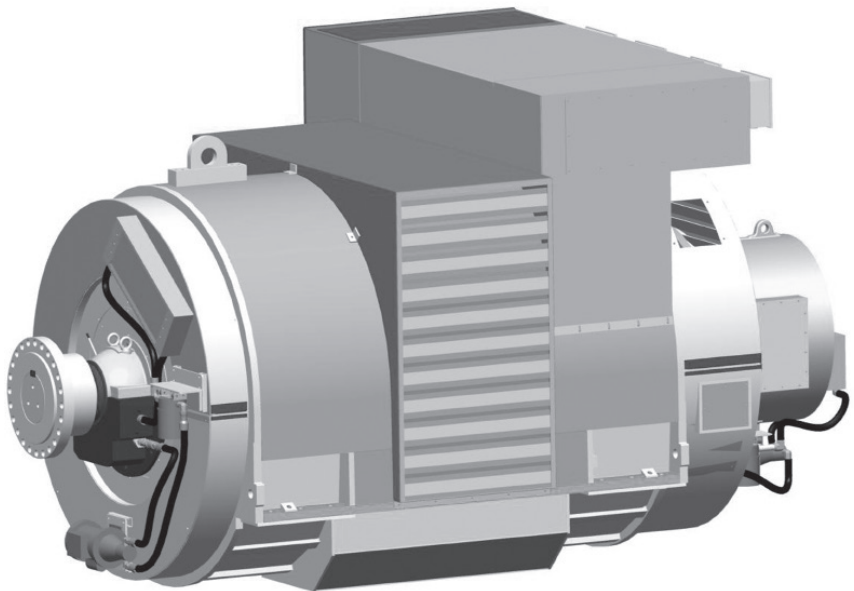

***Nidec***  
**KATO ENGINEERING™**

---

Kato Engineering, Inc. | P.O. Box 8447 | Mankato, MN USA 56002-8447 | Tel: 507-625-4011  
KatoEngineering@mail.nidec.com | www.KatoEngineering.com | Fax: 507-345-2798

Copyright © 2012 Kato Engineering, Inc. All rights reserved

# Table of Contents

<b>Introduction</b>	<b>4</b>
Foreword	4
Safety instructions	4
Ratings/description	4
<b>Construction and Operating Principles</b>	<b>6</b>
Stator	6
Rotor	7
Bearings	8
Connection boxes	8
Excitation system	9
PMG system	11
<b>Installation</b>	<b>12</b>
Receiving inspection	12
Unpacking and moving	12
Location	12
Base design	12
Assemble to prime mover, alignment	13
Two-bearing alignment	13
Foot deflection	15
Doweling	15
Electrical connections	15
Space heaters	15
Inspection before startup	15

**Note:** *Because of rapid changes in designs and processes and the variability of Kato Engineering's products, information in this manual must not be regarded as binding and is subject to change without notice.*

*The image on the front cover is representative only. Several variations are available within the range of generators covered within this manual.*

<b>Storage of Kato Generators</b>	<b>17</b>
<b>Operation</b>	<b>20</b>
Initial startup: generators w/auto & manual control	20
Initial startup: generators w/auto control only	20
Restoring residual magnetism/field flashing	21
Continuous operation	22
Idling	23
Parallel operation	23
<b>Maintenance</b>	<b>26</b>
Schedules	26
Maintenance procedures	28
Visual inspection methods of windings	28
Cleaning	29
Insulation resistance tests at low voltage	30
Dry out procedures	31
Bearing lubrication	32
Rectifier tests	32
Disassembly	34
Overall disassembly	34
Exciter armature and PMG removal	34
Bearing removal	35
Assembly	37
Bearing installation	38
Exciter armature and PMG installation	40
<b>Troubleshooting Guide</b>	<b>42</b>
<b>Torque Chart</b>	<b>45</b>
<b>List of Required Equipment</b>	<b>47</b>

# Introduction

## Foreword

This manual contains instructions for installing, operating and maintaining Kato Engineering AC brushless revolving field generators. These generators are manufactured in many sizes and ratings and with various options.

Lubrication information, electrical connection drawings, dimensional drawings and parts listings for your model are contained in the manual package as supplementary information and are the specific source of information for making connections and ordering replacement parts. Information about optional components of your generator may also be contained as a supplement.

Please read this manual in its entirety before unpacking, installing, and operating your generator.

## Safety instructions

In order to prevent injury or equipment damage, everyone involved in installation, operating and maintenance of the generator described in this manual must be qualified and trained in the current safety standards that govern his or her work.

While “common-sense” prevention of injury or equipment damage cannot be completely defined by any manual (nor built into any piece of equipment), the following paragraphs define warnings, cautions, and notes as they are used in this manual:

**Warning:** Warnings identify an installation, operating or maintenance procedure, practice, condition, or statement that, if not strictly followed, could result in death or serious injury to personnel.

**Caution:** Cautions identify an installation, operating or maintenance procedure, practice, condition, or statement that, if not strictly followed, could result in destruction of or damage to equipment or serious impairment of system operation.

**Note:** Notes highlight an installation, operating or maintenance procedure, condition, or statement and are essential or helpful but are not of known hazardous nature as indicated by warnings and cautions.

## Ratings/description

Nameplates, which are located on the side of the generator, include serial and model number as well as rating information and bearing and lubrication information.

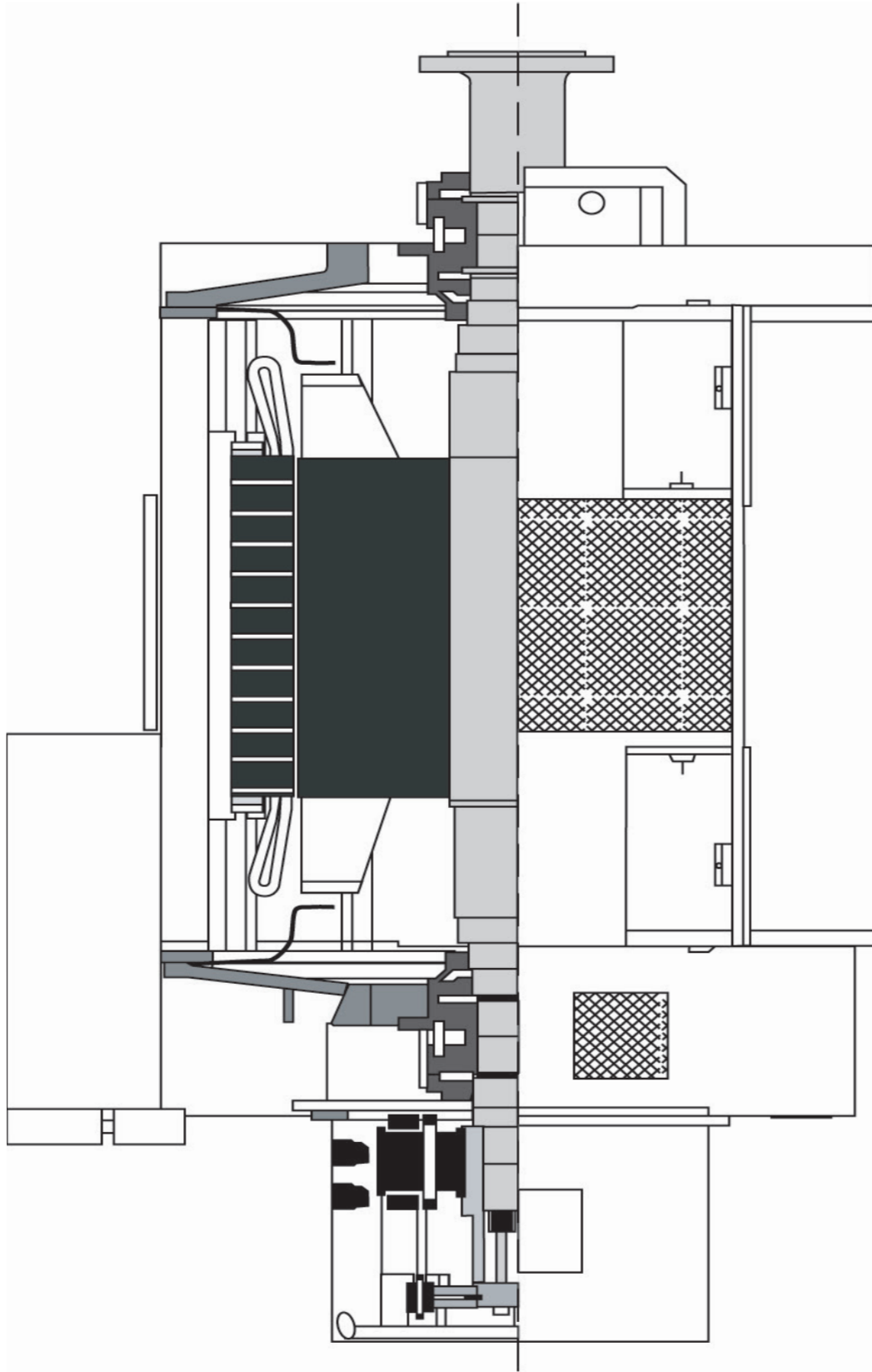

Figure 1: Typical center air generator

# Construction and Operating Principles

## Enclosures

The standard design is open drip proof. The following options may apply to your unit:

- Air filtered
- Air-to-air heat exchanger cooled (TEAC/CACA)
- Air-to-water heat exchanger cooled (TEWAC/CACA)
- Weather protected II
- IP 22, 23,25,44,54
- Sealed windings

See your drawings included in the drawing section for details on your unit.

## Stator

The stator consists of the supporting frame, core, and armature windings.

The stator core is made from laminations, thin sheets of electrical steel, which are stacked and held in place by steel end rings and support bars. The rings and bars are welded to or are part of the steel frame. Base mounting plates are welded to the bottom of the frame. The base mounting plates allow the assembly to be mounted on the genset base. Some stators are made of rolled steel with foot gussets. See Figure 2.

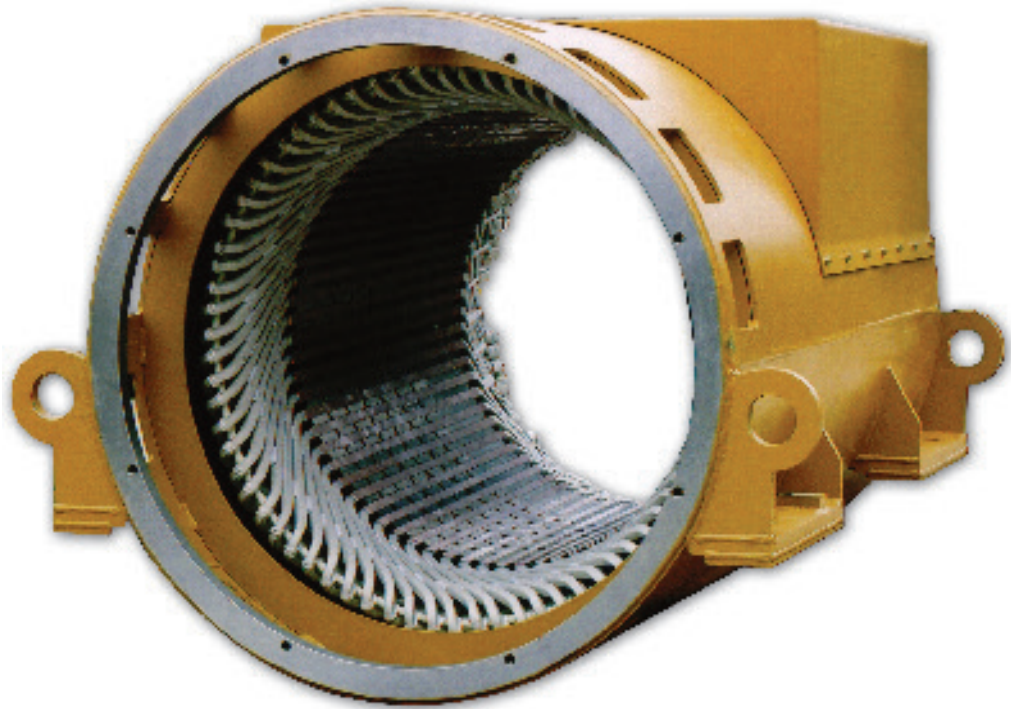

Figure 2: Generator frame

The windings (coils) are constructed of layered and insulated copper wire. The coils are inserted in the core slots, connected together, and the entire assembly is vacuum-pressure impregnated with resin. Stator leads terminate in standard connection lug or strap terminals for ease of connection to the load.

## **Rotor**

The main rotor assembly is the revolving field. It consists of windings in a core, which is in turn mounted on a steel shaft. The exciter armature assembly and permanent magnet generator (PMG) rotor are also mounted on the shaft as are the fan(s) and other optional accessories. The core consists of laminations, thin sheets of electrical steel, which are stacked together. The core makes the salient poles. See Figure 3.

The rotor windings consist of insulated magnet wire wound around each pole. V-blocks or spreader bars between each pole keep the rotor windings in place. Damper windings consist of copper or aluminum rods that are inserted through each pole surface and are brazed to copper or aluminum damper end plates at each end of the lamination stack.

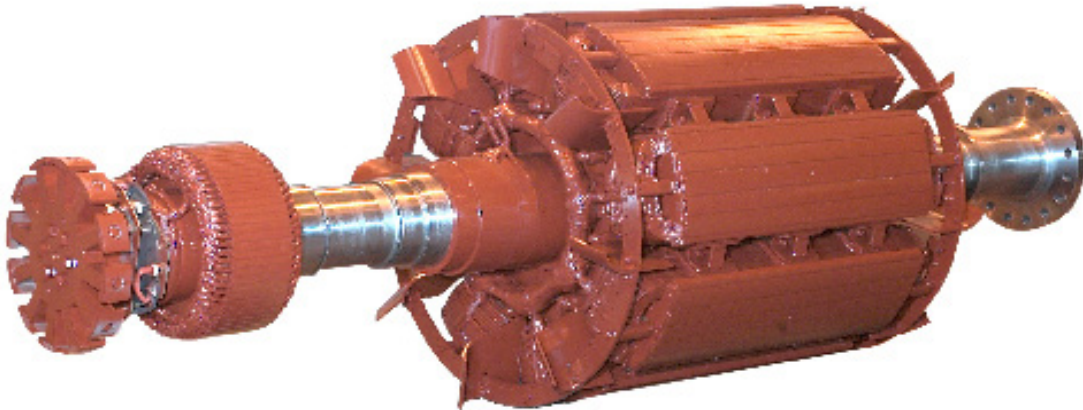

Figure 3: Generator rotor

The end plates are brazed to adjacent poles to form a continuous damper winding. The ends of the windings are supported with bars or aluminum pole shoes. Some designs have neither end shoes or plates. The rotor is vacuum-pressure impregnated with resin.

The shaft is made from high-strength rolled or forged steel and machined to accommodate all the rotating generator components. Keyways in the shaft ensure precise positioning of the rotor, fans, exciter armature, and PMG rotor as well as drive couplings. On the exciter side, the shaft has a slot or hole in its centerline for running the revolving field leads to the rectifier.

## Bearings

The sleeve bearings may be self lubricated or force fed from a separate oil system. Temperature detectors monitor the operating conditions of the bearing and lubrication system. The sleeve bearing is self-aligning. See bearing manual for details. RTDs are provided to monitor bearing temperature during operation. A non-conducting liner insulates the bearing against shaft currents. See your bearing manual under separate cover for more information. See Figure 4.

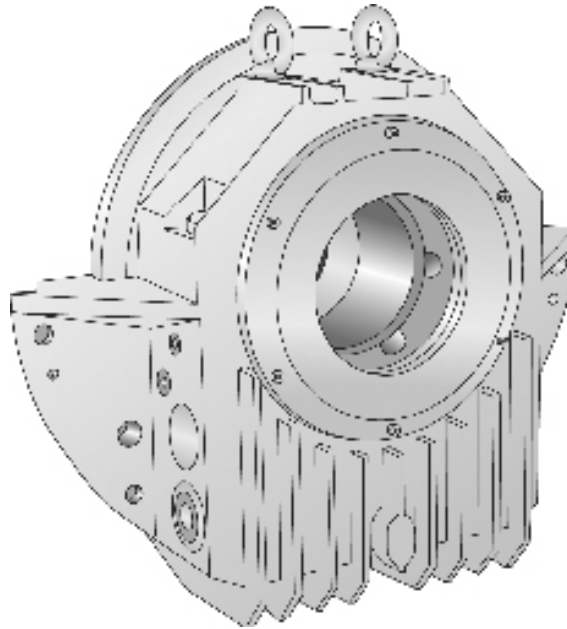

Figure 4: Sleeve bearing

## Connection boxes

The main lead connection box houses the load lead terminals, and may be located either side or on top. In addition, the generator may have auxiliary connection boxes for connecting temperature detector outputs, space heater connectors, and sensing outputs. See your drawings for details. See Figure 5.

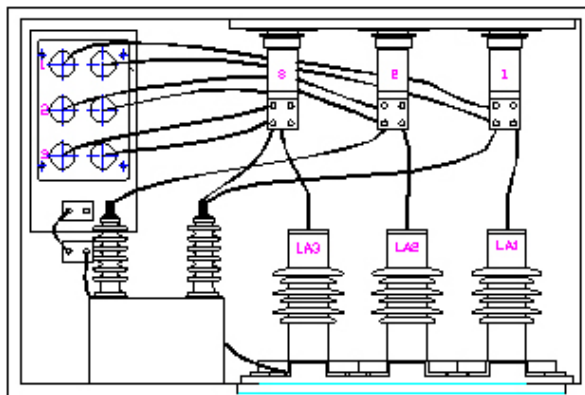

Figure 5: Typical terminal box

## Excitation system

The excitation system consists of the exciter stator assembly and the exciter armature assembly. See Figure 6.

The exciter stator assembly consists of windings in a core. The core is made from steel laminations that are stacked and welded together. The main exciter stator coils are placed in slots in the core and form alternate north and south poles. The entire assembly is either mounted to the end bracket or mounted in a frame, which is mounted to the end bracket. The stator is a stationary field, which is powered by the voltage regulator.

The assembly consists of two subassemblies: the exciter armature and the rotating rectifier. The exciter armature assembly contains steel laminations that are stacked and keyed on the shaft or onto a sleeve, which is keyed to the generator shaft. A three-phase winding is inserted into slots in the laminations. The coils are held in place by insulating wedges. The coil extensions are braced with tape. Output leads from the winding are connected to the rotating rectifier assembly.

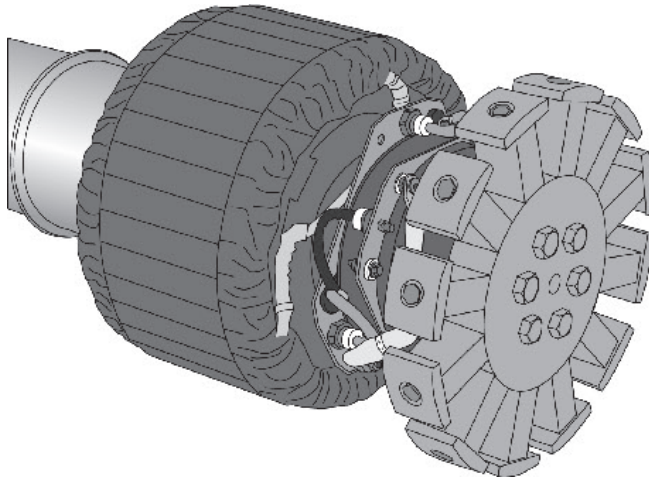

Figure 6: Excitation system

The rotating rectifier is a three-phase, full wave bridge rectifier, converting the AC from the exciter armature to DC, which is transferred to the revolving field windings. Two aluminum steel plates, each containing three rotating rectifier diodes, are mounted on each side of an insulating hub to form the negative and positive terminals. The plates also act as heat sinks for the diodes.

Excitation system functional overview: Exciter field control is established by the strength of the exciter field current developed by the voltage regulator system. The DC voltage and current levels of the exciter field signal from the voltage regulator varies depending upon the generator output voltage and the loading of the output lines. See Figure 7.

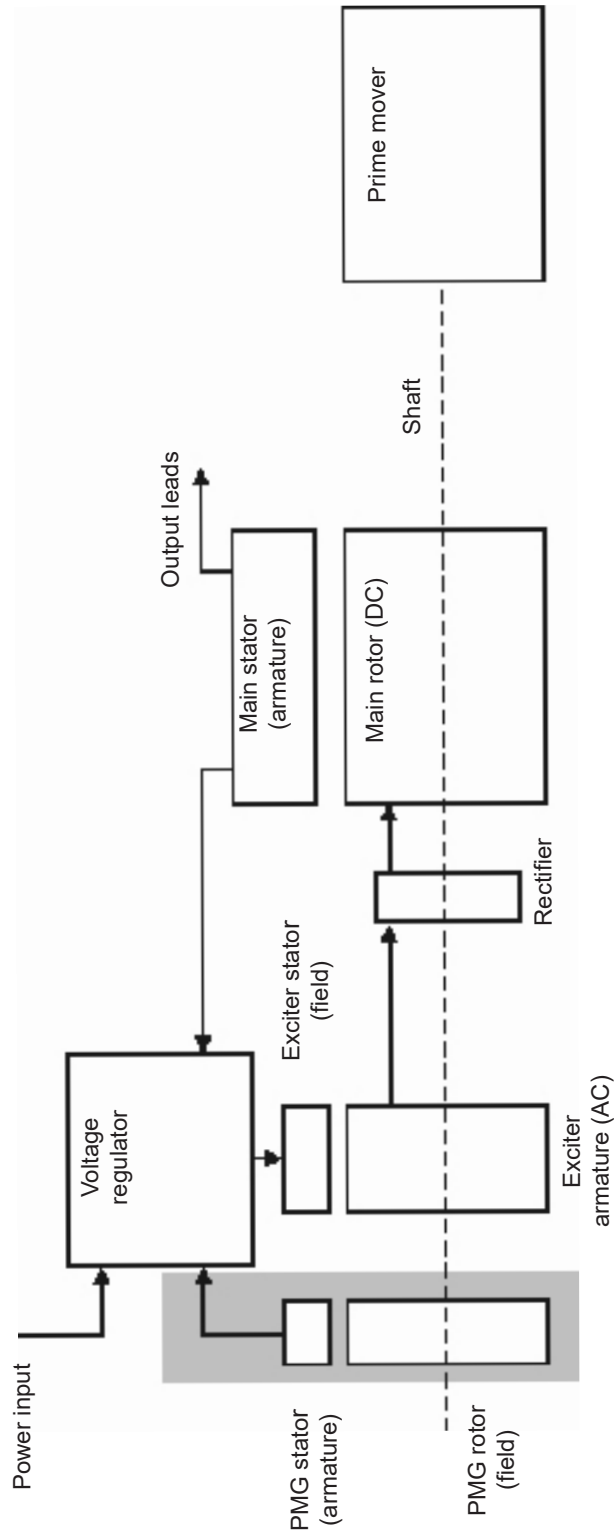

Figure 7: Overview of excitation system

## PMG system

The permanent magnet generator (PMG) system consists of the PMG stator and PMG rotor:

The PMG stator is a stationary armature and is located within the stator assembly that also contains the exciter stator or is a separate stator mounted next to the exciter stator. The PMG stator consists of steel laminations. The laminations are held in place by steel compression rings and are welded to the frame bars of the exciter-PMG frame. The PMG windings are placed in slots in the laminations. Insulating wedges are inserted at the top of each slot to hold the coils in position.

The PMG rotor consists of rectangular permanent magnets and cast pole tips secured to a steel hub with nonmagnetic stainless steel bolts. The PMG rotor is keyed to the shaft and secured with a nut and lock washer.

PMG system overview: The PMG system functions as a pilot exciter, providing power to the automatic voltage regulator power supply. The PMG is an AC generator that uses permanent magnets in the rotor instead of electromagnets to provide the magnetic field. See Figure 8.

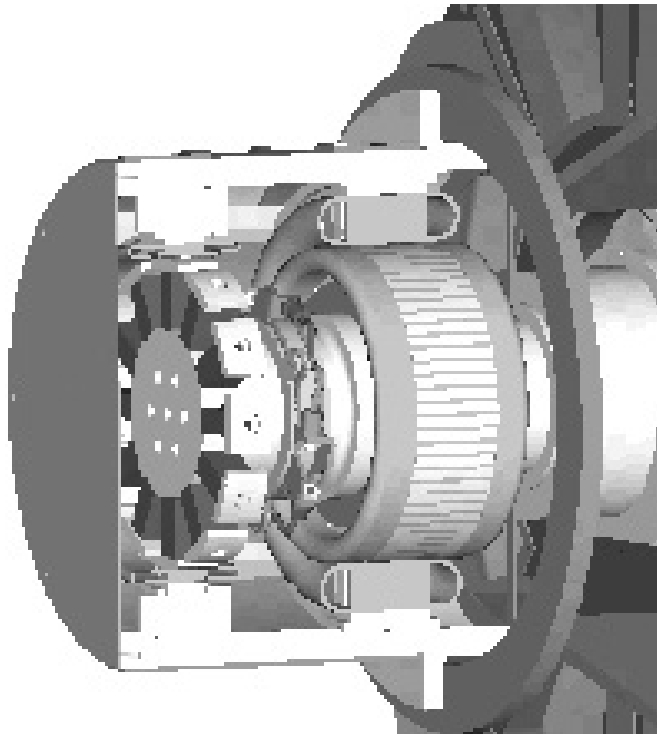

Figure 8: PMG

**Warning:** *Be alert at all times when installing, operating and maintaining the generator. Avoid contact with the uninsulated metal parts of the generator. Most injuries occur from faulty ground connections on portable electrical equipment and failure to ground stationary equipment.*

*Test all portable devices frequently to prove that a solid electrical circuit exists from the metal frame through the grounding conductor, in the electrical cord, to the grounding contact in the attachment plug. Do not use electrical equipment with frayed, burned or damaged cords. Always take extreme care when moving the generator. Be careful to not strike objects or personnel.*

*Apply lifting force to structural points specifically provided for lifting. Do not use the enclosure lifting holes to lift the whole unit. Use lifting means adequate for the weight. Observe lifting notices attached to the generator. Failure to observe these instructions can result in injury and damage to the generator.*

**Caution:** *Do not attempt to transport a single-bearing generator without maintaining proper rotor support and with the exciter rotor assembly removed. Failure to observe this warning can result in equipment damage.*

**Caution:** *Blocking or restriction of normal air flow into or out of the generator may cause damage to the electrical windings.*

## Installation

### Receiving inspection

Before accepting a shipment, examine the packaging for any sign of damage that might have occurred during transit. Report any damage to the transportation company and Kato Engineering.

### Unpacking and moving

If the generator is received during cold weather, reduce condensation on cold surfaces and failure due to wet windings by allowing the generator to reach room temperature before removing the protective packing.

Unpack the generator carefully to avoid scratching painted surfaces. Do not remove the protecting lubricant from the shaft end. Inspect for loosely mounted components and the presence of moisture. Inspect to make certain foreign material, such as crating nails, loose bolts or packing material, which may have fallen into the machine during unpacking, is removed. If damage is noted, determine the extent of damage and immediately notify the transportation company claims office and Kato Engineering. Be sure to give complete and accurate details when reporting damage.

Move the generator by attaching an overhead hoist to the eyebolts installed on the generator frame or by lifting the generator from underneath the skid with a forklift.

### Location

Install the generator in an area so it complies with all local and industrial regulations. Locate it in a clean, dry, well-vented area or area that is suitable for the generator enclosure. Make sure it is easily accessible for inspection and maintenance.

Protect generators operating intermittently in very damp locations with space heaters. Slowly warm generators placed in operation after being subjected to very low temperatures to prevent excessive condensation. Check winding resistance before placing the generator in operation (see page 27).

### Base design

The type of base to be used will depend upon the nature of the installation site. However, the generator base must be rigid, level, and free from vibration. Mounting holes must be larger than the fasteners to allow for alignment.

## Assemble to prime mover, alignment

### Two-bearing alignment

Follow the tolerances specified by the coupling manufacturer when they are less than described in this manual.

Use shims, if necessary, between the mounting pad and the base to properly level and align the generator to the prime mover.

Install the coupling(s) on the generator and engine drive shafts in accordance with coupling manufacturer installation procedures. Use a straight edge and a thickness gauge for rough alignment as shown in Figure 9. Check for angular and parallel alignment as follows:

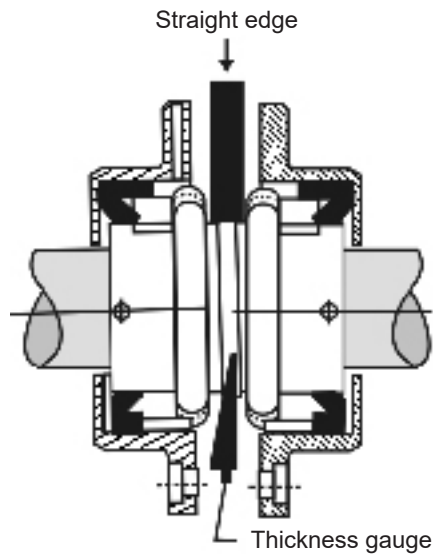

Figure 9: Rough alignment

**Angular alignment:** Fasten a dial indicator to one of the coupling halves, and scribe the position of the dial button on the face of the opposite coupling half as shown in Figure 10. Rotate both shafts simultaneously, keeping the finger or button on the indicator at the reference mark on the coupling hub. Note the reading on the indicator dial at each one quarter revolution.

A variation of readings at different positions will indicate how the machine needs to be adjusted to obtain a maximum misalignment of 0.001 inch for each inch of the coupling hub's radius, total indicator runout. Place or remove slotted shims from under the front or rear engine or generator mounting pads and/or shift the front or back half of one component from side to side until the components are properly aligned. Tighten the mounting bolts, and recheck alignment.

**Notes:** Mounting of the indicators must allow complete rotation of the prime mover.

Use dial indicators that are rigid so indicator sag won't be a factor. Using the shortest offset distance of the indicator bracket will reduce the effects of indicator droop or sag.

During alignment, you may also need to compensate for engine expansion due to heating. Generator expansion is generally not considered a factor.

If the genset is moved to a different location, check alignment before startup.

**Caution:** Do not pry on the generator fan.

**Caution:** Generators equipped with sleeve oil bearings must have oil added to the bearing prior to rotation. See the bearing manual.

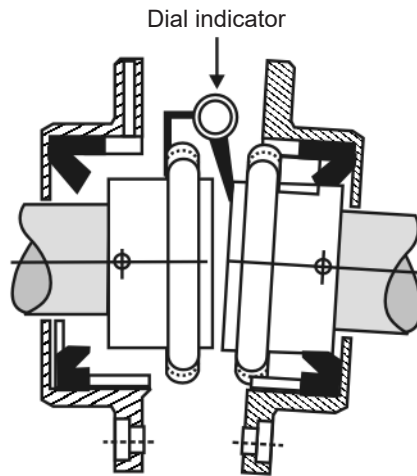

Figure 10: Angular alignment

Parallel alignment: Fasten a dial indicator to one of the coupling halves, and scribe the position of the dial button on the top of the opposite coupling half as shown in Figure 11. Rotate both shafts simultaneously, keeping the finger or button on the indicator at the reference mark on the coupling hub. Note the reading on the indicator dial at each one quarter revolution. A variation of readings at different positions will indicate how the machine needs to be adjusted to obtain a maximum misalignment of 0.002 inch. Place or remove slotted shims from under all of the engine or generator mounting pads and/or shift one component from side to side until the components are properly aligned. Tighten the mounting bolts, and recheck alignment.

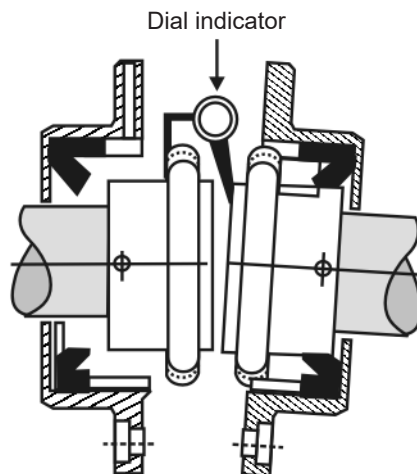

Figure 11: Parallel alignment

## Foot deflection

After alignment, check for foot deflection or “soft foot” condition on each shim location to eliminate distortion of the generator frame. Do this by loosening one mounting bolt at a time and checking deflection after retightening. Deflection at the shim location from shims under compression to a loosened condition must not exceed 0.003 inch.

## Doweling

In case the mounting bolts loosen during operation, doweling will prevent movement of the generator. Dowel as follows:

Check the alignment after the generator has been in operation for at least 48 hours. If alignment is not satisfactory, realign.

Drill holes through the footpads and into the base in two mounting pads opposite each other. Drill the holes slightly smaller than the dowel pin.

Ream the holes to the proper diameter for the pin. Clean out chips, and install the pins.

## Electrical connections

If the generator was subjected to a rapid change in temperature, freezing or wet conditions during shipment or storage, measure the insulation resistance of each winding and dry the generator, if necessary, as described in the maintenance section.

Make all electrical connections (main load, temperature monitoring device, space heater, AVR) in accordance with local regulations and national/international electrical code requirements. Check the electrical diagrams provided with the generator or manual. The main terminals need to be properly spaced for the load connections. Refer to Table 3 for the proper torque values for the connections.

Grounding points are provided for properly grounding the system to the generator frame. The grounding wire must be sized to national/international code requirements.

## Space heaters

To prevent water condensation during long periods of downtime, connect the space heaters so they start when the generator is turned off and stop when the generator is switched on. Refer to the electrical diagrams for the space heater characteristics.

## Inspection before startup

After electrical connections have been made, perform the following checks:

**Notice:** *Alternator current machines are intended for continuous operation with the neutral at or near ground potential. Operation with one line at ground potential should be done only for infrequent periods of short duration, for example, as required for normal fault clearance.*

**Warning:** *The space heaters are designed to be energized when the generator is shut down. They are hot enough to cause skin burns. Terminals for power at the space heaters are live during operation. Disconnect power to the space heaters before removing the generator covers.*

- a. Check all the connections to the electrical diagrams provided.
- b. Secure all covers and guards.
- c. Turn the rotor slowly with the appropriate starting mechanism (bar the engine or flywheel) through one revolution to see if the rotor turns freely.
- d. Check the bearings to see they are properly lubricated.
- e. Determine the direction of the engine rotation, and make sure that it matches the rotation of the generator.
- f. Make sure the power requirements comply with the data on the generator nameplate.
- g. Make sure that the engine-generator set is protected with an adequate engine governor and against excessive overspeed.
- h. Make sure the output of the generator is protected with an overload protection device, such as circuit breakers or fuses, sized in accordance with national/international electrical code and local electrical code standards. Fuses need to be sized using the lowest possible current rating above the full-load current rating (115% of rated current is commonly recommended).
- i. Remove tools and other items from the vicinity of the generator.

# Storage of Kato Generators

If the generator is not installed in its operating location as soon as received, follow the following procedures.

Recommended storage area temperature is between 0° F (-18° C.), (lower if the machine is designed for lower temperatures, check your nameplate), and 120° F (49° C.) and the relative humidity is less than 60%.

Protect the shaft from corrosion by applying an anti-corrosion agent. Cover the unit with a durable cover.

Prepare units that cannot be stored in a temperature and humidity controlled area as follows:

- a. Install desiccant bags in the exciter cover and inside the end bells.
- b. Vacuum seal the unit in a covering of plastic or other material designed for that purpose.
- c. Adequately tag the generator to ensure that preservative greases and desiccant bags are removed before the unit is placed in operation.
- d. If space heaters are supplied, energize them to keep condensation from the windings.
- e. Lubricate the sleeve bearings and the shaft as describe in the following paragraphs.

**On applications where the generator has been coupled to the prime mover the prime mover and the generator may be rotated as a complete unit.**

For storage longer than 2 months, rotate the shaft a minimum of 10 revolutions every 60 days. If the generator has an automatic lubrication system activate it before turning the shaft. If the generator has an manual prelube pump; actuate before rotating the shaft. If the generator has no prelube system, remove the access glass or top vent and pour oil into bearing before rotating the shaft.

**On applications where the prime mover is coupled to the generator and the prime mover manufacturer requires that the prime mover NOT be rotated at periodic intervals.**

**WARNING:** *When removing the oil or external lubrication system from bearings for long term storage oil must be added to the bearing, or the external lubrication system must be reconnected prior to operation. Please refer to the generator lubrication plate and the generator dimensional drawing for amount of oil required or location for oil input and drain port locations.*

1. Separate the coupling from the prime mover and the generator and rotate the generator separately a minimum of 10 revolutions every 60 days. If the generator has an automatic lubrication system activate it before turning the shaft. If the generator has a manual prelube pump; actuate it before rotating the shaft. If the generator has no prelube system, remove the access glass or top vent and pour oil into bearing before rotating the shaft.
2. If it is not possible to rotate the generator separately then flush the bearings with an anti rust preservative using one of the two following procedures; the first for self contained ring oil lubrication and the second for bearings with an external lubrication system.

**Bearing preservation for generators equipped with sleeve bearings with a self contained ring oil lubrication.**

1. Remove oil drain port plug and drain oil from the bearing (refer to the specific generator outline drawing for drain location).
2. Identify the sleeve bearing casing oil inlet port on one side of the bearing (refer to the specific generator outline drawing oil inlet location).
3. Attach a manual pump filled with Daubert Nox-Rust VCI-10 preservative. Flush 2 gallons of the preservative through the oil inlet port for 1 minute at 2 GPM flow. Drain the bearing casing after flushing and reinstall the drain and oil plugs. Repeat this procedure for each bearing.
4. Repeat the flushing procedure every 12 months.

**Bearing preservation for generators equipped with sleeve bearings with an external lubrication system.**

1. Disconnect external lubrication system following the manufactures recommendations.
2. Identify the sleeve bearing casing oil inlet port on one side of the bearing and the drain port underneath the bearing casing (refer to the specific generator outline drawing for oil inlet and drain locations).

**Caution:** *Before using this product, the operator must read carefully the MSDS sheet to ensure that the process is carried out safely for the operator and the environment.*

**Note:** *It should not be necessary to open the bearing for cleaning the remaining preservative before starting the generator, however it is recommended to verify the compatibility of the VCI-10 oil with the specific oil used to lubricate the bearings.*

3. Attach a manual pump filled with Daubert Nox-Rust VCI-10 preservative. Flush 2 gallons of the preservative through the oil inlet port for 1 minute at 2 GPM flow. Drain the bearing casing after flushing and reinstall the drain and oil plugs. Repeat this procedure for each bearing.
4. Repeat flushing procedure every 12 months

When the unit is taken out of storage, check the insulation resistance on all windings. See pages 30 and 31.

Clean the shaft of anti-corrosion agent.

**Caution:** *Before using this product, the operator must read carefully the MSDS sheet to ensure that the process is carried out safely for the operator and the environment.*

**Note:** *It should not be necessary to open the bearing for cleaning the remaining preservative before starting the generator, however it is recommended to verify the compatibility of the VCI-10 oil with the specific oil used to lubricate the bearings.*

**WARNING:** *When removing the oil or external lubrication system from bearings for long term storage oil must be added to the bearing, or the external lubrication system must be reconnected prior to operation. Please refer to the generator lubrication plate and the generator dimensional drawing for amount of oil required or location for oil input and drain port locations.*

# Operation

**Caution:** Do not make connections or otherwise make contact with the generator leads or other devices connected to them unless the genset is stopped and the phase leads are grounded.

**Caution:** Do not actuate the auto-manual switch with full load applied to the generator. Whenever possible, stop the generator before switching.

**Caution:** Operating the unit beyond nameplate values may cause equipment damage or failure.

**Caution:** Refer to the voltage regulator manual for complete details and possible additional instructions. Damage to the rotating diodes, generator, and voltage regulator can be caused if the regulator is operated improperly.

## **Initial startup: generators with both automatic and manual voltage control**

1. Disconnect the generator output from the load by opening the main circuit breaker.
2. Turn the manual voltage adjust rheostat fully counterclockwise.
3. Put the auto-manual switch in the manual position.
4. Start the prime mover, and bring the set to rated speed. Turn the manual voltage adjust rheostat to reach rated voltage. Close the output circuit breaker, and apply load in steps until the rated load is reached. Adjust the manual adjust rheostat as necessary to obtain the desired output voltage.
5. Gradually reduce load, and adjust the rheostat accordingly until no load is reached. Open the circuit breaker, and stop the prime mover.
6. Actuate the auto voltage rheostat. Then start the genset, and bring it to rated speed. Adjust the voltage to the desired value.
7. Close the output circuit breaker. Then check the generator voltage and voltage regulation. Apply load in steps until the rated load is reached.
8. Check for vibration levels at no load and rated load. A slight increase is normal. As the load is maintained for 2-3 hours, the vibration levels will gradually increase and reach a final level.

## **Initial startup: Generators with automatic voltage control only (generator has an automatic voltage regulator (AVR) with no auto-manual switch)**

1. Disconnect the generator output from the load by opening the main circuit breaker.
2. Turn the voltage adjust rheostat fully counterclockwise. Start the prime mover, and bring the set to rated speed. Turn the voltage adjust rheostat to obtain the desired voltage.
3. Close the output circuit breaker, and apply load in gradual steps until the rated load is reached. Note the voltage regulation with the changes in load steps.
4. Check for vibration levels at no load and rated load. A slight increase is normal. As the load is maintained for 2-3 hours, the vibration levels will gradually increase and reach a final level.

## Restoring residual magnetism/field flashing

The direct current necessary to magnetize the revolving field is obtained from the exciter. Upon starting the generator, current and voltage is induced into the exciter by the magnetic lines of force set up by residual magnetism of the exciter field poles. Residual magnetism of the exciter field poles may be lost or weakened by a momentary reversal of the field connection, a strong neutralizing magnetic field from any source, or non-operation for a long time. If the generator fails to generate voltage after it has come up to rated speed, it may be necessary to restore residual magnetism.

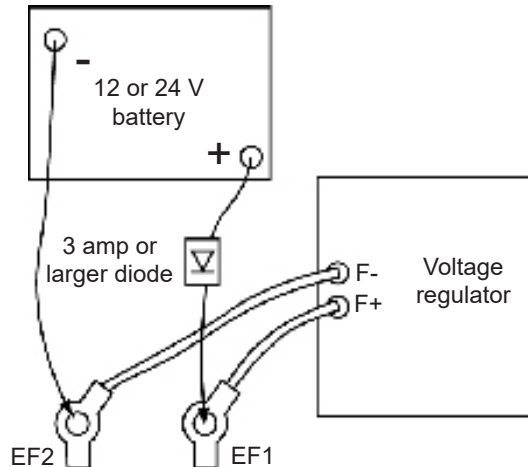

**Note:** If the polarity of the exciter is reversed by flashing the field, it may be corrected by interchanging the battery leads.

Figure 12: Field flashing setup with the field wires connected to the regulator

To restore the small amount of residual magnetism necessary to begin the voltage build up, connect a 12 or 24-volt battery to the exciter field coil circuit and flash as follows:

1. Open the output circuit breaker, and stop the engine.
2. Disconnect the exciter field coil wires EF1 at the terminal EF1 and EF2 at the terminal EF2, and connect the battery positive lead to the field coil lead EF1.
3. Flash the field by touching the battery lead to the field coil circuit terminal EF2.
4. Disconnect the battery leads.
5. Reconnect the field coil lead EF1 to terminal EF1, and reconnect the field coil lead EF2 to terminal EF2.
6. Start the generator, and check for voltage build up. Reflash if the generator output voltage does not build up, or flash with the generator running, the field coil wires connected to the regulator, and a 3-amp or larger diode off the positive terminal of the battery per Figure 12.

## Continuous operation

Operate the generator within the nameplate values. If the generator is operated below the rated power factor and voltage, decrease the kVA to prevent overheating of the field and stator windings. Consult the factory for de-rating factors if the application requires the unit to be operated beyond nameplate values.

Rotor overheating may occur when the generator is carrying excessive unbalanced loads. Negative sequence currents flowing in the field pole face cause the rotor heating. For a general guide to the allowable phase unbalance, see Figure 13, Guide to allowable phase unbalance (which is based on a 10% equivalent negative sequence current).

The guide is used in the following manner: Find the point where the vertical line (determined by the maximum current in any of the phases and expressed in percent of rated current) crosses the horizontal line (determined by the minimum current in any of the phases and expressed in percent of rated current). Ensure the point where these two lines intersect is within the permissible allowable unbalance region for safe operation of the generator.

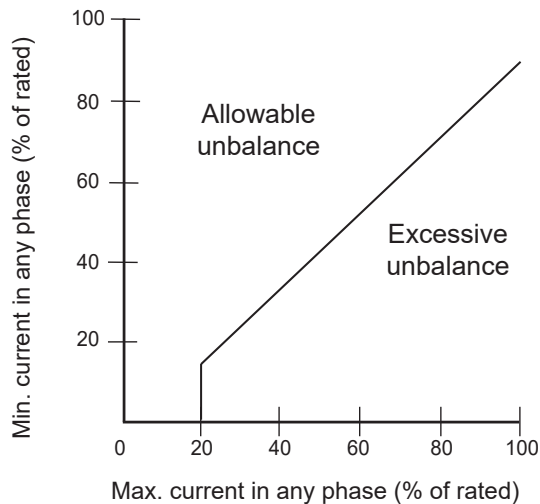

Figure 13 Guide to allowable phase unbalance

Loss of field excitation can result in the unit operating out of synchronization with the system when operating in parallel. This has the effect of producing high currents in the rotor, which will cause damage very quickly. Protective relays should be considered to open the circuit breaker.

## **Idling**

Unless the voltage regulator has V/Hz protection built in, having the generator set in operating mode while idling the engine can cause permanent equipment damage. If engine adjustments require that the engine be run at idle speed and the regulator does not have V/Hz protection, make the generator regulating system inoperative during idling by one of the following methods:

When the generator is provided with a voltage shutdown switch, be sure the switch is set to the idle position while the engine is running at idle speed.

Where the generator set is provided with field circuit breakers, set the circuit breaker to the off position while the generator is running at idle speed.

Where the generator set is provided with an automatic/manual control switch that has an off position, switch it to off while the engine is running at idle speed.

Where the generator set does not have any of the above options, remove the wires from the voltage regulator input power terminals when the engine is running at less than rated speed.

## **Parallel operation**

For the generator to operate in parallel with a system in operation, the phase sequence of the generator must be the same as that of the system. Use transformers to reduce the voltage to an acceptable level, and then use a phase rotation meter or incandescent lamp method, described in electrical machinery handbooks, for a phase sequence check.

The output voltage at the paralleling point must be the same each instant, which requires that the two voltages be of the same frequency, same magnitude, same rotation, and in coincidence with each other.

Voltmeters indicate whether the voltage magnitude is the same, and frequency meters indicate whether the frequencies are the same. Whether the voltages are in phase and exactly at the same frequency is indicated by a synchroscope or by synchronizing lamps.

A synchroscope can be used to indicate the difference in phase angle between the incoming machine and the system. The generator can be paralleled by using incandescent lamps connected as shown in Figure 14. The voltage rating of the series lamps must equal the voltage rating of the transformer-low voltage winding.

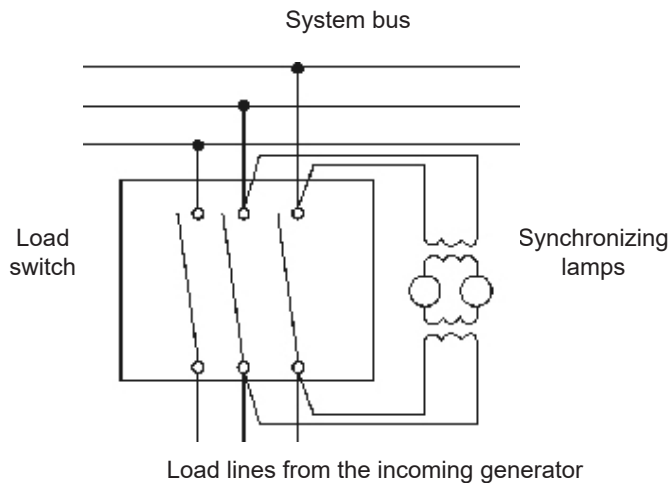

Figure 14: Synchronizing paralleled generators with test lamps

Each prime mover in the system must have the same speed regulating characteristics, and the governors must be adjusted to give the same speed regulation as determined by applying load that is proportional to the full load rating of the generator.

The voltage regulator must include paralleling circuitry. In addition, the voltage, droop settings and the V/Hz regulation characteristics must be the same for all the voltage regulators. This will allow the generators to properly share reactive loads.

If cross-current compensation is used, paralleling current transformers must give the same secondary current.

Current transformer secondary windings provide reactive kVA droop signal to the voltage regulator. Accidental reversal of this electrical wiring will cause the voltage to attempt to rise with load rather than droop. If this occurs during paralleling, stop the unit and reverse the wires at the voltage regulator terminals.

If the set is provided with a unit/parallel switch, set the switch to the parallel position on the unit being synchronized.

Synchronize the generator by adjusting the speed (frequency) slightly higher than the system. Observe the synchroscope or the lamps. The lamps should fluctuate from bright to dark at the rate of one cycle every 2 to 3 seconds. When the generator is in phase (the lights will be dark), close the circuit breaker. Immediately after closing the breaker, measure the line current kVAR of the generator. The readings must be within the rating of the unit. A high ammeter reading accompanied by a large kW reading indicates faulty governor control. A high ammeter reading accompanied by a large kVAR unbalance indicates problems with the voltage regulator. Adjusting the cross current or voltage droop rheostat should improve the sharing of kVAR.

To shut down the generator operating in parallel, gradually reduce the kW load by using the governor to reduce speed. When kW load and line current approach 0, open the generator circuit breaker. Operate the generator unloaded for several minutes to dissipate the heat in the windings. Refer to the prime mover manual for shutdown and cool-down procedures.

**Warning:** Do not service the generator or other electrical machinery without de-energizing and tagging the circuits as out of service. Dangerous voltages are present, which could cause serious or fatal shock.

**Note:** 8,000 hours is the standard interval for mineral oils @ 85°C maximum operating temperature and synthetic oils @ 95°C maximum operating temperature. Reduce the oil change intervals by half for every 10°C over these temperatures.

**Note:** For units that came with an oil cooler and filter assembly, see the Oil filter change instructions and the bearing manual that was furnished with your generator

# Maintenance

## Schedules

A regular preventive maintenance schedule will ensure peak performance, minimize breakdowns and maximize generator life. The schedule listed below is a guide for operating under standard conditions. Specific operating conditions may require reduced or increased maintenance intervals. Also, if there is a different or more specific schedule for your generator than the schedule provided below, it will be included as a supplement to the manual package.

### Every day

Visually check generator bearing housings for any sign of oil seepage.

Check the operating temperatures of the generator stator windings.

Check the control panel voltmeter for proper stability and voltage output.

Monitor the power factor and generator loading during operation.

With generators that have sleeve oil bearings, check the operating temperatures and sight glass levels (if applicable).

### Every week

Visually inspect the bearing exterior for dirt, and clean if necessary.

Inspect any generator air filters for build up of contaminants, and clean or replace as required

### Every 2000 hours or 6 months of operation

Remove generator outlet box cover. Visually inspect the stator output leads and insulation for cracking or damage. Check all exposed electrical connections for tightness. Check transformers, fuses, capacitors, and lightning arrestors for loose mounting or physical damage. Check all lead wires and electrical connections for proper clearance and spacing.

Clean the inside of the outlet box, air screens, bearing housings, and air baffles with compressed air and electrical solvent if needed.

With generators that have ball or roller bearings, check machine vibrations and bearing condition with a spectrum analyzer or shock pulse.

Regrease the regreaseable-type bearings. With generators that have sleeve oil bearings, inspect bearing oil for proper levels and clarity.

### Every 8000 hours or 1 year of operation

Check insulation resistance to ground on all generator windings,

including the main rotating assembly, the main stator assembly, the exciter field and armature assemblies, and the optional PMG assembly.

Check the space heaters for proper operation.

Check the rotating rectifier connection tightness.

With generators that have sleeve oil bearings, replace the bearing oil. With generators that have an oil cooling and filter system, replace the oil filter. See the oil cooler maintenance addendum included with this manual.

**Every 20,000 hours or 3 years of operation**

With generators that have sleeve oil bearings, perform a sleeve bearing inspection to include the removal of the upper bearing housing and bearing liner to inspect the liner, shaft journal, and seal surfaces for wear or scoring.

Remove the endbrackets, and visually inspect the generator end windings for oil or dirt contamination. Excessive contamination may necessitate surface cleaning with compressed air and electrical solvent.

Inspect the fan and fan hub for damage.

**Every 30,000 hours or 5 years of operation**

(Contact Kato Engineering for assistance)

Disassemble the generator.

Clean the generator windings using either (depending upon the severity of contamination) 1) compressed air and electrical solvent or 2) degreaser and high pressure hot water wash. Dry the windings to acceptable resistance levels (see the dry out procedure).

Inspect the rotor shaft bearing journals for wear or scoring.

With generators that have ball or roller bearings, replace the bearings.

With generators that have sleeve bearings, replace the bearing liners and oil seals.

**Note:** 8,000 hours is the standard interval for mineral oils @ 85°C maximum operating temperature and synthetic oils @ 95°C maximum operating temperature. Reduce the oil change intervals by half for every 10°C over these temperatures.

**Note:** For units that came with an oil cooler and filter assembly, see the Oil filter change instructions and the bearing manual that was furnished with your generator

**Note:** Rotor removal should be performed only as necessary and based on the level of contamination and / or a low Insulation Resistance value.

## Maintenance procedures

### Visual inspection methods of windings

Electric machines and their insulation systems are subjected to mechanical, electrical, thermal and environmental stresses that give rise to many deteriorating influences. The most significant of these are the following:

Thermal aging: This is the normal service temperature deteriorating influence on insulation.

Over temperature: This is the unusually high temperature of operation caused by conditions such as overload, high ambient temperature, restricted ventilation, foreign materials deposited on windings, and winding faults.

Overvoltage: This is an abnormal voltage higher than the normal service voltage, such as caused by switching or lightning surges or non-linear loads. Operating above rated nameplate voltage will reduce insulation life.

Contamination: This deteriorates electrical insulation by 1) conducting current over insulated surfaces 2) by attacking the material to reduce electrical insulation quality or physical strength, or by 3) thermally insulating the material so the generator operates at higher than normal temperatures. Such contaminants include water or extreme humidity, oil or grease including unstable anti-wear and extreme pressure lubricants, conducting and non-conducting dusts and particles, industrial chemicals such as acids, solvents, and cleaning solutions.

Physical damage: This contributes to electrical insulation failure by opening leakage paths through the insulation. Physical damages can be caused by physical shock, vibration, over-speed, short-circuit forces or line starting, out-of-phase paralleling, erosion by foreign matter, damage by foreign objects and thermal cycling.

Ionization effects: Ionization (corona), which may occur at higher operating voltages, is accompanied by several undesirable effects such as chemical action, heating, and erosion.

To achieve maximum effectiveness, a direct visual inspection program initially to those areas that are prone to damage or degradation caused by the influences listed above. The most suspect areas for deterioration or damage are 1) ground insulation, which is insulation intended to isolate the current carrying components from the non-current bearing components, and 2) support insulation, which includes blocks and slot wedges and are usually made from compressed laminates of fibrous materials, polyester, or similar felt pads impregnated with various types

of bonding agents. Check for the following:

Deterioration or degradation of insulation from thermal aging:

Examination of coils reveal general puffiness, swelling into ventilation ducts, or a lack of firmness of the insulation, suggesting a loss of bond with consequent separation of the insulation layers from themselves or from the winding conductors or turns.

Abrasion: Abrasion or contamination from other sources, such as chemicals and abrasive or conducting substances, may damage coil and connection surfaces.

Cracking: Cracking or abrasion of insulation may result from prolonged or abnormal mechanical stress. In stator windings, looseness of the bracing structure is a certain sign of such phenomena and can itself cause further mechanical or electrical damage if allowed to go unchecked.

Erosion: Foreign substances impinging against coil insulation surfaces may cause erosion.

**Cleaning**

Exterior: Wipe loose dirt from the exterior with a clean, lint-free cloth. Remove stubborn accumulations of dirt with a detergent or solvent that won't damage the paint or metal surfaces. Use a vacuum to clean ventilating ports.

**Warning:** *When using cleaning solvents, ensure adequate ventilation and user protection.*

Windings, assembled machines: Where cleaning is required at the installation site and complete disassembly of the machine is unnecessary or not feasible, pick up dry dirt, dust or carbon with a vacuum cleaner to prevent the redistribution of the contaminant. A small non-conducting nozzle or tube connected to the vacuum cleaner may be required to reach dusty surfaces or to enter into narrow openings. After most of the dust has been removed, a small brush can be affixed to the vacuum nozzle to loosen and allow removal of dirt that is more firmly attached.

After the initial cleaning with a vacuum, compressed air may be used to remove the remaining dust and dirt. Compressed air used for cleaning must be clean and free of moisture or oil. Air pressure or velocity must be adequately controlled to prevent mechanical damage to the insulation.

Disassembly of the machine and more effective cleaning by a qualified Kato technician may be required if the above described field service cleaning procedures do not yield effective results.

Windings, disassembled machines: Take an initial insulation resistance reading on the machine to check electrical integrity. The high pressure hot water wash method of cleaning, which sprays a high velocity jet of hot water and water containing a mild detergent, is normally effective in cleaning windings, including those subjected to flooding or salt contamination. Use multiple sprays with clean water to remove

**Caution:** The insulation resistance tests are usually made on all or parts of an armature or field circuit to ground. They primarily indicate the degree of contamination of the insulating surfaces or solid insulation by moisture and other conducting influences and will not usually reveal complete or uncontaminated ruptures.

**Note:** The insulation resistance value increases with decreasing winding temperatures. All readings must be corrected to winding temperatures. Use Table 4 for converting megger readings to other temperatures (e.g., 100 megohms at 50° C is converted to 170 megohms: 1.7 x 100).

Winding Temp (°C)	Conversion factor
10	0.23
20	0.37
30	0.6
40	1
50	1.7
60	2.7
70	4.5
80	7.5
90	14
100	23
110	38
120	61

Table 4: Temperature conversion factor for resistance readings

**Warning:** Never apply the megger to the rotating rectifier, the voltage regulator, or generator accessories (e.g., temperature detectors, space heaters).

**Note:** New generators should measure about 100 megohms minimum of insulation resistance when meggered. Generators that read 50 megohms or less should be dried out according to the dry out procedures here. Generators with insulation resistance readings of 10 megohms or less should be investigated.

or dilute the detergent following the detergent spray. Dry the machine until acceptable insulation resistance values are obtained at room temperature. See the insulation resistance procedures below for minimum recommended values.

Electrical contacts: Clean electrical contacts, switch contacts and terminals with an approved contact cleaner. Do not file contacts.

### Insulation resistance tests at low voltage

Insulation tests are conducted for two reasons: to discern existing weakness or faults or to give some indication of expected service reliability. Insulation resistance tests are based on determining the current through the insulation and across the surface when a DC voltage is applied. The leakage current is dependent upon the voltage and time of application, the area and thickness of the insulation, and the temperature and humidity conditions during the test.

Refer to the following electrical measurement procedures for testing detail. Contact Kato Engineering or refer to IEEE Standard. 432-1992 when more extensive insulation tests are required

When checking insulation resistance with a megger, first verify the ground path. Connect one test lead to a ground point. Then connect the second test lead to another ground location to prove the ground connection. Once the ground path has been proven, the second test lead can be connected to the leads of the component to be tested.

### Exciter field (stator) and PMG armature (stator)

1. Disconnect the exciter leads from the terminals in the terminal box or the voltage regulator.
2. Connect exciter leads to one clamp of 500-volt megger, and connect the other clamp to the exciter field frame.
3. Apply 500 V from the megger, and measure the resistance reading after 1 minute. The reading must be a minimum of 50 megohm. If it is not, refer to the cleaning or dry out procedures.
4. Ground the exciter field leads to the exciter field frame for several minutes after the megger has been disconnected. This will allow the voltage build up to be properly discharged.
5. Repeat steps 1-4 for the PMG armature (stator).

### Exciter armature

1. Disconnect the exciter armature leads from the rotating rectifiers.

2. Connect the leads of the exciter armature to one clamp of a 500-volt megger, and connect the other clamp to a suitable connection on exciter sleeve or shaft.
3. Apply 500 V from the megger, and measure the resistance reading after 1 minute. The reading must be a minimum of 50 megohms. If it is not, refer to the cleaning or dry out procedures.
4. Ground the exciter leads to the exciter sleeve or shaft after disconnecting the megger. This will allow the voltage build up to be properly discharged.

Main rotor

1. Disconnect the generator field leads from the positive and negative terminals of the rotating rectifier assembly.
2. Connect the positive and negative leads to one clamp of the megger, and connect the other clamp to the shaft.
3. Apply voltage from the megger, and measure the resistance reading after 1 minute. The reading must be a minimum of 50 megohms. If it is not, refer to the cleaning or dry out procedures. (See Table 5).
4. Ground the field leads to the shaft after disconnecting the megger for a minimum of 1 minute. This will allow the voltage build up to be properly discharged.

Main stator

1. Disconnect power connections and all control apparatus from the generator terminals.
2. Measure insulation resistance of each phase separately with the two other phases shorted to the frame.
3. Use a megger connected between the lead(s) of the phase to be measured and generator frame. The minimum 1-minute insulation resistance must not be less than 50 megohms. (See Table 5).
4. Ground the leads to the frame after the 1-minute megger test. This will allow the voltage build up to be properly discharged.

**Dry out procedures**

If the insulation resistance readings are below the recommended minimum values specified previously, use one of the dry out procedures described below. Select the procedure based on the size and location of the unit, available equipment, and experience of personnel. Before drying, remove the voltage regulator, and cover all inlet and discharge

Winding rated voltage (V)*	Insulation resistance test direct voltage (V)
<1000	500
1000-2500	500-1000
2501-5000	1000-2500
5001-12000	2500-5000
>12000	5000-10000

Table 5  
Guidelines for DC voltages to be applied during insulation resistance tests

<sup>a</sup> Rated line-line voltage for three-phase ac machines, and line-to-ground voltage for single-phase machines, and rated direct voltage for dc machines or field windings.

**Caution:** Do not apply heat too rapidly. It could damage the windings.

openings. Provide an opening at the top of the machine, preferably at the fan end, for moisture to evaporate.

Drying with external heat: Place heat lamps, space heaters (in addition to the ones already supplied) or a steam pipe near the windings. Monitor winding temperatures. Raise winding temperature gradually at a rate of 10-20° F (-12° to -6° C) per hour up to 200° F (93° C). Measure insulation resistance at 1-hour intervals. Typically the insulation resistance will slowly drop while the temperature is coming up, and then gradually increase and level out.

Drying with AC current in the armature: Short circuit the generator terminals. Provide DC excitation to the brushless exciter field winding. Insert a current transformer and an ammeter to read full load current. Run the generator at rated speed. Apply excitation to the exciter field until rated current is developed. Monitor winding temperatures until they stabilize. Continue running until insulation resistance values level off. Monitor winding temperatures. Raise winding temperature gradually at a rate of 10-20° F (-12° to -6° C) per hour up to 200° F (93° C). Measure insulation resistance at 1-hour intervals. Typically, the insulation resistance will slowly drop while the temperature is coming up and then gradually increase and level out.

**Note:** For units that came with an oil cooler and filter assembly, see the Oil filter change instructions and the bearing manual that was furnished with your generator

### Bearing lubrication

Sleeve bearings: Lubricate the bearings in accordance with the lubricating instructions attached to the generator and the bearing lubrication instructions, which are provided in the manual package as supplementary material.

Roller bearings: In applications where regreaseable bearings are used, grease fill fittings and relief valves are incorporated into the bearing housing. Lubricate the bearings in accordance with the lubricating instructions attached to the generator.

### Rectifier tests

If a failure of a rectifier is suspected, remove the exciter cover. Remove the nut and washer holding the rectifier in the heat sink, and remove the diode lead wire. Lift the rectifier from the heat sink (see figure 20 for an overview). Test the entire rectifier with an ohmmeter or test lamp as follows:

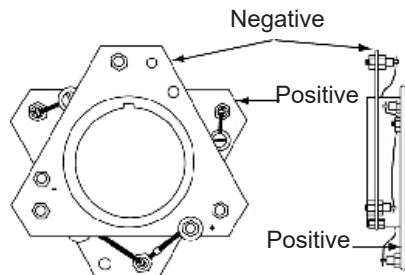
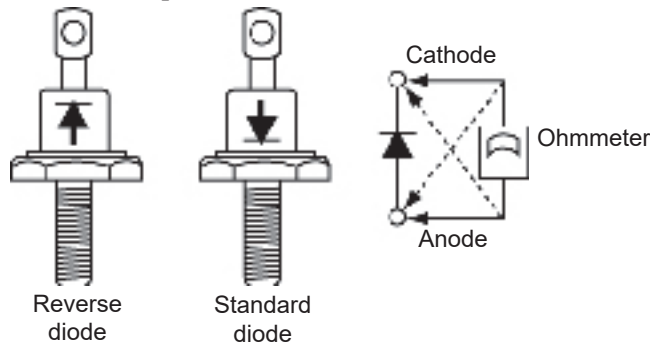

Figure 20: Rectifier

Ohmmeter: Connect the ohmmeter leads across the rectifier in one direction (see Figure 21). Note the meter reading. Reverse the leads, and note the meter reading. The meter should indicate a low resistance when the leads are across the rectifier in one direction and a high resistance when the leads are across the rectifier in the opposite direction. A low resistance in both directions indicates a short. A high resistance in both directions indicates an open rectifier.



**Caution:** Do not pound on the rectifier or armature windings.

Figure 21: Testing the rotating rectifier with an ohmmeter

Test lamp: Connect the leads of a test lamp, consisting of standard flashlight batteries and a flashlight and built, as shown in Figure 22, across the rectifier in one direction. Then reverse the leads. The light should light in one direction but not the other. If the light lights in both directions, the rectifier is shorted. If the light does not light in either direction, the rectifier is open.

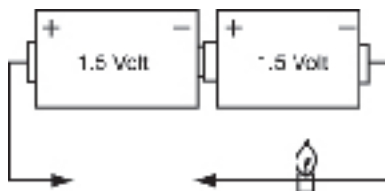

Figure 22: Test lamp

Replace defective rectifiers with rectifiers of the same operating characteristics as rectifiers installed in the generator at the factory. Order rectifiers by part number, including the model and type of exciter as well as the generator serial number.

Surge protectors may be included on the rotating rectifier assembly. Disconnect one lead of the surge protector, and connect the leads of an ohm meter or makeshift test lamp, consisting of standard flashlight batteries and a flashlight and built as shown in Figure 21, across the surge protector in either direction. If the light comes on, the surge protector is defective. Order surge protectors by part number, including the model and type of exciter as well as the generator serial number. Following replacement, make sure that the revolving field, exciter armature, and rotating diode leads are properly secured.

**Note:** The following procedures are meant to be a general guide. Procedures for your unit may vary.

**Warning:** Ensure the generator has stopped and is de-energized before disassembly.

**Warning:** Use a hoist and slings or chains to support the components during removal. Use lifting devices that are selected for generator component weights. Be extremely careful not to damage components.

**Caution:** Ensure the generator field wires

**Caution:** Ensure the generator field wires are flat in the wireway so they don't tear during pulling. Do not pull on the edges of the heat sinks or on the exciter armature windings.

**Warning:** Pull the exciter-PMG frame-stator straight out. The assembly may pull toward the PMG.

**Caution:** Do not pull on the edges of the rectifier or on the exciter armature windings.

**Note:** For units that came with an oil cooler and filter assembly, see the Oil filter change instructions and the bearing manual that was furnished with your generator

## Assembly and disassembly of generator

### Disassembly

Remove the outlet box covers and disconnect the generator load leads. Tag the leads and terminals to make certain the leads are correctly connected when the unit is reassembled. Disconnect the other electrical connections (current transformers, potential transformers, RTDs, AVR and governor power supply inputs and outputs, and space heaters).

Shut down the oil supply system, and disconnect it from the generator. (if applicable).

Loosen or remove the bolts (as needed) from the coupling to separate the coupling halves.

Remove the PMG.

1. Remove the exciter cover.
2. Disconnect the alternator field leads, and remove the exciter armature and PMG retaining bolts.
3. Install a wire or metal strap around the OD of the PMG to ground the magnets. Grasp the inside magnets and pull quickly and sharply straight back, overcoming the magnetic pull of the PMG rotor toward the PMG armature.
4. Wrap the PMG rotor in plastic to avoid contamination with metal filings.

Remove the exciter armature and rectifier as a unit.

1. Remove the clips securing the exciter field leads to the exciter frame, the generator frame and generator endbell.
2. Disconnect the generator field (rotor) leads from the positive (+) and negative (-) exciter armature lead terminals located on the rotating rectifier assembly.
3. Using a hoist and strap, slide out and remove the exciter armature and rectifier tube assembly, which is keyed onto the shaft.

Remove the exciter-PMG frame-stator.

1. Connect a hoist to the lifting eyes.
2. Remove the exciter-PMG frame-stator mounting bolts, and remove the exciter-PMG frame-stator.

Remove the opposite-drive end bracket.

Dismantle the bearings.

1. Twist the knob on the spring-loaded holders, and pull the RTDs out of the bearing hanger
2. Dismantle all air tubes and oil supply lines. With units with oil cooler assemblies, see the oil cooler addendum that came with this manual.
3. Dismantle the outboard seal carrier and inboard seal carrier.
4. Loosen the bolts that connect the carriers to the housing, and remove them.
5. Loosen and remove the split line bolts.
6. Remove simultaneously, in the axial direction, both the top and bottom halves of the seal carriers.
7. Remove the garter springs and the gap seal and labyrinth seal.
8. Remove the gasket.

Dismantle the top half of the bearing housings.

1. Remove the split-line bolts.
2. On the opposite-drive-end side, lift the top part of the bearing housing until it can be moved in an axial line over the bearing liner without touching it, and then move it out.
3. On the DE side lift the housing out and over the top of the generator.
4. On the opposite-drive-end side, unscrew the split line screws in the bearing liners. Screw in two lifting eyes in the top, and lift the top half off the bearing liners.
5. Lift the shaft up slightly (about 0.015 to 0.25 inch) on both ends of the rotor to the point where the shaft and bottom half of the bearing liner do not touch each other.

**Caution:** Make sure that the work place is clean. Contamination and damage to the bearing, especially of the running surfaces, reduce operating quality and could lead to premature damage or failure.

**Note:** If necessary, tap the bearing housing lightly with a rubber or fiber mallet to loosen it.

**Note:** The outside seal carrier on the drive end bearing does not have split line bolts.

**Caution:** Be careful to not damage running surfaces.

**Warning:** Before transport or lifting bearing components, check if the eye bolts are tight. Insecure eyebolts could result in the part coming loose and falling. Make sure the eyebolts are not exposed to bending stress, otherwise they could break. Make sure the lifting equipment does not contact the seal and running surfaces of the shaft.

**Note:** On the DE side, you can remove the bearing liners after the rotor has been removed.

**Caution:** Make sure the RTD is removed before rotating the bearing liner.

**Caution:** Make sure the pipe is strong enough to support the weight of the rotor and that it does not have rough edges on the inside, which could damage the shaft. To prevent tension on the shaft, put slings around the largest shaft step possible. Make sure the rotor does not hit the stator.

**Note:** If the generator is mounted on the engine base, the drive end bearing bracket and air baffle may not be able to be removed until the rotor passes through the generator.

6. Place shims between the rotor and the stator the thickness of the air gap. Lower the shaft.
7. On the opposite-drive-end side, remove the bottom halves of the bearing liners.
8. Rotate the bottom half of the liner 180° so it is facing upward (where the top half of the liner was). Move the shaft as necessary. Slide the liner forward so it rests on the bottom bearing housing's top surface.
9. Use lifting eyes and hoist to remove the liner.
10. Remove the bottom half of the bearing housings from the frame.
11. Remove the opposite-drive end bearing bracket and air baffle.

Float out the rotor.

1. Fit a pipe over the shaft. Depending upon the space available, you may have to use a pipe that can be assembled, adding an additional piece during each stage of movement outward.
2. Attach slings around the pipe on one end and around the shaft on the opposite end.
3. Lift up the rotor, and move it out, gently resting the rotor on the stator as the slings are moved down the pipe for the next lifting stage. (See figure 23).
4. Remove the drive-end side bearing liners from the shaft.

## Assembling the generator:

Use standard torque specifications per Chart 1 unless otherwise specified.

Install the bearing liners on the drive-end side of the shaft.

1. Make sure the surfaces are clean. Apply STP Oil Treatment over the running surface on the shaft where the liner will sit.
2. Make sure the engraved numbers on the top and bottom halves correspond and are on the same side. Mate the top liner over the bottom liner on the shaft.
3. Put Loctite 242 on the split line screws, insert the screws, and tighten.

Float in the rotor.

1. Move the rotor up and in line with the stator. Fit a pipe over the drive end of the rotor. Depending upon the space available, you may have to use a pipe that can be disassembled, taking off an additional piece during each stage of movement inward.
2. Attach slings around the pipe on one end and around the shaft on the opposite end.
3. Lift up the rotor, and move it in, gently resting the rotor on the stator as the slings are moved down the pipe

Put a bead of premium siliconized acrylic latex caulk (or equivalent) over the opposite-drive-end baffle mating surface, and install the baffle.

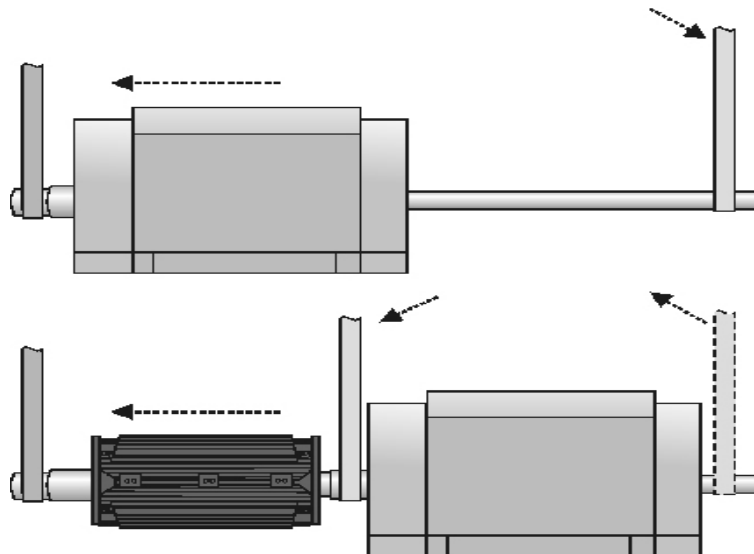

Figure 23: Floating the rotor

**Caution:** Make sure all components are clean before assembly. Make sure all gaskets have not deteriorated and are positioned correctly.

**Caution:** Make sure the pipe is strong enough to support the weight of the rotor and that it does not have rough edges on the inside, which could damage the shaft. To prevent tension on the shaft, put slings around the largest shaft step possible. Make sure the rotor does not hit the stator.

**Caution:** Make sure all components are clean before assembly.

**Note:** Torque fasteners to the values specified in Chart 1 unless otherwise specified.

**Caution:** Carry out these operations very carefully as to not damage the shaft or bearing components.

**Caution:** Remove all impurities or other objects such as screws, nuts, etc., from the bearing components. If left inside, they could lead to bearing damage. To prevent contamination, cover the bearing components when they are not being worked on.

**Note:** If no fixture is available to compress the insulators, use the top liner for both halves of the bearing. Make sure all tubes and fasteners are in the liner to ensure a smooth surface.

Assemble the bearings as follows:

Install the liner insulators on the inside diameter of the top and bottom bearing housing of both bearings. Each housing gets two insulators.

1. Fit up the insulators in the liner seat, and crease the outside edge over the lip.
2. Trim the top of the insulators flush with the mating surface (of the top and bottom halves of the housing).
3. Make sure the insulator surface is clean. Mix Metallon two-part epoxy in equal parts, and brush it over the track.
4. Peel the backing off, and put the insulators in place. Press them tightly on the track, and place the liners (or fixtures) in the housings to maintain good compression. Let the epoxy set for 12 hours. Make sure it has no voids or air bubbles.

Install the bottom bearing housings. Before installing, brush Nox rust on frame mating surfaces that will fit into bearing housing.

1. On the opposite-drive-end side, lift up the ends of the shaft slightly, so the bearing housing clears the shaft, and bolt it in place on the frame.
2. On the drive end side, lift the housing up and bolt it into place on the frame.

Install the bottom half of the bearing liners on the opposite-drive-end side.

1. Lift the shaft up slightly (about 0.005 inch) on both ends of the rotor to the point where shaft and bottom half of the liner do not touch each other.
2. Make sure the surfaces are clean. Apply STP Oil Treatment over the running surface on shaft where the liner will sit.
3. Set the liner on the shaft so it rests on the housing. Use eyebolts for lifting. The ID numbers on the lining face outward.
4. Remove the lifting eyes from the liner. Move the rotor gently from side to side and up and down as necessary, and slide the liner down into the housing. If the liner doesn't turn easily, check the position of the shaft and the alignment of the housing.
5. Lower the shaft onto the liner.

Install the top half of the bearing liner on the drive end side.

1. Apply STP Oil Treatment on the running surface of the shaft where the top half of the liner will sit.
2. After making sure the engraved numbers on the top and bottom halves correspond and are on the same side, place the top liner over the bottom liner.
3. Put Loctite 242 on the split line screws, insert the screws, and tighten.

Install the top bearing housings.

1. Apply STP Oil Treatment on the top of the bearing liner.
2. Spread Loctite 587 Blue on the bottom housing where it will mate with the top housing.
3. Put the top housing in place, making sure the dowel pin in the inside diameter of the top housing lines up with the pin hole in the bearing liner. Put Loctite 242 on the split lines screws, and fasten the housings together, leaving the screws snug but not tight.

Torque the split line screws to 1100 ft-lbs.

Install the seal carrier assemblies.

1. Cut the gasket, if necessary to fit it over the shaft. Coat it with Loctite Hi-Tack gasket sealant or equivalent, and fit it over the shaft.
2. Attach the gap seal and labyrinth seal with the labyrinth seal nearest the bearings. Put the two halves of the seals together, and slip the garter springs around the seals to fasten them. (The outside seal carrier on the drive end side only gets a labyrinth seal.)
3. Put Curil-T on the inside diameter of the seal carriers where they will contact the seals, (one bead in the narrow (inside) groove and one bead in each of the three wider (outside) grooves. Also put Curil-T on the surface of the labyrinth seal on both sides of the spring.
4. Use Loctite 587 Blue to caulk the mating surface of the bottom seal carrier (where it mates with the top half). Put gasket sealant on the flange surface of the seal carrier where it will mate with the bearing hanger. Also, put gasket sealant on the mating surface of the bearing hanger.

Exciter armature diameter (in.)	Minimum air gap (in.)
5 3/4	0.014
9 7/8	0.014
12 1/2	0.018
16 1/4	0.035

Table 6: Exciter air gap

**Note:** To measure air gap, measure completely around the gap between the exciter armature and exciter field with a feeler gauge. Keep the gauge at the tightest point, and turn the generator over to measure the air gap as the rotor turns.

**Caution:** Do not pry on the fan.

**Note:** For units that came with an oil cooler and filter assembly, see the Oil filter change instructions and the bearing manual that was furnished with your generator

- Set the top half of the seal carrier over the seals. Make sure the notch in the top of the seal lines up with the opening in the seal carrier. Attach the bottom half of the seal. Put Loctite 242 on the threads of the two split line screws. Add a flat washer, insert, and tighten.
- Slide the seal carrier assembly up against the gasket and bearing hanger. Bolt (with flat and lock washer) the seal carriers to the bearing hanger, and tighten.

Install the air tube and oil supply lines. Reconnect the oil cooler if applicable. (See the oil cooler addendum that came with this manual).

Install the RTDs in the spring-loaded holders.

Before operating the generator, start the oil flow to the bearings, and follow the startup procedure to ensure the bearing is functioning properly and so that damage to the bearing doesn't occur.

Brush Nox rust on frame mating surface that will fit into the opposite-drive end bracket (which fits over the top of the top bearing housing), and attach the opposite-drive end bracket and tighten.

Attach the exciter-PMG frame-stator.

- Apply Nox rust to the machined surface on the bearing bracket where the exciter-PMG frame-stator will mount.
- Attach the exciter-PMG frame-stator to the bearing bracket mounting surface.
- Torque the bolts per Chart 1.

Attach the exciter armature and rectifier tube assembly.

- Brush Nox rust on the exposed PMG shaft journal.
- Position the exciter armature-rotating rectifier assembly in line with the shaft, and turn the assembly to the position where the keyway in the exciter sleeve is in line with the key in the generator shaft.
- With hand force, push the armature assembly and rotating rectifier tube over the shaft, so the end of the sleeve is against the shoulder on the shaft. It may be necessary to tap lightly on the exciter sleeve in order to move the assembly over the key. Use a fiber or rubber mallet. If installation is still a problem, use a heat gun to expand the exciter sleeve.

4. Connect the field leads to the rotating rectifier.

Attach the PMG.

1. Brush Nox rust on the exposed PMG shaft journal.
2. Put the armature key in the slot on the shaft.
3. Align the PMG rotor with the key on the shaft and holding by the inside magnets, slide the PMG into position.
4. Install the PMG/Exciter armature retaining bolts. Torque the bolts per Chart 1.

Check the air gap between the PMG rotor and PMG stator.

1. Measure completely around the gap between the PMG rotor and PMG stator with a feeler gauge.
2. Keep the gage at the tightest point, and turn the generator over to measure the air gap as the rotor turns. Minimum air gap is 0.035 inch.

Check the air gap between the exciter armature and exciter stator.

1. Measure completely around the gap between the exciter armature and exciter stator with a feeler gauge.
2. Keep the gage at the tightest point, and turn the generator over to measure the air gap as the rotor turns. Minimum air gap is 0.035 inch.

**Caution:** *Do not pound on the rectifier.*

Attach the exciter cover.

Connect the air temperature RTDs.

Mount the generator to the prime mover, and make the electrical connections as described earlier.

**Note:** *For units that came with an oil cooler and filter assembly, see the Oil filter change instructions and the bearing manual that was furnished with your generator*

# Troubleshooting Guide (corrective maintenance)

**Warning:** Problems left uncorrected can result in injury or serious damage, which can result in costly repairs and downtime.

Between regular preventive maintenance inspections, be alert for any signs of trouble. Correct any trouble immediately.

Symptom	Cause	Remedy
No Voltage	Open voltage regulator, circuit breaker or fuses	Check. Reset the circuit breaker or replace fuses if open.
	Overvoltage, undervoltage, or overload devices tripped (when protective devices are incorporated into the circuit)	Check for the cause of the abnormal condition. Correct any deficiencies. Reset devices. Check the generator nameplate for nominal operating values.
	Open circuit in exciter field	Check continuity of shunt field and leads to voltage control. (Use ohmmeter or Wheatstone bridge) If open in field coils, remove exciter field assembly and return assembly to factory for repair.
	Loss of residual magnetism in exciter field poles	Restore residual magnetism or flash field. When the voltage regulator is a model that requires flashing, install an automatic field flashing system.
	Open circuit in stator windings	Check for continuity in the windings. Return the generator to the factory for repair if open.
	Malfunction of automatic voltage regulator	See troubleshooting of voltage regulator. Correct deficiencies.
	Short-circuited generator output leads	Clear lead to restore voltage buildup.
	Open in rotating rectifiers	Check rotating rectifiers, and replace if open.
	Open in generator field	Check for continuity and return rotor to factory for repair if field coils are open.
	Shorted or grounded surge protector	Check for shorts or grounds. Replace .
	Shorted or grounded rotating rectifier	Check for shorts grounds. Replace or repair.
	Shorted or grounded exciter armature	Check for shorts or grounds. Replace or repair.
Low voltage	Shorted leads between the exciter armature and generator field	Test and repair.
	Incorrect stator connections	Check the connections, and reconnect

Table 6: Troubleshooting

Symptom	Cause	Remedy
Low voltage (cont.)	Improper adjustment of voltage adjust rheostat	Adjust rheostat.
	Excessive load	Reduce load. With three-wire, single-phase and four-wire, three-phase generators, the load on each leg must be as evenly balanced as possible and must not exceed the rated current on any leg.
	Line loss	Increase the size of the line wire.
	High resistance connections (hot)	Make better connections.
	Shorted main or exciter field	Test the field coils for possible short by checking resistance with an ohmmeter or resistance bridge. Return the rotor assembly to the factory for repair if field coils are shorted.
	Low power factor	Reduce inductive (motor) load. Some AC motors draw approximately the same current regardless of load. Do not use motors of larger horsepower rating than is necessary to carry the mechanical load.
	Weak field due to operating in a warm temperature	Improve the ventilation of the generator. Field current can be increased providing the generator temperature rating stamped on the nameplate is not exceeded.
	Defective rectifiers in rectifier assembly (stationary)	Check rectifier assembly. Replace defective fuses or rectifiers.
	Excessive load	Reduce load to rated value.
	Bearing overheating	Inspect the bearing.
	Improper speed of engine driven generator set due to defective governor, ignition system, or carburetor	Check and correct deficiencies.
	Voltage regulator not operating properly	Check the regulator. Adjust, repair or replace.
Fluctuating voltage	Prime mover speed fluctuating	Check frequency and voltage of incoming power when the generator set is motor driven. Check engine governor on engine-driven generator sets.
	Loose internal or load connections	Tighten all connections.
	Generator overloaded	Reduce load to rated value.
	DC excitation voltage fluctuating	Trace DC excitation circuit. Correct any defects.
	Overspeed	Correct speed of prime mover.
	Voltage regulator not operating properly	Check the regulator. Adjust, repair or replace.
High voltage	Improper adjustment of voltage adjust rheostat or voltage regulator	Adjust rheostat and/or voltage regulator.
	Voltage regulator not operating properly	Check the regulator. Adjust, repair or replace.

<b>Symptom</b>	<b>Cause</b>	<b>Remedy</b>
Overheating	Clogged ventilating screens and air passages	Clean all screens and air passages.
	Dry or defective bearings	Inspect bearings.
	Coupling misaligned	Align the generator set.
	Generator field coils shorted or grounded	Test field coils for shorts. Replace shorted rotor or return it to the factory for repair.
	Unbalanced load or overload, low PF	Adjust load to nameplate rating.
Vibrations	Defective or dry bearings	Inspect bearings.
	Misalignment of generator and prime mover	Align the generator set.
	Generator not properly mounted	Check mounting. Correct defective mounting.
	Transfer of vibration from another source	Isolate the generator set from the source of vibration.

## ASTM and SAE Torque Values

SCREW SIZE	Grade 2				Grade 5				GRADE 8				Grade 8			
	Foot-Pounds		Newton-Meter		Foot-Pound		Newton-Meter		Foot-Pound		Newton-Meter		Foot-Pound		Newton-Meter	
	Ft-Lbs	Tol	N-M	Tol	Ft-Lbs	Tol	N-M	Tol	Ft-Lbs	Tol	N-M	Tol	Ft-Lbs	Tol	N-M	Tol
#4-40	4 *		0.4													
#6-32	8 *		0.9													
#8-32	14 *		1.6													
#10-24	20 *		2.3													
#10-32	23 *		2.6													
1/4-20	4	1	6	1	8	2	11	3	5	1	7	2	10	2	14	3
5/16-18	8	2	11	2	17	3	24	4	10	2	14	3	25	5	34	7
3/8-16	15	3	20	4	31	6	42	8	12	2	16	3	40	10	54	14
7/16-14	24	5	32	6	50	10	65	13					70	15	95	20
1/2-13	36	7	50	10	75 **	15	100	20	24	5	32	6	100	20	135	27
9/16-12	55	10	75	14	110	20	150	25					150	30	200	40
5/8-11	75	12	100	17	150	25	200	20					200	40	275	55
3/4-10	130	25	175	24	260	50	350	70					370	50	500	70
7/8-9	145	20	195	28	425	60	575	80					600	60	800	80
1.0-8	190	22	250	30	650	75	875	100					900	90	1200	120
1 1/8-7	265	27	350	35	790	80	1075	100					1200	120	1650	180
1 1/4-7	375	40	500	55	1100	120	1500	150					1750	180	2400	250
1 3/8-6	490	50	650	70	1450	150	1950	200					2300	230	3100	300
1 1/2-6	625	60	850	90	1750	180	2350	250					3000	300	4000	400

\* Inch-pounds

SCREW SIZE	Set Screws				Brass Screws				Stainless Screws				Grade 8 Top Lock Nuts			
	Foot-Pounds		Newton-Meter		Foot-Pound		Newton-Meter		Foot-Pound		Newton-Meter		Foot-Pound		Newton-Meter	
	Ft-Lbs	Tol	N-M	Tol	Ft-Lbs	Tol	N-M	Tol	Ft-Lbs	Tol	N-M	Tol	Ft-Lbs	Tol	N-M	Tol
#4-40					4 *		0.4		5 *		0.6					
#6-32					8 *		0.9		10 *		1.1					
#8-32	20 *		2.3		16 *		1.8		21 *		2.4					
#10-24					18 *		2		24 *		2.7					
#10-32	34 *		3.8		33 *		2.9		33 *		3.7					
1/4-20	6	1	9	2	5	1	7	2	6	1	8	2	6	1	8	1
5/16-18	13	2	18	3	9	2	12	2	11	2	15	3	11	2	15	3
3/8-16	23	2	31	6	16	3	22	4	21	4	28	5	18	2	24	3
7/16-14	36	5.14	50	10	26	5	35	7	33	7	45	9	28	4	38	5
1/2-13	50	10	70	14	35	7	45	9	45	9	60	12	44 **	6	60	12
9/16-12					55	10	70	13	60	11	80	15				
5/8-11	110	18	145	24	85	14	115	19	100	17	140	23				
3/4-10	180	35	240	46	120	23	160	31	130	25	180	35				
7/8-9	430	60	580	82					205	30	280	40				
1.0-8	580	70	790	90					300	35	400	45				
1 1/8-7									430	45	590	60				
1 1/4-7									550	60	750	80				
1 3/8-6									700	70	950	100				
1 1/2-6									930	100	1250	130				

\* Inch-pounds

\*\* For Electrical Lugs use 44 Ft-lbs (60 N-M)

Chart 1: Torque Values

## Metric Torque Values

SCREW SIZE	Grade 4.8 to 6.8				Grade 6.9 to 8.8				Grade 8.8 GASKETED COVERS				Grade 10.9			
	Foot-Pounds		Newton-Meter		Foot-Pound		Newton-Meter		Foot-Pound		Newton-Meter		Foot-Pound		Newton-Meter	
	Ft-Lbs	Tol	N-M	Tol	Ft-Lbs	Tol	N-M	Tol	Ft-Lbs	Tol	N-M	Tol	Ft-Lbs	Tol	N-M	Tol
M4 x .70	1.1		1.5		2		2.7						2.9			
M5 x .80	2.3		3.1		4		5.3						6			
M6 x 1.00	4	1	5.2	1	7	1	9.3	2	4	1	5	1	10	2	14	3
M7 X 1.00	6.5	1	8.7	2	11	1	15	3					16	5	34	7
M8 x 1.25	10	2	13	3	18	2	24	5	11	2	15	4	25	10	54	14
M10 x 1.50	20	4	27	5	32	4	43	9	13	3	18	4	47	15	95	20
M12 x 1.75	34	7	45	9	58	7	77	15	19	4	26	5	83	20	135	27
M14 x 2.00	54	10	72	13	94	10	125	23					132	30	200	40
M16 x 2.00	80	13	108	18	144	13	192	32					196	40	275	55
M18 x 2.50	114	22	152	29	190	22	253	50					269	50	500	70
M20 x 2.50	162	23	216	30	260	23	347	50					366	60	800	80
M22 x 2.50	202	23	269	31	368	23	491	55					520	90	1200	120
M24 x 3.00	245	25	327	33	470	25	627	65					664	120	1650	160
M27 x 3.00	360	40	480	52	707	40	943	100					996	180	2400	250
M30 x 3.50	500	50	667	70	967	50	1289	130					1357	230	3100	300

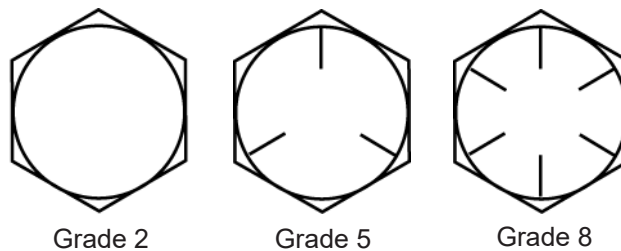

ASTM & SAE grade markings

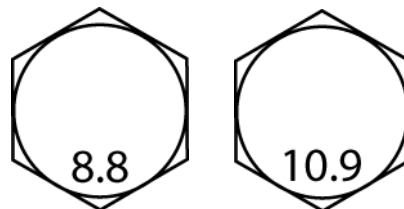

Class 8.8      Class 10.9  
Metric grade markings

1-NM = 0.737 ft-lbs. = 8.85 in-lbs.

# List of equipment required for installation and maintenance

## Test equipment

Ammeter  
Multimeter  
Thermometer  
Megger  
Resistive Bridge

## Notes

Clamp-on, 0 to 500 amp range for measuring of electrical current.  
Digital, for measuring voltage, current, frequency and resistance.  
For measuring temperature in Celsius  
To measure insulation resistance.  
To measure resistance of windings.

## Special tools

Bearing puller  
Exciter puller

For changing bearing.  
For pulling exciter armature

## Standard tools

Cable tool  
Flashlight  
Grease gun  
Hammer  
Lamp (incandescent)  
Screwdrivers  
Screwdrivers  
Wrench  
Wrench  
Wrench set  
Wrench set  
Wrench set  
Vacuum

Crimping  
As required  
For lubricating bearings  
Soft-faced  
Safety light  
Standard, sized as required  
Phillips, sized as required  
Adjustable, 12-inch  
Torque 0 to 100 ft-lb  
Allen, 1/8 to 1/2 inch  
Socket, 1/4 to 1 inch with 3/8 and 1/2 inch drive  
Standard, open-end/box-end combination sized 1/4 to 1 inch  
Electric with nonmetallic nozzle

## Materials

Air  
Corrosion inhibitor  
Covering material

Detergent  
Gloves  
Gloves  
Heaters

Plastic  
Rags  
Water  
Tags

Compressed, dry.  
Nox-Rust VC #10 Oil or equivalent  
Waterproof desiccant bags for protection from moisture during long-term equipment storage  
As required for cleaning  
Chemical-protective  
Electrical-protective  
Space Heater, for eliminating excess moisture in damp areas and dry out of motor or generator windings  
Protection for long-term storage  
As required for cleaning  
Warm and clean, for cleaning  
Warning and cautions

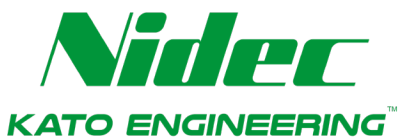

## Kato Engineering Support

The brand you trust, the power you depend on. Include the serial number and model number for your machine in the email subject line.

Field Service	<a href="mailto:KatoService@mail.nidec.com">KatoService@mail.nidec.com</a>
Parts	<a href="mailto:KatoParts@mail.nidec.com">KatoParts@mail.nidec.com</a>
Remanufacturing	<a href="mailto:KatoRemanufacturing@mail.nidec.com">KatoRemanufacturing@mail.nidec.com</a>
Warranty/Quality Assurance	<a href="mailto:KatoWarranty@mail.nidec.com">KatoWarranty@mail.nidec.com</a>

---

Kato Engineering, Inc. | P.O. Box 8447 | Mankato, MN USA 56002-8447 | Tel: 507-625-4011  
[KatoEngineering@mail.nidec.com](mailto:KatoEngineering@mail.nidec.com) | [www.KatoEngineering.com](http://www.KatoEngineering.com) | Fax: 507-345-2798