

Publication 350-03001-00, July 2005

# Instruction Manual

Installation • Operation • Maintenance

Common Frame  
Motor Generator Set  
Brushless Generator-  
Induction Motor

***Nidec***

**KATO ENGINEERING™**

---

Kato Engineering • P.O. Box 8447 • Mankato, MN USA 56002-8447 • Tel: 507-625-4011  
Fax: 507-345-2798 • Email: [KatoEngineering@mail.nidec.com](mailto:KatoEngineering@mail.nidec.com) • [www.kato-eng.com](http://www.kato-eng.com)

Copyright © 2015 Kato Engineering, Inc. All rights reserved

## TABLE OF CONTENTS

### SECTION 1 INTRODUCTION & DESCRIPTION

	Paragraph	Page
INTRODUCTION . . . . .	1.1	1
GENERAL DESCRIPTION . . . . .	1.2	1
CONSTRUCTION . . . . .	1.3	1
METERS AND CONTROLS . . . . .	1.4	3

### SECTION 2 INSTALLATION

RECEIVING INSPECTION . . . . .	2.1	5
UNPACKING AND STORAGE . . . . .	2.2	5
LOCATION . . . . .	2.3	5
MOUNTING MOTOR-GENERATOR . . . . .	2.4	6
ELECTRICAL CONNECTIONS . . . . .	2.5	6
PROTECTIVE DEVICES . . . . .	2.6	6

### SECTION 3 OPERATION

PRE-OPERATION EQUIPMENT CHECK . . . . .	3.1	7
INITIAL START PROCEDURES FOR GENERATORS WITH BOTH MANUAL AND AUTOMATIC VOLTAGE CONTROL . . . . .	3.2	7
INITIAL START PROCEDURES FOR GENERATOR SETS WITH MANUAL VOLTAGE CONTROL . . . . .	3.3	8
INITIAL START PROCEDURES FOR GENERATOR SETS WITH AUTOMATIC VOLTAGE CONTROL . . . . .	3.4	8
SINGLE GENERATING OPERATING INSTRUCTIONS . . . . .	3.5	9
OPERATION OF STANDBY GENERATOR . . . . .	3.6	9
OPERATING INSTRUCTIONS FOR PARALLEL OPERATION OF GENERATORS . . . . .	3.7	9
PHASE ROTATION . . . . .	3.8	9
SYNCHRONIZING PARALLELED GENERATORS . . . . .	3.9	9
DIVISION OF POWER LOAD AMONG PARALLELED GENERATORS . . . . .	3.10	10
DIVISION OF REACTIVE KVA AMONG PARALLELED GENERATORS . . . . .	3.11	10

### SECTION 4 MAINTENANCE

PREVENTIVE MAINTENANCE . . . . .	4.1	11
CLEANING . . . . .	4.2	11
WINDINGS – PROTECTION . . . . .	4.3	11
INSULATION RESISTANCE TEST . . . . .	4.4	11
DRYING WINDINGS . . . . .	4.5	12
STATOR WINDING SHORT CIRCUIT TEST . . . . .	4.6	12
TESTING BRUSHLESS EXCITER ROTATING RECTIFIERS DIODES WITH AN OHMMETER . . . . .	4.7	12
TESTING BRUSHLESS EXCITER ROTATING RECTIFIERS WITH A TEST LAMP . . . . .	4.8	12
TESTING SURGE PROTECTOR WITH TEST LAMP . . . . .	4.9	13
EXCITER ARMATURE AND ROTATING RECTIFIER ASSEMBLY REMOVAL . . . . .	4.10	13
EXCITER ARMATURE AND ROTATING RECTIFIER ASSEMBLY INSTALLATION . . . . .	4.11	14
REMOVING AND REPLACING EXCITER STATOR ASSEMBLY . . . . .	4.12	14
RESTORING RESIDUAL MAGNETISM . . . . .	4.13	15
BEARING LUBRICATION . . . . .	4.14	15
REMOVING BEARINGS . . . . .	4.15	15
INSTALLING BEARINGS . . . . .	4.16	16
TROUBLESHOOTING . . . . .	4.17	16
ASSEMBLY AND DISASSEMBLY OF KATO COMMON FRAME MOTOR – GENERATOR WITH COOLING FANS MOUNTED OUTBOARD OF THE MOTOR ROTOR . . . . .	4.18	20
ASSEMBLY AND DISASSEMBLY OF KATO COMMON FRAME MOTOR – GENERATOR WITH UNIDIRECTIONAL COOLING FAN LOCATED BETWEEN MOTOR AND GENERATOR ROTOR . . . . .	4.19	22
RENEWAL PARTS ORDERING INFORMATION . . . . .	4.20	22
WARRANTY . . . . .		23

# SECTION 1 INTRODUCTION & DESCRIPTION

## 1.1 INTRODUCTION

1.1.1 This manual contains instructions for installing, operating and maintaining KATO Motor -Generator Sets which consist of a Brushless Revolving Field Generator and an Induction motor contained in a common frame. This manual also describes the basic construction and the principles of operation of this series of generators.

1.1.2 Electrical connection drawings, part drawings and part listings for the specific model, type and serial number motor - generator are usually contained as supplementary information in a separate excerpt of the motor - generator manual. These drawings are the official source of information for making electrical connections or ordering replacement parts.

## 1.2 GENERAL DESCRIPTION

1.2.1 The Motor -Generators described in this manual are of the Common Frame type. Motor and generator rotors are stacked on a common shaft and the motor and generator stators are contained in a single frame eliminating the problems encountered in aligning separate motor - generators.

1.2.2 The motor - generators may be supplied with various custom engineered controls designed to provide the users exact power needs. Controls may be contained in separate wall mounted cubicles, in free standing control cubicles or in a control box mounted to the motor - generator frame depending upon the number and size of the controls required or the customers specifications.

1.2.3 All controls used on KATO Generator Sets are those which have proved during many years of service to be the most reliable. Should replacement of a control device be necessary, a complete line of replacement controls can be supplied by Kato Engineering Company in a very minimum of "waiting" time. When generators are used as vital power units it is recommended that a spare of control devices such as voltage regulators be kept on hand at all times. Should a failure of these vital devices occur, install the spare and return the defective assembly to Kato Engineering Company for repair.

1.2.4 This manual contains information of the motor, the generator and the direct connected brushless exciter. A complete description of control devices such as voltage regulators will be contained in the manual supplied by the manufacturer of the control.

## 1.3 CONSTRUCTION

1.3.1 KATO Motor -Generator Sets are custom engineered by an expert power engineering staff to provide your exact power needs. All machines are carefully designed and constructed to ensure trouble free operation and maximum service life. The sturdy common frame is fabricated of heavy steel members welded to the endbell pilot rings. A heavy steel base is welded to the frame assembly to simplify installation of the motor -generator. Eyebolts installed in the frame enable the complete motor -generator to be lifted with a conventional overhead hoist. A heavy steel wrapper cover of drip-proof construction encloses the frame assembly.

1.3.2 The stationary generator and motor cores are contained in the common frame. The generator stator core is constructed of one-piece steel laminations. The steel laminations are assembled under pressure to form the stator core. The assembled core is rigidly welded to the frame ribs and heavily insulated stator coils of highest quality magnetic copper are then inserted in the stator slots. Stator core slots are insulated with highest quality insulating material. The motor stator construction is essentially the same as the generator stator described above. The complete assembly is completely impregnated with electrical varnish and baked several times to ensure excellent bonding qualities, high dielectric strength and maximum moisture resistance. The complete assembly is then coated with a fungus proof varnish. Stator leads on most units are brought out to a convenient junction box located on the generator frame. The leads terminate in standard connection lugs or strap copper terminals for ease of connection to the load lines.

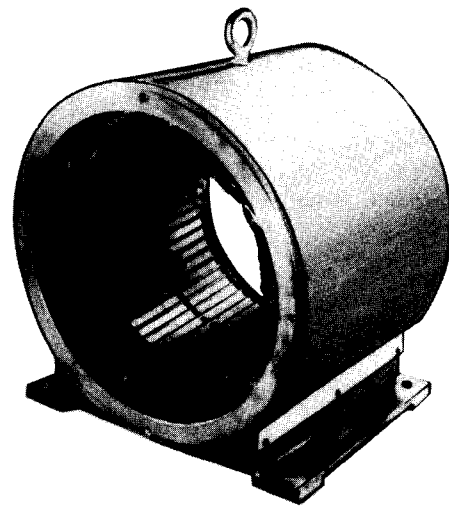

Figure 1-1 Motor -Generator Frame Stator Assembly

1.3.3 Both the induction motor squirrel cage rotor and the generator rotating field poles are mounted on a common large diameter shaft. An extension of the shaft provides mounting for the sleeve type direct connected brushless exciter.

1.3.4 The generator field poles on most models are made of carefully selected one piece electrical steel laminations which are assembled under pressure. Thus, the anchoring problem is eliminated, and a continuous magnetic path is provided. Field coils of heavily insulated wire are machine wound directly onto poles with insulating varnish or the new "extra strength" epoxies between each layer. Coils are blocked and braced for physical strength and rigidity. Damper windings of heavy copper bars imbedded in poles and rigidly brazed to end rings are standard on KATO revolving field generators keeping damping current losses low and limiting increase of third harmonic voltage with increase of load. The damper windings also prevent "hunting" during parallel operation of generators. The entire rotor is dipped and baked to form one complete, homogeneous mass. Field poles of larger slower speed 50 and 60 cycle models are of salient pole construction. The poles and spider are dovetailed to withstand maximum centrifugal forces. The assembled poles are securely wedged in the dovetailed spider and held in place with the large pole retaining bolts and steel wedges.

1.3.5 The induction motor rotor is of the squirrel cage type. The rotor core is pressed on the common shaft. The rotor windings consist of imbedded conducting bars which are short circuited by attaching the bars to end rings.

1.3.6 The brushless exciter is used to provide the excitation current to the rotating field assembly of synchronous generators of brushless design. The brushless exciter is in effect, a refinement of the conventional direct connected exciters which use brushes and commutators. The extensive brush rigging and sliding contacts are eliminated on the brushless assembly thus, parts subject to wear are eliminated and prolonged period of dependable, trouble free operation is assured. The exciter consists of two basic component assemblies; the exciter stationary field assembly and the exciter rotating armature and rotating rectifier bridge assembly.

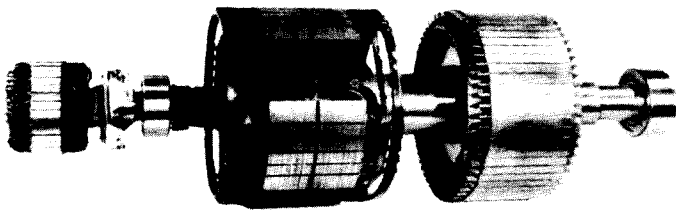

Figure 1-2 Motor-Generator Rotor, Brushless Exciter Armature Assembly

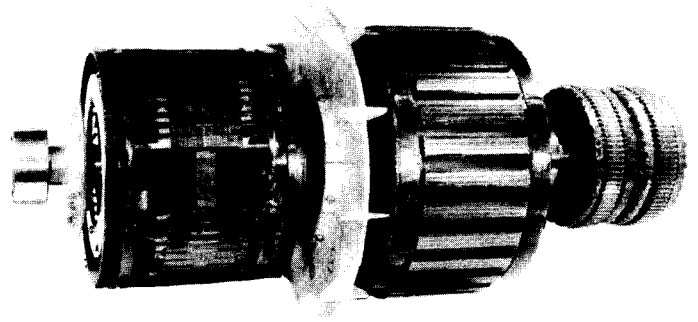

Figure 1-3 Motor-Generator Rotor, Brushless Exciter Armature Assembly with a Center Mounted Fan

1.3.7 The exciter armature and rotating rectifier bridge assembly is sleeve mounted on the rotor shaft at the generator end of the motor-generator assembly. The exciter armature core consists of a stack of steel laminations assembled under pressure. Three phase exciter armature windings are wound on the exciter armature core. The rotating rectifier assembly on most models consists of a full wave rectifier bridge made up of six semiconductor devices mounted on aluminum heat sinks. Diodes on current models are retained in the heat sink assemblies with retaining nuts and washers. Thus, should a failure of a diode occur, the defective diode can be easily replaced in the heat sink. Heavy insulating rings separate the negative and positive components of the full wave rectifier bridge.

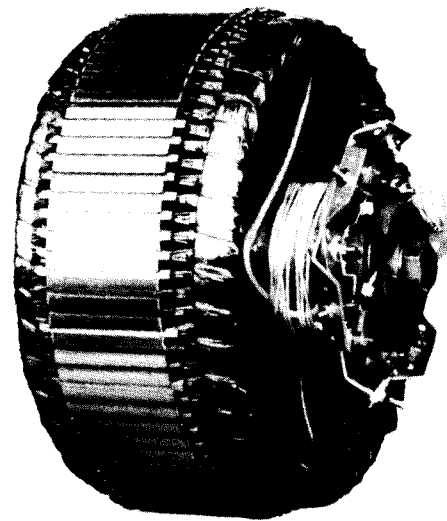

Figure 1-4 Brushless Exciter Armature and Rotating Rectifier Assembly.

1.3.8 The exciter stator on most models are high frequency assemblies consisting of a core made up of punched steel laminations and field coils wound in the core slots. The steel laminations are assembled under pressure and the core assembly is then welded to the exciter frame. Following installation of the core in the exciter frame the coil windings are wound in the insulated semi-closed core slots. A heavy removable sheet metal cover protects the entire assembly.

1.3.9 During operation of brushless revolving field generators, the three-phase power generated in the exciter armature is applied directly to the rotating rectifier assembly. The forward polarity diodes mounted on one heat sink and the reverse polarity diodes on the other heat sink are connected to form a three-phase, full wave rectifier bridge. The rotating rectifier bridge assembly rectifies the alternating current supplied by the exciter armature. The direct current output of the rotating rectifier bridge assembly is in turn, applied to the rotating field of the generator via lead wires routed through a key-way shaped slot on the rotor shaft. Thus, the exciter armature, rotating rectifier bridge and the generator field form a single rotating assembly which eliminates the need of the sliding contacts associated with conventional DC exciters.

1.3.10 Excitation current for the stationary field coils is supplied by the synchronous generator through the stationary rectifier bridge or through an automatic voltage regulator. A voltage adjust rheostat is provided which permits, by adjustment of the rheostat, selection of the output voltage at any voltage of from approximately 90 percent to approximately 110 percent of the rated value of the generator. The most common types of automatic voltage regulators used on KATO Synchronous Brushless Generators are solid state devices which obtain their power from the generator output. This type of regulator continuously compares the output voltage of the generator with a stable reference voltage. The difference between these two voltage constitutes an error signal that is higher or lower than the reference voltage.

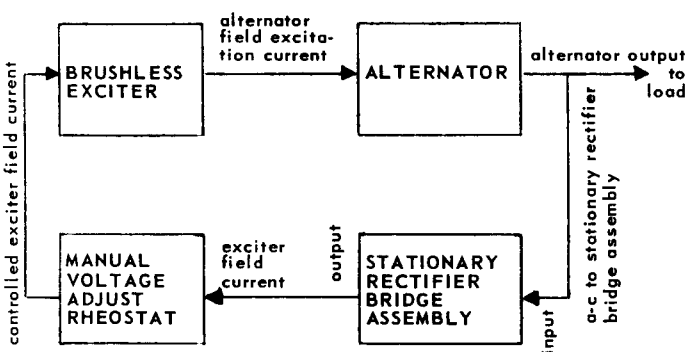

Figure 1-5 Block Diagram, Typical Brushless Generator Utilizing a Stationary Rectifier Bridge to Supply Exciter Field Current

This error signal is amplified and used to control the direct current output of the voltage regulator which is applied to the exciter field. The amplifier keeps the difference voltage between the generator and the reference voltage very small, therefore, giving close regulation of the generator output voltage.

1.3.11 Bearing housings on most Kato Generator Sets over 75 KW in size with an 18 inch diameter or larger stator have grease fittings installed to permit periodic replenishment of grease. Bearing and bearing housings are constructed as illustrated in figure 1-7. A lubrication plate attached to the generator set lists recommended lubrication intervals and amount of grease to be added at each interval.

1.3.12 Bearings on most Kato Generator Sets under 75 KW in size with a 14 inch diameter or smaller stator, are of the fully shielded type, illustrated in figure 1-6. These bearings do not require periodic replenishment of grease. Repacking at major overhaul of the generator or prime mover is generally a good preventive maintenance practice. Additional information is contained in paragraph 4.14.2, page 15.

1.3.13 KATO Common Frame Motor - Generator Sets are designed with a self contained cooling system which circulates coolant air through the machine. Ambient air is drawn into the machine through louvered openings at the exciter end of the machine by a large capacity blower. The warm air is exhausted to atmosphere through the screened opening enclosing the blower assembly.

## 1.4 METERS AND CONTROLS

1.4.1 A complete line of meters and controls are available for all KATO generators and motor-generator sets. Standard equipment for KATO Brushless Motor-Generator Sets and a brief description of some of the optional equipment available for these machines are contained in paragraphs 1.4.2 through 1.4.4.

1.4.2 Optional Generator Controls consist of automatic voltage regulators for automatic regulation of the generator output voltage, manual exciter field application devices for manual control of the generator output, load circuit breakers or output contactors, overload, overvoltage and under voltage devices, field adjust rheostats, voltage-droop or cross-current compensation circuits, meters and meter line selector switches to name but a few.

1.4.3 Optional exciter field application devices for manual regulation of the generator output consists of a stationary rectifier bridge assembly and a manual voltage adjust rheostat. The incoming power source for the stationary rectifier bridge assembly is taken from the generator output. Exciter field current is controlled by adjusting the manual voltage adjust rheostat. The rheostat is normally sized so that the field current can be adjusted as desired to provide a selected output voltage of from 90 to 110 percent of the

nominal voltage rating of the generator. The stationary rectifier bridge will provide inherent regulation of the generator. When the generator output must be closely regulated, an automatic voltage regulator should be used. A block diagram of a brushless generator with a stationary rectifier bridge used to supply exciter field current is shown in Figure 1-5.

1.4.4 Solid state voltage regulators which provide maximum voltage regulation under various load conditions are available for most generators. Adjustment of output voltage of from 90 to 110 percent of the nominal voltage rating of the generator is usually accomplished by installation of an

auto-voltage adjust rheostat in the regulated exciter field circuit. When automatic voltage regulators are installed the stationary rectifier bridge and manual voltage adjust rheostat may be eliminated or the stationary rectifier bridge can be used as a secondary source for supplying the exciter field current. When controls such as voltage regulators are incorporated, a complete description of the control as well as its operation can be obtained by referring to the instructions supplied by the manufacturer of the control.

1.4.5 Some of the optional motor controls are circuit breakers, line switches, magnetically operated start contactors, start-stop switches and overload relay assemblies.

AVY DUTY DOUBLE SHIELDED BALL BEARINGS  
shields keep grease in - dirt and moisture out; factory lubricated and normally will not require replenishment of grease during life of bearing

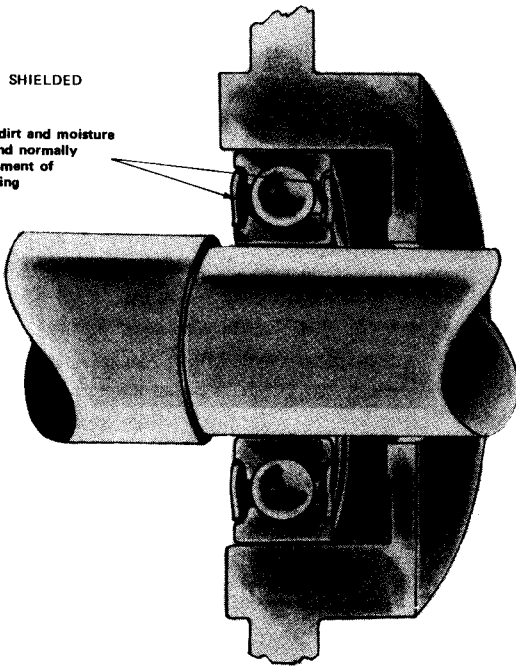

FIGURE 1-6 TYPICAL SEALED BEARINGS AND BEARING HOUSING CONSTRUCTION

GREASE FITTING installed at factory  
GREASE RESERVOIR holds large reserve of grease  
BEARING SHIELD keeps grease in; dirt and moisture out  
GREASE RELIEF along the shaft automatically eliminates excessive grease due to heat expansion or careless overgreasing  
RELIEF VALVE additional relief of excess grease; protects bearing seal from high grease gun pressure

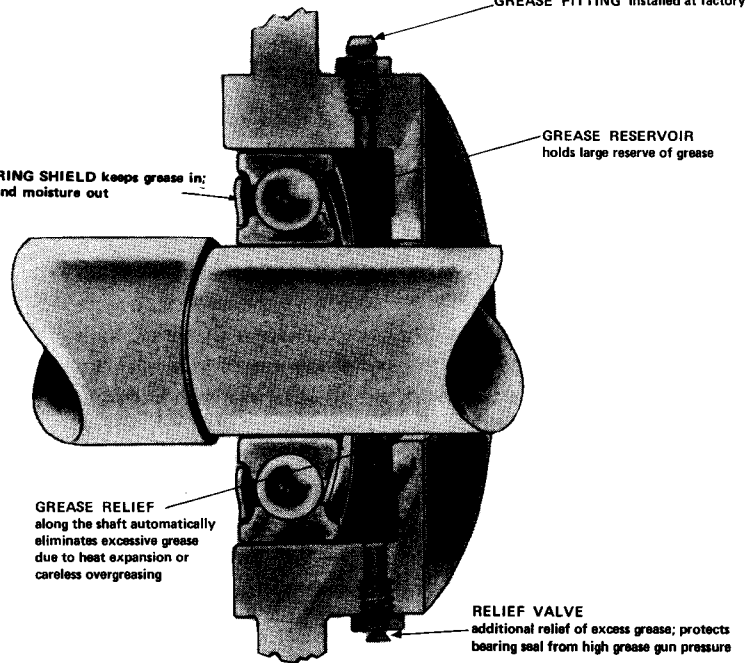

FIGURE 1-7 TYPICAL REGREASABLE BEARING AND BEARING HOUSING CONSTRUCTION

# SECTION 2 INSTALLATION

## 2.1 RECEIVING INSPECTION

2.1.1 The KATO Motor-generator Set is carefully packed and crated for shipment, and can withstand most shocks incurred during transit. Before accepting shipment from the transportation company examine the crating carefully to determine if any damage has occurred during shipment. Unpack the unit as described in paragraph 2.2 and then carefully examine the sheet metal frame and exciter cover for signs of damage. Remove the exciter cover and examine the inside of the generator for signs of damage. Remove the exciter cover and examine the inside of the generator for signs of damage to windings, lead wires and other internal parts. Inspect for loosely mounted components and the presence of moisture. Inspect to make certain foreign material such as crating nails, loose bolts or packing material which may have fallen into the machine during unpacking are removed. Check clearance of rotating and stationary parts. Turn rotor to make certain it turns freely without binding. If damage is noted, determine the extent of damage and immediately notify the transportation company claims office and KATO Engineering Company. Be sure to give complete and accurate details when reporting damage.

2.1.2 If the generator is to be placed in storage repackage and crate the generator set. Recommended procedures for storage are contained in paragraph 2.2.

## 2.2 UNPACKING AND STORAGE

2.2.1 If the generator is received during cold weather, let the crated unit stabilize to room temperature before removing the protective crating and packing material. This precaution will minimize the condensation of moisture on coil surfaces, eliminating the possibilities of wet windings and insulating materials which could cause early malfunctions of the generator.

2.2.2 Unpack the generator with care to avoid damage to the unit. Move the generator to the mounting location either by attaching an overhead hoist to the eye-bolts installed in the generator frame or by lifting the generator from underneath the base with a fork lift. Determine that the hoist, when used, is of sufficient strength to adequately support the weight of the motor-generator. When moving units with a fork lift make certain it is completely onto and balanced on the fork lift tines. Make certain fork lift tines do not apply pressure to the motor-generator sheet metal wrapper cover.

## CAUTION

**Always make certain extreme care is taken when moving the generator to prevent its striking other objects or personnel. Never apply a lifting force to structural points other than those provided for that purpose.**

2.2.3 If the generator is not to be installed in its operating location as soon as received, it should be stored in a clean dry area, not subject to sudden temperature or humidity changes. If possible, storage should be in an ambient temperature of approximately normal room temperature. Units which cannot be stored in a temperature and humidity controlled area and which are to be in storage for periods of longer than six months, should be prepared for storage by installing desiccant bags in the exciter cover and inside the fan screen and vacuum sealing the unit in a covering of plastic or other material designed for that purpose. The unit should be adequately tagged to ensure that desiccant bags are removed before the unit is placed in operation.

## 2.3 LOCATION

2.3.1 The KATO motor-generator can be installed in any clean, dry, well ventilated area which affords sufficient accessibility for operation and maintenance of the unit and which allows a sufficient unobstructed flow of coolant air. Avoid locations which would subject the generator to excessive moisture, dust, steam or the fumes from acids, alkalines or other corrosive chemicals. If such exposure cannot be avoided, establish a rigid periodic maintenance schedule. The adverse effect of excessive moisture can usually be eliminated or at least greatly lessened by the use of space or strip heaters.

2.3.2 The installation of control cubicals is usually not critical. Wall mounted control cubicles can be mounted on any wall or steel bulkhead which will adequately support the weight of the control cubicle. The control cubicle and generator frame must be grounded to a common ground. Interconnecting lines between the generator and the control cubicle as well as all incoming and load lines must be to National Electrical Code and local electrical codes.

2.3.3 The foundation or supports which mount the generator and prime mover must be rigid, level and of ample size and strength to support the weight of the motor-generator set. Although a reinforced concrete foundation usually makes the best foundation for heavy machinery, the motor-generator set may be placed on any concrete, steel or other structural material which will adequately support the weight of the unit. Bearing loads of structural materials can be obtained by referring to engineering handbooks.

## 2.4 MOUNTING MOTOR - GENERATOR

2.4.1 If the foundation is slightly uneven, install shims under the Motor - Generator mounting pads until all pads are in contact with the foundation. Use a feeler gage to determine thickness of shims required.

2.4.2 When generator sets are installed in areas such as office buildings where noise or vibration would be a nuisance, these undesirable effects can usually be eliminated or greatly reduced by installing vibration dampeners. KATO base mounting feet when properly installed provide a means of easily leveling generator sets as well as providing "vibration dampening". Install KATO base mounting feet as shown on figure 2-1

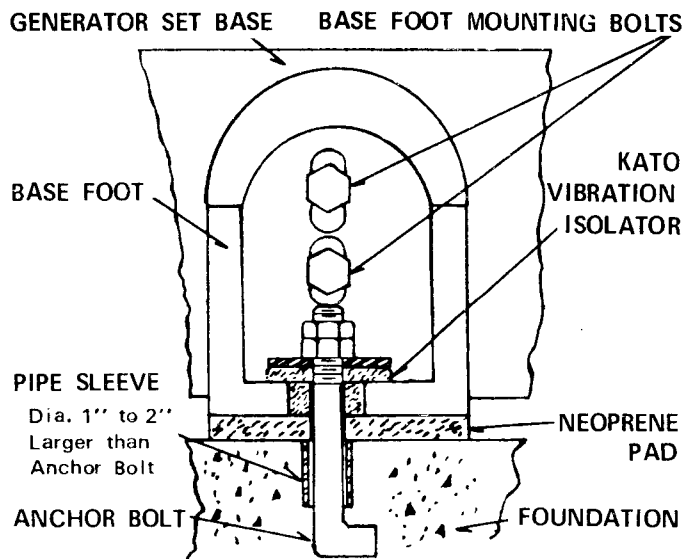

Figure 2-1 Leveling and Mounting Motor-Generator Sets which incorporate Kato Base Feet.

## 2.5 ELECTRICAL CONNECTIONS

2.5.1 Before connecting the motor - generator to the electrical power load, check nameplate for the electrical characteristics and connect the unit exactly as shown in the connection diagrams. Refer to National Electrical Code or applicable local regulations for minimum specifications for wire size, conduit and protective devices.

2.5.2 Contact KATO Engineering Company before attempting to make any changes in control component interwiring.

## 2.6 PROTECTIVE DEVICES

2.6.1 Refer to National Electrical Code and local electrical codes for minimum requirements.

Level unit by loosening base foot mounting bolts and then sliding base foot in elongated slots.

Anchor the assembly to foundation with anchor bolts. Use KATO vibration isolators to provide vibration isolation.

Do not secure anchor bolt nuts too tightly. Compression of vibration isolator and neoprene pad will eliminate their effectiveness in dampening vibration.

# SECTION 3 OPERATION

## 3.1 PRE-OPERATION EQUIPMENT CHECK

3.1.1 After the motor - generator and control equipment is completely installed and wired, but before operating the unit for the first time, perform a check of the equipment as follows:

- a. If the generator has been subjected to extreme dampness during shipment or storage it may be necessary to dry out windings before placing the unit in operation. Refer to the procedures for testing winding insulation resistance and the procedures for drying windings described in section 4 of this manual. Generators being placed in operation after being subjected to very low temperatures should be slowly warmed to prevent condensation.
- b. Check all interconnecting wiring against the connection diagrams supplied with the generator set.
- c. Make certain no foreign objects are lodged in the generator. Remove all tools and shop cloth from the vicinity of the equipment.
- d. Make certain all covers and guards are installed.

## 3.2 INITIAL START PROCEDURES FOR GENERATORS WITH BOTH MANUAL AND AUTOMATIC VOLTAGE CONTROL

3.2.1 This procedure describes general instructions for operation of generator sets incorporating both stationary rectifier bridge assemblies and automatic voltage regulators to supply exciter field current.

3.2.2 After installation is complete and the checks listed in paragraph 3.1.1 have been completed make an initial start and operational checkout of the equipment as listed in the following general instructions:

- a. Open the **Output Circuit Breaker** to disconnect the generator from the load.
- b. Turn **Voltage Adjust Rheostats** to full counterclockwise position.
- c. Actuate **Auto-Manual Switch** to the **Manual** position.
- d. Start motor - generator set. When unit reaches normal speed stop motor - generator set. Check rotation as unit slows to stop. If rotation is not cor-

rect reverse motor incoming power leads. On three phase motors, reverse any two incoming lines (except when used, the neutral line).

- e. Start and stop generator set several times. Observe any unusual conditions such as excessive noise or vibration. Allow sufficient time between starts for cooling.
- f. When operation is satisfactory to this point, turn **Voltage Adjust Rheostat** to approximately the midpoint position. Make certain only **Manual Adjust Rheostat** is adjusted at this point in the operational test.
- g. Close **Output Circuit Breaker** and apply a light load. Adjust **Manual Voltage Adjust Rheostat** until generator produces desired output voltage. Slowly increase load to generator rated power factor full load value. Adjust **Manual Adjust Rheostat** as necessary to obtain desired output voltage.
- h. Reduce load to minimum and actuate **Auto-Manual Switch** to **Auto** position.
- i. Adjust **Auto Voltage Adjust Rheostat** to obtain desired output voltage.
- j. Check voltage regulation by applying the rated power factor load, and then checking the generator terminal voltage. Check voltage regulation. Refer to regulator manufacturers operating instructions.
- k. During operation, observe the generator at regular intervals so that any abnormal conditions can be corrected before serious damage occurs.
- l. Check current on each line. Use a clip-on ammeter if an ammeter is not incorporated in generator set.
- m. Check line to line and line to neutral voltages.
- n. When operational checks are satisfactory, stop motor - generator set.

### 3.3 INITIAL START PROCEDURES FOR GENERATOR SETS WITH MANUAL VOLTAGE CONTROL

3.3.1 This procedure describes general instructions for operation of generator sets incorporating a stationary rectifier bridge assembly to supply exciter field current.

3.3.2 After installation is complete and the checks listed in paragraph 3.1.1 have been completed make an initial start and operational checkout of the equipment as listed in the following general instructions:

- a. Open the **Output Circuit Breaker** to disconnect the generator from the load.
- b. Turn **Manual Voltage Adjust Rheostat** to full counter-clockwise position.
- c. Start the generator set. When motor - generator reaches normal speed stop motor - generator set. Check rotation as unit slows to stop. If rotation is not correct reverse motor incoming power leads. On three phase motors, reverse any two incoming lines (except when used, the neutral line).
- d. Start and stop generator set several times. Observe any unusual conditions such as excessive noise or vibration. Allow sufficient time between starts for cooling.
- e. When operation is satisfactory to this point, turn **Manual Voltage Adjust Rheostat** to approximately the midpoint position.
- f. Close **Output Circuit Breaker** and apply a light load. Adjust **Manual Voltage Adjust Rheostat** until desired output voltage is obtained. Slowly increase load to the generator full load rated power factor value. Adjust **Manual Voltage Adjust Rheostat**, as necessary, to obtain desired output voltage.
- g. During operation, observe the generator at regular intervals so that any abnormal conditions can be corrected before serious damage occurs.
- h. With a steady rated power factor full load applied, check current on each line. Use a clip-on ammeter if an ammeter is not incorporated in generator set.
- i. Check line to line and line to neutral voltages.
- j. When operational checks are satisfactory, stop motor - generator set.

### 3.4 INITIAL START PROCEDURES FOR GENERATORS WITH AUTOMATIC VOLTAGE CONTROL

3.4.1 This procedure describes general instructions for operation of generator sets which use automatic voltage regulators to supply and control the exciter field current. The voltage regulator provides automatic regulation of the generator output voltage.

3.4.2 After installation is complete and the checks listed in paragraph 3.1.1 have been completed make an initial start and operational checkout of the equipment as listed in the following general instructions:

- a. Open the **Output Circuit Breaker** to disconnect the generator from the load.
- b. Turn **Auto-Voltage Adjust Rheostat** to full counter-clockwise position.
- c. Start the generator set. When motor - generator reaches normal speed stop motor - generator set. Check rotation as unit slows to stop. If rotation is not correct reverse motor incoming power leads. On three phase motors, reverse any two incoming lines (except when used, the neutral line).
- d. Start and stop generator set several times. Observe any unusual conditions such as excessive noise or vibration. Allow sufficient time between starts for cooling.
- e. When operation is satisfactory to this point, turn **Auto-Voltage Adjust Rheostat** to approximately the midpoint position.
- f. Close **Output Circuit Breaker** and apply a light load. Adjust **Auto-Voltage Adjust Rheostat** until desired output voltage is obtained. Slowly increase load to the generator rated power factor full load value. Adjust **Auto-Voltage Adjust Rheostat**, as necessary, to obtain desired output voltage.
- g. Check voltage regulation.
- h. During operation, observe the generator at regular intervals so that any abnormal conditions can be corrected before serious damage occurs.
- i. With a steady rated power factor full load applied, check current on each line. Use a clip-on ammeter if a ammeter is not incorporated in generator set.
- j. Check line to line and line to neutral voltages.
- k. When operational checks are satisfactory, stop motor - generator set.

### 3.5 SINGLE GENERATING OPERATING INSTRUCTIONS

3.5.1 Start and operate the generator set in accordance with the following general instructions:

- a. When **Voltage Adjust Rheostats** have been previously adjusted to provide the desired output voltage, no adjustment of the rheostats should be required before placing the generator set in operation. If previous voltage setting is not known, adjust to midpoint position before placing set in operation. Adjust to obtain desired voltage during operation.
- b. When an **Auto-Manual Switch** is incorporated, normal operation should be with the switch in the **Auto** position. Operate the generator with the switch in the **Manual** position only to checkout equipment or as an emergency in the event of voltage regulator failure.

#### CAUTION

**Do not actuate Auto-Manual Switch with full load applied to the generator.**

- c. Start the motor - generator set.
- d. Check voltage regulation with rated power factor load applied.
- e. During operation, observe the generator at regular intervals so that any abnormal conditions can be discovered and corrected.
- f. Stop the motor - generator set.
- g. When the generator set is operated as a standby unit open the **Output Circuit Breaker** following shutdown of the generator set.

### 3.6 OPERATION OF STANDBY GENERATOR

3.6.1 Make certain **Output Circuit Breaker** of the primary power source is open before starting the **Standby Unit**. Operate the generator set as described in paragraph 3.5.1. Following shutdown of the **Standby Unit** make certain **Output Circuit Breaker** is actuated to the **Open** position.

### 3.7 OPERATING INSTRUCTIONS FOR PARALLEL OPERATION OF GENERATORS

3.7.1 When operating two or more generators connected in parallel, open output circuit breaker and start each generator as described in steps (a) through (d) of para-

graph 3.5.1. Make certain that the output voltage of each machine is properly adjusted to the system bus voltage.

**NOTE:** Do not attempt to parallel generators when the generator controls are not designed for parallel operation. Before attempting to parallel generators ascertain if generator controls are designed for parallel operating by contacting KATO Engineering Company Engineering Dept.

#### CAUTION

**Do not close the load circuit breakers until the generators have been checked for proper phase rotation and adjusted for synchronization as detailed in the following paragraphs.**

### 3.8 Phase Rotation

3.8.1 Before placing two or more three-phase generators in parallel, make certain the generators have the same phase rotation. This can be accomplished by connecting a three phase induction motor to each of the generators and checking the rotation of the motor. Care must be taken to make certain motor terminals are connected to the corresponding generator or bus terminals for each test. Phase rotation will be the same if the motor rotates in the same direction when connected to each generator.

3.8.2 If the motor rotates in the wrong direction when connected to one of the generators, reverse any two of the three generator leads (except neutral when used). Recheck motor rotation and continue checks until the induction motor rotates in the correct direction.

### 3.9 Synchronizing Paralleled Generators

3.9.1 Do not attempt to parallel generators until each machine to be paralleled has been checked for proper phase rotation and that each generator is adjusted for the required system voltage with the line switch open.

3.9.2 If a synchroscope is not available, generators can be synchronized by using incandescent lamps connected in the load circuit as shown in figure 3-1. Make certain that the total voltage rating of the series lamps equals the voltage rating of the generator.

3.9.3 Synchronize the generators by varying the speed of the incoming generator until fluctuation of the lamps is very slow. When the lamps are dark close the line switch. Care must be taken to close the line switch at the instant the lamps are dark.

#### WARNING

**Exercise extreme caution when using this method of synchronizing generators to avoid exposure to dangerous voltages.**

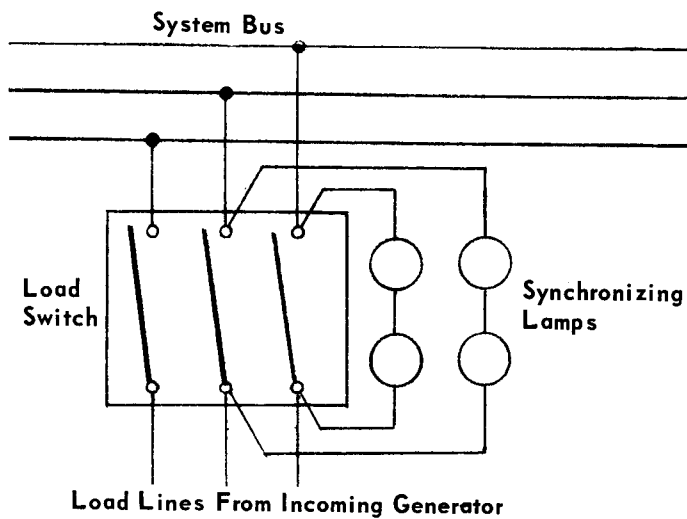

**Figure 3-1 Synchronizing Paralleled Generators With Test Lamps**

### 3.10 Division of Power Load Among Paralleled Generators

3.10.1 Division of kilowatt or actual power load among generators operating in parallel is practically independent of generator excitation. Do not attempt to vary the amount of kilowatt load among paralleled generators by making adjustments to the voltage regulator.

### 3.11 Division of Reactive KVA Among Paralleled Generators

3.11.1 Division of reactive KVA among paralleled generators depends upon generator excitation. Methods of correcting the excitation of individual generators should they take more or less than their share of the reactive KVA are the addition of cross-current compensation or voltage-droop controls to the voltage regulator circuit.

3.11.2 Adjustment of the cross-current or voltage droop rheostat would usually be set so that there is just enough resistance in the circuit to give stable operation of the generators under reactive KVA load conditions.

3.11.3 Place generator in operation apply lagging power factor load and check voltage droop. Maximum voltage droop from no load to full load is obtained with full voltage-droop resistance. A droop of 4% is frequently employed. Adjust each generator to be paralleled for identical droop characteristics.

3.11.4 Bring all generators up to correct speed and adjust all output voltage to identical values. Synchronize and parallel generators. Load the paralleled generators and check for satisfactory division of load currents. Correct by adjusting voltage-adjust rheostats and the droop-control resistors.

# SECTION 4 MAINTENANCE

## 4.1 PREVENTIVE MAINTENANCE

4.1.1 Preventive maintenance is the practice of inspecting the generator set, cleaning the generator set and eliminating minor disorders before they become serious. A routine regular preventive maintenance program practiced conscientiously will ensure peak performance, lengthen the life of the generator, and eliminate or at least greatly reduce breakdown time.

4.1.2 The quarterly preventive maintenance schedule described in TABLE A is enclosed as a guide for establishing a preventive maintenance program for generators operating under standard conditions. The specific operating conditions should be analyzed by the user of the equipment and a preventive maintenance program established accordingly. When preventive maintenance inspection determines cleaning is necessary, clean the generator & controls as described in paragraph 4.2.1.

## 4.2 CLEANING

4.2.1 When inspection determines cleaning is necessary clean the motor-generator and controls as follows:

a. Wipe loose dirt from exterior painted surfaces of motor-generator and when incorporated the motor-generator controls panel assembly (controller) with a clean cloth. Remove stubborn accumulations of dirt with detergent or solvent. Clean all ventilating ports with a vacuum cleaner or filtered compressed air at a pressure of from 25 to 40 psi.

### WARNING

Observe precautions specified by the manufacturer of the solvent.

b. Clean inside of motor-generator with a vacuum cleaner or use dry filtered compressed air at a pressure of from 25 to 40 psi. Remove stubborn accumulations of dirt and grease from windings with naphtha.

### WARNING

Exercise extreme care when using naphtha. Use only in well ventilated flame and spark free area.

c. Clean electrical contacts such as relay contacts, switch contacts and terminals with an approved contact cleaner. **Do not file contacts.**

**TABLE A**  
Quarterly Preventive Maintenance Schedule

1. Inspect lead wires and control devices wiring for cracked insulation and loose terminals.
2. Inspect control equipment for loose mounting hardware.
3. Inspect control devices for accumulation of dust, moisture and other foreign matter.
4. Clean the outside of the motor-generator assembly and ventilating screens.
5. When dust or moisture is excessive, clean and/or dry the inside of motor-generator assembly.
6. With unit running check control devices and meters for correct adjustment and operation.
7. With unit running observe any unusual noise or vibration. Refer to trouble-shooting chart for possible causes of noise and vibration
8. Bearing Lubrication: See paragraph 4.14 through 4.14.2, page 15.

## 4.3 WINDINGS – PROTECTION

4.3.1 Generators operating intermittently in very damp locations should be protected with space heaters. Generators being placed in operation after being subjected to very low temperatures should be slowly warmed to prevent excessive condensation. Windings resistance should be checked before placing the generator in operation if the unit was subjected to an extremely damp and/or cold environment for an extended period of time.

## 4.4 INSULATION RESISTANCE TEST

4.4.1 A hand cranked megger of not over 500 volts is a convenient and safe method. An accepted standard for measuring insulation resistance of stator windings at 75 C. measured at 500 volts DC after one minute should not be less than:

$$\text{Resistance in megohms} = \frac{\text{Rated Voltage of Machine} + 1000}{1000}$$

The above formula is satisfactory for most checks. For more information see "Recommended Practice for Insulation Resistance Testing AC Rotating Machinery", AIEE Standard No. 43.

## 4.5 DRYING WINDINGS

4.5.1 If the insulation fails to meet the test standards, the generator may be dried out by heat from a warm air oven, heat lamps or strip heaters. The temperature should not exceed 75° C. (167° F.)

### WARNING

When oven drying, use a forced air circulation oven, not a radiant type. Radiant type oven would overheat some generator parts before remote parts reached a satisfactory temperature.

## 4.6 STATOR WINDING SHORT CIRCUIT TEST

4.6.1 Use an inside-type growler and test each coil in the stator. Position the growler in the stator and hold a thin metal strip, similar to a hacksaw blade, parallel to the core slots. Energize the growler and explore the core surfaces approximately 1 pole distance on each side of the growler. Continue testing 1 core slot at a time until all coils are tested. If the winding is shorted, the metal strip will vibrate when held over the slot containing the faulty coil.

## 4.7 TESTING BRUSHLESS EXCITER ROTATING RECTIFIERS (DIODES) WITH AN OHMMETER

4.7.1 If a failure of the diode is suspected remove the exciter cover & test diodes with an ohmmeter as follows:

- Remove nut and washer holding diode in heat sink and remove diode lead wire then lift diode from heat sink. Refer to figure 4-3, (4-4 when unit incorporates a half wave rectifier.)
- Refer to figure 4-1, then connect ohmmeter leads across diode (rectifier) in one direction. Note meter reading. Reverse leads and note meter reading. The meter should indicate a low resistance (under 1000 ohms) in one direction and a high resistance (1 megohm to infinity) in the other direction.
- If the meter indicates a low resistance in both directions the diode is shorted. A high resistance in both directions indicates an open diode.

### NOTE

Value of resistance is based on 1.5 volt battery in the meter.

- Replace defective diodes with diodes of the same operating characteristics as diodes installed in generator at the factory. Order diodes by part number including the model and type of the exciter as well as the generator serial number.

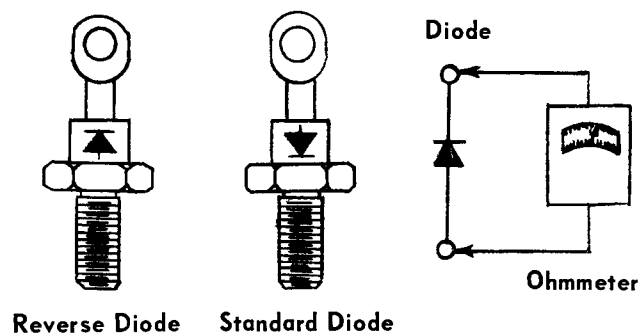

Figure 4-1 Testing Rotating Rectifiers With An Ohmmeter

## 4.8 TESTING BRUSHLESS EXCITER ROTATING RECTIFIERS WITH A TEST LAMP

4.8.1 If an ohmmeter is not available, field rectifiers (diodes) may be tested with a test lamp consisting of standard flashlight batteries and a flashlight bulb as shown in figure 4-2. Refer to figure 4-1 for identification of diode cathode and anode and then test as follows:

- Remove diode as described in step (a) paragraph 4.7.1.
- Connect leads of tester across rectifier (diode) in one direction; then reverse leads. The light should light when the leads are across the diode in one direction and should not light when placed across diodes in the other direction.
- If the light lights in both directions the diode is shorted. If the light does not light in either direction the diode is open.

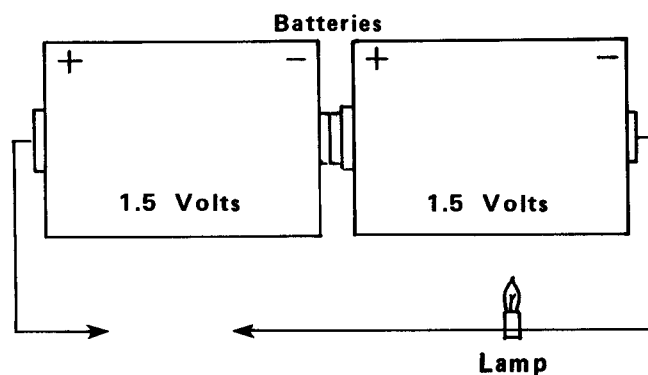
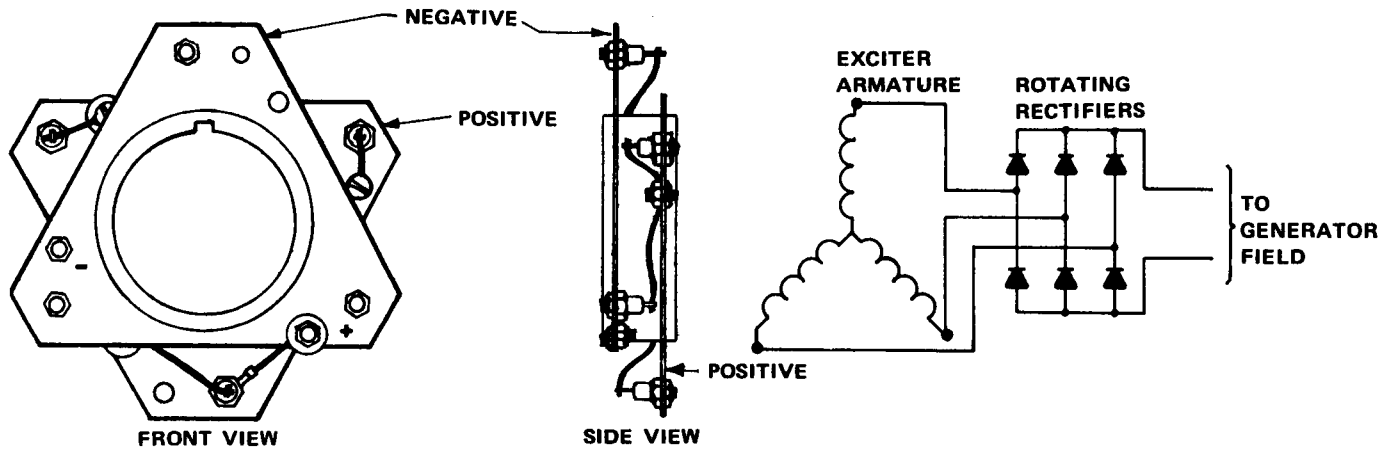

Figure 4-2 Test Lamp



Schematic Illustration, Exciter Armature & Rotating Rectifier

Physical Illustration, Rotating Rectifier Assembly

Figure 4-3 Full Wave Rotating Rectifier And Exciter Armature Assembly

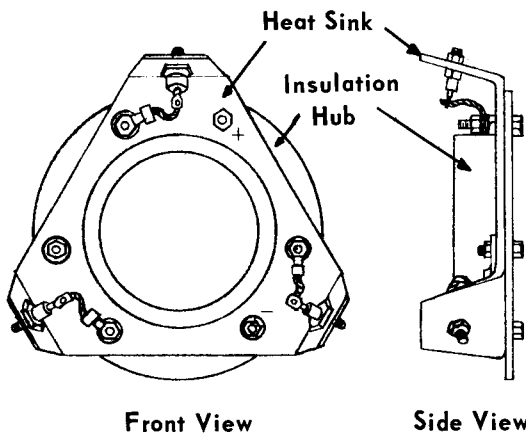

Physical Illustration, Half Wave Rotating Rectifier Assembly

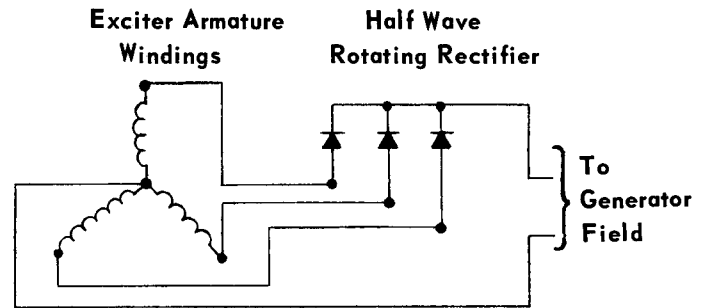

Schematic Illustration, Exciter Armature & Half Wave Rotating Rectifier

Figure 4-4 Exciter Armature & Half Wave Rotating Rectifier Assembly

#### 4.9 TESTING SURGE PROTECTOR WITH TEST LAMP

4.9.1 Refer to figure 4-2 for test setup. Disconnect one lead and check with lamp tester. The lamp should not light when the test leads are placed across the surge protector in either direction. If the lamp lights it indicates a shorted surge protector. Replace defective surge protector with one of the same operating characteristics as the surge protector installed in the generator at the factory. Order by part number and include the serial number of the generator. Following replacement of the surge protector, make certain field lead tie-down lacing is securely wound on shaft and tied.

#### 4.10 EXCITER ARMATURE AND ROTATING RECTIFIER ASSEMBLY REMOVAL

4.10.1 The following procedures describe removal of exciter armature and rotating rectifier assemblies which have the rotating rectifier assembly either inboard or outboard of the exciter armature assembly. Remove exciter armature and rotating rectifier bridge assembly as a unit as described in the following general instructions.

- a. Remove exciter cover. Disconnect generator field leads from positive (+) and negative (-) terminals. Remove exciter armature retaining bolt and washer.

- b. The exciter armature is a "slip fit" on the generator shaft. If the armature cannot be removed by hand, remove with a puller installed as described in step (c).
- c. Install a cap or plug to protect the shaft center. Utilizing the tapped holes in the end of sleeve, bolt to the end of the sleeve spacers and a metal plate. Refer to figure 4-5 for fixture setup.
- d. Hook a bearing puller to the metal plate and pull exciter armature and rotating rectifier assembly from the shaft.

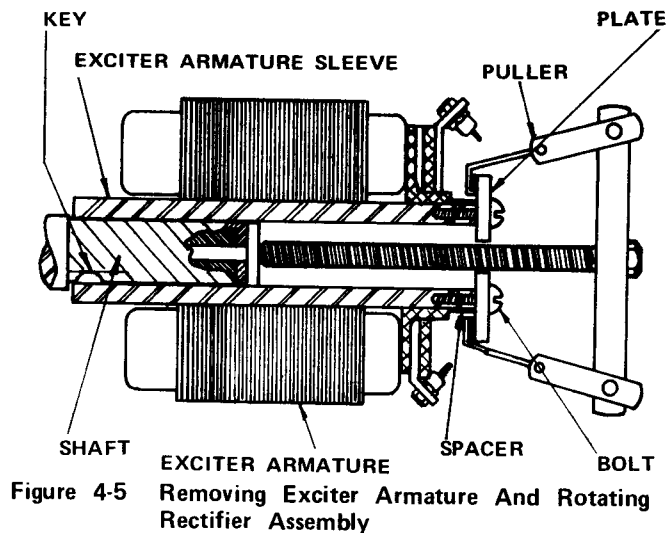

Figure 4-5

Removing Exciter Armature And Rotating Rectifier Assembly

#### 4.11 EXCITER ARMATURE AND ROTATING RECTIFIER ASSEMBLY INSTALLATION

4.11.1 The following procedures describe installation of exciter armature and rotating rectifier assemblies which have the rotating rectifier assembly either inboard or outboard of the exciter armature. Install exciter armature and rotating rectifier assembly as a unit as described in the following general instructions.

- a. If the "slip fit" exciter armature and rotating assembly will not easily slide onto the shaft by hand install with a fixture as shown in figure 4-6 and described in step (b).

#### NOTE

Usually the exciter armature will slide onto the shaft most of the way by hand. The exciter armature can usually be "seated" by tapping lightly on the sleeve with a soft rubber or fiber mallet.

**MAKE CERTAIN MALLET HITS ONLY THE SLEEVE, NOT RECTIFIER ASSEMBLY OR ARMATURE WINDINGS.**

- b. Refer to figure 4-6 for fixture setup. Start exciter armature and rectifier bridge on shaft. Thread stud in rotor shaft. Install large diameter washers on stud and start stud nut. Pull exciter armature and rotating rectifier onto shaft by turning stud nut. Make certain key is in place (see figure 4-6).

#### NOTE

On some models, a slot in the shaft and a lug on the sleeve is used in place of a key. Also, on some units, a pin in the shaft engages a slot in the sleeve. If unit is of either of these configurations, make certain lug or pin is aligned and engages slot in the exciter armature assembly sleeve.

- c. Remove stud and then re-install exciter armature retaining bolt and washer. Connect alternator field leads to positive (+) and negative (-) terminals on heat sinks. Re-install exciter cover.

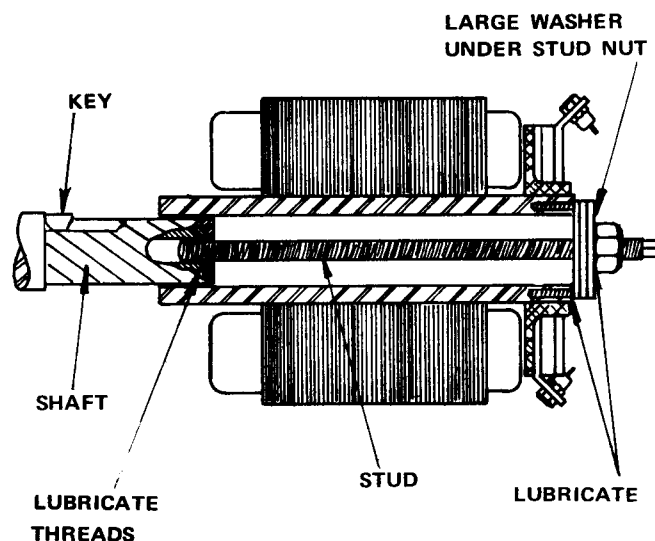

Figure 4-6 Installing Exciter Armature And Rotating Rectifier Assembly

#### 4.12 REMOVING AND REPLACING EXCITER STATOR ASSEMBLY

4.12.1 Should it be necessary to remove the exciter stator assembly, refer to "Generator Disassembly" procedures and then remove the stator as described in the following general instructions.

- a. Remove exciter cover and exciter armature. Refer to paragraph 4.10.1.
- b. Disconnect exciter field leads F1 and F2. Remove any clips securing exciter field leads to the exciter frame, generator frame or the endbell.
- c. Remove generator exciter and generator endbell. Refer to Motor-Generator Assembly and Disassembly Procedures. Check for shims in endbell bearing well. Make certain the shims, if incorporated, are re-installed when generator is re-assembled.

d. Remove bolts securing exciter frame and stator to the endbell.

e. Assemble stator by reversing disassembly procedures.

#### 4.13 RESTORING RESIDUAL MAGNETISM

4.13.1 The direct current necessary to magnetize the alternator field is obtained from the exciter. Initially, upon starting the generator, current flow and voltage is induced into the exciter armature by the magnetic lines of force set up by the residual magnetism of the exciter field poles. Residual magnetism of the exciter field poles may be lost or weakened by a momentary reversal of the field connection, a strong neutralizing magnetic field from any source, or if the generator is not operated for a long period of time. To restore the small amount of residual magnetism necessary to begin the voltage build-up, connect a battery of from 6 to 32 volts to the exciter field coil circuit. Normally a battery of 6 to 12 volts is large enough. When the field windings have a high resistance (75-100 ohms) a larger battery voltage may be required. Connect the battery and flash field as follows:

- a. Disconnect exciter field coil wire F2 at terminal F2.
- b. Connect battery positive lead to field coil lead F2.
- c. Connect battery negative lead to field coil circuit terminal F1.
- d. Disconnect battery leads after approximately 3 to 5 seconds. If battery is connected for too long, overheating and subsequent damage to the exciter could occur.
- e. Reconnect field coil lead F2 to terminal F2.
- f. Start unit and observe generator buildup. If generator output voltage does not buildup, reflash field (steps (a) through (e) above).

#### NOTE

If the polarity of the exciter is reversed by flashing the field it may be corrected by interchanging the battery leads.

#### 4.14 BEARING LUBRICATION

4.14.1 The bearings are of the factory lubricated shielded type on most KATO generators under 75 KW in size. These bearings are greased for the life of the bearing and should not

be serviced. If there is an indication of bearing failure, refer to trouble shooting chart, disassemble the machine and replace the bearing. Order bearings by the part number and include the model and serial number of the generator. Inspection and repacking of bearings during major overhaul of the prime mover or generator may be desirable. If bearings are to be repacked, thoroughly clean and inspect bearings and then pack about ½ full using a good grade electrical motor ball bearing grease which will lubricate satisfactorily to a temperature of +240 degrees Fahrenheit.

4.14.2 Most KATO Generators over 75 KW in size or with 18 inch diameter or larger stators have grease fittings and grease relief valves installed in the bearing housing to permit periodic replenishment of grease. Periodically lubricate bearings with the amount of grease and at the intervals given on the bearing lubrication plate attached to these generators. Use a good grade electrical motor ball bearing grease which will lubricate satisfactorily at a temperature of +240 degrees Fahrenheit.

#### 4.15 REMOVING BEARINGS

4.15.1 Remove the endbell to expose bearing. Refer to Motor-Generator Assembly and Disassembly Procedures. Use a puller to remove the bearing from the shaft. Protect the shaft end with a cap. If bearing is going to be used again, make certain puller applies pressure only against the bearing inner ring. If puller will not hook bearing inner ring, fabricate a split bushing and install it between the bearing and the puller hooks.

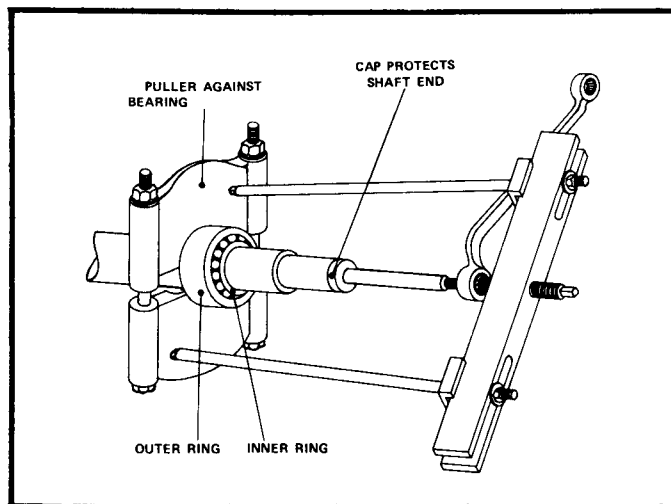

Figure 4-7 Removing Bearing

## 4.16 INSTALLING BEARINGS

4.16.1 Heat the bearing to 250 degrees Fahrenheit in a clean temperature controlled circulating air oven. Start the heated bearing onto the shaft. Then use a fiber or soft metal sleeve to tap bearing into place. See figure 4-8. Make certain that pressure is applied only to the bearing inner ring. Press bearing onto shaft until bearing inner ring rests against the bearing shoulder on the shaft. Assemble the motor-generator after the bearing has cooled.

## 4.17 TROUBLESHOOTING

4.17.1 Troubleshooting is the process of recognizing malfunctions of the system, intelligently analyzing the malfunction, and making the necessary corrections to place the unit back into proper operation.

4.17.2 Between regular preventive maintenance inspections, be alert for any signs of generator set trouble.

Common symptoms are listed in following tables. Correct any minor trouble immediately. **Minor defects left uncorrected can cause serious damage which can result in costly repairs and down time.**

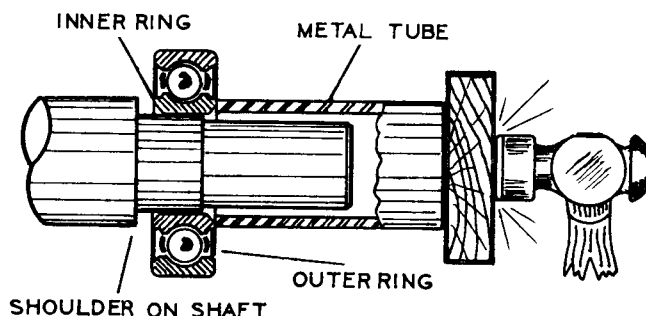

Figure 4-8 Installing Bearing

## TABLE B TROUBLESHOOTING CHART BRUSHLESS AC GENERATOR

SYMPTOM	POSSIBLE CASUES	REMEDY
No Voltage	Open circuit breaker or fuses (if voltage is sampled on load side of fuses or circuit breaker).	Check. Reset circuit breaker or replace fuses if open.
	Overvoltage, undervoltage, or overload devices tripped (when protective devices incorporated in circuit).	Check for cause of abnormal condition. Correct any deficiencies. Reset devices. Check Generator Data Plate for nominal operating values.
	Open circuit in exciter field.	Check out continuity of shunt field and leads to voltage control. (Use ohmmeter or wheatstone bridge.) If open in field coils, remove exciter field assembly and return assembly to factory for repair.
	Loss of residual magnetism in exciter field poles.	Adjust manual adjust potentiometer to full resistance. Flash field by making a flash connection of D.C. across terminals F1 to F2. See "Restoring Residual Magnetism"
	Open circuit in stator windings.	Check for continuity in windings. Return to factory for repair if open.
	Open circuited manual field rectifiers.	Check rectifiers, replace faulty diodes or rectifier assembly.
	Open circuit in manual voltage adjust circuit.	Check potentiometer for continuity. Replace if open circuit.
	Malfunction of automatic voltage regulator.	See trouble shooting of voltage regulator. Correct deficiencies.

SYMPTOM	POSSIBLE CAUSES	REMEDY
No Voltage	<p>Short circuited generator output leads.</p> <p>Open in rotating rectifiers.</p> <p>Open in alternator field.</p> <p>Shorted surge protector.</p> <p>Shorted rotating rectifiers.</p> <p>Shorted exciter armature.</p> <p>Shorted leads between exciter armature and generator field.</p>	<p>Clear lead to restore voltage build up.</p> <p>Check rotating rectifiers and replace if open.</p> <p>Check for continuity and return rotor to factory for repair if field coils are open.</p> <p>Check for shorts and replace.</p> <p>Check shorts and replace if faulty.</p> <p>Check for short, if faulty replace.</p> <p>Test and repair.</p>
Low Voltage	<p>Defective voltage regulator (when used).</p> <p>Defective diodes in stationary rectifier assembly (when used).</p> <p>Improper adjustment of voltage adjust rheostat.</p> <p>Excessive load.</p> <p>Line loss.</p> <p>High resistance connections. Connections will be warm or hot.</p> <p>Shorted field</p> <p>Low Power factor.</p> <p>Weak field due to operating in warm temperature.</p> <p>Improper voltage and/or frequency to drive motor causing low speed.</p> <p>Excessive load.</p>	<p>Check regulator, adjust or repair or replace if defective.</p> <p>Check rectifier assembly. Replace defective diode.</p> <p>Adjust rheostat.</p> <p>Reduce load. With 3 wire, single phase and 4 wire, three phase generators, the load on each leg should be as evenly balanced as possible and should not exceed the rated current on any leg.</p> <p>Increase size of line wire.</p> <p>Make better connections.</p> <p>Test field coils for possible short by checking resistance with an ohmmeter or resistance bridge. Return rotor assembly to factory for repair if alternator field coils are shorted.</p> <p>Reduce inductive (motor) load. Some AC motors draw approximately the same current regardless of load. Do not use motors of larger horsepower rating than is necessary to carry the mechanical load.</p> <p>Improve the ventilation of generator. Field current can be increased providing the generator temperature rating stamped on the nameplate is not exceeded.</p> <p>Check input voltage. Correct deficiencies. Check motor data plate for nominal operating values.</p> <p>Reduce load to rated value.</p>

SYMPTOM	POSSIBLE CAUSES	REMEDY
Low Voltage	<p>Defective bearing.</p> <p>Low speed due to motor running below rated RPM.</p>	<p>Replace bearing.</p> <p>Check frequency and voltage of motor incoming power.</p>
Fluctuating Voltage	<p><b>Voltage regulator, if used, not operating properly.</b></p> <p>Motor speed fluctuating.</p> <p>Loose terminal or load connections.</p> <p>Generator overloaded.</p> <p>DC excitation voltage fluctuating.</p>	<p>Check regulator. Repair or replace if defective.</p> <p>Check frequency and voltage of motor incoming power.</p> <p>Make better connections.</p> <p>Reduce load to rated value.</p> <p>Trace DC excitation circuit. Correct any defects.</p>
High Voltage	<p>Motor overspeed</p> <p>Improper adjustment of voltage adjust rheostat or voltage regulator.</p>	<p>Check voltage and frequency of motor incoming power.</p> <p>Adjust rheostat and/or voltage regulator.</p>
Overheating	<p>Clogged ventilating screens and air passages.</p> <p>Dry or defective bearings.</p> <p>Generator field coils shorted or grounded.</p>	<p>Clean all screens and air passages.</p> <p>Replace defective bearings.</p> <p>Test field coils for shorts. Replace shorted rotor or return to factory for repair.</p>
Vibration	<p>Defective or dry bearings.</p> <p>Rotor not balanced. (Following motor - generator repair)</p> <p>Generator not properly mounted.</p> <p>Transfer of vibration to generator from another source.</p>	<p>Replace defective bearings.</p> <p>Contact KATO Engineering Company for balancing instructions.</p> <p>Check mounting. Correct defective mounting.</p> <p>Isolate generator set from source of vibration by installing vibration dampeners between the generator set base and foundation.</p>

# TABLE C TROUBLESHOOTING CHART

## INDUCTION MOTOR TROUBLE SHOOTING CHART

SYMPTOM	POSSIBLE CAUSES	REMEDY
Motor fails to start	<p>Improper input voltage frequency.</p> <p>Input fuses, circuit breaker or contactors open.</p> <p>Load too heavy.</p>	<p>Check motor nameplate rating and wiring connection drawings correct input power.</p> <p>Replace or reset.</p> <p>Disconnect load. See if motor starts. Reduce load.</p>
Vibration	<p>Misalignment of endbells.</p> <p>Defective bearings.</p>	<p>Realign endbells.</p> <p>Replace defective bearings.</p>
Motor Overheating (check with thermometer)	<p>Overload</p> <p>Dirt in motor.</p> <p>Defective bearings.</p> <p>Shorted stator windings.</p> <p>Grounded.</p>	<p>Measure load; check with name plate rating. Check for excessive friction in MG set. Reduce load if excessive.</p> <p>Check flow of coolant air. Clean ventilating ports.</p> <p>Replace bearings.</p> <p>Replace stator or return to factory for repair.</p> <p>Check circuit with test lamp and repair.</p>
Excessive hum	<p>High voltage.</p>	<p>Check input voltage and motor for proper connection. Correct voltage or motor connections.</p>
Regular Clicking	<p>Foreign matter in air gap.</p>	<p>Check and clean.</p>
Overheating	<p>Operating with excessive voltage.</p> <p>Low power factor.</p> <p>Unbalanced load on 3 wire, single phase or 4 wire, 3 phase generator.</p> <p>Motors operating off generators not designed for generator frequency and voltage.</p> <p>Bent shaft.</p> <p>Endbells out of position.</p> <p>Defective bearing.</p>	<p>Check voltage drop in distribution lines and connections and adjust voltage as described in voltage deviation instructions.</p> <p>Reduce inductive load (motors) or install power factor improvement capacitors.</p> <p>The load on each leg should be as evenly balanced as possible and should not exceed the rated current on any leg.</p> <p>Install motors with correct voltage and frequency characteristics.</p> <p>Return rotor to factory for repair.</p> <p>Align endbells so that the air gap between the rotating part and the stationary part is equal at all points.</p> <p>Replace bearing.</p>

SYMPTOM	POSSIBLE CAUSES	REMEDY
Excessive Vibration	Dry or defective bearing. Rotor rubbing on stator. Loose lamination. Improper mounting of motor generator assembly.	Replace bearing. Replace worn bearings. Return to factory for repair. Check mounting. Install or level mounting feet (Vibration dampners) to reduce vibration.
Rapid knocking	Defective or contaminated bearing.	Replace bearing.
Bearing Overheating	Dry, worn or contaminated bearing. Misalignment of endbells. (Following repair of motor - generator)	Replace bearing Realign endbells

#### 4.18 ASSEMBLY AND DISASSEMBLY OF KATO COMMON FRAME MOTOR-GENERATOR WITH COOLING FAN MOUNTED OUTBOARD OF THE MOTOR ROTOR

4.18.1 Refer to figure 4-9 for part identification then dis-assemble generator as described in the following general instructions.

- a. Remove terminal box cover and disconnect generator load leads, exciter field leads and motor incoming power lines. Tag leads and terminals to make certain leads are correctly connected when unit is re-assembled.
- b. Remove bolts securing generator base pads (16) to engine-generator base or foundation.
- c. Move generator to location affording sufficient room for disassembly. Attach slings to lifting eyebolts (13) to move generator. See installation instructions for handling precautions.
- d. Remove exciter cover (1). Disconnect alternator field leads, remove exciter armature retaining bolt and washer (2). Remove exciter armature and rotating rectifier assembly as a unit.
- e. Remove clips securing exciter field leads to exciter frame, generator frame and generator endbell.

- f. Remove endbell bolts (9). Remove endbell (10). Tap lightly with rubber or fiber mallet to loosen endbell. Check for shims in the endbell bearing housing. Make certain shims, when incorporated, are re-installed when unit is re-assembled.
- g. If the exciter field (5) requires repair or replacement, remove bolts (7) and remove exciter field assembly (5) from endbell (10).
- h. Remove bolts (18). Remove endbell (17).
- i. Remove bolts from fan hub (15). Mark position of hub on shaft to aid in locating fan on shaft when unit is re-assembled. Remove fan from shaft.
- j. Install pipes over motor-generator shaft on the drive and exciter end of rotor. Attach slings and hoist to pipes and remove rotor assembly from stator and frame. Make certain air gap is maintained between the rotor and stator during removal of the rotor.

#### CAUTION

**Make certain pipes are of sufficient strength to support weight of rotor and that pipes do not have rough edges which would damage shaft surfaces.**

- k. Assemble motor-generator by reversing order of disassembly procedures listed above (steps (j) through (a)).

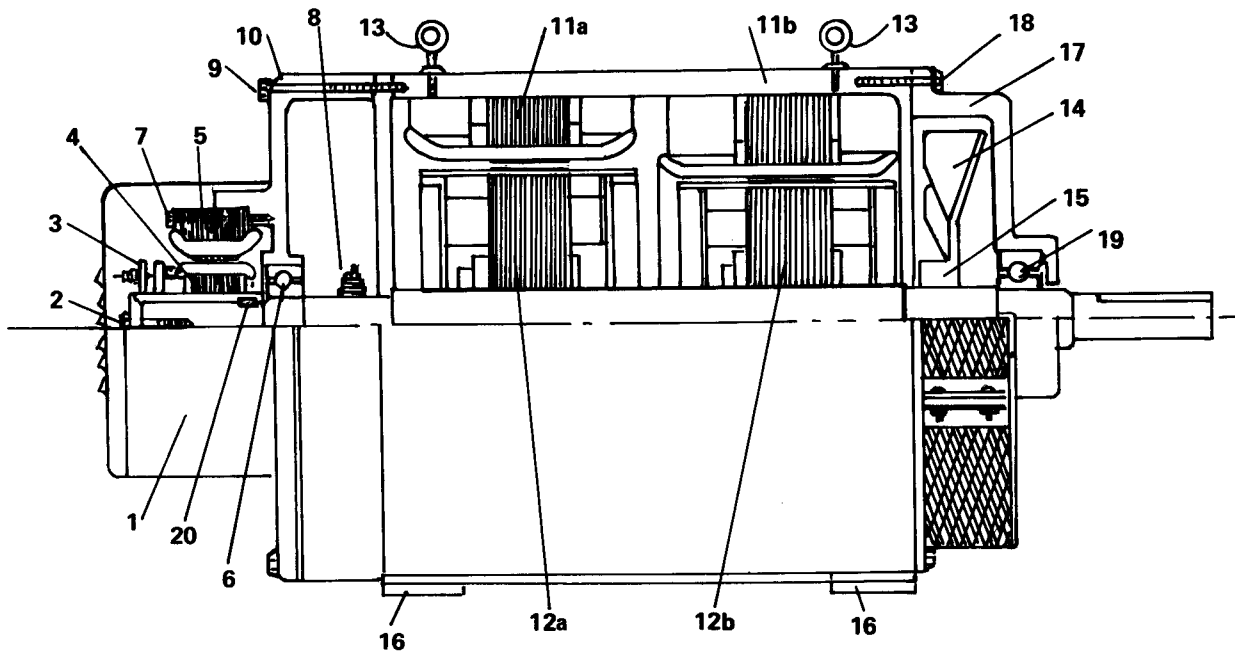

**Figure 4-9 KATO Common Frame Brushless Motor-Generator Assembly consisting of a Brushless Revolving Field Generator, Brushless Exciter and Induction Motor - Cooling Fan located outboard of Motor Rotor**

Key No.	Part Description
1	Exciter Cover
2	Exciter Armature Retaining Bolt & Washer
3	Rotating Rectifier Assembly
4	Exciter Armature Assembly
5	Exciter Field
6	Bearing, Exciter End
7	Exciter Field Mounting Bolt
8	Surge Protector (mounted on rotating rectifiers on some units)
9	Endbell Mounting Bolt
10	Endbell

Key No.	Part Description
11a	Generator Stator Assembly
11b	Motor Stator Assembly
12a	Generator Rotor Assembly
12b	Motor Rotor Assembly
13	Lifting Eyebolt
14	Fan
15	Fan Hub
16	Generator Mounting Pads
17	Drive Endbell
18	Drive Endbell Mounting Bolt
19	Bearing, Drive End
20	Exciter Armature Retaining Key

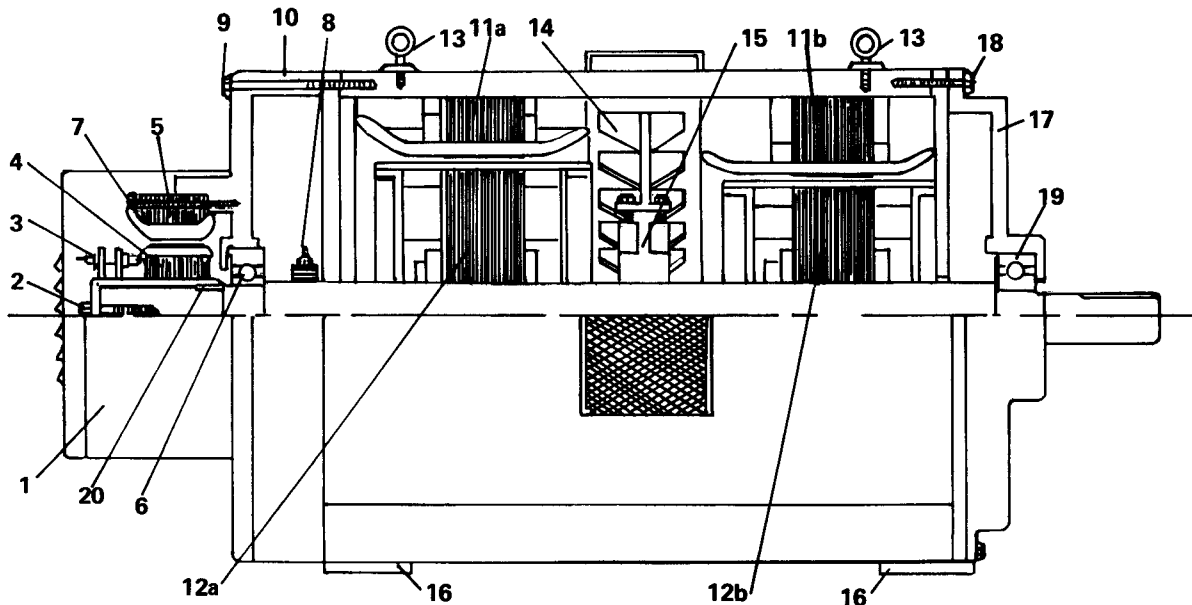

**Figure 4-10 KATO Common Frame Brushless Motor-Generator Assembly consisting of a Brushless Revolving Field Generator Brushless Exciter and Induction Motor - Unidirectional Cooling Fan mounted between generator and motor rotor.**

#### **4.19 ASSEMBLY AND DISASSEMBLY OF KATO COMMON FRAME MOTOR-GENERATOR WITH UNIDIRECTIONAL COOLING FAN LOCATED BETWEEN MOTOR AND GENERATOR ROTOR.**

4.19.1 Refer to figure 4-10 for part identification, then disassemble motor-generator as listed in the following general instructions.

- a. Disconnect generator and proceed with disassembly as described in 4.18.1 steps (a) through (e).
- b. Remove fan screen. Remove fan blades from fan hub. Mark each blade and the fan hub for direction of rotation. Number the fan blades and the fan hub as each blade segment is removed to ensure proper re-installation.

#### **NOTE**

**Fan blades must be re-installed in the correct direction of rotation. The rotor assembly was factory balanced with fan blades installed. Each blade segment must be re-installed to the identical position on the hub as when removed. Blades and hub must be clearly marked during disassembly to ensure correct re-assembly.**

- c. When removal of fan blades and identification marking of blades and hub is complete and satisfactory proceed with disassembly of the motor-generator.
- d. Remove endbell bolts (9). Remove endbell (10). Tap lightly with fiber mallet to loosen endbell. Check for shims in the endbell bearing housing. Make certain shims, when incorporated, are re-installed when unit is assembled.

- e. If the exciter field (5) requires repair or replacement, remove bolts (7) and remove the exciter field assembly (5) from endbell (10).
- f. Remove endbell bolts (18). Remove endbell (17). Check for shims in bearing housing. Make certain that shims, when incorporated, are re-installed when the unit is assembled.
- g. Install pipes over motor-generator shaft on the drive and the exciter end of the rotor assembly. Attach slings and hoist to pipes and remove rotor assembly from the stator. Make certain air gap is maintained between the rotor and stator during removal of the rotor.

#### **CAUTION**

**Make certain pipes are of sufficient strength to support weight of rotor and that pipes do not have rough edges which would damage shaft surface.**

- h. Assemble motor-generator by reversing order of disassembly procedures listed above (steps (g) through (a)).

#### **4.20 RENEWAL PARTS ORDERING INFORMATION**

4.20.1 Renewal part must be of the same physical construction and have the same operating characteristics as parts installed in the generator at the factory. **Do not attempt to substitute "similar" parts.** Order parts by part name and part number. As additional information, always include the generator serial number and the generator and exciter type and model numbers. For fastest service, direct parts order to KATO ENGINEERING COMPANY, Parts and Service Department, Mankato, Minnesota 56001.



## Kato Engineering Support

The brand you trust, the power you depend on. Include the serial number and model number for your machine in the email subject line.

Field Service	<a href="mailto:KatoService@mail.nidec.com">KatoService@mail.nidec.com</a>
Parts	<a href="mailto:KatoParts@mail.nidec.com">KatoParts@mail.nidec.com</a>
Remanufacturing	<a href="mailto:KatoRemanufacturing@mail.nidec.com">KatoRemanufacturing@mail.nidec.com</a>
Warranty/Quality Assurance	<a href="mailto:KatoWarranty@mail.nidec.com">KatoWarranty@mail.nidec.com</a>

---

Kato Engineering, Inc. | P.O. Box 8447 | Mankato, MN USA 56002-8447 | Tel: 507-625-4011  
[KatoEngineering@mail.nidec.com](mailto:KatoEngineering@mail.nidec.com) | [www.KatoEngineering.com](http://www.KatoEngineering.com) | Fax: 507-345-2798