

Instruction Manual

Installation
Operation
Maintenance

Motor-Generator Set
Synchronous
Common Shaft

Publication
350-03006-00 (07/18/2012)

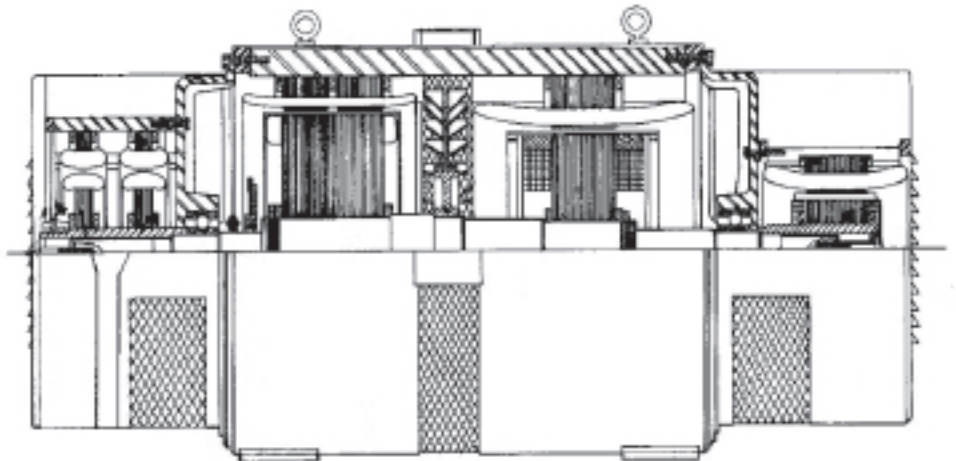

Nidec
KATO ENGINEERING™

Kato Engineering, Inc. | P.O. Box 8447 | Mankato, MN USA 56002-8447 | Tel: 507-625-4011
KatoEngineering@mail.nidec.com | www.KatoEngineering.com | Fax: 507-345-2798

Copyright © 2012 Kato Engineering, Inc. All rights reserved

Table of Contents

Introduction.....	4
Foreword.....	4
Safety instructions.....	4
Ratings/description.....	4
Construction and Operating Principles.....	5
Stator.....	5
Rotor.....	5
Brushless exciters.....	6
Installation.....	7
Receiving inspection.....	7
Unpacking and moving.....	7
Location.....	7
Mounting.....	8
Electrical connections.....	8
Operation.....	9
Pre-operation equipment check.....	9
Initial startup procedures.....	9
Maintenance.....	10
Schedules.....	10
Maintenance procedures.....	11
Winding inspection.....	11
Cleaning.....	13
Drying windings.....	14
Testing rotating rectifiers with an ohmmeter.....	15
Testing rotating rectifiers with a test lamp.....	16
Testing the surge protector.....	17
Restoring residual magnetism.....	17
Bearing lubrication.....	18
Assembly and disassembly.....	18
Exciter armature & rotating rectifier removal.....	19
Exciter armature & rotating rectifier installation.....	20
Removing bearings.....	20
Installing bearings.....	21
Troubleshooting guide.....	23
Appendices.....	25
List of equipment required for installation and maintenance.....	25
Overview drawings and parts list.....	26

Note: Because of rapid changes in designs and processes and the variability of Kato Engineering's products, information in this manual must not be regarded as binding and is subject to change without notice.

The image on the front cover is representative only. Several variations are available within the range of generators covered within this manual.

Notes and maintenance records

Introduction

Foreword

This manual contains instructions for installing, operating and maintaining Kato Engineering synchronous, common-shaft motor-generators. These generators are manufactured in many sizes and ratings and with various options.

Lubrication information, electrical connection drawings, dimensional drawings, parts listings and information on controls for your model are contained in the manual package as supplementary information and are the specific source of information for making connections and ordering replacement parts. Information about optional components for your generator may also be contained as a supplement.

Please read this manual in its entirety before unpacking, installing, and operating your motor-generator.

Safety instructions

In order to prevent injury or equipment damage, everyone involved in installation, operating and maintenance of the generator described in this manual must be qualified and informed of the current safety standards that govern his or her work.

The following paragraphs define warnings, cautions, and notes as they are used in this manual:

Warning: Warnings identify an installation, operating or maintenance procedure, practice, condition, or statement that, if not strictly followed, could result in death or serious injury to personnel.

Caution: Cautions identify an installation, operating or maintenance procedure, practice, condition, or statement that, if not strictly followed, could result in destruction of or damage to equipment or serious impairment of system operation.

Note: Notes highlight an installation, operating or maintenance procedure, condition, or statement and are essential or helpful but are not of known hazardous nature as indicated by warnings and cautions.

Ratings/description

Nameplates, which are located on the side of the generator and motor, include serial and model number as well as rating information and bearing and lubrication information.

Construction and Operating Principles

General description:

The motor-generator (MG) set consists of either a common frame for both motor and generator or two separated frames bolted together through a common adapter.

The rotors for both the motor and generator are mounted on a common shaft, thus eliminating the need for couplings and for aligning a separate motor and generator. The brushless exciters are mounted at either end of the shaft, and on some models, dual exciters are mounted at one end.

An optional permanent magnet generator can be mounted on a common frame with the brushless exciter.

Typically a single blower is mounted between the motor and generator rotor. The blower forces the cooling air to enter at each end and discharge through the middle. Some models may have a single blower mounted at one end, which causes the fresh air to enter at one end and discharge at the other end.

Some models also have a “pony motor” mounted on one end to start the motor-generator set and accelerate it to rated speed.

The shaft is supported at each end by re-greaseable ball bearings. Grease fittings are provided on each endbracket for easy replenishing of the bearing grease. Sealed type bearings are furnished on small MG sets and cannot be regreased.

Stators

The stators consist of the supporting frame, core, and armature windings.

The stator core is made from laminations, thin sheets of electrical steel that are stacked and held in place by steel endrings and support bars. The rings and bars are welded to or are part of the steel frame.

The windings (coils) are constructed of layered and insulated copper wire. The coils are inserted in the core slots, connected together, and the entire assembly is vacuum-pressure impregnated with resin. Stator leads terminate in standard connection lug or strap terminals for ease of connection by the end user.

Rotors

The field poles are made of laminations that are rived under pressure. The field poles are layer wound to form the field windings. Damper bars are inserted below the surface of the poles and are brazed to a shorting ring or copper end laminations. The entire field winding is vacuum-pressure impregnated with resin.

Brushless exciters

The brushless exciters are inverted synchronous AC generators with the stationary field windings (stator) and three-phase armature rotating with the generator rotor. The AC output is rectified through a full-wave semiconductor bridge.

Exciter Stator: The exciter stator is made up of steel laminations welded under pressure. In models with a permanent magnet, the laminations are welded into a frame, which also contains the permanent magnet stator. Field coils are inserted into the slots, and the entire assembly is vacuum-pressure impregnated with resin. The stator is bolted to endbrackets.

Exciter armature: The exciter armature consists of stacked laminations riveted under pressure. Three-phase windings are inserted in the slots, and the entire assembly is vacuum-pressure impregnated with resin. The exciter armature is pressed on a tube shaft, which is keyed onto the main rotor.

A three-phase full wave rectifier, made of three forward and three reverse diodes, are mounted on two separated metal rings, which act as negative and positive polarity heat sinks. The rectifier is pressed on the same tube shaft as the exciter armature.

The entire armature assembly is dynamically balanced and is slid over a key or onto a notch or pin on the main rotor shaft.

Installation

Receiving inspection

Before accepting a shipment, examine the packaging for any sign of damage that might have occurred during transit. Report any damage to the transportation company and the factory.

Unpacking and moving

If the motor-generator is received during cold weather, reduce condensation on cold surfaces and the possibility of failure due to wet windings by allowing the generator to reach room temperature before removing the protective packing.

Unpack the motor-generator carefully to avoid scratching the painted surface. Inspect for loosely mounted components and the presence of moisture. Inspect to make certain foreign material such as crating nails, loose bolts or packing material, which may have fallen into the machine during unpacking, are removed. If damage is noted, determine the extent of damage and immediately notify the transportation company claims office and the factory. Be sure to give complete and accurate details, including serial number, when reporting damage.

Move the motor-generator by attaching an overhead hoist to the lifting eyes installed on the generator frame or by lifting the generator from underneath the skid with a forklift.

Location

Install the motor-generator in an area so it complies with all local and industrial regulations. Locate it in a clean, dry, well-vented area or area that is suitable for the generator enclosure. Make sure it is easily accessible for inspection and maintenance.

Protect motor-generators operating intermittently in very damp locations with space heaters. Slowly warm motor-generators placed in operation after being subjected to very low temperatures to prevent excessive condensation. Check winding and insulation resistance before placing the generator in operation (see instructions later in this manual).

Wall mounted control cubicles can be mounted on any wall or steel bulkhead that will adequately support the weight of the control cubicle. The control cubicle and motor-generator frame must be grounded to a common ground. Interconnecting conduit between the motor-generator and control cubicle, as well as load lines, must be to local and national/international electrical codes.

Warning: *Be alert at all times when installing, operating and maintaining the motor-generator. Avoid contact with the uninsulated metal parts of the motor-generator. Most injuries occur from faulty ground connections on portable electrical equipment and failure to ground stationary equipment.*

Apply lifting force to structural points specifically provided for lifting. Do not use the enclosure lifting holes to lift the whole unit. Use lifting means adequate for the weight. Observe lifting notices attached to the generator. Failure to observe these instructions can result in personnel injury and damage to the generator.

Caution: *Blocking or restriction of normal air flow into or out of the motor-generator may cause damage to the electrical windings.*

The foundation that supports the motor-generator must be rigid, level and of ample size and strength. Although a reinforced concrete foundation usually is best, the motor-generator may be placed on any concrete, steel, or other structural material that will adequately support the weight of the unit. Bearing loads of structural material can be obtained by referring to engineering handbooks.

Mounting

If the motor-generator set has its own base and the foundation is slightly uneven, install shims under the motor-generator mounting pads until all pads are in contact with the foundation. Use a feeler gage to determine thickness of shims required.

Caution: Do not drop the MG, or the feet will move out of adjustment.

If the motor-generator has base mounting feet, lift the motor-generator set slightly until all base feet are clear of the foundation. Loosen the base foot mounting bolts, and move the base feet in the elongated slots until all base feet contact the foundation evenly. Tighten the base mounting bolts, and lower the motor-generator. See Figure 1.

Caution: Make sure the vibration dampeners are not over compressed, which would greatly reduce their effectiveness.

When the motor-generator set is installed in areas where noise or vibration would be a nuisance, these undesirable effects can be reduced or eliminated by installing vibration dampeners and sound dampening insulation. See Figure 1.

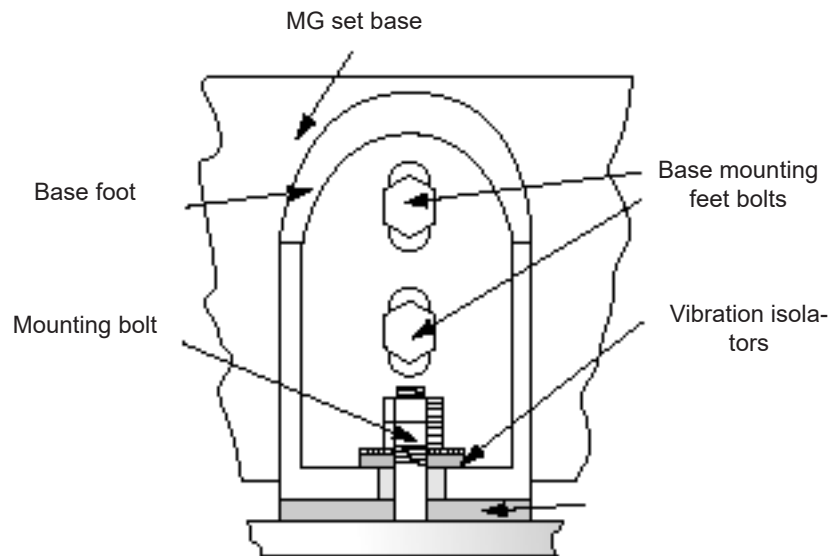

Figure 1: Base mounting feet

Warning: Do not attempt to make any changes in inter-wiring without contacting the factory. Serious injury and equipment damage could result.

Electrical connections

Before connecting the motor-generator to the electrical power load, check the nameplate for the electrical characteristics, and connect the unit exactly as shown in the connection diagrams. Refer to local and national/international code requirements for wire sizes, conduits and protective devices.

Operation

Pre-operation equipment check

After the motor-generator and control equipment is completely installed and wired but before operating the system for the first time, perform a check as follows:

1. If the motor-generator has been subjected to extreme dampness during shipment or storage, it may be necessary to dry out the windings before placing the unit in operation. Refer to the procedures for testing.
2. Check all interconnecting wiring against the connection diagrams supplied with the motor-generator and control equipment. Make sure that motor incoming power agrees with the nameplate rating.
3. Remove the exciter or fan cover and manually turn the motor-generator shaft to ensure it rotates freely without binding or rubbing.
4. Make sure all covers and guards are installed.

Initial startup procedures

1. Start the motor-generator. When the unit begins to accelerate, stop the motor generator. Check the rotation as the unit slows. If the rotation does not match the rotation arrows on the unit, reverse the incoming power phase. With three-phase motors, interchange any two incoming power lines.
2. Restart the motor-generator. Accelerate to rated speed. If the motor current ammeter is not incorporated in the controls circuitry, use a clip-on ammeter on any of the incoming power lines (except the neutral line). As the unit accelerates to rated speed, the line current will gradually decrease. When the MG set reaches synchronous speed, field excitation will be applied by the control system. At this point, the line current should be adjusted to minimum. If a field adjust rheostat/Variac is used, adjust the field motor current until the ammeter indicates minimum motor line current. Increase the field current (raise field voltage) slightly to be certain the motor will not pull out of step with full load.
3. Check for any unusual condition such as excessive noise, high bearing temperature, and excess vibration. Check the voltage on the generator. If automatic voltage regulation is used, check for rated voltage. If manual regulation is used, adjust the voltage to rated nameplate value.
4. Close the circuit breaker, and apply a load. Check the generator voltage regulation. Adjust generator exciter voltage to rated output. Adjust the motor field rheostat to maintain low motor line current with slightly greater motor field voltage than minimum requirement.

Note: If the motor-generator includes Kato Engineering control panels, your manual package will contain more detailed instructions for start up.

Note: The generator output circuit breaker must be disconnected from the load.

Caution: Do not change factory connections.

Caution: With an auto-manual voltage regulation system, do not actuate the auto-manual switch with full load applied to the generator connection output.

Copyright © 2012 Kato Engineering, Inc. All rights reserved

Warning: Do not service the motor-generator or other electrical machinery without de-energizing and tagging the circuits as out of service. Dangerous voltages are present, which could cause serious or fatal shock.

Maintenance

Schedules

A regular preventive maintenance schedule will ensure peak performance, minimize breakdowns and maximize motor-generator life. The schedule listed below is a guide for operating under standard conditions. Specific operating conditions may require reduced or increased maintenance intervals. Bearing maintenance should be performed according to bearing plate instructions.

Every day

Check the operating temperature of the stator windings and the air out.

Check the control panel voltmeter for proper stability and voltage output.

Every week

Visually inspect the bearing exterior for dirt, and clean if necessary.

Inspect any generator air filters for build up of contaminants, and clean or replace as required

Every 2000 Hours or 6 months of operation

Remove motor-generator outlet box cover. Visually inspect the stator leads and insulation for cracking or damage. Check all exposed electrical connections for tightness. Check transformers, fuses, capacitors, and lightning arrestors for loose mounting or physical damage. Check all lead wires and electrical connections for proper clearance and spacing.

Clean the inside of the outlet box, air screens, bearing housings, and air baffles with compressed air and electrical solvent if needed.

Check the vibration level, and compare it with the normal level.

Every 8000 hours or 1 year of operation

Check insulation resistance to ground on all motor-generator windings, including the main rotating assembly, the main stator assembly, the exciter field and armature assemblies, and the optional PMG assembly.

Check the space heaters for proper operation.

Check the rotating rectifier connection tightness.

Every 20,000 hours or 3 years of operation

Remove the enclosures, and visually inspect the end windings for oil or dirt contamination. Excessive contamination may necessitate surface cleaning with compressed air and electrical solvent.

Inspect the fan for damage.

Every 30,000 hours or 5 years of operation
(Contact Kato Engineering for assistance)

If inspection determines the need for major cleaning, disassemble the motor-generator (this includes rotor removal).

Clean the generator windings using either (depending upon the severity of contamination) 1) compressed air and electrical solvent or 2) degreaser and high pressure hot water wash. Dry the windings to acceptable resistance levels (see the dry out procedure).

Inspect the bearings for wear, and replace them if necessary..

Maintenance Procedures

Winding inspection

Contaminant on the windings develop conductive paths to produce shorts or grounds with subsequent failure. Contaminants can also cause heating, which shortens insulation life.

Examine insulation surfaces for cracks and accumulations of dirt and dust, and clean if necessary as described below.

A lower-than-normal insulation resistance can be an indication that conductive contaminant may be present and cleaning is necessary. Insulation resistance tests are based on determining the current through the insulation and across the surface when a DC megger voltage is applied. The leakage current is dependent upon the voltage and time of application, the area and thickness of the insulation, and the temperature and humidity conditions during the test.

The insulation resistance test is used to determine the insulation condition prior to application of more extensive testing measures. Refer to the following electrical measurement procedures for testing detail. Contact Kato Engineering or refer to IEEE Standard. 432-1992 when more extensive insulation tests are required.

Caution: *The insulation resistance tests are usually made on all or parts of an armature or field circuit to ground. They primarily indicate the degree of contamination of the insulating surfaces or solid insulation by moisture and other conducting influences and will not usually reveal complete or uncontaminated ruptures.*

Note: *The insulation resistance value increases with decreasing winding temperatures. All readings must be corrected to winding temperatures. Use Table 1 for converting megger readings to other temperatures (e.g., 100 megohms at 50° C is converted to 170 megohms: 1.7 x 100).*

Winding Temp (°C)	Conversion factor
10	0.23
20	0.37
30	0.6
40	1
50	1.7
60	2.7
70	4.5
80	7.5
90	14
100	23
110	38
120	61

Table 1: Temperature conversion factor for resistance readings

Warning: *Never apply the megger to the rotating rectifier, the voltage regulator, or generator accessories (e.g., temperature detectors, space heaters).*

Exciter fields (stators) and PMG armature (stator)

1. Disconnect the exciter leads from the terminals in the terminal box or the voltage regulator.
2. Connect exciter leads to one clamp of 500-volt megger, and connect the other clamp to the generator frame.
3. Apply 500 V from the megger, and measure the resistance reading after 1 minute. The reading must be a minimum of 1 megohm. If it is not, refer to the cleaning or dry out procedures.
4. Ground the exciter field leads to the generator frame for several minutes after the megger has been disconnected. This will allow the voltage build up to be properly discharged.

Exciter armatures

1. Disconnect the exciter armature leads from the rotating rectifiers.
2. Connect the leads of the exciter armature to one clamp of a 500-volt megger, and connect the other clamp to a suitable connection on the shaft.
3. Apply 500 V from the megger, and measure the resistance reading after 1 minute. The reading must be a minimum of 1 megohm. If it is not, refer to the cleaning or dry out procedures.
4. Ground the exciter leads to the shaft after disconnecting the megger. This will allow the voltage build up to be properly discharged.

Main rotors

1. Disconnect the generator field leads from the positive and negative terminals of the rotating rectifier assembly.
2. Connect the positive and negative leads to one clamp of the 500-volt megger, and connect the other clamp to the shaft.
3. Apply 500 V from the megger, and measure the resistance reading after 1 minute. The reading must be a minimum of 1 megohm. If it is not, refer to the cleaning or dry out procedures.
4. Ground the field leads to the shaft after disconnecting the megger. This will allow the voltage build up to be properly discharged.

Main stators

1. Disconnect power connections and all control apparatus from the generator and motor terminals.
2. Measure insulation resistance of each phase separately with the two other phases shorted to the frame.
3. Use a 500-volt megger connected between the lead(s) of the phase to be measured and generator frame. The minimum 1-minute insulation resistance must not be less than that given by the following formula:

$$\text{Resistance in megohms} = \frac{\text{Rated voltage} + 1000}{1000}$$

If it is less than above, refer to the cleaning or dry out procedures.

4. Ground the leads to the frame after the 1-minute megger test. This will allow the voltage build up to be properly discharged.

Cleaning

Cleaning the windings is advised if there is visual, electrical or thermal evidence of heavy accumulations of contaminant. Without such evidence, routine cleaning should be avoided.

Assembled machines: Where cleaning is required at the installation, and complete disassembly of the machine is unnecessary or not feasible, first pick up dry dirt, dust, or carbon with a vacuum cleaner to prevent the redistribution of the contaminant. A small non-conductive nozzle or tube connected to the vacuum cleaner may be required to reach dusty surfaces or to enter into narrow openings. After most of the dust has been removed, a small brush can be affixed to the vacuum nozzle to loosen and allow removal of dirt more firmly attached.

Use suction to used to remove dust within a machine. After the initial cleaning with vacuum, compressed air (not to exceed 30 lb/in²) may be used to remove the remaining dust and dirt. An exhaust must be provided so that dirt will be removed from the machine. Indiscriminate blowing may produce mechanical unbalance of an armature or rotating field by redistribution of dirt. Compressed air used for cleaning should be clean and free of moisture or oil. Air pressure or velocity should be adequately controlled to prevent mechanical damage to the insulation. Disassembly of the machine and more effective cleaning by a qualified service shop may be required if the previously described field service cleaning procedures do not yield effective results.

Note: With some units all phases are connected to neutral and cannot be grounded for this test.

Note: These cleaning instructions are taken from the IEEE Guide for Insulation Maintenance, Std. # 432-1992, which should be referenced for further information.

Disassembled machines: Take an initial insulation-resistance reading, as described above, on the machine to check electrical integrity. A zero reading may indicate an insulation breakdown requiring repair, not just cleaning.

The “steam-gun” method of cleaning, which sprays a high-velocity jet of hot water and water containing a mild detergent, is normally effective in cleaning windings including those subjected to flooding or salt contamination. Follow the detergent spray by multiple sprays with clean water to remove or dilute the detergent. Water immersion with multiple rinses and changes of water may also be used to remove contamination. Dry the machine (a low-temperature oven may be used) until normal insulation resistance values are obtained at room temperature.

Warning: *Take extreme care when using solvents both with respect to the equipment and the personnel. Consider the disposal of waste products, the possibility of damage to the insulation, and health and safety hazards for the worker when selecting a solvent. Use adequate ventilation and protective gear, including a dust mask, glasses and gloves, during equipment cleaning. Make sure the equipment is de-energized before cleaning.*

Solvents are effective for removing oil or grease and may be required if water or detergent is not adequate. However, solvents may carry contamination, such as conductive dusts, metals, salts and carbon, into cracks and crevices. Removal of contamination from such inaccessible areas is virtually impossible. A solvent dampened cloth is the preferred cleaning method rather than direct application of liquids.

Drying windings

If the insulation resistance readings are below the recommended minimum values specified previously, use one of the dry out procedures described below. Select the procedure based on the size and location of the unit, available equipment, and experience of personnel. Before drying, remove the voltage regulator.

Caution: *Do not apply heat too rapidly. It could damage the windings.*

Drying with external heat: Place heat lamps or space heaters (in addition to the ones already supplied). Monitor winding temperatures. Raise winding temperature gradually at a rate of 50° F (28° C) per hour up to 200° F (93° C). Measure insulation resistance at 1-hour intervals. Typically the insulation resistance will slowly drop while the temperature is coming up, and then gradually increase and level out.

Drying with AC current in the armature: Short circuit the generator terminals. Insert a current transformer and an ammeter to read full load current. Run the generator at rated RPM. Apply excitation to the exciter field until rated current is developed. Monitor winding temperatures until they stabilize. Continue running until insulation resistance values level off. Monitor winding temperatures. Raise winding temperature gradually at a rate of 50° F (28° C) per hour up to 200° F (93° C). Measure insulation resistance at 1-hour intervals. Typically, the insulation resistance will slowly drop while the temperature is coming up and then gradually increase and level out.

Use an inside-type growler and test each coil in the stator. Position the growler in the stator and hold a thin metal strip, similar to a hacksaw blade, parallel to the core slots. Energize the growler and explore the core surfaces approximately one pole distance on each side of the growler. Continue testing one core slot at a time until all coils are tested. If the winding is shorted, the metal strip will vibrate when held over the slot containing the faulty coil.

Testing rotating rectifiers with an ohmmeter

Rotating rectifiers (diodes) are illustrated in Figures 2 and 3. Compare the forward and reverse resistance of each diode. If one side of each diode is disconnected, a defective diode will be very easily detected. Each diode should show high resistance in one direction and a low resistance in the opposite direction.

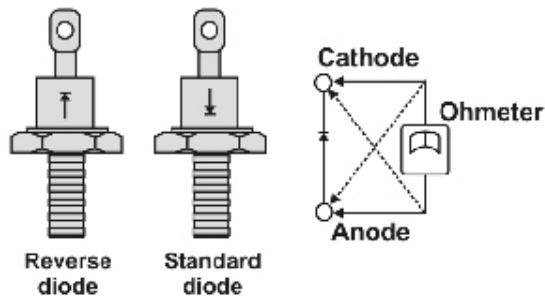

Figure 2: Testing rotating rectifiers with an ohmmeter

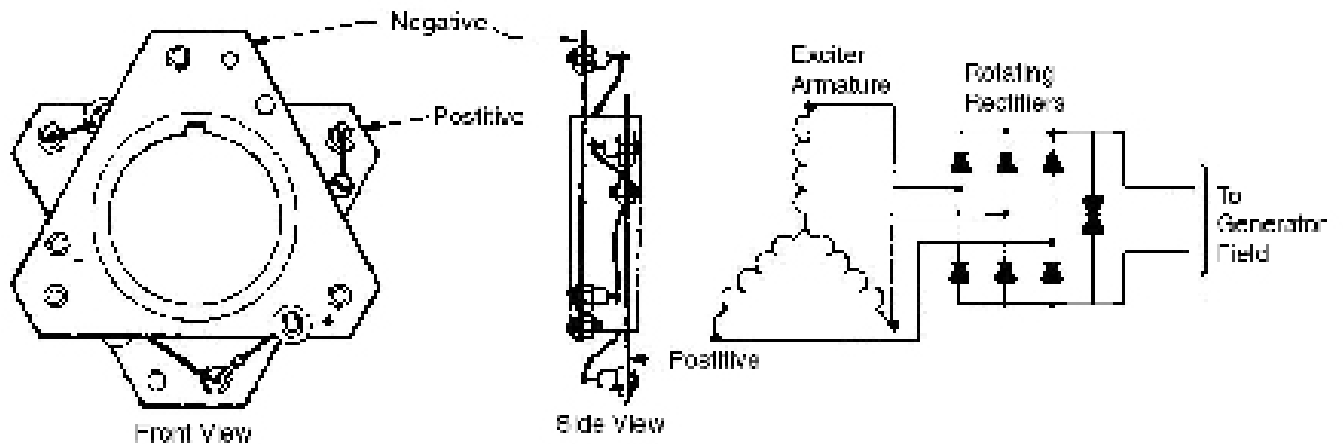

Figure 3: Rotating rectifier location and schematic, single rectifier unit

Note: In most applications, it is best to replace all six diodes if one faulty diode is found.

The diodes may also be tested without disconnecting them from the heat sinks or the exciter armature. The generator field lead wire, however, must be disconnected from the (+) and (-) terminals on the heat sink. The normal resistance of a surge suppressor is high enough so it can be left in the circuit. When testing diodes that are connected to the heat sink and exciter armature, a single shorted diode will give the same indication as if all diodes on the heat sink were shorted. An open diode will not, however, give a very obvious indication since current can flow through diodes in the circuit that are in good condition and give a comparatively low resistance. Therefore, when testing for an open diode without disconnecting the diodes from the heat sink, watch carefully to see whether the meter stabilizes immediately or whether there is a short delay in its swing, possible only a fraction of a second, due to the inductance in the armature winding. It may be helpful to compare all three diodes on the heat sink and look for small differences among them in repeatability of response of the meter.

Testing rotating rectifiers with a test lamp

A three-volt test lamp may be used in place of an ohmmeter to test the diodes of the rotating rectifier (see Figure 4). The procedure is basically the same as when an ohmmeter is used. The test lamp will light in both directions due to windings connected in parallel to the diode. When testing diodes connected to the heat sinks rather than individual diode test, a slight lag in the lighting of the test lamp bulb or a decrease in brilliance may be an indication that one of the diodes is open.

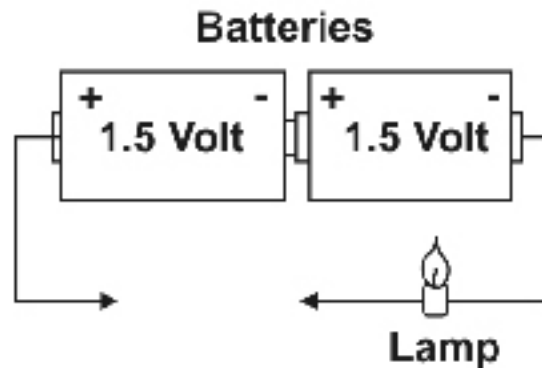

Figure 4: Testing rotating rectifiers with an ohmmeter

Testing the surge protector

The surge protector suppresses high voltage transients, which could otherwise damage the diodes in the rotating rectifier. It is mounted between the heat sinks on the rotating rectifier assembly.

The surge protector may be either a polarized or a non-polarized type. The polarized type has a red dot on the terminal that is attached to the positive heat sink and a black dot on the end that is attached to the negative heat sink.

Use an ohmmeter when testing the surge protector. The polarized type should have reverse resistance approximately 10 to 50 times the forward resistance. A non-polarized surge suppressor should have high resistance in both directions and will likely have signs of damage and an odor.

Restoring residual magnetism

The direct current necessary to magnetize the alternator field is obtained from the exciter. Initially, upon starting the generator, current flow and voltage is induced into the exciter armature by the magnetic lines of force set up by the residual magnetism of the exciter field poles. Residual magnetism of the exciter field poles may be lost or weakened by a momentary reversal of the field connection, a strong neutralizing magnetic field from any source, or if the generator is not operated for a long period of time. To restore the small amount of residual magnetism necessary to begin the voltage build up, connect a battery of from 6 to 32 volts to the exciter field coil circuit. Normally a battery of 6 to 12 volts is large enough. When the field windings have a high resistance (75-100 ohms) a larger battery voltage may be required. Connect the battery and flash field as follows:

1. Disconnect exciter field coil wire F2 at terminal F2.
2. Connect battery positive lead to field coil lead F2.
3. Connect battery negative lead to field coil circuit terminal F1.
4. Disconnect battery leads after approximately 3 to 5 seconds. If battery is connected for too long, overheating and subsequent damage to the exciter could occur.
5. Reconnect field coil lead F2 to terminal F2.
6. Start unit and observe generator build up. Re-flash field (Steps 1 through 5 above) if generator output voltage does not build up.

Note: *If the polarity of the exciter is reversed by flashing the field, it may be corrected by interchanging the battery leads.*

Bearing Lubrication

Sealed bearings - These bearings are used on small motor-generator sets. These bearings are factory packed about half full of a high quality ball bearing grease. Normally several years of operation can be expected before replacement of the bearings is required. Replace noisy bearings. During major overhaul, also replace the bearings.

Re-greaseable ball or roller bearings - Lubricate at intervals and amounts listed on the lubrication plate attached to the set. Use a high quality bearing grease, which will lubricate satisfactorily over a temperature range of lowest ambient temperature to 250° F (121° C.). Inspect noisy bearing and re-grease or replace them as necessary.

Assembly and disassembly (see Figures 7 and 8)

1. Remove the terminal box cover, and disconnect the generator load leads, exciter field, and motor incoming power lines. Tag the leads and terminals to make certain the leads are correctly connected when the unit is reassembled.
2. If you are going to move the MG, remove the bolts securing the motor-generator assembly base pads (23) to the foundation, and move the motor-generator to a location affording sufficient room for disassembly. Attach a slings and a hoist to the lifting eye bolts (20) in order to move the set. See the installation instructions for handling precautions.
3. Remove the exciter cover (1). Disconnect the field leads at the (+) and (-) terminals on the rotating rectifier assembly heat sinks. Remove the exciter armature retaining bolt and washer (2). Remove the exciter armature and rotating rectifier assembly as a unit as described below.
4. Remove the clips securing exciter field leads to the exciter frame, motor-generator frame and endbrackets.
5. Remove the fan screen. Remove the fan blades from the fan hub. Mark each blade and the fan hub for the direction of rotation. Number the fan blades and the fan hub as each blade segment is removed to ensure proper reinstallation.
6. Remove endbracket bolts (14). Remove the endbracket (15), tapping it lightly with fiber mallet to loosen it. Check for shims in the endbracket bearing housing. Make certain the shims, when incorporated, are reinstalled when the unit is reassembled.
7. Remove the endbracket bolts (25). Remove the endbracket (24). Check for shims in the bearing housing. Make certain that shims, when incorporated are reinstalled when the unit is assembled.

Note: *Fan blades must be reinstalled in the correct direction of rotation. The rotor assembly was factory balanced with the fan blades installed. Each blade segment must be reinstalled to the identical position on the hub as when removed. The blades and hub must be clearly marked during disassembly to ensure correct reassembly.*

Note: *The endbracket-to-bearing outer race is not a compress fit. Old grease may cause the bearing to stick in the endbracket.*

8. If the exciter stator (field) (8) or (9) requires repair or replacement, remove bolts (11) and remove the exciter field assembly from the endbrackets (15) or (24).
9. Install a pipe over the motor-generator shaft on the generator side of the rotor. Attach slings and a hoist to the pipe, attach another sling or other acceptable device to the motor-end of the shaft, and remove the rotor assembly from the stator and frame. Make certain the air gap is maintained between the rotor and stator during removal of the rotor.
10. Assemble the motor-generator by reversing the order of disassembly procedures. See Table 2 for torque values.

Caution: Make certain the pipe is of sufficient strength to support the weight of the rotor and that it does not have rough edges, which would damage shaft surface.

Exciter armature and rotating rectifier assembly removal

1. Remove the exciter cover. Disconnect generator field leads from positive (+) and negative (-) terminals. Remove exciter armature retaining bolt and washer.
2. Slide the assembly off. The assembly is a “slip fit” on the generator shaft. If it cannot be removed by hand, remove it with a puller:
 - Install a cap or plug to protect the shaft center. Using the tapped holes in the end of sleeve, bolt on a metal plate. Refer to Figure 5 for fixture setup.
 - Hook a bearing puller to the metal plate and pull the exciter armature and rotating rectifier assembly from the shaft.

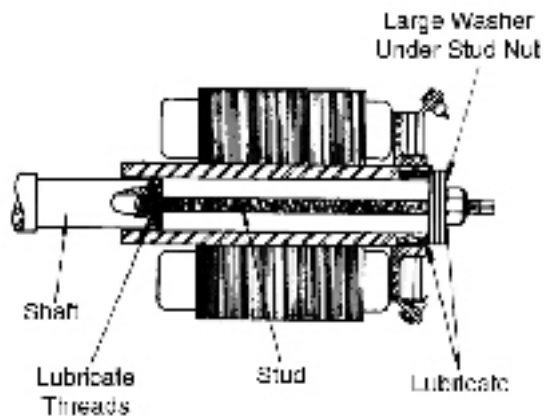

Figure 5: Installing the exciter armature and rotating rectifier assembly

Caution: Do not pound on the rectifier assembly or armature winding.

Note: A lug on the exciter sleeve that engages a slot in the shaft is used in place of a key in some models and a pin through the shaft that engages a slot in the sleeve is used in place of a key on some models. On these units, turn the exciter armature to position where lug and slot or pin and slot engage.

Exciter armature and rotating rectifier assembly installation

1. Make sure the shaft and inside of the sleeve are clean. Make certain the key, when used, is in place.
2. Slide the assembly onto the shaft most of the way by hand. The assembly can usually be “seated” by tapping lightly on the sleeve with a soft rubber or fiber mallet.
3. Install the exciter armature retaining bolt and washer. Torque the bolt to the requirements in Table 1. Connect the alternator field leads to the positive and negative terminals on the heat sinks. Reinstall the exciter cover.

Removing and replacing the exciter stator assembly

Should it be necessary to remove the exciter stator assembly, refer to the generator disassembly procedures, and then remove the stator as described in the following general instructions:

1. Remove exciter cover and exciter armature.
2. Disconnect exciter field leads F1 and F2. Remove any clips securing exciter field leads to the exciter frame, generator frame, or the end bell.
3. Remove bolts securing the exciter field to the endbracket.
4. Assemble stator by reversing disassembly procedures. Make certain leads are toward endbracket. Be sure the exciter field assembly is seated completely before securing the bolts.

Removing bearings

Remove the endbracket to expose the bearing, which is friction fit between the endbracket and the outer bearing race. Refer to the disassembly procedures. Use a puller to remove the bearing from the shaft as shown in Figure 6. Protect the shaft end with a cap.

Note: Heating the bearing inner race may be beneficial to remove the bearing after pulling pressure has been applied.

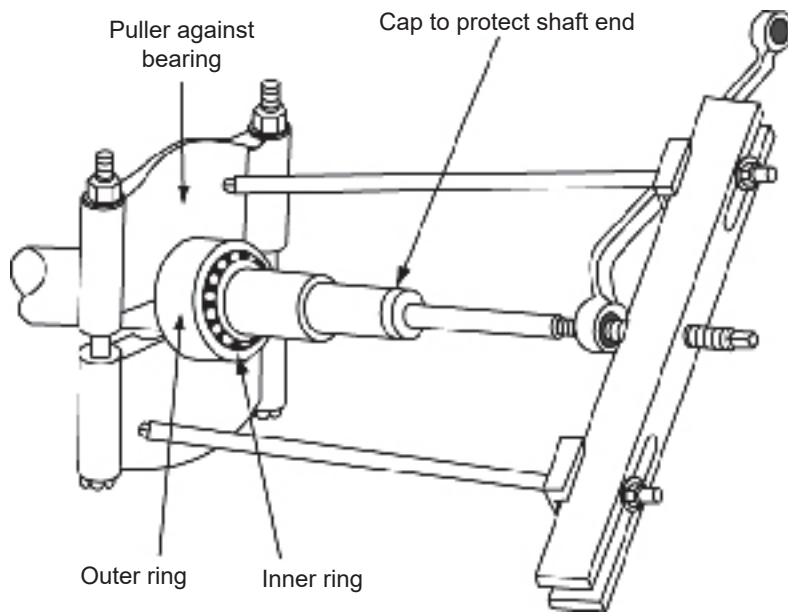
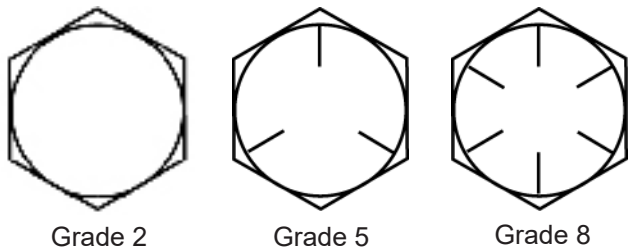

Figure 6: Removing the bearing

Installing bearings

Heat the bearing to 250° F (121° C.) in a clean, temperature-controlled circulating air oven. Using protective gloves, slide the bearing on the shaft. Be sure it remains at the correct bearing position on the shaft. Assemble the MG after the bearing has cooled.



Grade 2 Grade 5 Grade 8

ASTM & SAE grade markings

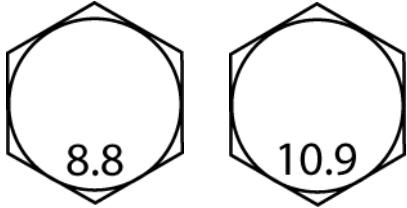

Class 8.8 Class 10.9

Metric grade markings

1-NM = 0.737 ft-lbs. = 8.85 in-lbs.

Grade 2						
Size	in-lbs.		ft-lbs		N-M	
	Min.	Max.	Min.	Max.	Min.	Max.
4-40	3.3	4.7			0.4	0.5
6-32	6.1	8.7			0.7	1.0
8-32	12.5	17.8	1.0	1.5	1.4	2.0
10-32	20.8	29.7	1.7	2.5	2.3	3.4
1/4-20	50.4	72.0	4.2	6.0	5.7	8.1
5/16-18	92.4	132.0	7.7	11.0	10.4	14.9
3/8-16	159.6	228.0	13.3	19.0	18.0	25.8
7/16-14	252.0	360.0	21.3	30.0	28.9	40.7
1/2-13	378.0	540.0	31.5	45.0	42.7	61.0
9/16-12			46.2	66.0	62.6	89.5
5/8-11			65.1	93.0	88.3	126.1
3/4-10			105.0	150.0	142.4	203.4
7/8-9			141.4	202.0	191.7	273.9

Grade 5						
Size	in-lbs.		ft-lbs		N-M	
	Min.	Max.	Min.	Max.	Min.	Max.
1/4-20	60	84	5	7	3.7	5.2
5/16-18	120	192	10	16	7.4	11.8
3/8-16	228	336	19	28	14	20.7
7/16-14	360	528	30	44	22.1	32.5
1/2-13	540	804	45	67	33.2	49.4
9/16-12	792	1152	66	96	48.7	70.8
5/8-11	1104	1608	92	134	67.9	98.8
3/4-10	2052	2724	171	227	126.1	167.4
7/8-9	3372	4368	281	364	207.2	268.5
1-8	5160	6432	430	536	317.1	395.3

Grade 8						
Size	in-lbs.		ft-lbs		N-M	
	Min.	Max.	Min.	Max.	Min.	Max.
10-32	36	49			4.1	5.5
1/4-20	72	144	6	12	8.1	16.3
5/16-18	156	276	13	23	17.6	31.2
3/8-16	324	444	27	37	36.6	50.2
7/16-14	480	720	40	60	54.2	81.3
1/2-13	780	1020	65	85	88.1	115.2
9/16-12	1140	1500	95	125	128.3	169.5
5/8-11	1560	2040	130	170	176.8	230.5
3/4-10	2760	3600	230	300	311.8	406.7
7/8-9	4320	5760	660	480	488.1	650.8
1-8	6720	8640	560	720	759.3	976.2

Class 8.8						
Size	in-lbs.		ft-lbs		N-M	
	Min.	Max.	Min.	Max.	Min.	Max.
M4	20	32	1.7	2.7	2.3	3.6
M6	65	113	5.4	9.4	7.3	12.8
M8	168	264	14	22	20	30
M10	324	516	27	43	38	58
M12	612	900	51	75	69	101
M14	960	1428	80	119	109	161
M16			126	184	170	250
M18			183	243	248	330
M20			263	341	357	463
M22			367	457	497	619
M24			465	580	631	787

Class 10.9						
Size	in-lbs.		ft-lbs		N-M	
	Min.	Max.	Min.	Max.	Min.	Max.
M4	22	36	1.8	3	2.5	4.1
M6	77	122	6.4	10.2	8.7	13.8
M8	192	288	16	24	22	32
M10	384	576	32	48	43	66
M12	672	996	56	83	77	112
M14	1080	1554	90	132	122	179
M16			140	206	190	279
M18			205	271	277	368
M20			294	381	398	517
M22			409	510	554	691
M24			531	662	720	898

Table 2: Recommended lubricated torque values. (If no lubricant is used, increase values by 25%.)

Troubleshooting Guide (corrective maintenance)

Warning: Problems left uncorrected can result in injury or serious damage, which can result in costly repairs and downtime.

Between regular preventive maintenance inspections, be alert for any signs of trouble. Correct any trouble immediately. See Table 6 for symptoms, causes and remedies.

Symptom	Cause	Remedy
Low generator voltage	Defective voltage regulator	Check the regulator, and repair or replace it if defective.
	Improper adjustment of the voltage regulator	Refer to the voltage regulator instruction manual
	Excessive load	Reduce the load. With three wire, single phase and four-wire three phase generators, the load on each leg should be as evenly balanced as possible and should not exceed current rating on any leg.
	Line loss	Increase the size of the wire.
	High resistance connections (will be warm or hot)	Make better connections.
	Shorted field	Test the field coils for a possible short by checking the resistance with an ohmmeter or resistance bridge. Return the rotor assembly to the factory for repair if the field coils are shorted.
	Weak field due to operating in hot temperature	Improve the ventilation of the generator.
	Improper voltage and/or frequency to the drive motor	Check the input voltage and the nameplate values for nominal operating values and correct.
	Excessive load	Reduce the load to rated value
Fluctuating voltage	The voltage regulator is not operating properly	Check the regulator, and repair or replace it if defective.
	Loose terminal or load connections	Make better connections
	DC excitation voltage is fluctuating	Trace the DC excitation circuit. Correct any defects
High voltage	Improper adjustment of the voltage regulator	Adjust the voltage regulator
Generator overheating	Clogged ventilating screens and air passages	Clean the screens and air passages
	Shorted or grounded generator field coils	Test the field coils for shorts. Replace the shorted rotor, or return it to the factory for repair.
Bearing overheating	Dry, worn, or contaminated bearing	Replace bearing
	Misalignment of endbrackets	Re-align endbrackets.

Symptom	Cause	Remedy
Vibration	Defective or dry bearings	Lubricate or replace the bearings.
	Rotor out of balance	Contact the factory.
	MG is not properly mounted	Check mounting and correct
	Transfer of vibration to MG from another source	Isolate the MG from the source by installing vibration dampeners between the MG base and the foundation
Motor fails to start	Improper input voltage or frequency	Check the motor nameplate rating and wiring connection drawings. Correct input power.
	Input fuses, circuit breaker or connections open	Replace or reset
	Overload devices tripped	Check for the cause of the overload, repair.
Motor drops out of synchronism (step), as indicated by a loud noise or fails to put into step	Improper setting of the motor field voltage adjust rheostat	Adjust the rheostat. Refer to the controls instructions.
	Defective voltage adjust rheostat, stationary rectifiers, diodes, field leads or exciter field coils	Check the motor field circuit. Correct any deficiencies.
	Wrong motor incoming voltage or frequency	Check the input voltage and the nameplate values for nominal operating values. Correct as needed.
Motor overheating	Overload	Measure the load and compare it with the nameplate rating, and reduce the load to the proper value.
	Operating with excessive voltage or incorrect frequency	Check the voltage drop in the distribution lines and connections. Connect the motor to a power source of correct voltage and frequency.
	Motor field voltage adjust rheostat is set wrong.	Adjust the motor field voltage adjust rheostat.
	Clogged ventilation openings	Check the flow of coolant air. Clean ventilating ports.
	Shorted stator windings	Replace the stator, or return it to the factory for repair.

Appendices

Appendix 1: List of equipment required for installation and maintenance:

Test equipment

Ammeter
Multimeter
Thermometer
Megger
Resistive Bridge

Notes

Clamp-on, 0 to 500 amp range for measuring of electrical current.
Digital, for measuring voltage, current, frequency and resistance.
For measuring temperature in Celsius
To measure insulation resistance.
To measure resistance of windings.

Special tools

Bearing puller
Exciter puller

For changing bearing.
For pulling exciter armature

Standard tools

Cable tool
Flashlight
Grease gun
Hammer
Lamp (incandescent)
Screwdrivers
Screwdrivers
Wrench
Wrench
Wrench set
Wrench set
Wrench set
Vacuum

Crimping
As required
For lubricating bearings
Soft-faced
Safety light
Standard, sized as required
Phillips, sized as required
Adjustable, 12-inch
Torque 0 to 100 ft-lb
Allen, 1/8 to 1/2 inch
Socket, 1/4 to 1 Inch with 3/8 and 1/2 inch drive
Standard, open-end/box-end combination sized 1/4 to 1 inch
Electric with nonmetallic nozzle

Materials

Air
Corrosion inhibitor
Covering material

Detergent
Gloves
Gloves
Heaters

Plastic
Rags
Water
Tags

Compressed, dry.
Nox-Rust VC #10 Oil or equivalent
Waterproof desiccant bags for protection from moisture during long-term equipment storage
As required for cleaning
Chemical-protective
Electrical-protective
Space Heater, for eliminating excess moisture in damp areas and dry out of motor or generator windings
Protection for long-term storage
As required for cleaning
Warm and clean, for cleaning
Warning and cautions

Appendix 2: Overview drawings and parts list

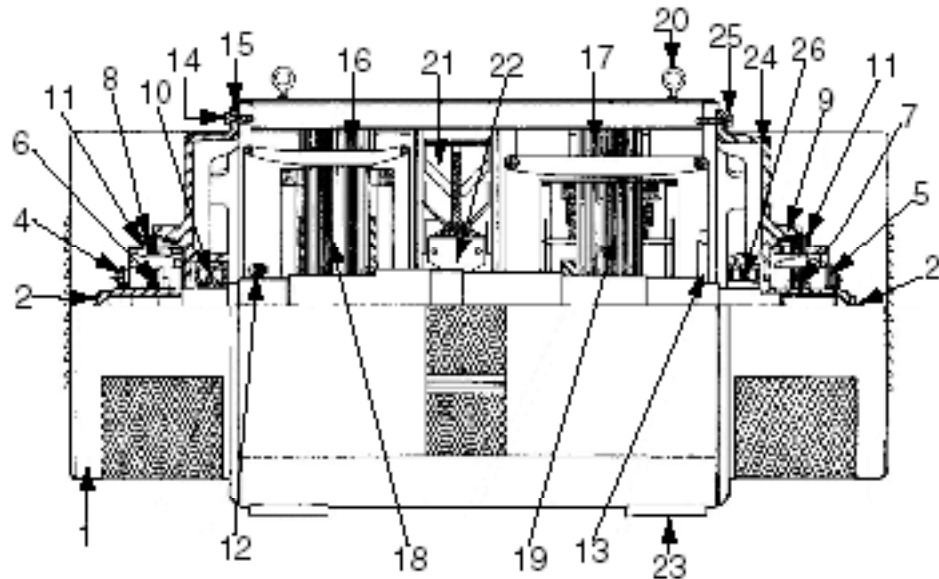

Figure 7: MG set with brushless motor, brushless revolving field AC generator and brushless motor and generator exciter; cooling fan is center mounted and unidirectional

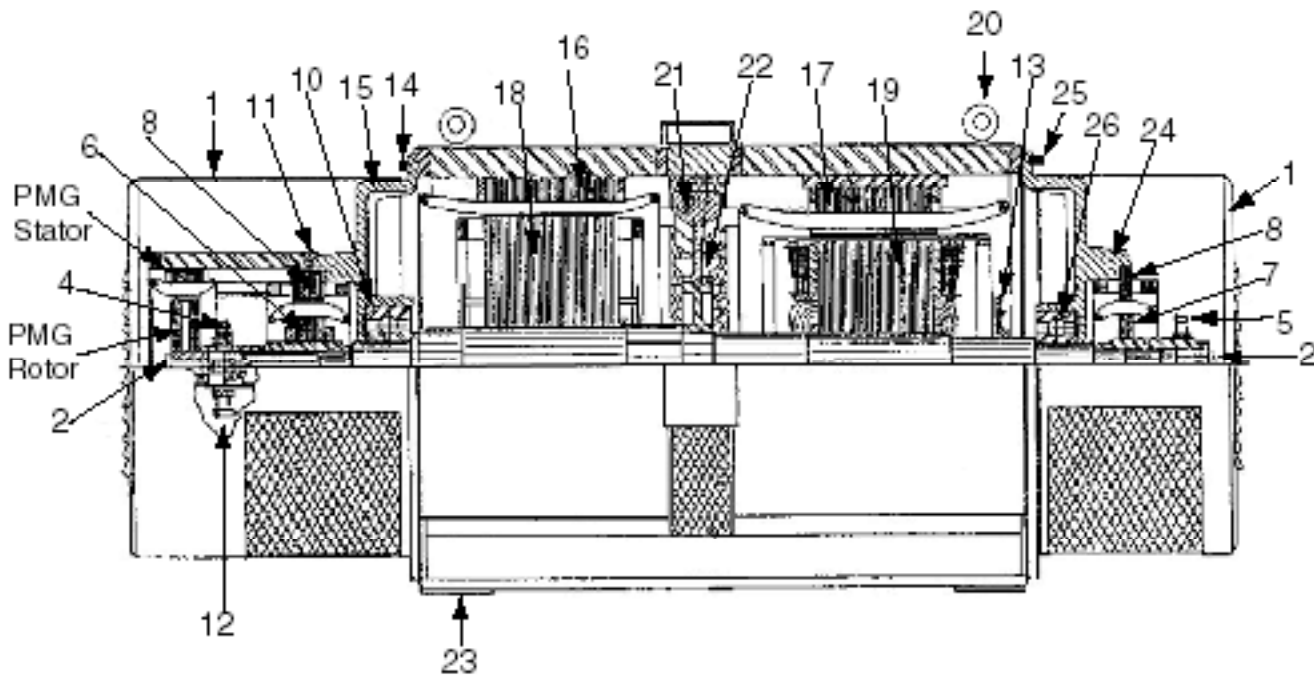

Figure 8: MG set with brushless motor, brushless revolving field AC generator and dual brushless motor and generator exciter, and permanent magnet generator (PMG)

Keyed parts list

1. Exciter cover
2. Exciter armature retaining bolt and washer.
3. Dual exciter rotating rectifier bridge
4. Rotating rectifier bridge assembly generator exciter
5. Rotating rectifier bridge assembly motor exciter
6. Exciter armature, generator exciter
7. Exciter armature, motor exciter
8. Exciter field (stator), generator exciter
9. Exciter field (stator), motor exciter
10. Bearing, generator field
11. Exciter field assembly mounting bolts
12. Surge protector, generator field (on some models, they are mounted on the rotating rectifier heat sinks)
13. Resistor, motor field (on some models it may be mounted on the end of the shaft.
14. Generator endbracket mounting bolt
15. Generator endbracket
16. Generator stator
17. Motor stator
18. Generator rotating field assembly
19. Motor rotating field assembly
20. Lifting eyebolt
21. Cooling fan
22. Fan hub
23. Mounting feet
24. Motor endbracket
25. Motor endbracket mounting bolt
26. Bearing, motor end
27. Start motor
28. Motor rotor
29. Start motor retaining bolt and washer
30. Start motor assembly cover
31. Start motor frame and stator



Kato Engineering Support

The brand you trust, the power you depend on. Include the serial number and model number for your machine in the email subject line.

Field Service

KatoService@mail.nidec.com

Parts

KatoParts@mail.nidec.com

Remanufacturing

KatoRemanufacturing@mail.nidec.com

Warranty/Quality Assurance

KatoWarranty@mail.nidec.com

Kato Engineering, Inc. | P.O. Box 8447 | Mankato, MN USA 56002-8447 | Tel: 507-625-4011
KatoEngineering@mail.nidec.com | www.KatoEngineering.com | Fax: 507-345-2798