

Instruction Manual

Installation
Operation
Maintenance

Revolving Field Alternating Current Generators
with Direct Connected Brush Type Rotating DC Exciters

Publication
INS-51C-65 (March 1981)



IDENTIFY YOUR GENERATOR BY THE FOLLOWING NUMBERS:

SERIAL NUMBER _____ **MODEL** _____ **TYPE** _____

The KATO drawings listed below are included to aid in installing, operating and maintaining your generator. Keep them with this instruction manual at all times.

Wiring Connection Drawings: _____

Parts Drawing: _____

The purpose of this manual is to provide the user of KATO REVOLVING FIELD ALTERNATING CURRENT GENERATORS with DIRECT CONNECTED BRUSH TYPE ROTATING DC EXCITERS with the information required to install, operate, and maintain the generator

Your KATO Generator is a carefully designed, rugged machine. Only components which have proven best in reliability and performance are used. Each generator has been completely tested and inspected before shipment from the KATO factory.

Treat your generator with normal care while installing, operating and maintaining the unit and it will provide many years of very good service.

TABLE OF CONTENTS

	Paragraph	Page
SECTION 1 INTRODUCTION & DESCRIPTION		
INTRODUCTION	1.1	1
GENERAL DESCRIPTION	1.2	1
CONSTRUCTION	1.3	1
SECTION 2 INSTALLATION		
RECEIVING INSPECTION	2.1	4
UNPACKING AND STORAGE	2.2	4
LOCATION	2.3	4
ASSEMBLING SINGLE BEARING GENERATOR TO ENGINE	2.4	5
SELECTION OF DRIVES FOR TWO-BEARING GENERATOR	2.5	8
BELT DRIVES - GENERAL INFORMATION	2.6	8
V - BELT	2.7	8
FLAT BELT	2.8	8
GEAR BELTS (TIMING BELTS)	2.9	8
GEAR AND FLEXIBLE COUPLINGS-GENERAL INFORMATION	2.10	9
GEAR DRIVE	2.11	10
INSTALLATION AND ALIGNMENT OF FLEXIBLE COUPLED DRIVES	2.12	10
FLYWHEEL AND TWIN DISC CLUTCH COUPLING	2.13	11
INSTALLATION OF KATO VIBRATION DAMPENERS (KATO BASE MOUNTING FEET)	2.14	11
VIBRATION	2.15	11
DOWELING	2.16	12
ELECTRICAL CONNECTIONS	2.17	12
PROTECTIVE DEVICES	2.18	12
SECTION 3 OPERATION		
PRE-OPERATION EQUIPMENT CHECK	3.1	13
INITIAL START	3.2	13
SINGLE GENERATOR OPERATING INSTRUCTIONS	3.3	13
OPERATION OF STANDBY GENERATOR	3.4	14
OPERATING INSTRUCTIONS FOR PARALLEL OPERATION OF GENERATORS	3.5	14
PHASE ROTATION	3.6	14
SYNCHRONIZING PARALLELED GENERATORS	3.7	14
DIVISION OF POWER LOAD AMONG PARALLELED GENERATORS	3.8	15
DIVISION OF REACTIVE KVA AMONG PARALLELED GENERATORS	3.9	15
SECTION 4 MAINTENANCE		
PREVENTIVE MAINTENANCE	4.1	16
CLEANING	4.2	16
WINDINGS - PROTECTION	4.3	16
INSULATION RESISTANCE TEST	4.4	16
DRYING WINDINGS	4.5	17
STATOR WINDING SHORT CIRCUIT TEST	4.6	17
MAINTENANCE OF BRUSHES, BRUSH HOLDERS, SLIPRINGS AND COMMUTATORS	4.7	17
REPLACING BRUSHES AND ADJUSTING BRUSH SPRING TENSION	4.8	18
SEATING BRUSHES	4.9	18
TURNING SLIPRINGS	4.10	18
SANDING COMMUTATOR	4.11	18
TURNING COMMUTATORS	4.12	18
UNDERCUTTING COMMUTATOR	4.13	18
BEARINGS (INCLUDING LUBRICATION INSTRUCTIONS)	4.14	19
BEARING REMOVAL	4.15	19
BEARING INSTALLATION	4.16	19
TROUBLESHOOTING	4.17	19
DISASSEMBLY OF SINGLE BEARING GENERATOR	4.18	23
DISASSEMBLY OF TWO BEARING GENERATOR	4.19	23
ORDERING RENEWAL PARTS	4.20	23
WARRANTY		26

LIST OF ILLUSTRATIONS

SECTION 1 INTRODUCTION & DESCRIPTION

	Page
FIGURE 1-1 TYPICAL "SEALED" BEARINGS & BEARING HOUSING CONSTRUCTION	2
FIGURE 1-2 TYPICAL "REGREASABLE" BEARINGS & BEARING HOUSING CONSTRUCTION	2
FIGURE 1-3 REVOLVING FIELD GENERATOR WITH DIRECT CONNECTED BRUSH TYPE EXCITER – VOLTAGE AUTOMATICALLY REGULATED BY VOLTAGE REGULATOR	3
FIGURE 1-4 REVOLVING FIELD GENERATOR WITH DIRECT CONNECTED BRUSH TYPE EXCITER – VOLTAGE INHERENTLY REGULATED	3

SECTION 2 INSTALLATION

FIGURE 2-1 BRUSH RAISED IN BRUSH HOLDER	5
FIGURE 2-2 CHECKING ENGINE FLYWHEEL RUNOUT	6
FIGURE 2-3 CHECKING ENGINE FLYWHEEL HOUSING RUNOUT	6
FIGURE 2-4 CHECKING SPACING FROM GENERATOR ADAPTER TO OUTSIDE OF DRIVE DISKS (DIM. "Y")	7
FIGURE 2-5 CHECKING SPACING FROM BOLTING SURFACE OF ENGINE FLYWHEEL HOUSING TO BOTTOM OF THE DRIVE DISK RECESS IN FLYWHEEL (DIM. "C")	7
FIGURE 2-6 TYPICAL DRIVE DISK TO FLYWHEEL INSTALLATION	8
FIGURE 2-7 CHECKING GENERATOR SHAFT RUNOUT	8
FIGURE 2-8 TESTING ANGULAR ALIGNMENT OF MOTOR AND GENERATOR SHAFTS	9
FIGURE 2-9 TESTING ANGULAR ALIGNMENT OF MOTOR AND GENERATOR SHAFTS FOLLOWING COUPLING INSTALLATION	9
FIGURE 2-10 TESTING PARALLEL ALIGNMENT OF MOTOR AND GENERATOR SHAFTS	9
FIGURE 2-11 TESTING PARALLEL ALIGNMENT OF MOTOR AND GENERATOR SHAFTS FOLLOWING COUPLING INSTALLATION	9
FIGURE 2-12 CHECKING ALIGNMENT OF TWIN DISC COUPLING	10
FIGURE 2-13 KATO BASE FOOT VIBRATION DAMPENERS	11
FIGURE 2-14 KATO VIBRATION ISOLATORS	11

SECTION 3 OPERATION

FIGURE 3-1 SYNCHRONIZING PARALLELED GENERATORS USING TEST LAMPS	14
---	----

SECTION 4 MAINTENANCE

FIGURE 4-1 BRUSH RAISED IN BRUSH HOLDER	17
FIGURE 4-2 UNDERCUT COMMUTATOR	19
FIGURE 4-3 REMOVING BEARING FROM GENERATOR SHAFT	19
FIGURE 4-4 INSTALLING BEARING ON GENERATOR SHAFT	19
FIGURE 4-5 CROSS SECTION VIEW, TYPICAL KATO REVOLVING FIELD SINGLE BEARING AC GENERATOR with DIRECT CONNECTED BRUSH TYPE DC EXCITER	24
FIGURE 4-6 CROSS SECTION VIEW, TYPICAL KATO REVOLVING FIELD TWO - BEARING AC GENERATOR with DIRECT CONNECTED BRUSH TYPE DC EXCITER	25

LIST OF TABLES

TABLE 2-1 ALLOWABLE FLYWHEEL AND DRIVE DISK RECESS RUNOUT	6
TABLE 4-1 QUARTERLY PREVENTIVE MAINTENANCE SCHEDULE	16
TABLE 4-2 TROUBLESHOOTING CHART	20

SECTION I INTRODUCTION & DESCRIPTION

1.1 INTRODUCTION

1.1.1 This manual contains instructions for installing, operating, and maintaining KATO Revolving Field Generators which are excited from a direct connected brush type rotating DC exciter. Also included are descriptions of the basic construction and general description of this series of generators. Instructions pertaining to installation, operation, and maintenance of the voltage regulator when used are included in the manual supplied by the manufacturer of the voltage regulator.

1.1.2 Electrical connection drawings for the specific model, type, and serial number of the generator are contained as supplementary information in a separate part of the generator manual. These drawings are the official source of information for making electrical connections or ordering replacement parts.

1.2 GENERAL DESCRIPTION

1.2.1 The alternating current generators described in this manual are of the revolving field type which have direct connected brush type rotary DC exciters. This manual describes generators of single or two bearing construction. Single bearing generators are designed for direct coupling to a stationary prime mover and two bearing generators are designed for gear, belt, or flexible coupling to a stationary prime mover. The generators are manufactured in many sizes and ratings.

1.2.2 Generator field excitation is supplied from a direct connected brush type rotary DC exciter. Regulation of the generator output voltage is accomplished by controlling the alternator field excitation current supplied by the exciter.

1.2.3 Control of the generator output is normally accomplished by using a variable resistor or rheostat in the DC exciter shunt field. The voltage adjust rheostat normally allows adjustment of generator output voltage from approximately 90 percent to 110 percent of the nominal output voltage rating. See figure 1-4, page 3.

1.2.4 When a voltage regulator is used, the output voltage of the generator is automatically controlled. The regulator senses changes in the generator output and varies the DC fed to the exciter field accordingly. An auto-voltage adjust rheostat or a variable transformer is usually incorporated in the voltage regulator circuitry to allow selection of any specific output voltage within the range of from about 90 percent to about 110 percent of the generator nominal output voltage rating. Cross current or voltage droop compensation circuitry for para-

llel operation of generators is available for most models of voltage regulators. See figure 1-3, page 3.

1.2.5 The generators may be supplied with various custom controls designed to provide the users power needs. Controls can be contained in separate wall mounted cubicles, in free standing control cubicles, or in a control box mounted to the generator. Mounting is dependent on the number and size of the controls or the customer's specifications.

1.2.6 All controls used on Kato Generator Sets are those which have proved, during many years of service, to be the most reliable. Should replacement of a control device be necessary, a complete line of replacement controls can be supplied by Kato Engineering Company with a minimum of "waiting" time. When generators are used as vital power units it is recommended that spare control devices such as voltage regulators be kept on hand at all times. Should a failure of these vital devices occur, install the spare and return the defective assembly to Kato Engineering Company for repair.

1.3 CONSTRUCTION

1.3.1 KATO Generators are designed by an expert power engineering staff to provide your power needs. All machines are carefully designed and constructed to ensure trouble free operation and maximum service life. The sturdy frame is fabricated of heavy steel members welded to the endbell pilot rings. A heavy steel base is welded to the frame assembly to simplify installation and alignment of the generator with the prime mover. Eyebolts installed in the frame enable the complete generator to be lifted with a conventional overhead hoist. A heavy steel wrapper cover of drip-proof construction encloses the frame assembly.

1.3.2 The generator stator core is constructed of one-piece steel laminations. The steel laminations are assembled under pressure to form the stator core. The assembled core is rigidly welded to the frame ribs. Heavily insulated stator coils of highest quality magnet copper are inserted in the stator slots. Stator core slots are lined with highest quality insulating material. The complete stator assembly is impregnated with electrical varnish and baked several times to ensure excellent bonding qualities, high dielectric strength, and maximum moisture resistance. Stator leads on most units are brought out to a convenient junction box located on the generator frame. The leads terminate in standard connection lugs or strap copper terminals for ease of connection to the load lines.

1.3.3 The generator field poles are mounted on a large diameter shaft. Field coils of heavily insulated wire are machine wound directly onto poles with insulating varnish or the new "extra strength" epoxies applied between each layer. Damper windings, consisting of heavy copper bars imbedded in the poles are standard on Kato revolving field generators. Their purpose is to keep damping current losses low and limit increase of third harmonic voltage with increase of load. The damper windings also prevent "hunting" during parallel operation of generators. The entire rotor is dipped and baked to form one complete, homogeneous mass.

1.3.4 A heavy duty rotating DC exciter is directly connected to the generator. The exciter field bolts to the generator endbell and the exciter armature slides into place on an extension of the generator shaft. The exciter armature is normally aligned and locked in place on the generator shaft by either a key or by aligning a lug on the exciter armature with a slot in the generator shaft. Final locking is accomplished by a retaining bolt and washer. Heavy duty exciter armature windings, commutator and brush rigging assure excellent performance of the exciter. The complete exciter is covered by a removable drip-proof cover.

1.3.5 Generator excitation voltage is fed from the exciter to the generator field through sliprings and brushes. Heavy duty construction of sliprings and brush rigging ensures maximum commutation and service life of the sliding contacts. Under normal operating conditions the only maintenance of the brush rigging normally required is keeping the sliprings, commutator and brushes clean, and replacing brushes when worn excessively.

1.3.6 KATO single and two bearing generators are designed with a self contained cooling system which circulates air through the machine. Ambient air is drawn into the machine through louvered openings by a large capacity blower. The warm air is exhausted through the screened opening enclosing the blower assembly.

1.3.7 Most KATO generators under 75 KW in size have "sealed" ball bearings which do not require periodic lubrication. Most KATO generators over 75 KW in size have grease fittings in the bearing housing and have bearings which should be periodically lubricated. Refer to Section 4, paragraphs 4.14 through 4.14.2.

HEAVY DUTY DOUBLE SHIELDED BALL BEARINGS

seals keep grease in - dirt and moisture out; factory lubricated and normally will not require replenishment of grease during life of bearing.

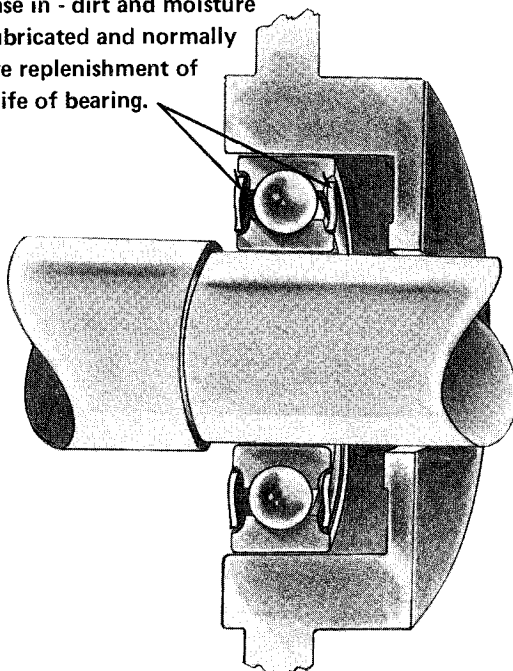

FIGURE 1-1 TYPICAL "SEALED" BEARINGS & BEARING HOUSING CONSTRUCTION.

GREASE FITTING installed at factory

BEARING SEAL keeps grease in; dirt and moisture out

GREASE RESERVOIR holds large reserve of grease

GREASE RELIEF along the shaft automatically eliminates excessive grease due to heat expansion or careless overgreasing

RELIEF VALVE additional relief of excessive grease; protects bearing seal from high grease gun pressure

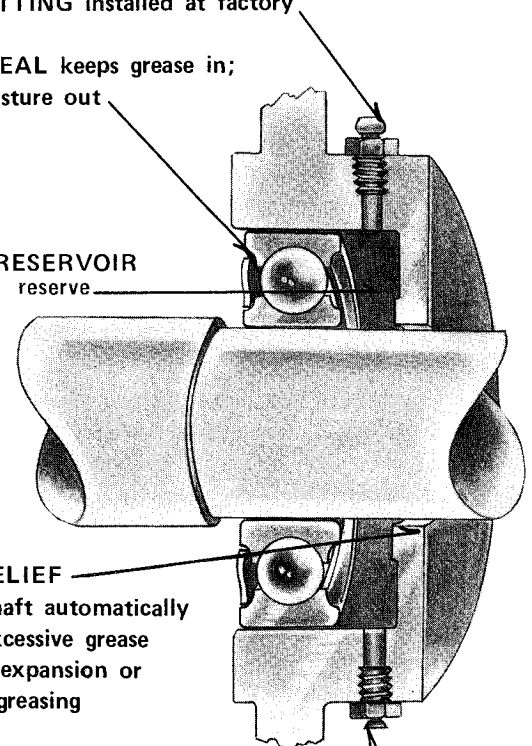

FIGURE 1-2 TYPICAL "REGREASABLE" BEARING & BEARING HOUSING CONSTRUCTION.

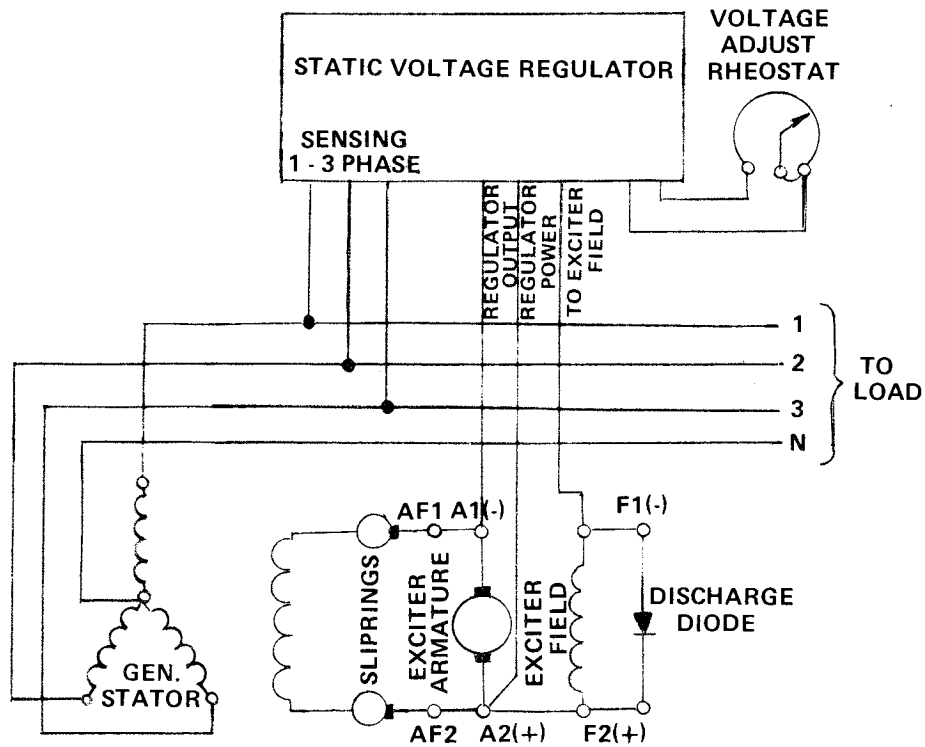

FIGURE 1-3 REVOLVING FIELD GENERATOR WITH DIRECT CONNECTED BRUSH TYPE DC EXCITER – VOLTAGE AUTOMATICALLY REGULATED BY VOLTAGE REGULATOR.

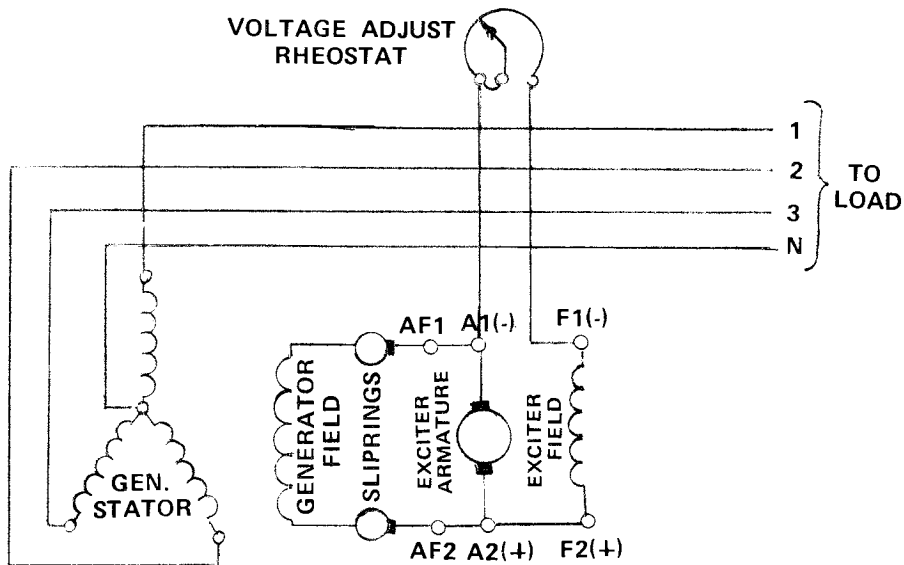

FIGURE 1-4 REVOLVING FIELD GENERATOR WITH DIRECT CONNECTED BRUSH TYPE DC EXCITER – VOLTAGE INHERENTLY REGULATED.

SECTION 2 INSTALLATION

CAUTION

2.1 RECEIVING INSPECTION

2.1.1 The generator is carefully packed and crated for shipment, and can withstand most shocks incurred during transit. Before accepting shipment from the transportation company examine the crating carefully to determine if any damage has occurred during shipment. Unpack the unit as described in paragraph 2.2 and then carefully examine the sheet metal frame cover and exciter cover for signs of damage. Remove the exciter cover and fan screen and examine the inside of the generator for signs of damage to windings, lead wires, and other internal parts. Inspect for loosely mounted components and the presence of moisture. Inspect to make certain foreign material such as crating nails, loose bolts, or packing material which may have fallen into the machine during unpacking are removed. On two-bearing machines turn the rotor by hand to make certain it rotates freely without binding. If damage is noted, determine the extent of damage and immediately notify the transportation company claims office and Kato Engineering Company. Be sure to give complete and accurate details when reporting damage.

2.1.2 If the generator is to be placed in storage repackage and crate the generator set. Recommended procedures for storage are contained in paragraph 2.2.

NOTE: Single bearing generators are usually shipped with brushes raised in brush holders to prevent damage to brushes during shipment and installation. DO NOT LOWER BRUSHES IN BRUSH HOLDERS UNTIL INSTALLATION OF GENERATOR TO ENGINE IS COMPLETE.

2.2 UNPACKING AND STORAGE

2.2.1 If the generator is received during cold weather, let the crated unit stabilize to room temperature before removing the protective crating and packing material. This precaution will minimize the condensation of moisture on coil surfaces, eliminating the possibilities of wet windings and insulating materials which could cause early malfunctions of the generator.

2.2.2 Unpack the generator with care to avoid damage to the unit. Move the generator to the mounting location by attaching an overhead hoist to the eye-bolts installed in the generator frame. Determine that the hoist, when used, is of sufficient strength to adequately support the weight of the generator. Hoist and hoist cables should have a rating of not less than 1½ times the weight of the generator.

ALWAYS MAKE CERTAIN EXTREME CARE IS TAKEN WHEN MOVING THE GENERATOR TO PREVENT ITS STRIKING OTHER OBJECTS OR PERSONNEL. NEVER APPLY A LIFTING FORCE TO STRUCTURAL POINTS OTHER THAN THOSE PROVIDED FOR THAT PURPOSE.

2.2.3 If the generator is not to be installed in its operating location as soon as received, it should be stored in a clean, dry area, not subject to sudden temperature or humidity changes. If possible, storage should be in an ambient temperature of approximately normal room temperature. Units which cannot be stored in a temperature and humidity controlled area and which are to be in storage for a period of longer than six months should be prepared for storage by installing desiccant bags under the exciter cover and inside the terminal box and vacuum sealing the unit in a covering of plastic or other material designed for that purpose. The unit should be adequately tagged to ensure that desiccant bags are removed before the unit is placed in operation.

2.3 LOCATION

2.3.1 The synchronous generator can be installed in a well ventilated area which affords sufficient accessibility for operation and maintenance of the unit and which allows a sufficient unobstructed flow of coolant air. Avoid locations which would subject the generator to excessive moisture, dust, steam or the fumes from acids, alkalines or other corrosive chemicals. If such exposure cannot be avoided, establish a rigid periodic maintenance schedule. The adverse effect of excessive moisture can usually be eliminated or at least greatly lessened by the use of space or strip heaters.

2.3.2 The foundation or supports which mount the generator and prime mover must be rigid, level and of ample size and strength to support the weight of the generator and prime mover. Although a reinforced concrete foundation usually makes the best foundation for heavy machinery, the generator and prime mover may be placed on any concrete, steel or other structural material which will adequately support the weight of the unit. Bearing loads of structural materials can be obtained by referring to engineering handbooks.

2.4 ASSEMBLING SINGLE BEARING GENERATOR TO ENGINE

2.4.1 The generator and engine should be mounted on a rigid steel base. Paragraph 2.4.2, steps (a) through (q) describe the major precautions and steps necessary to ensure satisfactory installation of the generator to the engine. They are listed in the order that the assembly work should be performed.

2.4.2 Slight differences exist between the various models and types of Kato Generators within the series described in this manual. Personnel assembling the generator to the engine must make certain that any assembly procedures necessary to completely install the generator to the engine is done, even though some of the work which must be performed when assembling the generator to the engine may not be described in the following steps.

- a. Before assembling generator to engine, remove exciter and generator covers and raise the exciter and generator brushes in their holders as shown in figure 2-1.
- b. Before assembling generator to the engine, check to make certain generator bearing end clearance is sufficient. **GENERATOR BEARING END CLEARANCE SHOULD NOT BE LESS THAN: TOTAL ENGINE CRANKSHAFT AXIAL MOVEMENT + 1/16 in.**

NOTE

Generator shipped from factory with approximately 1/8 inch bearing end clearance.

- c. Before starting to assemble the generator to the engine, mount the base of a dial indicator on the engine flywheel housing (bellhousing) and position the indicator finger on the drive disk recess of the flywheel as shown on figure 2-2. Set the dial

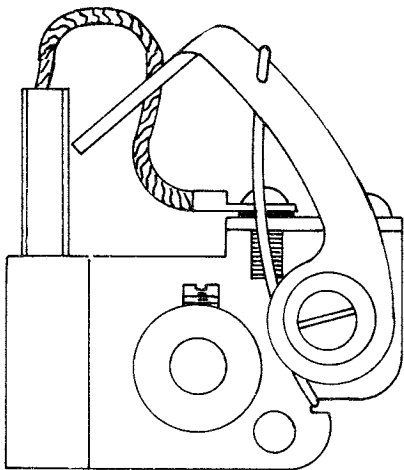

FIGURE 2-1 BRUSH RAISED IN BRUSH HOLDER.

indicator to zero. Turn the engine through one complete revolution. **TOTAL INDICATOR READING SHOULD NOT EXCEED .003-inch per EACH FOOT OF DIAMETER OF THE FLYWHEEL.** See TABLE 2-1.

If reading exceeds allowable limits excessive vibration could result. Contact the engine manufacturer for recommendations if runout exceeds suggested limits.

NOTE

The flywheel drive disk recess may have to be machined if runout is excessive. If the flywheel requires machining and it is not practical to remove the flywheel from the engine shaft, contact KATO Engineering Company, Parts and Service Department, requesting information pertaining to KATO tooling available on a rental basis, which will permit turning the flywheel without removing it from the engine.

- d. Before starting to assemble the generator to the engine, mount the base of a dial indicator on the center of the flywheel and position the finger of the indicator on the machined surface of the flywheel housing (bellhousing) which bolts to the generator adapter. See figure 2-3. Set the dial indicator to zero. Turn the engine through one complete revolution. **TOTAL INDICATOR READING SHOULD NOT EXCEED .003-INCH PER EACH FOOT OF DIAMETER OF THE FLYWHEEL HOUSING.** See TABLE 2-1. If reading exceeds the allowable limit excessive vibration could result. Contact the engine manufacturer for recommendations if runout exceeds .003-inch per foot of diameter of the flywheel housing.
- e. Before starting to assemble the generator to engine, measure the distance from the surface on the generator adapter that bolts to the engine flywheel housing (Dimension "Y", figure 2-4). Measure the distance from the machined surface on the engine flywheel housing to the bottom of the drive disk recess in the flywheel (Dimension "C", figure 2-5).

DIMENSION "C" MUST EQUAL "Y"

If the distance from the flywheel housing to drive disk recess "C" is more than the distance from the generator adapter to drive disks "Y", install additional spacers between the drive disks and the generator drive hub. If "Y" is more than "C" remove spacers located between the drive disks and generator drive hub.

- f. Make certain drive disks "seat" in the drive disk recess.

WARNING

NEVER GRIND O.D. OF DRIVE DISKS AND NEVER ATTEMPT TO "DRILL OUT" HOLES IN DRIVE DISKS. IF DRIVE DISKS DO NOT FIT PROPERLY, ORDER NEW DRIVE DISKS. INCLUDE DIMENSIONAL DATA OF FLYWHEEL.

- g. Use lock washers on all bolts used to secure generator to engine and base.
- h. If the bolts that secure the drive disks to the flywheel cannot be installed due to insufficient clearance between fan and drive disks, it may be necessary to loosen and move fan.

NOTE

If bolts that secure the drive disks to the flywheel cannot be tightened with a socket or box wrench, using 1/4 - inch to 3/8 - inch long spacers inserted on the bolts as shown in figure 2-6 will increase the clearance between the bolt heads and the flywheel.

CAUTION

IF FAN IS MOVED, MAKE CERTAIN THAT BEFORE GENERATOR SET IS PLACED IN OPERATION FAN IS POSITIONED WITH ABOUT 1/2-INCH CLEARANCE BETWEEN FAN AND BAFFLE AND ALL FAN BOLTS ARE INSTALLED AND TIGHTENED.

- i. Make certain generator mounting pads contact the base evenly and with equal pressure. Use of shims may be required.
- j. After generator is assembled to the engine; but before installing the fan screen or placing generator set in operation, check run out of the generator shaft. Check run out by placing the base of a dial indicator on a generator frame rib and positioning the indicator finger on the generator shaft as shown in figure 2-7. Set dial indicator to zero. Turn generator through at least one revolution. **TOTAL INDICATOR READING SHOULD NOT EXCEED .005 - INCH.** See NOTE on page 7.

TABLE 2-1

FLYWHEEL DRIVE DISK RECESS		
Pilot Diameter	Nominal Clutch Dia.	Allowable Run Out (Total Indicator Reading)
6½	8.500	.002
7½	9.500	.002
8	10.375	.002
10	12.375	.003
11½	13.375	.003
14	18.375	.004
16	20.375	.005
18	22.500	.005
21	26.500	.006
24	28.875	.007

FLYWHEEL HOUSING		
SAE Housing Number	Housing Inside Dia.	Allowable Run Out (Total Indicator Reading)
6	10.500	.002
5	12.375	.003
4	14.250	.003
3	16.125	.004
2	17.625	.004
1	20.125	.005
½	23.000	.005
0	25.500	.006
00	31.000	.007

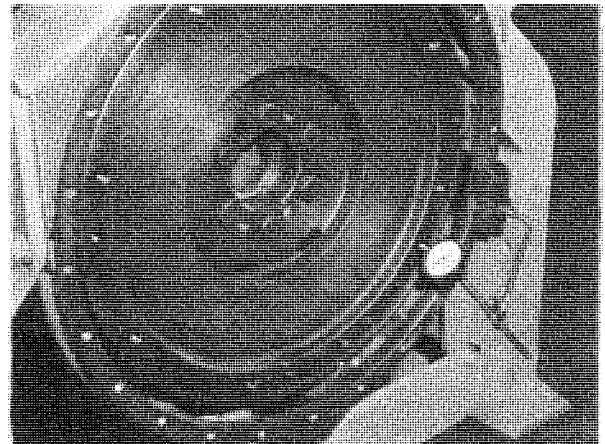

FIGURE 2-2 CHECKING ENGINE FLYWHEEL RUNOUT

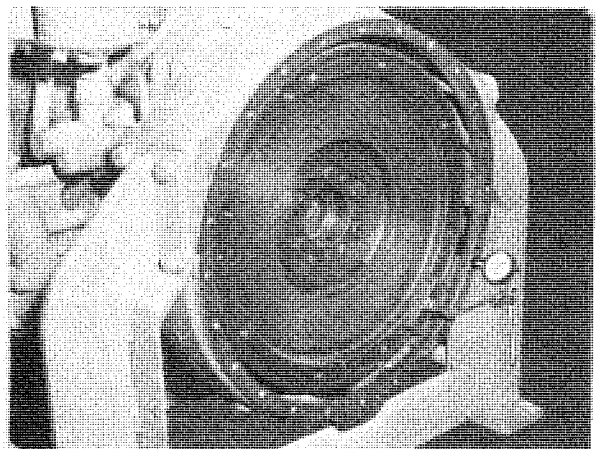

FIGURE 2-3 CHECKING ENGINE FLYWHEEL HOUSING RUNOUT

NOTE

Use inspection mirror to read indicator. It may be necessary to move fan out of the way. See CAUTION following step h.

- k. After generator is assembled to engine, but before placing the generator set in operation, go back and make certain all bolts that secure the generator to the engine and the base are tight. Check to make certain generator fan is positioned with approximately $\frac{1}{2}$ -inch clearance between fan and fan baffle and check all fan bolts to make certain they are tight.
- l. Before placing generator set in operation, visually inspect clearance between generator stationary and rotating parts.

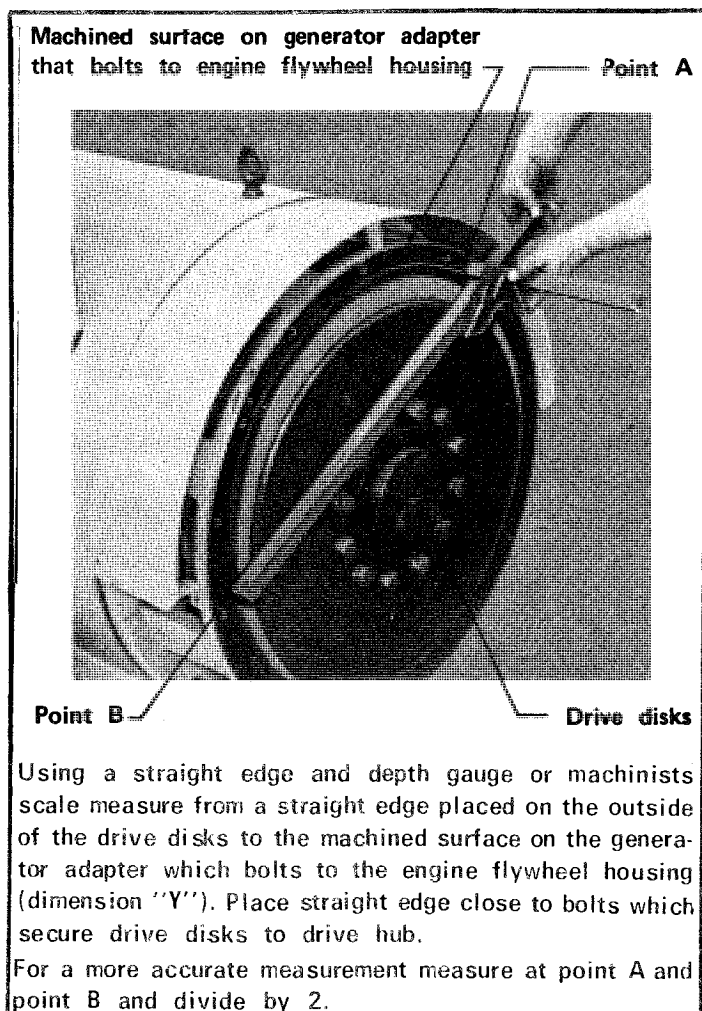

FIGURE 2-4 CHECKING SPACING FROM GENERATOR ADAPTER TO OUTSIDE OF DRIVE DISKS (DIM. "Y")

- m. If the exciter armature is not installed, slide it completely onto generator shaft and install retaining bolt and washer.

CAUTION

IF EXCITER HAS AN ALIGNING KEY MAKE CERTAIN KEY IS IN PLACE BEFORE INSTALLING EXCITER ARMATURE.

- n. Lower exciter and generator brushes in brush holders. Make certain they are seated and centered on the commutator and the collector rings (slip rings). Make certain exciter brushes and brush holders are clear of commutator riser.

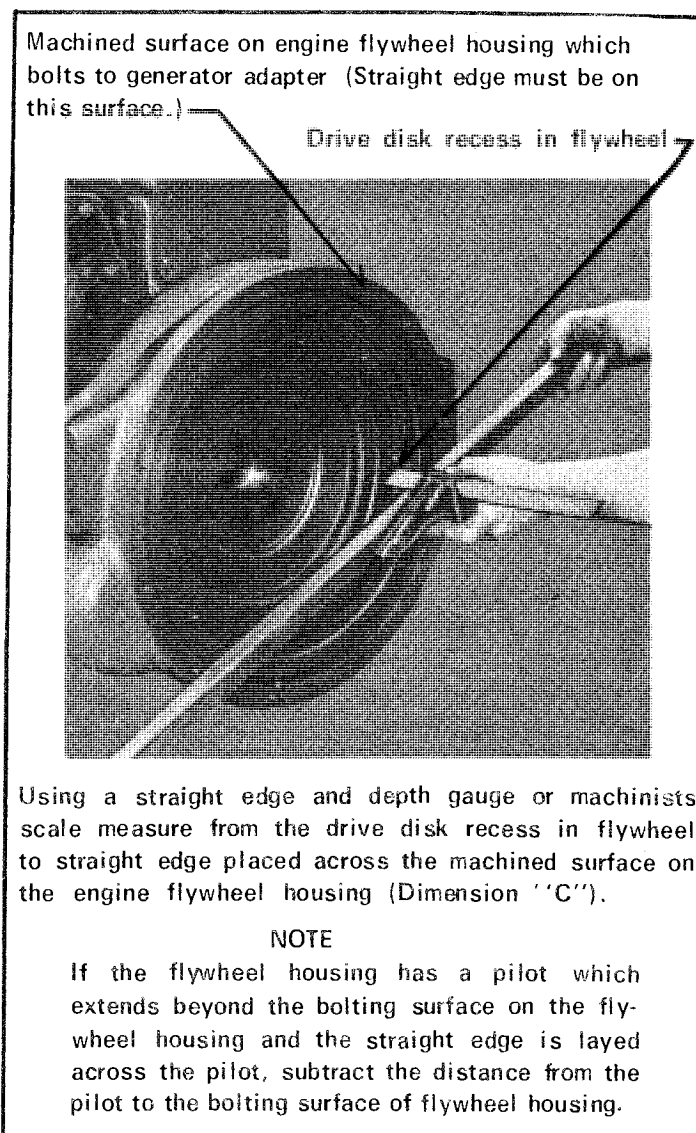

FIGURE 2-5 CHECKING SPACING FROM BOLTING SURFACE OF ENGINE FLYWHEEL HOUSING TO BOTTOM OF THE DRIVE DISK RECESS IN FLYWHEEL (DIM. "C")

- o. Before placing generator set in operation, turn engine through several revolutions, but do not permit engine to start. Visually inspect clearance between generator stationary and rotating parts. Check alignment of the exciter armature with exciter field poles. Listen for unusual noises such as produced by parts rubbing together.
- p. When assembly has been satisfactorily completed and inspected, install covers and guards.
- q. Start and stop the generator set several times. Listen for unusual noises, vibration or any other abnormal conditions. See Section 3, paragraphs 3.1 and 3.2.

2.5 SELECTION OF DRIVES FOR TWO - BEARING GENERATOR

2.5.1 Satisfactory generator operation will depend upon intelligent selection of drive couplings. In general, solid couplings are not recommended except when the generator and prime mover frames are directly connected and belt drives should not be used when belt speed exceeds 5000 feet per minute.

2.6 BELT DRIVES - GENERAL INFORMATION

2.6.1 Proper alignment and tightness of belt drives is essential. Improper alignment and belt tightness will increase belt wear as well as increase bearing

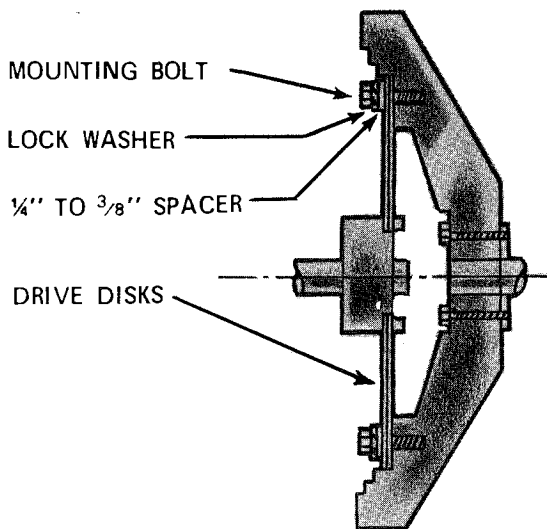

FIGURE 2-6 TYPICAL DRIVE DISK TO FLYWHEEL INSTALLATION.

loads and vibration. Select belt drive in accordance with belt manufacturer's specifications. Make certain generator and prime mover are rigidly mounted. In general belt drives are not recommended when belt speed exceeds 5000 feet per minute.

2.7 V-BELT

2.7.1 Use only matched belt sets and avoid minimum pitch sheaves and belts. Follow the V-belt manufacturer's specifications or NEMA limits for sheave pitch.

2.7.2 Make certain the shaft axis of the prime mover and generator are parallel. Belts must enter and leave sheaves with no side bending. Tighten just enough to prevent slippage at full load. Never grease or use belt dressing on belts.

2.8 FLAT BELT

2.8.1 Selection of belts and pulleys of ample width will reduce amount of tension required to prevent slippage at full load. Lower belt tension reduces bearing loads and belt wear.

2.8.2 Position the pulleys so crowns are in the same plane. Make certain motors and generator shafts are paralleled. Observe belt manufacturer's or NEMA limits for pulley sizes.

2.9 GEAR BELTS (TIMING BELTS)

2.9.1 In general, installation of gearbelts will be the same as for flat belts. The precautions listed in (a.) through (e.) on page 9 should be taken when installing a gearbelt drive.

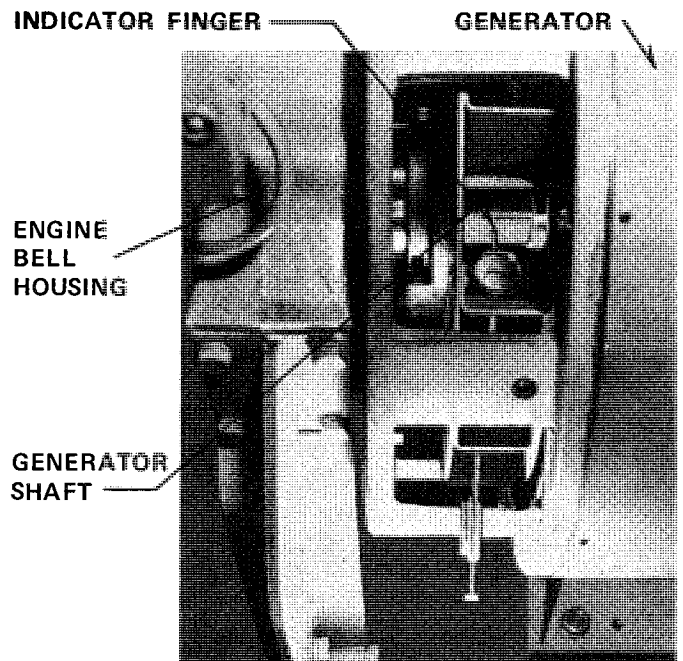

FIGURE 2-7 CHECKING GENERATOR SHAFT RUNOUT

- a. Gearbelts should be installed with snug fit, neither too tight or too loose. High initial tension is not necessary but when torque is unusually high a loose belt may "jump grooves". If the belt "jumps the grooves" the tension should be increased gradually until satisfactory operation is attained.
- b. Be sure that shafts are parallel and pulleys are in alignment. On a long center drive, because of the tendency of the belt to run against one flange, it is sometimes advisable to offset the driven pulley to compensate.
- c. On a long center drive, it is imperative that belt sag is not enough to permit teeth in the slack side to engage the teeth at the tight side.
- d. It is important that both prime mover and generator are mounted rigidly to prevent variation in belt tension.

- e. Although belt tension requires little attention after initial installation, provision should be made for some center distance adjustment for ease in installing and removing belt. Do not force belt over flange of pulley.

2.10 GEAR AND FLEXIBLE COUPLINGS GENERAL INFORMATION

2.10.1 When these drives are used instead of belt drives, the prime mover and generator shafts must be carefully aligned. The motor and generator must be firmly mounted to a rigid base to prevent misalignment of the unit shafts during operation. Excessive misalignment could cause vibration, noisy operation; excessive coupling or gear wear or premature bearing failure. Procedures for aligning gear and flexible couplings are contained on the following page.

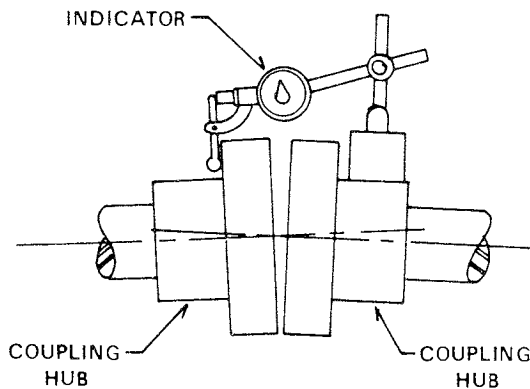

FIGURE 2-8 TESTING ANGULAR ALIGNMENT OF MOTOR AND GENERATOR SHAFTS

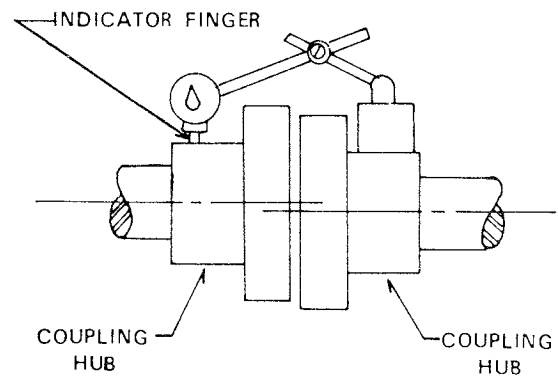

FIGURE 2-10 TESTING PARALLEL ALIGNMENT OF MOTOR AND GENERATOR SHAFTS

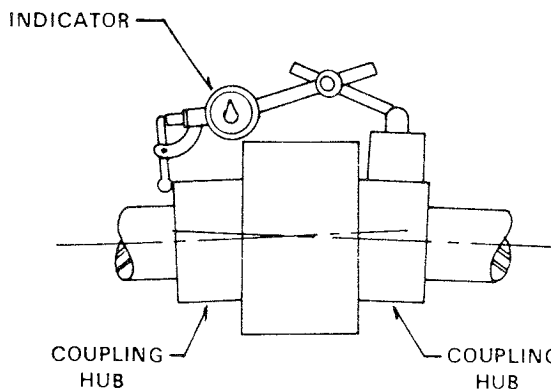

FIGURE 2-9 TESTING ANGULAR ALIGNMENT OF MOTOR AND GENERATOR SHAFTS FOLLOWING COUPLING INSTALLATION

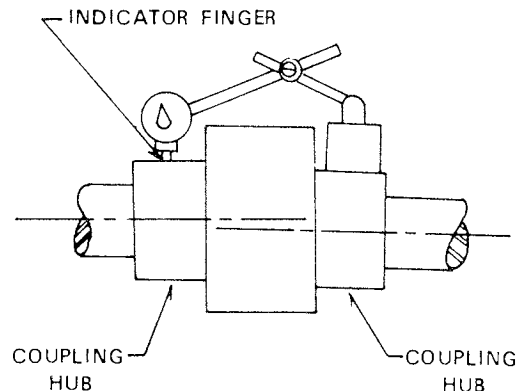

FIGURE 2-11 TESTING PARALLEL ALIGNMENT OF MOTOR AND GENERATOR SHAFTS FOLLOWING COUPLING INSTALLATION

2.11 GEAR DRIVE

2.11.1 Accurate alignment and rigid mounting are essential for satisfactory operation with gear drives. Pitch diameter and width should not be outside recommended NEMA limits. Avoid coupling which will impose excessive thrust on bearings.

2.11.2 In all cases, gear teeth must be centered with each other. Gear faces must be parallel and correct shaft center distance maintained. Gear teeth must fully engage to a depth giving approximately .002 inch maximum backlash. Avoid engagement of teeth so deep that they will bind or deflect.

2.11.3 Test for proper alignment by rotating shafts by hand. Check for backlash through at least one revolution of the shafts. Check backlash and gear face parallelism after tightening mounting bolts. Install or remove shims from under mounting feet to bring gear faces parallel.

2.12 INSTALLATION AND ALIGNMENT OF FLEXIBLE COUPLED DRIVES

2.12.1 The procedures outlined are for aligning flexible coupled drives. Follow the tolerances specified by the coupling manufacturer when less than described in this manual.

2.12.2 Install coupling hubs on generator and drive shafts in accordance with the installation procedures supplied by the manufacturer of the coupling. Then check for angular misalignment by scribing a reference mark on the coupling hub at the button or finger of the indicator to mark its position on the hub. Rotate both shafts simultaneously, keeping the finger or button of the indicator at the reference marks on the coupling hub. Note the reading on the indicator dial at each one-quarter revolution. Refer to figure 2-8 for test setup.

ANGULAR MISALIGNMENT OF THE SHAFTS MUST NOT EXCEED .001 INCH FOR EACH INCH OF RADIUS OF THE COUPLING HUB, TOTAL INDICATOR READING.

2.12.3 If angular misalignment is excessive, loosen motor and generator mounting bolts and place slotted shims under motor and generator mounting pads, as necessary, to correct alignment. Re-check alignment. Install or remove shims from under the mounting pads until aligned.

NOTE: If the motor generator set is moved to a new

location, make test setup with coupling installed as shown in figure 2-9 and then rotate shafts and check alignment as described in paragraph 2.12.2.

2.12.4 Check for parallel shaft (run-out) alignment by scribing a reference mark on the ground or machine diameter of the coupling hub at the finger or button of the indicator. Rotate both shafts simultaneously, keeping the button or finger of the indicator at the reference mark on the hub. Note the reading on the indicator dial at each one-quarter revolution. Refer to figure 2-10 for test setup.

TOTAL RUN-OUT BETWEEN HUBS SHOULD NOT EXCEED .002 OF AN INCH.

2.12.5 When run-out between hubs is excessive, install or remove shims from under each of the motor or generator mounting pads; then re-check alignment. Add or remove shims until shafts are parallel. Tighten motor and generator mounting bolts following angular and run-out alignment. Check base mounting bolts for tightness. Re-check alignment before installing coupling.

NOTE: If the motor generator set is moved to a new location check for parallel alignment by making test setup as shown in figure 2-11 and then rotate shafts and check alignment as described in paragraph 2.12.4.

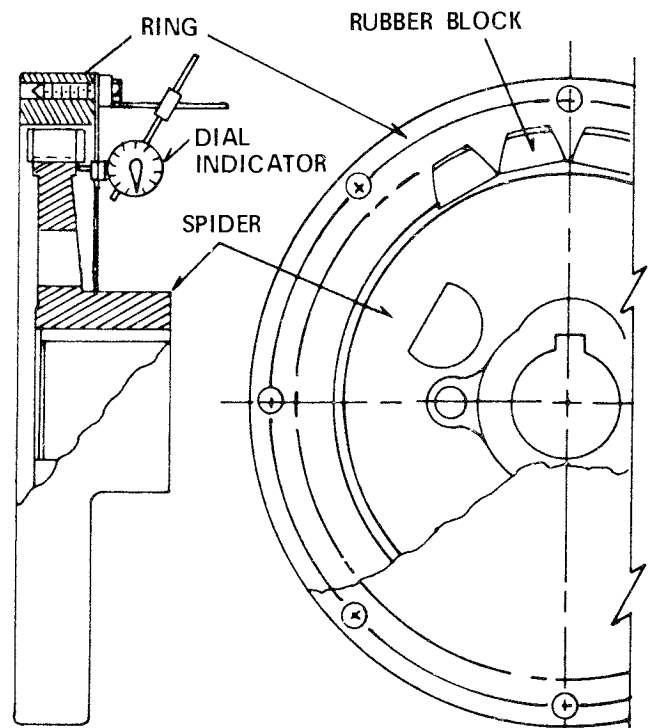

FIGURE 2-12 CHECKING ALIGNMENT OF TWIN DISC COUPLING.

2.13 FLYWHEEL AND TWIN DISC CLUTCH COUPLING

2.13.1 A flywheel and twin disc clutch coupling provide a satisfactory coupling for motor generator sets operating with shaft speeds not in excess of 3760 RPM. The coupling should be parallel between the spider and the rings. Align within .03 inch total indicator reading between spider and ring by installing or removing shims, as necessary, from under motor or generator mounting pads. See figure 2-12.

2.14 INSTALLATION OF KATO VIBRATION DAMPENERS (KATO BASE MOUNTING FEET)

2.14.1 When motors or motor generator sets are installed in areas such as office buildings where noise or vibration would be a nuisance, these undesirable effects can usually be eliminated or greatly reduced by installing vibration dampeners.

2.14.2 KATO base mounting feet when properly installed provide a means of easily leveling generator sets as well as providing "vibration dampening". Install KATO base mounting feet as shown on figures 2-13 and 2-14.

Level unit by loosening Base Foot mounting bolts and then sliding base foot in elongated slots.

Anchor to foundation with anchor bolt. Use KATO "VIBRATION ISOLATORS" to provide vibration isolation.

DO NOT TIGHTEN ANCHOR BOLT NUTS TO TIGHTLY. COMPRESSION OF VIBRATION ISOLATOR AND NEOPRENE PAD WILL ELIMINATE THEIR EFFECTIVENESS.

2.15 VIBRATION

2.15.1 After alignment of motor generator set has been completed, run unit at no load and check for excessive vibration (see operation instructions, section 3). If vibration is excessive loosen one motor mounting bolt slightly and if vibration decreases, add shims until retightening of bolt reduces or eliminates vibration. Repeat in turn for all motor mounting bolts.

2.15.2 When vibration and alignment of motor are within limits, run motor generator set at low load and check again for vibration. If excessive, add shims under generator mounting pads in same manner as for the motor. Re-check alignment after any change in shims to control vibration.

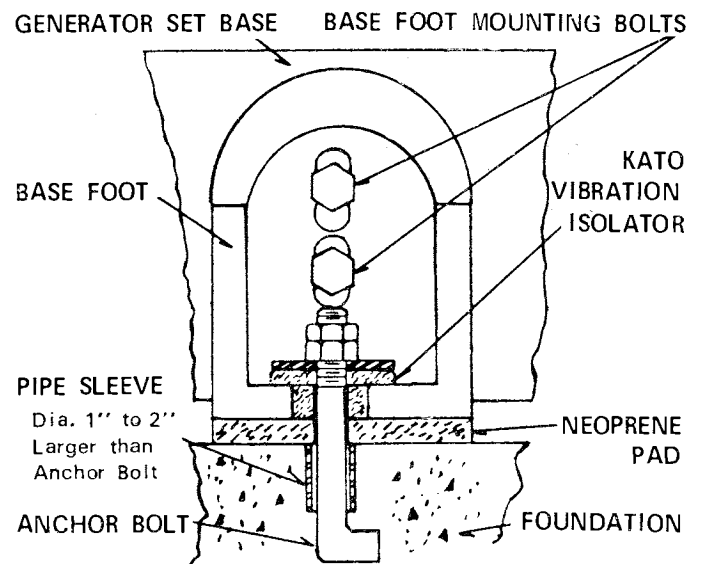
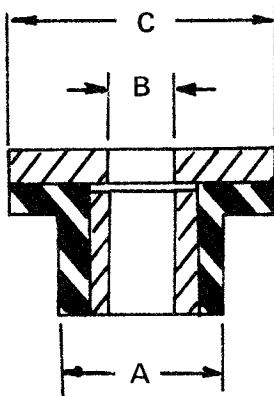

FIGURE 2-13 KATO BASE FOOT VIBRATION DAMPENERS.



Part Number	A	B	C
158-00007-01 For 3/8" mtg. bolt Base Foot hole 1-1/32"	1-1/32"	.385	1-3/4"
158-00008-01 For 1/2" mtg. bolt Base Foot hole 1-7/32"	1-7/32"	33/64"	2"
158-00009-01 For 3/4" mtg. bolt Base Foot hole 1-1/2"	1-1/2"	49/64	3"

FIGURE 2-14 KATO VIBRATION ISOLATORS

2.16 DOWELING

2.16.1 Doweling generator sets will prevent movement of the units during operation should the mounting bolts loosen slightly. Install dowels as follows:

- a. Check the alignment after the generator set has been in operation about 40 hours. Correct alignment if not satisfactory (refer to preceding paragraphs).
- b. Through opposite generator pads drill holes through and into the base. Holes should have a diameter slightly smaller than the dowel pin.
- c. Ream the holes to the proper diameter for the pins, clean out chips and then install pins.
- d. Repeat procedure for doweling of motor.

NOTE: Dowel prime movers (engine or motor) manufactured by others than Kato Engineering Company in accordance with the instructions supplied by the manufacturer of the prime mover.

2.17 ELECTRICAL CONNECTIONS

2.17.1 Before connecting the generator to the electrical power load, check nameplate for the electrical characteristics and connect the generator exactly as shown in the connection diagrams. Refer to National Electrical Code and applicable local regulations for minimum specifications for wire size, conduit and protective devices.

2.18 PROTECTIVE DEVICES

2.18.1 Engine driven sets must be protected with adequate engine governors and protected against excessive overspeed. Refer to National Electrical Code and local electrical codes for minimum electrical requirements for the generator set.

2.18.2 The output to the load of the generator should always be protected with an overload protection device such as a circuit breaker or fuses. Size fuses and circuit breakers in accordance with National Electrical and Local Codes.

SECTION 3 OPERATION

3.1 PRE-OPERATION EQUIPMENT CHECK

3.1.1 After the generator and control equipment is completely installed and wired, but before operating the unit for the first time, perform a check of the equipment as follows:

- a. If the generator windings have become wet, test winding insulation resistance and dry out windings before placing the unit in operation. Refer to the procedures for testing winding insulation resistance and the procedures for drying windings contained in Section 4 of this manual. Generators being placed in operation after being subjected to very low temperatures should be slowly warmed to prevent condensation.
- b. See paragraph 4.14. If unit has bearings which require lubrication, grease bearings.
- c. Check all interconnecting wiring against the connection diagrams supplied with the generator set.
- d. Make certain brushes are seated and centered on the generator sliprings.
- e. Inspect to see that satisfactory clearance exists between generator rotating and stationary parts. On two bearing generators rotate shaft by hand to make certain it turns freely.
- f. Make certain no foreign objects are lodged in the generator. Remove all tools and shop cloth from the vicinity of the equipment.

3.2 INITIAL START

3.2.1 After installation is complete and the checks listed in paragraph 3.1 have been completed make an initial start and operational checkout of the equipment as listed in the following general instructions:

- a. Open the OUTPUT CIRCUIT BREAKER to disconnect the generator from the load.
- b. Adjust excitation controls to supply minimum excitation to the generator field. (Normally, adjustment of field rheostats should be to full resistance - full counterclock-wise position or if variable transformer is used transformer should be adjusted to minimum voltage position).
- c. Start the generator set in accordance with the prime mover manufacturer's specifications.

- d. Stop generator set. Check rotation as unit slows to stop. On motor driven generator sets, if rotation is not correct, reverse incoming power leads. On three phase motors, reverse any two incoming lines (except the neutral line).
- e. Start and stop generator set several times. Observe any unusual conditions such as excessive noise or vibration. Allow sufficient time between starts for cooling.
- f. When operation is satisfactory to this point, adjust voltage adjust rheostat (normally to approximately the midpoint position). Start generator and bring up to rated speed. Turn voltage adjust rheostat to point where desired output voltage is obtained.
- g. Close output circuit breaker and apply a light load. Adjust voltage adjust rheostat until desired output voltage is obtained.
- h. Slowly increase load to rated power factor full load. Adjust rheostat as necessary to obtain desired output voltage.
- i. When an automatic voltage regulator is incorporated, check voltage regulation by applying the rated power factor load, and then checking the generator terminal voltage. Check voltage regulation. Refer to regulator manufacturer's operating instructions.
- j. During operation, observe the generator at regular intervals so that any abnormal conditions can be corrected before serious damage occurs.
- k. Check current on each line. Use a clip-on ammeter if an ammeter is not incorporated in generator set.
- l. Check line-to-line and line-to-neutral voltages.
- m. Shut down unit in accordance with the operating instructions supplied by the manufacturer of the prime mover.

3.3 SINGLE GENERATOR OPERATING INSTRUCTIONS

3.3.1 If the generator windings have become wet, test winding insulation resistance and dry out windings before operating the generator set. Refer to the procedures for testing winding insulation and the procedures for drying windings contained in Section 4 of this manual. Operate generator as described in paragraph 3.3.2.

3.3.2 Start and operate the generator set in accordance with the following general instructions:

- a. When voltage adjust rheostats have been previously adjusted to provide the desired output voltage, no adjustment should be required before placing the generator set in operation.
- b. Start the generator set in accordance with the operating instructions supplied by the manufacturer of the prime mover. Bring up to rated speed.
- c. Turn voltage adjust rheostat to point where desired generator output voltage is indicated on voltmeter. Apply load. Check output voltage, if not of desired value re-adjust the voltage adjust rheostat or, if used, variable transformer.
- d. When an automatic voltage regulator is incorporated in the generator set, check voltage regulation.
- e. During operation, observe the generator at regular intervals so that any abnormal conditions can be discovered and corrected.
- f. When the generator set is operated as a standby unit open the OUTPUT CIRCUIT BREAKER before shutdown of the generator set.
- g. Stop the generator in accordance with the instructions supplied by the manufacturer of the prime mover.

3.4 OPERATION OF STANDBY GENERATOR

3.4.1 Make certain OUTPUT CIRCUIT BREAKER of the primary power source is open before starting the STANDBY UNIT. Operate the generator set as described in paragraph 3.3. Following shutdown of the STANDBY UNIT, make certain OUTPUT CIRCUIT BREAKER is actuated to the OPEN position.

3.5 OPERATING INSTRUCTIONS FOR PARALLEL OPERATION OF GENERATORS

3.5.1 When operating two or more generators connected in parallel, open output circuit breaker and start each generator as described in steps (a) through (e) of paragraph 3.3.2. Make certain that the output voltage of each machine is properly adjusted to the system bus voltage.

CAUTION

DO NOT CLOSE THE LOAD CIRCUIT BREAKERS UNTIL THE GENERATORS HAVE BEEN CHECKED FOR PROPER PHASE ROTATION AND ADJUSTED FOR SYNCHRONIZATION AS DETAILED IN THE FOLLOWING PARAGRAPHS.

3.6 PHASE ROTATION

3.6.1 Before placing two or more three-phase generators in parallel, make certain the generators have the same phase rotation. This can be accomplished by connecting a three phase induction motor to each of the generators and checking the rotation of the motor. Care must be taken to make certain motor terminals are connected to the corresponding generator or bus terminals for each test. Phase rotation will be the same if the motor rotates in the same direction when connected to each generator.

3.6.2 If the motor rotates in the wrong direction when connected to one of the generators, reverse any two of the three generator leads (except neutral when used). Recheck motor rotation and continue checks until the induction motor rotates in the correct direction.

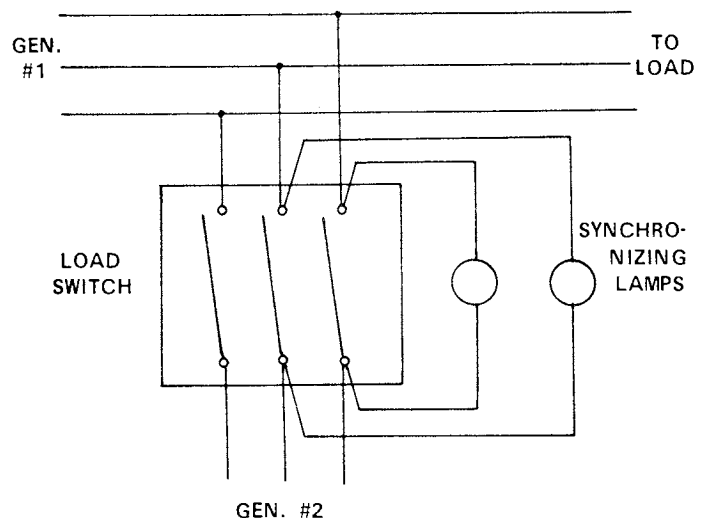

FIGURE 3-1. SYNCHRONIZING PARALLELED GENERATORS USING TEST LAMPS

WARNING

EXERCISE EXTREME CAUTION WHEN USING THIS METHOD OF SYNCHRONIZING GENERATORS TO AVOID EXPOSURE TO DANGEROUS VOLTAGES.

3.7 SYNCHRONIZING PARALLELED GENERATORS

3.7.1 Do not attempt to parallel generators until each machine to be paralleled has been checked for proper phase rotation and that each generator is adjusted for the required system voltage with the line switch open.

3.7.2 If a synchroscope is not available, generators can be synchronized by using incandescent lamps connected in the load circuit as shown in figure 3-1. Make certain that the total voltage rating of the series lamps equals the voltage rating of the generator.

3.7.3 Synchronize the generators by varying the speed of the incoming generator until fluctuation of the lamps is very slow. When the lamps are dark close the line switch. Care must be taken to close the line switch at the instant the lamps are dark.

3.8 DIVISION OF POWER LOAD AMONG PARALLELED GENERATORS

3.8.1 Adjust the engine governors in accordance with the engine manufacturer's instructions. Division of kilowatt or actual power load among generators operating in parallel is practically independent of generator excitation. Do not attempt to vary the amount of kilowatt load among paralleled generators by making adjustments to the voltage regulator.

3.9 DIVISION OF REACTIVE KVA AMONG PARALLELED GENERATORS

3.9.1 Division of reactive KVA among paralleled generators depends upon generator excitation. Methods of correcting the excitation of individual generators, should they take more or less than their share of the reactive KVA, are the addition of cross-current compensation or voltage-droop controls to the voltage regulator circuit.

3.9.2 The cross current or voltage droop rheostat should usually be set so that there is just enough resistance in the circuit to give stable operation of the generators under reactive KVA load conditions.

3.9.3 Place generator in operation, apply lagging power factor load, and check voltage droop. Maximum voltage droop from no load to full load is obtained with full voltage-droop resistance. A droop of 4% is frequently employed. Adjust each generator to be paralleled for identical droop characteristics.

3.9.4 Bring all generators up to correct speed and adjust all output voltages to identical values. Synchronize and parallel generators. Load the paralleled generators and check for satisfactory division of load currents. Correct by adjusting voltage-adjust rheostats and the droop-control resistors.

SECTION 4 MAINTENANCE

4.1 PREVENTIVE MAINTENANCE

4.1.1 Preventive maintenance is the practice of inspecting the generator set, cleaning the generator set, and eliminating minor disorders before they become serious. A routine regular preventive maintenance program practiced conscientiously will ensure peak performance, lengthen the life of the generator, and eliminate or at least greatly reduce breakdown time.

4.1.2 The quarterly preventive maintenance schedule described in TABLE 4-1 is enclosed as a guide for establishing a preventive maintenance program for generators operating under standard conditions. The specific operating conditions should be analyzed by the user of the equipment and a preventive maintenance program established accordingly. When preventive maintenance inspection determines cleaning is necessary, clean the generator and controls as described in paragraph 4.2.1.

4.2 CLEANING

4.2.1 When inspection determines cleaning is necessary, clean the generator and controls as follows:

- a. Wipe loose dirt from exterior painted surfaces of generator and, when incorporated, the generator control panel assembly (controller) with a clean lint free cloth. Remove stubborn accumulations of dirt with an approved detergent or solvent. Clean all ventilating ports with a vacuum cleaner or filtered compressed air at a pressure of from 25 to 40 psi.

WARNING

OBSERVE PRECAUTIONS SPECIFIED BY THE MANUFACTURER OF THE SOLVENT BEING USED.

- b. Clean inside of generator with a vacuum cleaner or use dry filtered compressed air at a pressure of from 25 to 40 psi. Remove stubborn accumulations of dirt and grease from windings with naphtha.

WARNING

EXERCISE EXTREME CARE WHEN USING NAPHTHA. USE ONLY IN WELL VENTILATED AREAS, AWAY FROM FLAME AND SPARKS .

- c. Clean electrical contacts such as relay contacts, switch contacts, and terminals with an approved contact cleaner. **DO NOT FILE CONTACTS.**

- d. Clean brushes and brushholders with lint free cloth. See paragraph 4.7, "Maintenance of Brushes, Brush Holders, and Sliprings".

TABLE 4-1

QUARTERLY PREVENTIVE MAINTENANCE SCHEDULE
1. If generator has bearings which require lubrication (grease fittings on generator), lubricate bearings at intervals and amounts shown on lubrication plate attached to generator.
2. Inspect lead wires and control device wiring for cracked insulation and loose terminals.
3. Inspect control equipment for loose mounting hardware.
4. Inspect control devices for accumulation of dust, moisture and other foreign matter.
5. Clean the outside of the generator assembly and ventilating screens. When dust or moisture is excessive, clean and/or dry the inside of the generator assembly.
6. Inspect brushes, brush holders, sliprings and commutator for satisfactory condition.
7. With unit running, check control devices and meters for correct adjustment and operation.
8. With unit running, observe any unusual noise or vibration. Refer to trouble shooting chart for possible causes of noise and vibration.

4.3 WINDINGS - PROTECTION

4.3.1 Generators operating intermittently in very damp locations should be protected with space heaters. Generators being placed in operation after being subjected to very low temperatures should be slowly warmed to prevent excessive condensation. Winding resistance should be checked before placing the generator in operation if the unit was subjected to an extremely damp environment.

4.4 INSULATION RESISTANCE TEST

4.4.1 A hand cranked megger of not over 500 volts is a convenient and safe method of testing insulation resistance. The formula contained on the following page is an accepted standard for measuring insulation resistance of stator windings.

Winding insulation resistance measured at 500 VDC after one minute should not be less than:

$$\text{Resistance in megohms} = \frac{\text{Rated Voltage of Machine} + 1000}{1000}$$

The above formula is satisfactory for most checks. For more information see "Recommended Practice for Insulation Resistance Testing AC Rotating Machinery", AIEE Standard No. 43.

4.5 DRYING WINDINGS

4.5.1 If the insulation fails to meet the test standards, the generator may be dried out by heat from a warm air oven, heat lamps, or strip heaters. The temperature should not exceed 75 °C. (167 °F.) Another method which can usually be used to dry windings is by application of internal heat as described in paragraph 4.5.2.

WARNING

WHEN OVEN DRYING, USE A FORCED AIR CIRCULATION OVEN, NOT A RADIANT TYPE. RADIANT TYPE OVEN WOULD OVERHEAT SOME GENERATOR PARTS BEFORE REMOTE PARTS REACHED A SATISFACTORY TEMPERATURE.

4.5.2 Drying the generator winding insulation by the application of internal heat consists of operating the generator as described in the following procedure.

- Check for excessive accumulation (pockets) of water on windings. Dry as much as possible with compressed air before applying internal heat.
- In one of the stator leads, insert an ammeter of sufficient range to read full-load generator current.
- Connect all stator lead terminals together to short circuit the stator windings.
- If a voltage regulator is incorporated, disconnect the regulator incoming and output leads and connect a variable source of DC power to the exciter field leads.

CAUTION

USE A VARIABLE RESISTOR OR RHEOSTAT IN THE INPUT CIRCUIT TO THE EXCITER FIELD TO LIMIT GENERATOR CURRENT TO EQUAL TO OR LESS THAN RATED VALUE.

- Operate the generator at normal speed. Supply just enough excitation to cause rated current to flow in the generator stator windings.

- Operate for sufficient time to ensure thorough drying of the windings. This can be determined by stopping the generator periodically and checking the insulation resistance of the windings. Insulation resistance checks at one-hour intervals are suggested. Terminate the drying-out process when measured resistance is within test standards (paragraph 4.4) and shows little change over a two to four hour period of operation.

4.6 STATOR WINDING SHORT CIRCUIT TEST

4.6.1 Use an inside-type growler and test each coil in the stator. Position the growler in the stator and hold a thin metal strip, similar to a hacksaw blade, parallel to the core slots. Energize the growler and explore the core surfaces approximately 1 pole distance on each side of the growler. Continue testing 1 core slot at a time until all coils are tested. If the winding is shorted, the metal strip will vibrate when held over the slot containing the faulty coil.

4.7 MAINTENANCE OF BRUSHES, BRUSH HOLDERS, SLIPRINGS AND COMMUTATORS

4.7.1 Brushes, brush holders, sliprings and commutators should be inspected and cleaned periodically.

4.7.2 Dirty brush holders, commutators, sliprings and brushes or brushes which are not properly "seated", or pitted sliprings will cause excessive brush sparking and poor commutation. Brushes can be raised in their holders for inspection or sanding of the sliprings or commutator as shown in figure 4-1.

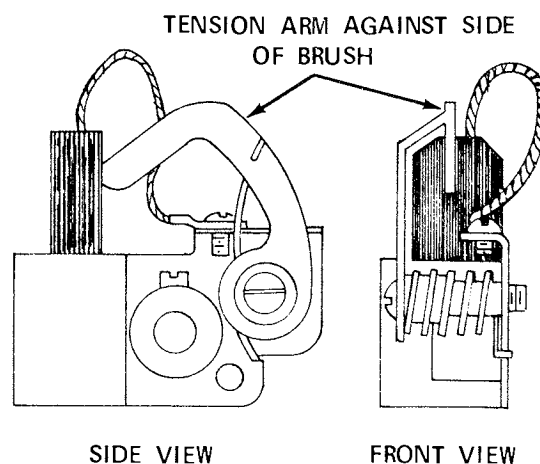

FIGURE 4-1 BRUSH RAISED IN BRUSH HOLDER.

4.8 REPLACING BRUSHES AND ADJUSTING BRUSH SPRING TENSION

4.8.1 Replace brushes when worn excessively. Make certain brush is replaced before tension arm rests on brush holder. When replacing brushes, it is most important that they are properly "seated" to the contour of the sliprings and free to move in the brush holders.

NOTE: Always order replacement brushes of the same size and of an equivalent grade or type as were installed at the factory. Order by part number including the type and serial number of the generator.

4.8.2 Nominal spring tension should be approximately 3 lbs./sq. in. of brush surface. Spring pressure within a range of from 2½ to 4 lbs./sq. in. of brush surface is normally acceptable.

4.9 SEATING BRUSHES

4.9.1 To properly seat brushes, lift all the brushes in their holders. Insert a strip of (No. 00) sandpaper between the brush and the slipring or commutator with the abrasive side toward the brush. Lower one of the brushes in the holder. With the brush in the holder and under pressure draw the sandpaper in the direction of rotation of the generator, keeping the sandpaper close to the contour of the sliprings or commutator. Lift the brush to release pressure before returning the sandpaper for the next stroke. Sand until at least 80% of the brush surface is in contact with the slipring or commutator. Sand each of the remaining brushes one at a time as described above.

4.9.2 Check for proper "seating" by running the machine at no load minimum excitation, and observe the area of bare sliprings or commutator polished by the brushes. Reseating of brushes is required when brushes are replaced, or the sliprings or commutator are re-surfaced, or when excessive brush sparking is evident. Seat brushes on sliprings or commutator as described above.

WARNING

NEVER USE EMERY CLOTH TO SEAT BRUSHES

4.10 TURNING SLIPRINGS

4.10.1 When sliprings become too deeply pitted or grooved to be cleaned with sandpaper, the sliprings should be turned. Do not remove more material than is necessary to remove grooves or pitted areas from the slipring surface.

4.11 SANDING COMMUTATOR

4.11.1 Lift all brushes in their holders, install a strip of sandpaper with the abrasive side against the commutator. Using a hardwood block which has the same contour as the commutator surface, press the sandpaper surface against the commutator surface. Run the commutator at high speed while moving the block back and forth along the commutator surface parallel to the shaft.

4.12 TURNING COMMUTATORS

4.12.1 When the commutator is too deeply grooved or pitted to be cleaned with sandpaper, the armature must be mounted in a lathe and the commutator turned down. Make certain it is centered in the lathe.

4.12.2 Turn the commutator, removing only as much material as is necessary to remove grooves or pitted areas from the commutator surface. After turning, undercut the mica segments.

NOTE

IF COMMUTATOR IS NOT CONCENTRIC WITH THE TRUE SHAFT CENTER THE BRUSHES WILL BE FORCED TO MOVE IN THEIR HOLDERS TO CONFORM TO THE ECCENTRICITY OF THE COMMUTATOR WHICH WILL RESULT IN EXCESSIVE BRUSH WEAR AND SPARKING.

4.13 UNDERCUTTING COMMUTATOR

4.13.1 The commutator may be undercut by using either a square or "V" undercutting tool.

4.13.2 When a square undercutting tool is used, it should be slightly wider than the mica and well centered so that the mica fin as shown at (C), figure 4-2, page 19, is not left. Remove edges as shown at (A) by beveling as shown at (B).

4.13.3 When a "V" undercutting tool is used, the tool should be slightly wider than the mica to provide the bevel as shown at (E), figure 4-2, page 19. The mica fin shown at (D) will result if the undercutting is not deep enough. If the tool is not well centered a fin as shown at (F) will be the result. Always make certain the undercutting tool is centered and cuts deep enough to prevent these undesirable results.

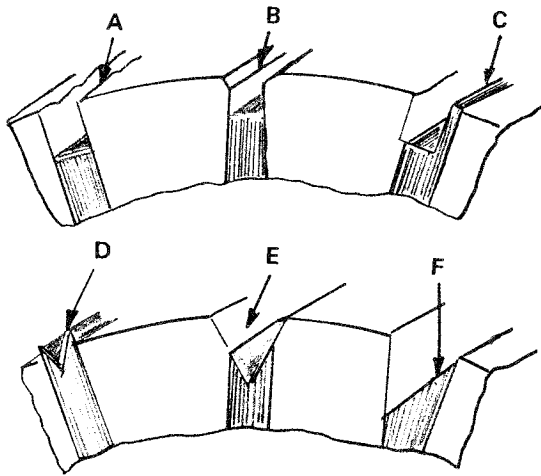

FIGURE 4-2 UNDERCUT COMMUTATOR

4.14 BEARINGS

4.14.1 The bearings are of the factory lubricated sealed or shielded cartridge ball bearing type on most KATO generators with rating under 75 KW. Sealed or shielded ball bearings do not require periodic replenishment of lubricating grease.

4.14.2 Most Kato generators with ratings over 75 KW have ball bearings which should be periodically lubricated.

Grease fittings are incorporated on Kato generators that have ball bearings which require periodic lubrication. A relief valve is generally installed in the drain ports on these machines.

Replenish grease at intervals and amounts listed on lubrication data plate attached to the generator.

DO NOT OVERFILL! INSPECT AND REMOVE GREASE FROM SLIP RINGS, BRUSHES AND OTHER INTERNAL PARTS OF THE GENERATOR.

4.15 BEARING REMOVAL

4.15.1 Remove the endbell to expose bearing. Use a puller to remove the bearing from the shaft. Protect the shaft end with a cap. Make certain puller applies pressure only against the bearing inner ring. If puller will not hook bearing inner ring, fabricate a split bushing and install it between the bearing and the puller hooks.

4.16 BEARING INSTALLATION

4.16.1 Heat the bearing to 250°F. in a clean temperature controlled circulating air oven Start the heated bearing onto the shaft. Then use a fiber or soft metal sleeve to tap bearing into place. Make certain that pressure is applied only to the bearing inner ring. Final position of bearing should be with inner ring resting against bearing shoulder on shaft. Assemble the generator after the bearing has cooled.

4.17 TROUBLESHOOTING

4.17.1 Troubleshooting is process of recognizing malfunctions of the system, intelligently analyzing the system malfunction, and making the necessary corrections to place the unit back into proper operation.

4.17.2 The systems operator is urged to be alert at all times for any signs of malfunctions. Any minor malfunctions should be corrected immediately to prevent serious malfunctions and down time. The troubleshooting chart lists symptoms of malfunctions which could possibly occur as well as the possible cause and remedy.

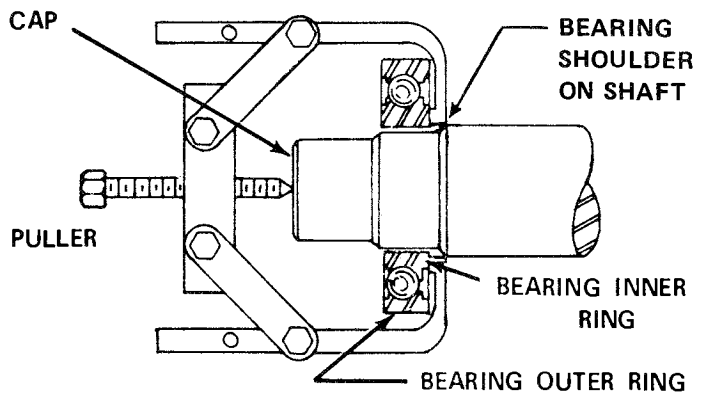

FIGURE 4-3 REMOVING BEARING FROM GENERATOR SHAFT.

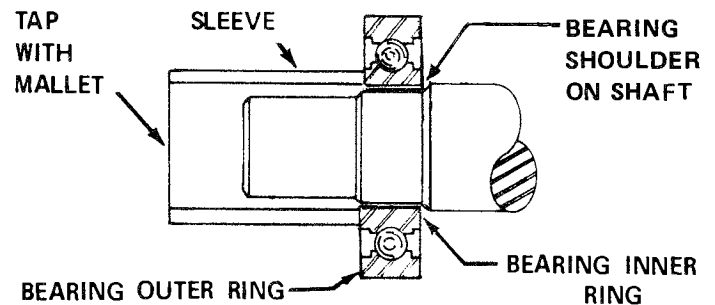

FIGURE 4-4 INSTALLING BEARING ON GENERATOR SHAFT.

TABLE 4-2
TROUBLESHOOTING CHART

SYMPTOM	POSSIBLE CAUSES	REMEDY
No Voltage	<p>Poor brush connection (either sliprings commutator, or brushes).</p> <p>Excitation (DC) lead open shorted or grounded to frame.</p> <p>Loss of residual magnetism.</p> <p>Short circuit in line or load.</p> <p>Field coils shorted or open.</p> <p>Shorted or grounded sliprings.</p> <p>Shorted commutator or shorted or open exciter armature windings</p>	<p>Clean and adjust or replace brushes. Clean, sand, or turn sliprings. Check that brush holders and brush wires are connected properly.</p> <p>Check with continuity lamp or ohmmeter. Replace defective leads.</p> <p>Flash field.</p> <p>Check for short in load by removing motors or appliances from the line. If short persists, the trouble is on the line. If line is clear, add motors or appliances one at a time until trouble is found.</p> <p>Check for open circuit and for short circuit. Replace rotor if defective.</p> <p>Disconnect lead wires and check slipring insulation with a megger. Repair or replace slipring assembly if defective.</p> <p>Repair commutator or replace exciter armature assembly.</p>
Low Voltage	<p>Excessive Load</p> <p>Improper adjustment of voltage adjust rheostat</p> <p>Underspeed.</p> <p>Insufficient excitation due to improper adjustment of voltage adjust rheostat</p> <p>Line loss</p> <p>High resistance connections (connections will be warm or hot).</p> <p>Brushes dirty or not properly seated.</p> <p>Sliprings or commutator dirty or in need of repair.</p> <p>Low power factor (AC only).</p>	<p>Reduce load to rated value. See generator nameplate for rating</p> <p>Adjust rheostat.</p> <p>Correct speed of engine or motor driving generator.</p> <p>Increase field excitation by adjusting voltage. adjust rheostat</p> <p>Increase size of line wire.</p> <p>Check connections. Replace or tighten defective connections</p> <p>Clean or replace brushes.</p> <p>Clean or repair as necessary.</p> <p>Reduce inductive (motor) load. Some AC motors draw approximately the same current regardless of load.</p>

SYMPTOM	POSSIBLE CAUSES	REMEDY
Low Voltage (continued)	<p>Weak field due to operating in warm temperature.</p> <p>Malfunction of voltage regulator when used</p>	<p>Improve the ventilation if generator is housed indoors. Field current can be increased providing the generator temperature does not exceed temperature rating stamped on the nameplate.</p> <p>Repair or replace voltage regulator.</p>
Fluctuating Voltage	<p>Irregular speed of prime mover.</p> <p>Poor brush contact.</p> <p>Loose terminal or load connections.</p> <p>Generator overloaded.</p> <p>Sliprings or commutator out of round or pitted</p> <p>DC excitation voltage fluctuating</p> <p>Shorted exciter field coil</p>	<p>Check and adjust governing device.</p> <p>Clean and adjust or replace brushes. Check brush tension spring pressure, 3 lbs. per square inch of brush surface nominal (2½ to 4 lbs./sq. inch generally satisfactory).</p> <p>Check connection. Tighten or replace defective connectors.</p> <p>Reduce load to rated value. See generator nameplate for rating.</p> <p>Turn sliprings or commutator on a lathe concentric with center of generator shaft</p> <p>Trace DC excitation through brushes, commutator, sliprings, and field coils and make repairs as necessary. Repair or replace defective parts.</p> <p>Test for short circuit. Replace defective coil.</p>
High Voltage	<p>Improperly adjusted voltage adjust rheostat</p> <p>Overspeed</p> <p>Operating in sub-zero temperatures.</p> <p>Defective voltage regulator</p>	<p>Adjust rheostat.</p> <p>Correct speed of prime mover.</p> <p>Increase field resistance.</p> <p>Repair or replace voltage regulator.</p>
Brush Sparking	<p>Sliprings and/or commutator surface not concentric to shaft, surface pitted or rough, slipring insulation defective, or high mica bars on commutator</p> <p>Loose brush holder.</p> <p>Lack of brush pressure</p> <p>Improper grade of brushes.</p> <p>Brushes not in commutating plane</p>	<p>Repair sliprings and/or commutator according to maintenance instructions.</p> <p>Re-align and tighten.</p> <p>Adjust or replace brush tension spring. 3 lbs./sq. in. per inch of brush surface nominal (2½ to 4 lbs./sq. inch).</p> <p>Replace with correct grade of brushes.</p> <p>Set to electrically neutral position.</p>

SYMPTOM	POSSIBLE CAUSES	REMEDY
Brush Sparking (continued)	Dirty sliprings. Open or shorted exciter armature Generator overloaded.	Sand lightly with 00 sandpaper. Check with growler. Repair or replace armature if defective. Check ammeter readings and compare with nameplate rating.
Overheating	Generator overloaded. Clogged ventilating passages. High room temperature. Insufficient circulation. Operating with excessive voltage. Low power factor (AC only). Unbalanced load on 4 wire, 3 phase generators. Motors operating off generator not designed for generator frequency and voltage. Excessive brush pressure. Bent shaft. Defective bearing.	Reduce load. Check ammeter readings and compare with nameplate rating. Clean air passages. Improve ventilation. Provide cross-ventilation Check voltage drop in distribution lines and connections. Reduce inductive load (motor), or install power factor improvement capacitors. The load on each leg should be as evenly balanced as possible and should not exceed the rated current on any leg. Motors operating from generator must be of the same frequency and voltage as stamped on the generator nameplate. Reduce spring pressure. 3 lbs./sq. inch of brush surface nominal (2½ to 4 lbs./sq. inch). Straighten or replace. Replace bearing.
Vibration	Improper mounting, or misalignment of coupling or drive pulley. Incorrect mounting of generator to engine. Transfer of vibration to generator set from another source. Defective bearing. Rotor out of balance following repair or replacement of generator rotor. Defective rotor windings due to excessive overspeed. Loose or broken fan Bent shaft due to excessive load.	Align motor and generator. Refer to Section 2. Re-install correctly. Refer to installation instructions contained in Section 2. Isolate generator set by installing vibration dampeners. Refer to Installation Instructions. Section 2. Replace bearing. Refer to Section 4 paragraphs 4.15 & 4.16. Balance rotor assembly with cooling fan installed. Replace or repair rotor. Correct cause of overspeed (defective engine governor and/or engine overspeed shutdown devices). Tighten or replace if broken. Straighten shaft or replace rotor.

4.18 DISASSEMBLY OF SINGLE BEARING GENERATOR

4.18.1 The following general instructions describe disassembly procedures for typical KATO single bearing generators and direct connected brush type DC exciters. Assemble the generator by reversing the order of the steps taken to disassemble the unit.

4.18.2 Disassemble generators of the type described above as shown in figure 4-5 as follows:

- a. Remove outlet box cover and disconnect generator load lines, exciter field leads, and generator field leads.
- b. Remove the generator from the engine by reversing assembly procedures. See Section 2, Installation.
- c. Remove exciter cover (1). Make sure brushes (11) and (22) are raised in holders before generator is removed from the engine.
- d. Remove generator base mounting bolts.
- e. Using slings attached to the generator lifting eyes remove generator from base.
- f. Disconnect exciter shunt field coil leads and generator field leads. Remove any clips securing field leads to exciter or generator frame.
- g. Remove exciter armature retaining bolt and washer (2).
- h. Remove exciter armature (3) and if used, aligning key (39).
- i. Remove commutator endbell bolts (17). Tap to loosen endbell (16).
- j. Check for shims in bearing well. Make certain shims, when incorporated, are reinstalled when generator is assembled.
- k. Remove rotor from drive end of generator.
- l. Remove bearings as described in paragraph 4.15.
- m. Unless damaged, do not remove brush ring assembly (14).

4.19 DISASSEMBLY OF TWO BEARING GENERATOR

4.19.1 The following general instructions describe disassembly procedures for typical KATO two bearing revolving field generators with direct connected brush type DC exciters. Assemble the generator by reversing the order of the steps taken to disassemble the unit.

4.19.2 Disassemble generator of the type described above and as shown in figure 4-6 as follows:

- a. Remove outlet box cover and disconnect generator load lines, exciter field leads and generator field leads.
- b. Remove the generator from the prime mover by reversing assembly procedures. See Section 2, Installation. Remove coupling or drive sheaves in accordance with the instructions supplied by the manufacturer of the coupling.
- c. Remove exciter cover (1). Make sure brushes (11) and (22) are raised in holders before generator is disassembled.
- d. Remove generator base mounting bolts.
- e. Using slings attached to the generator lifting eyes remove generator from base.
- f. Disconnect exciter shunt field coil leads and generator field leads. Remove any clips securing field leads to exciter or generator frame.
- g. Remove exciter armature retaining bolt and washer (2).
- h. Remove exciter armature (3), and when used, aligning key (38).
- i. Remove commutator endbell bolts (17). Remove endbell (16).
- j. Remove drive endbell bolts (36). Remove endbell (32).
- k. Check for shims in bearing wells. Make certain shims, when incorporated, are reinstalled when generator is assembled.
- l. Remove rotor from drive end of generator.
- m. Remove bearings (15) and (35) as described in paragraph 4.15.
- n. Unless damaged, do not remove brush ring assembly (14).

4.20 ORDERING RENEWAL PARTS

4.20.1 If a part should require replacement, order by part name and part number. Give the model, type and serial number of the generator. Replacement parts should always be of the same size and rating as the original equipment. Do not attempt to substitute similar parts. For fastest service direct parts order to:

Kato Engineering Company Parts Department,
1415 First Avenue North,
Mankato, Minnesota 56001.

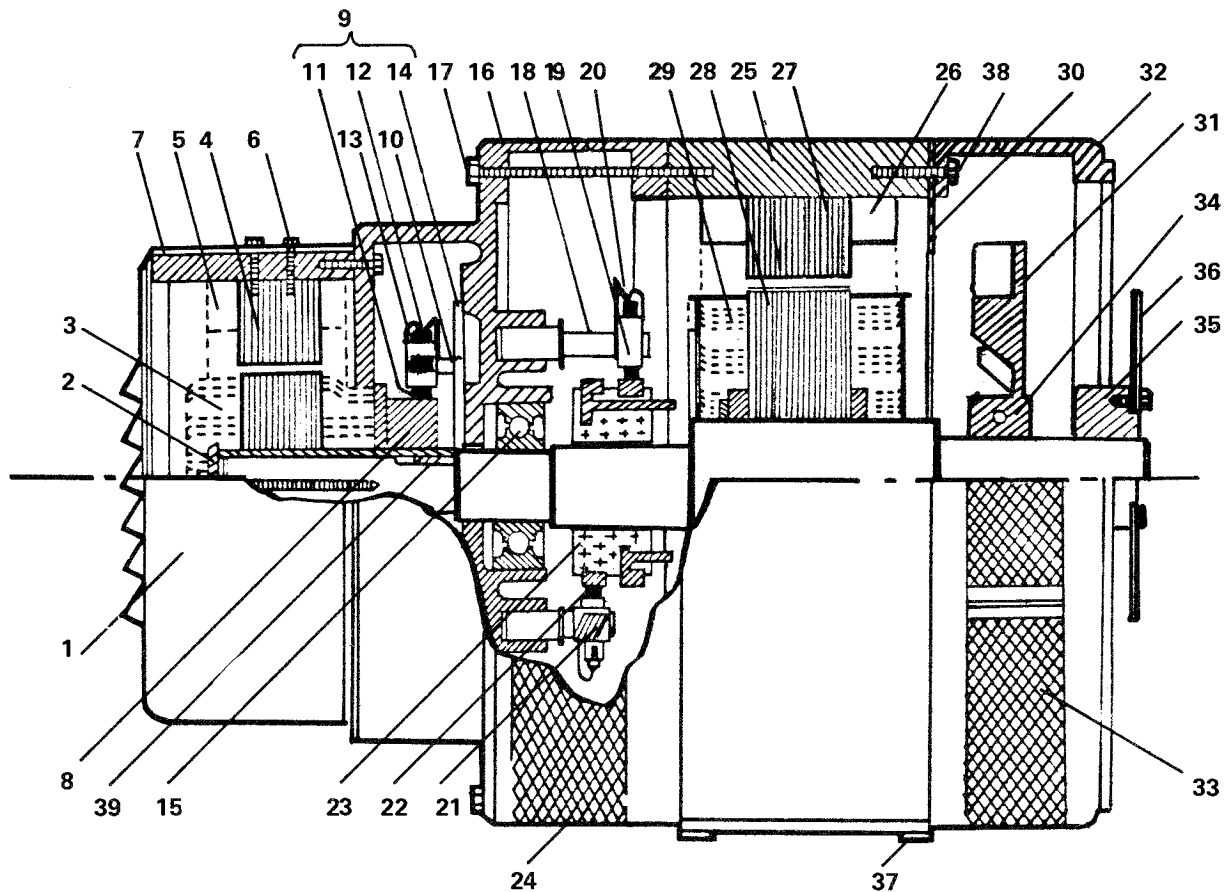

FIGURE 4-5 CROSS SECTIONAL VIEW - TYPICAL SINGLE BEARING REVOLVING FIELD AC GENERATOR WITH DIRECT CONNECTED BRUSH TYPE DC EXCITER.

NUMBER	PART DESCRIPTION	NUMBER	PART DESCRIPTION
1	Exciter Cover	20	Brush Tension Arm
2	Exciter Armature Retaining Bolt and Washer	21	Brush Tension Spring
3	Exciter Armature	22	Brush
4	Exciter Field Pole	23	Collector Ring Assembly
5	Exciter Field Coil	24	Air Intake Screen
6	Exciter Field Pole Mounting Bolt	25	Generator Frame
7	Exciter Frame	26	Generator Stator Coil
8	Commutator	27	Generator Stator Core
9	Brush Holder Assembly	28	Generator Field
10	Brush Holder Stud	29	Generator Field Coils
11	Brush	30	Baffle
12	Brush Tension Arm	31	Fan
13	Brush Tension Spring	32	Adapter Endbell, Drive End
14	Brush Holder Ring Assembly	33	Fan Screen
15	Bearing, Commutator End	34	Fan Hub
16	Endbell, Commutator End	35	Drive Hub
17	Endbell Bolt, Commutator End	36	Drive Plates
18	Brush Holder Stud	37	Generator Base and Mounting Pads
19	Brush Holder	38	Bolt, Drive Endbell
		39	Exciter Armature Aligning Key

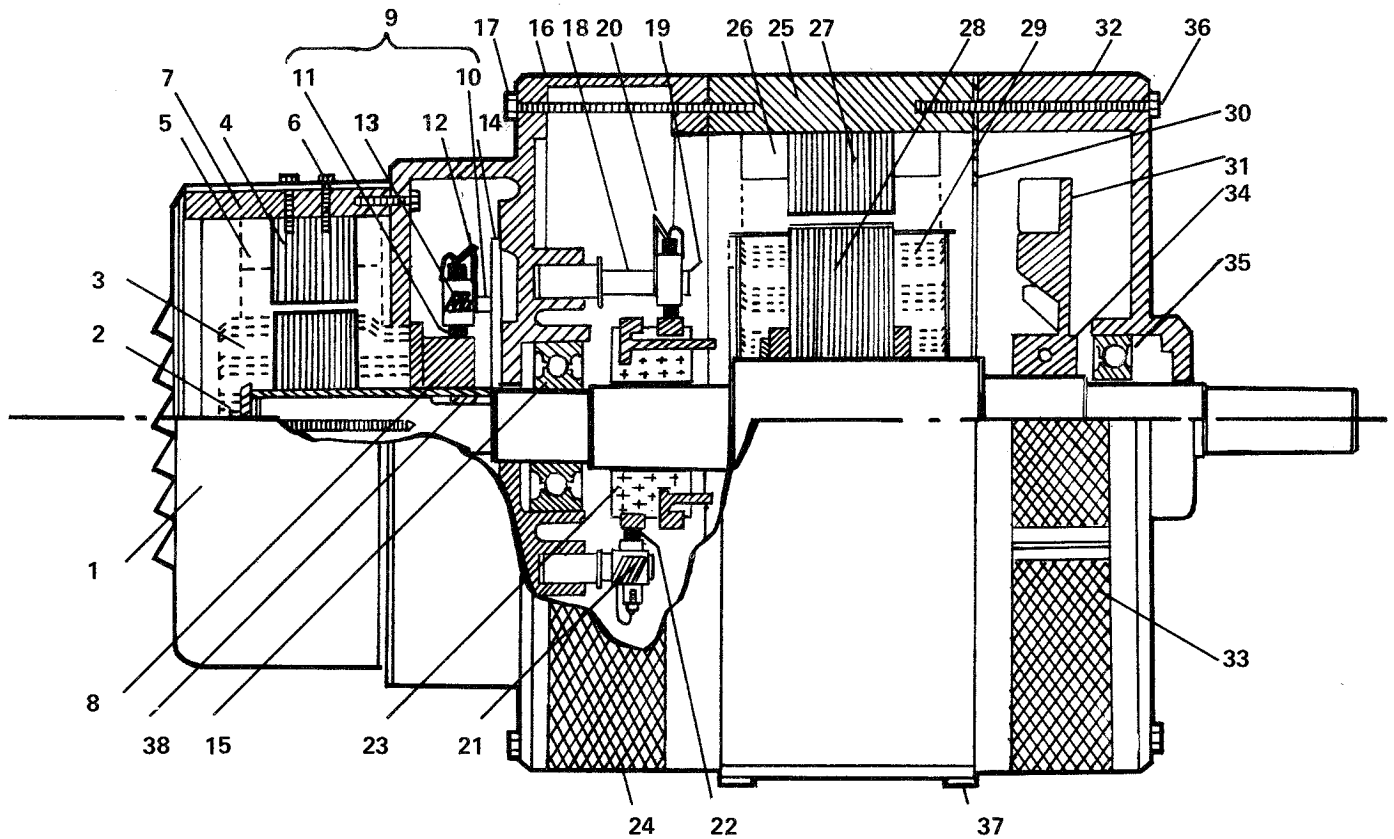

FIGURE 4-6 CROSS SECTIONAL VIEW - TYPICAL KATO REVOLVING FIELD TWO-BEARING GENERATOR WITH DIRECT CONNECTED BRUSH TYPE DC EXCITER.

NUMBER	PART DESCRIPTION	NUMBER	PART DESCRIPTION
1	Exciter Cover	20	Brush Tension Arm
2	Exciter Armature Retaining Bolt and Washer	21	Brush Tension Spring
3	Exciter Armature	22	Brush
4	Exciter Field Pole	23	Collector Ring Assembly
5	Exciter Field Coil	24	Air Intake Screen
6	Exciter Field Pole Mounting Bolt	25	Generator Frame
7	Exciter Frame	26	Generator Stator Coil
8	Commutator	27	Generator Stator Core
9	Brush Holder Assembly	28	Generator Field
10	Brush Holder Stud	29	Generator Field Coils
11	Brush	30	Baffle
12	Brush Tension Arm	31	Fan
13	Brush Tension Spring	32	Drive Endbell
14	Brush Holder Ring Assembly	33	Fan Screen
15	Bearing, Commutator End	34	Fan Hub
16	Endbell, Commutator End	35	Bearing, Drive End
17	Endbell Bolt, Commutator End	36	Bolt, Drive Endbell
18	Brush Holder Stud	37	Generator Base and Mounting Pads
19	Brush Holder	38	Exciter Armature Aligning Key

WARRANTY

Kato Engineering Company warrants that the apparatus manufactured by us will deliver its rated output, providing such apparatus is properly installed, properly cared for, and properly operated under normal environmental conditions.

Standard products manufactured by Kato Engineering Company are warranted to be free from defects in workmanship and material for a period of one year from date of shipment, and any products which are defective in workmanship or material will be repaired or replaced at the option of Kato Engineering Company. Final determination as to whether a product is actually defective rests with Kato Engineering Company. The obligation of Kato Engineering Company hereunder shall be limited solely to repair and replacement at its factory, of products that fall within the foregoing limitations, and shall be conditioned upon receipt by Kato Engineering Company of written notice within the warranty period of any alleged defects or deficiency. No products shall be returned to Kato Engineering Company without its prior consent. In no case can Kato Engineering Company accept shipping charges incurred either through return of defective items to its factory or return of repaired or replacement item to the user. Kato Engineering Company cannot assume responsibility or accept invoices for unauthorized repairs to its components, even though defective. In the case of components, parts, or units purchased by Kato Engineering Company, the obligation of Kato Engineering Company shall not exceed the settlement that it is able to obtain from the supplier thereof.

The life of the products of Kato Engineering Company depends to a large extent upon type of usage thereof, and Kato Engineering Company makes no warranty as to period of service nor as to fitness of its product for specific applications by the Buyer unless Kato Engineering Company specifically agrees to otherwise in writing after the proposed usage has been made known to it. In no event will Kato Engineering Company be liable for consequential or incidental damages or for any expense incurred by Buyer due to use or sale of products sold by Kato Engineering Company.

The foregoing warranty is exclusive and in lieu of all other warranties expressed or implied, including but not limited to any warranty of merchantability or of fitness for a particular purpose.

This Warranty does not apply to experimental or developmental products.



Kato Engineering Support

The brand you trust, the power you depend on. Include the serial number and model number for your machine in the email subject line.

Field Service

KatoService@mail.nidec.com

Parts

KatoParts@mail.nidec.com

Remanufacturing

KatoRemanufacturing@mail.nidec.com

Warranty/Quality Assurance

KatoWarranty@mail.nidec.com

Kato Engineering, Inc. | P.O. Box 8447 | Mankato, MN USA 56002-8447 | Tel: 507-625-4011
KatoEngineering@mail.nidec.com | www.KatoEngineering.com | Fax: 507-345-2798