

Instruction Manual

Description
Calibration

Voltage/Frequency Sensor

Publication
351-05027-00 (04-28-2005)



Nidec
KATO ENGINEERING™

Note: *Because of rapid changes in designs and processes and the variability of Kato Engineering's products, information in this manual must not be regarded as binding and is subject to change without notice.*

Introduction

Foreword

This manual contains instructions for installing, operating and maintaining Kato Engineering voltage/frequency sensors (VFS).

Safety instructions

In order to prevent injury or equipment damage, everyone involved in installation, operating and maintenance of the equipment described in this manual must be qualified and informed of the current safety standards that govern his or her work.

While “common-sense” prevention of injury or equipment damage cannot be completely defined by any manual (nor built into any piece of equipment), the following paragraphs define warnings, cautions, and notes as they are used in this manual:

Warning: Warnings identify an installation, operating or maintenance procedure, practice, condition, or statement that, if not strictly followed, could result in death or serious injury to personnel.

Caution: Cautions identify an installation, operating or maintenance procedure, practice, condition, or statement that, if not strictly followed, could result in destruction of or damage to equipment or serious impairment of system operation.

Note: Notes highlight an installation, operating or maintenance procedure, condition, or statement and are essential or helpful but are not of known hazardous nature as indicated by warnings and cautions.

Operating principles

The voltage/frequency sensor (VFS) provides generator set over and under voltage, and under frequency protection. All components are mounted on a printed circuit board. Included on the printed circuit board are three potentiometers, R2, R16, and R19, which are used to adjust the trip points for the over and under voltage. Dip switch SW1 is used to set the under frequency set point. Relays RL1, RL2, and RL3 are used for overvoltage, undervoltage, and underfrequency respectively.

Sensing voltage from the generator is applied to the VFS assembly A18, C18, A20, and A2. This voltage is rectified by a full wave rectifier comprised of diodes D1 through D6. The rectified voltage is applied across a voltage divider comprised of resistors R1, R3, and R4, and calibration potentiometer R2. A portion of the voltage across the voltage divider, taken at the wiper of R2 is fed through an active filter comprised of capacitors C1, C2, C3, and C4, Resistors R5, R6, R7, R8, and R9, and

an op amp/comparator from U1. The filtered voltage is monitored by the voltage detection ICs U1, U2, and U3.

U1 monitors for instantaneous overvoltage. When the generator voltage exceeds 130% of rated U1 will energize relay RL1 within 15 milliseconds.

U2 monitors for overvoltages in the range of 105% to 130% (adjustable via potentiometer R16). U2 will energize relay RL1 within 250 milliseconds of detection of an overvoltage condition.

U3 monitors for undervoltages in the range of 70% to 90% of rated voltage (adjustable via potentiometer R19). Relay RL2 is energized when the generator voltage rises above 95% of rated voltage. It is then de-energized when the voltage falls below the undervoltage set point for more than 250 milliseconds.

Underfrequency detection is accomplished by monitoring the zero crossing between phase A and phase C. U5 converts the zero crossing to a square wave. This square wave is fed to U6 which resets counter U7 on each rising edge of the square wave. Counter U7 then starts counting up again until it sees another reset pulse. If U7 counts up to the underfrequency set point (set by dip switch SW1), U10 goes low. U6 detects this and increments counter U8. If this condition persists for 16 consecutive times, relay RL3 is energized via the U9 thus indicating an under frequency condition.

Electrical connections

Electrical connections are made to the VFS via a 32 pin din connector. When connecting the sensor assembly, be sure to follow the wiring diagram provided with the controls and the VFS assembly drawing.

Calibration

Use the following procedure to check or set the trip point of a voltage sensor that monitors a generator. If a utility, or some other voltage is being monitored, it will be necessary to disconnect the voltage sensor from this source and connect a variable-voltage supply of the correct phase and voltage.

To check present over/under voltage set point:

1. Connect an AC voltmeter across phase A and C of the generator.
2. Adjust generator voltage to a minimum before starting it. Start the generator. While observing the voltmeter, slowly increase

Warning: *Dangerous voltages are present at the voltage sensor terminal board when monitoring a generator or utility. Contact with the live conductors may result in serious electrical shock or electrocution. Disconnect the power before making repairs, connecting test instruments, or removing or making connections*

the generator voltage until the overvoltage LED illuminates.
This is the overvoltage set point

3. Reduce the generator voltage slowly until the under voltage LED turns off. This is the under voltage set point.
4. The underfrequency setpoint can be determined by comparing the dip switch settings to the frequency tables, Table 1 and Table 2. To determine which table to use, check for the presence of either jumper J1 (400 Hz), or J2 (60 Hz).

To calibrate the over/under voltage range:

1. Start the generator and adjust for the desired rated voltage.
2. Place an ac voltmeter into testpoints TP1 (+), and TPG (-).
3. Start the generator and adjust the generator output to the desired rated voltage.
4. Adjust the "CAL" potentiometer, (located on the front of the VFS assembly), until the voltmeter reads 5.00 vdc.

To calibrate the overvoltage setpoint, perform the following:

1. Turn the "OV" potentiometer, (located on the front of the VFS assembly), fully clockwise.
2. Start the generator and adjust for the desired rated output voltage.
3. Slowly turn the "OV" pot counter clockwise, until the "OV" LED turns on.

To calibrate the undervoltage setpoint, perform the following:

1. Turn the "UV" potentiometer, (located on the front of the VFS assembly), fully clockwise.
2. Start the generator and adjust for the desired rated output voltage.
3. Slowly turn the "UV" pot counter clockwise, until the "UV" LED turns off.

Minimum Frequency (Hz)	8	7	6	5	4	3	2	1
60	0	0	0	0	0	1	0	1
59	0	1	1	0	0	1	1	0
58	0	1	1	0	1	0	0	0
57	0	1	1	0	1	0	1	0
56	0	1	1	0	1	0	1	1
55	0	1	1	0	1	0	1	1
54	0	1	1	0	1	1	1	1
53	0	1	1	1	0	0	0	1
52	0	1	1	1	0	1	0	0
51	0	1	1	1	0	1	0	0
50	0	1	1	1	1	0	0	0
49	0	1	1	1	1	0	1	1
48	0	1	1	1	1	1	0	1
47	0	1	1	1	1	1	1	1
46	1	0	0	0	0	0	1	0
45	1	0	0	0	1	0	0	0
44	1	0	0	0	1	0	0	0
43	1	0	0	0	1	0	1	1
42	1	0	0	0	1	1	1	1
41	1	0	0	1	0	0	1	0
40	1	0	0	1	0	1	1	0

Adjust the dip switch SW1 to achieve the desired frequency shut down point. 1 = closed, 0 = open.

Table 1: 60 Hz Frequency Setpoints

Minimum Frequency (Hz)	8	7	6	5	4	3	2	1
400	0	1	1	1	1	0	0	0
395	0	1	1	1	1	0	1	0
390	0	1	1	1	1	0	1	1
385	0	1	1	1	1	1	0	1
380	0	1	1	1	1	1	1	0
375	1	0	0	0	0	0	0	0
370	1	0	0	0	0	0	1	0
365	1	0	0	0	0	1	0	0
360	1	0	0	0	0	1	0	1
355	1	0	0	0	0	1	1	1
350	1	0	0	0	1	0	0	1
345	1	0	0	0	1	0	1	1
340	1	0	0	0	1	1	0	1
335	1	0	0	0	1	1	1	1
330	1	0	0	1	0	0	0	0
325	1	0	0	1	0	0	1	0
320	1	0	0	1	0	1	1	0
315	1	0	0	1	1	0	0	0
310	1	0	0	1	1	0	0	1
305	1	0	0	1	1	1	0	1
300	1	0	1	0	0	0	0	0

Adjust the dip switch SW1 to achieve the desired frequency shut down point. 1 = closed, 0 = open.

Table 2: 400 Hz Frequency Setpoints

Appendix

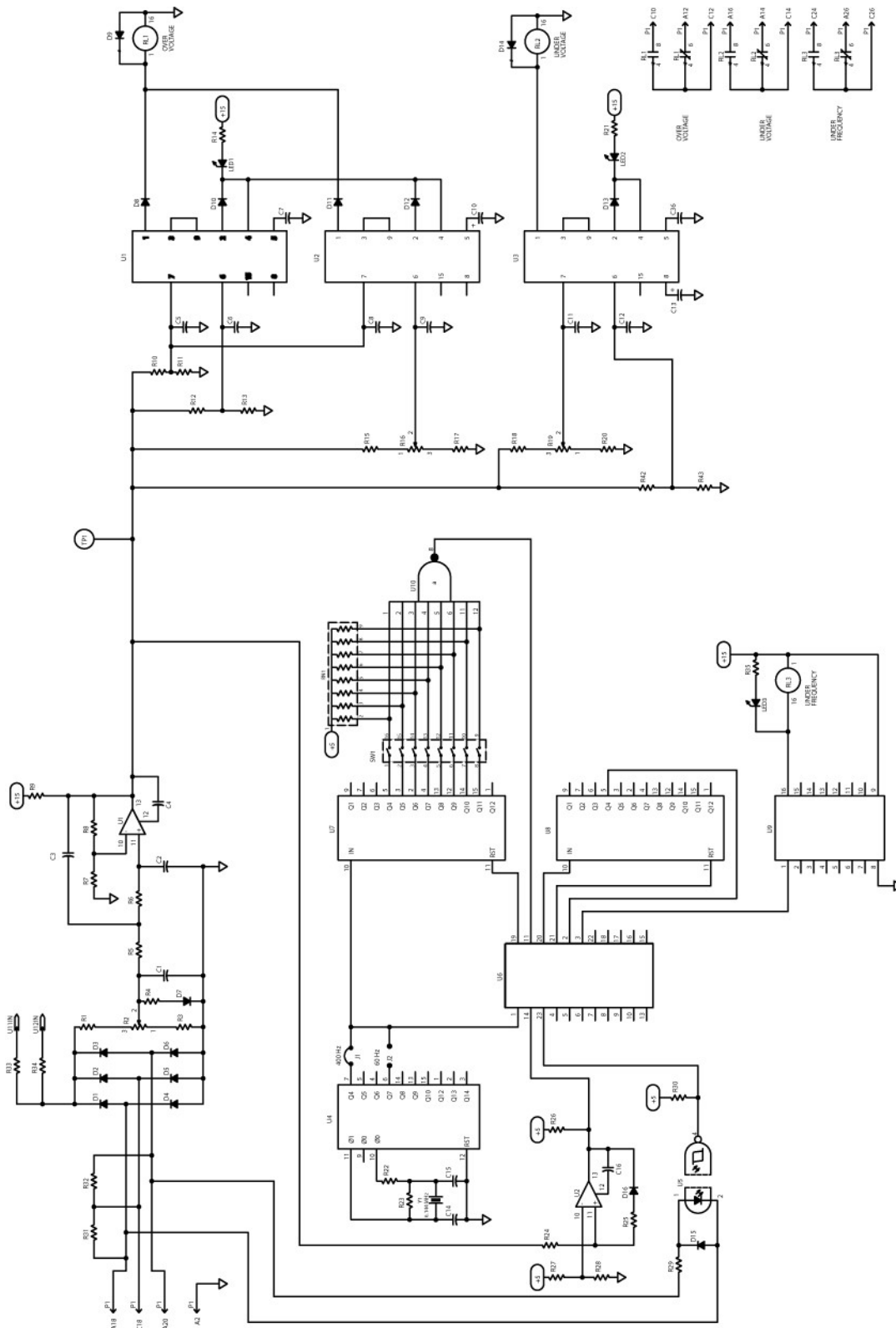

Figure 1: Over/Under Voltage and Under Frequency Assembly, Drawing 1

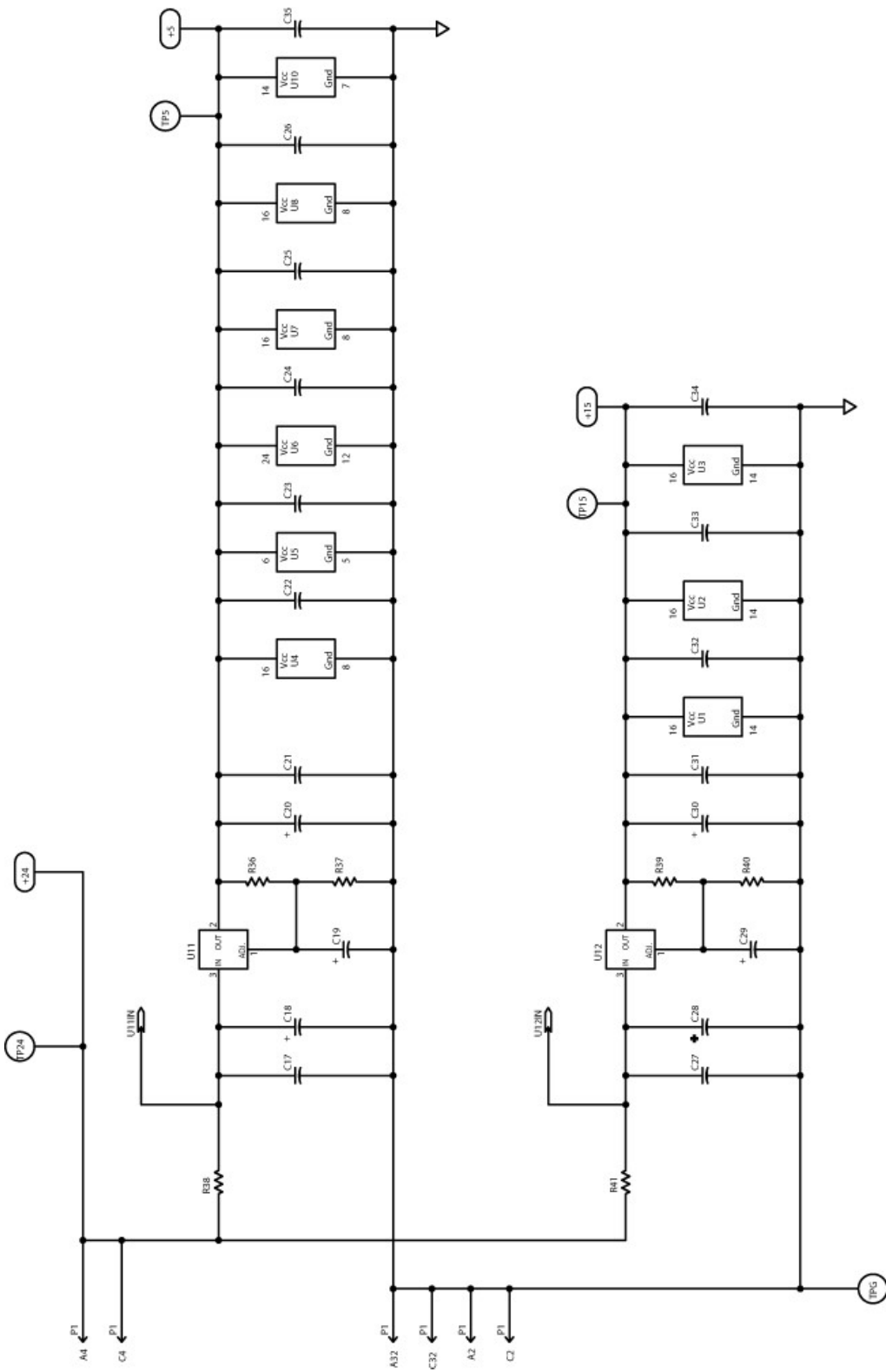
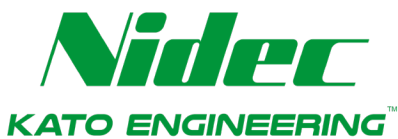

Figure 2: Over/Under Voltage and Under Frequency Assembly, Drawing 2



Kato Engineering Support

The brand you trust, the power you depend on. Include the serial number and model number for your machine in the email subject line.

Field Service

KatoService@mail.nidec.com

Parts

KatoParts@mail.nidec.com

Remanufacturing

KatoRemanufacturing@mail.nidec.com

Warranty/Quality Assurance

KatoWarranty@mail.nidec.com

Kato Engineering, Inc. | P.O. Box 8447 | Mankato, MN USA 56002-8447 | Tel: 507-625-4011
KatoEngineering@mail.nidec.com | www.KatoEngineering.com | Fax: 507-345-2798