



User Manual

KRM2000

Kato Rotor Monitoring System

Protected by Patents:

US #6794883B2

EP #1499903A4

Revision 1.0.5

January 5, 2018

Manual # 352-56001-09



PLEASE READ THIS MANUAL AND ALL INCLUDED MANUALS IN ITS ENTIRETY BEFORE UNPACKING, INSTALLING, AND OPERATING THE KRM2000™ SYSTEM. IF YOUR MANUAL CAME ON A CD, READ ALL THE FILES INCLUDED ON THE CD.

This page intentionally left blank (back of front cover).

Copyright © 2013 Kato Engineering

Because of rapid changes in design and processes and the variability of Kato Engineering's products, information in this manual must not be regarded as binding and is subject to change without notice.

Kato Engineering Inc.
P.O. Box 8447
Mankato, MN USA 56002-8447
Tel: 507-625-4011
Fax: 507-345-2798
Email: katoengineering@mail.nidec.com
Internet: www.kato-eng.com



WARNING: IN ORDER TO PREVENT INJURY OR EQUIPMENT DAMAGE, EVERYONE INVOLVED IN THE INSTALLATION, OPERATION, AND MAINTANCE OF THIS PRODUCT MUST BE QUALIFIED AND TRAINED OF THE CURRENT SAFETY STANDARDS THAT GOVERN HIS OR HER WORK.

Table of Contents

1	Revision History	9
2	Introduction.....	9
2.1	Safety Instructions.....	9
2.2	System Description	10
2.2.1	Inductive Power Loop Antenna	12
2.2.2	Dipole Receiver Antenna.....	12
2.2.3	Receiver	12
2.2.4	Power Supply.....	12
2.2.5	Transmitter.....	12
3	Specifications.....	13
3.1	Dimensions.....	13
3.2	Electrical.....	15
3.3	Environmental	15
3.4	Certifications	15
4	Installation.....	16
4.1	Mounting.....	16
4.1.1	Receiver	16
4.1.2	Transmitter.....	17
4.1.3	Inductive Power Loop Antenna	17
4.1.4	Dipole Antenna.....	17
4.1.5	Power Supply	18
4.2	System Connections	19
4.2.1	Receiver	19
4.2.2	Transmitter.....	20
4.2.3	Loop Antenna.....	20
4.2.4	Power Supply	21
4.2.5	System Diagram.....	21
4.3	Electrical Installation.....	22
4.3.1	Relay Outputs, Receiver	22
4.3.2	Digital Outputs, Receiver.....	23
4.3.3	Loop Antenna Output, Receiver	24
4.3.4	Communication Interfaces, Receiver.....	24
4.3.5	Transmitter.....	25
4.3.6	Power Supply	25
5	Feature Description.....	26
5.1	Functional Block Diagram	26
5.2	Theory of Operation.....	26
5.3	Setup Features	28
5.3.1	Loop Tuning Type	28
5.3.2	Loop Tuning Step Size.....	28
5.3.3	Communications Setup.....	28
5.3.4	EEPROM	30
5.4	Protection Features.....	30
5.4.1	Service Fault	30
5.4.2	Malfunction.....	30

5.4.3	Ground Fault	31
5.4.4	PWM Re-enable Time Limit	31
5.4.5	Loop Undervoltage	31
5.4.6	Loop Overcurrent.....	31
5.4.7	Radio Link Error	31
5.4.8	Diode Fault.....	31
5.5	Monitoring Features	32
5.5.1	Data Points	32
6	Maintenance.....	33
7	Troubleshooting	34
8	Appendix.....	35
8.1	Configure TCP/IP Settings of Communication Modules.....	35
8.2	Ethernet/IP.....	37
8.2.1	CIP Object Dictionary.....	37
8.3	Data Tables.....	49
8.4	Flash Programming Updates	51
8.5	Sensing Filter Option	53

List of Figures

Figure 1	Typical Location of Rotor Monitoring System Components.....	11
Figure 2	Receiver Dimensions.....	13
Figure 3	Transmitter Dimensions	14
Figure 4	Power Supply Dimensions	14
Figure 5	Receiver DIN Rail Mounting Provision Option 1	16
Figure 6	Receiver DIN Rail Mounting Provision Option 2.....	16
Figure 7	Transmitter Mounting.....	17
Figure 8	Dipole Antenna Mounting.....	18
Figure 9	Power Supply Mounting.....	18
Figure 10	Terminal Connections, Receiver	19
Figure 11	Terminal Connections, Transmitter.....	20
Figure 12	Terminal Connections, Loop Antenna	20
Figure 13	Terminal Connections, Power Supply	21
Figure 14	System Diagram, Example	21
Figure 15	Receiver Relay Outputs Wiring Detail.....	22
Figure 16	Receiver Digital Outputs Wiring Detail	23
Figure 17	Receiver Digital Output Internal Circuit	23
Figure 18	Receiver Loop Antenna Wiring Detail.....	24
Figure 19	Transmitter Wiring Detail	25
Figure 20	24VDC Power Supply Wiring Detail	25
Figure 21	KRM2000™ Functional Block Diagram	26
Figure 22	Anybus IPConfig Scan Example	36
Figure 23	TCP/IP Configurable Settings	36
Figure 24	Flash File Selection	51
Figure 25	Flash Port Configuration	52
Figure 26	Flash Download Window	52
Figure 27	Sensing Filter Wiring/Installation Detail	53

List of Tables

Table 1 Revision History	9
Table 2 Terminal Connection Descriptions, Receiver	19
Table 3 Supported Active Network Modules	28
Table 4 Replacement/Spare Parts	33
Table 5 Troubleshooting Guide	34
Table 6 CIP Instance Attributes Model	37
Table 7 Ethernet/IP CIP Object Dictionary	37
Table 8 General Control Register	49
Table 9 Part Numbers Table Index	49
Table 10 Unsigned 32 Bit Integer Min/Max Value Table	49
Table 11 Floating Point Min/Max Value Table	49
Table 12 GPIO Test Mode Enable Min/Max Table.....	50
Table 13 GPIO Test Mode Data Min/Max Table	50

1 Revision History

The following table contains the Revision History which pertains to this document only.

Table 1 Revision History

Revision	Date	Description	Engineer
1.0.0	11/2013	Original	KMM
1.0.1	2/2014	Modified figures 14 and 15	KMM
1.0.2	3/2014	Added vibration to environmental section	KMM
1.0.3	3/2014	Updated power supply ratings	KMM
1.0.4	7/2014	Added DFD LED/output toggling info to diode fault protection features section and to troubleshooting table. Also corrected DFD output levels related to malfunction and diode fault	AMG

2 Introduction

This manual contains the instructions to properly install, operate, and maintain Kato Engineering's KRM2000™. The KRM2000™ is a rotor monitoring system for series redundant brushless exciters that also monitors insulation resistance and detects ground failures utilizing wireless telemetry. This system is primarily used on large turbine driven synchronous generators.

2.1 Safety Instructions

In order to prevent injury or equipment damage, everyone involved in installation, operating, and maintenance of the KRM2000™ system described in this manual must be qualified and trained in the current safety standards that govern his or her work.

While “common-sense” prevention of injury or equipment damage cannot be completely defined by any manual (nor built into any piece of equipment), the following paragraphs define warnings, cautions, Notices, and Important as they are used in this manual.



WARNING: Warnings identify an installation, operating or maintenance procedure, practice, condition, or statement that, if not strictly followed, could result in death or serious injury to personnel.



CAUTION: Cautions identify a hazardous situation that if not avoided could result in minor or moderate injury.

NOTICE: Notices identify an installation, operating or maintenance procedure, practice, condition, or statement that, if not strictly followed, could result in destruction of or damage to equipment or serious impairment of system operation.

IMPORTANT: Important messages are informational only.

2.2 System Description

The KRM2000™ rotor monitoring system utilizes 5 components to provide the basic functions as described previously.

- (1) Stationary induction power loop antenna
- (2) Stationary dipole receiver antenna
- (3) Non-rotating receiver
- (4) Power supply
- (5) Rotor mounted transmitter

Figure 1 demonstrates these components and their general location. This diagram does not demonstrate every application, but is provided as a generic guide to how the system is laid out.



WARNING: WHEN WORKING OR MOUNTING ANY COMPONENTS, MAKE SURE THE PRIMEMOVER AND GENERATOR ARE NOT CAPABLE OF BEING ENERGIZED. USE APPROPRIATE LOCK OUT/TAG OUT PROCEDURES. FAILURE TO DO SO MAY RESULT IN SERIOUS INJURY.

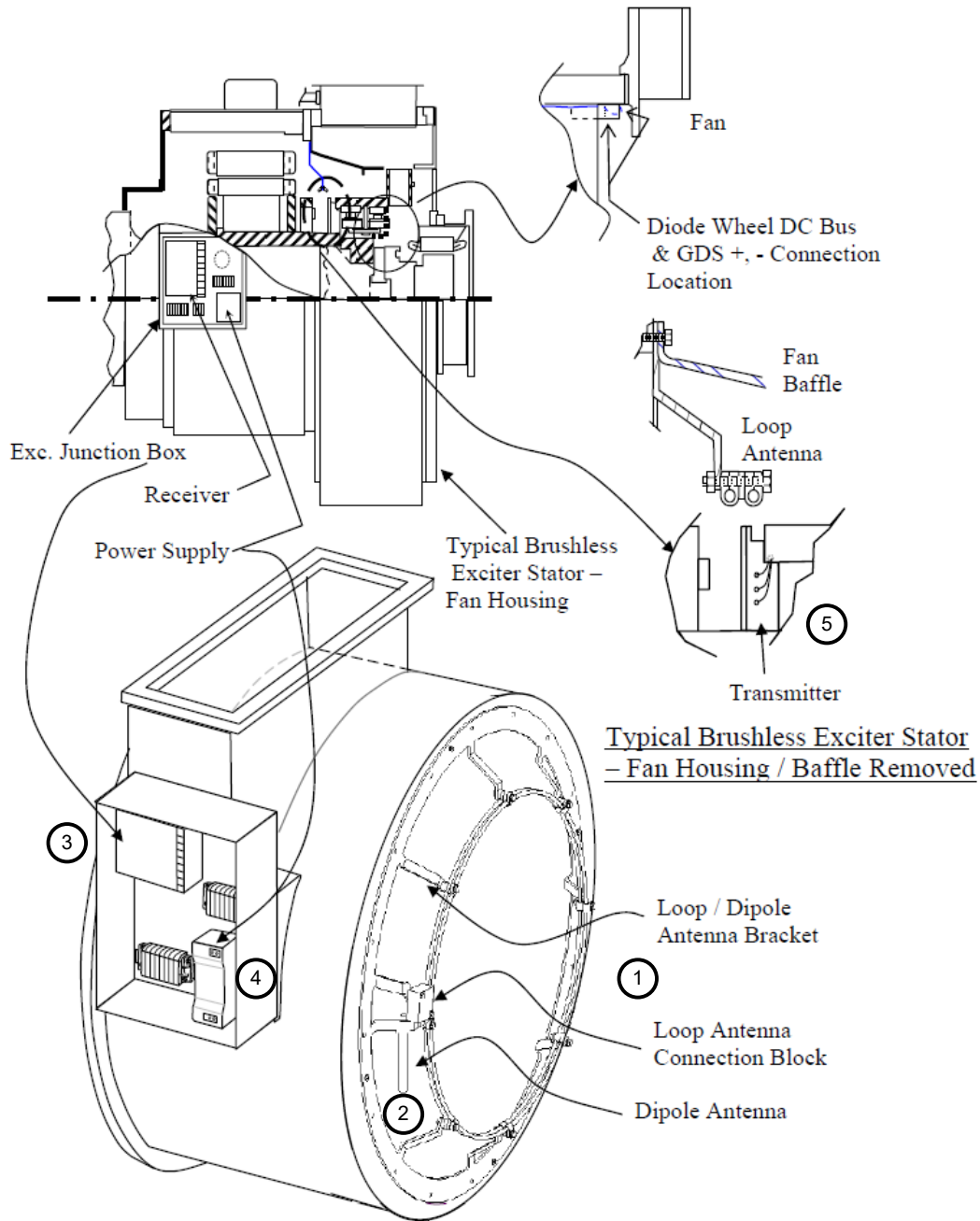

Figure 1 Typical Location of Rotor Monitoring System Components



WARNING: WHEN OPERATING THE KRM2000™, MAKE SURE ALL PROTECTIVE GUARDS ARE IN PLACE. FAILURE TO DO SO MAY RESULT IN SERIOUS INJURY OR DEATH.

2.2.1 Inductive Power Loop Antenna

The loop antenna provides power to the rotor mounted transmitter through inductive coupling. The loop antenna is powered by the receiver, which is connected through the loop antenna connection block.

2.2.2 Dipole Receiver Antenna

The dipole receiver antenna is used to collect the data wirelessly from the rotor mounted transmitter back to the stationary mounted receiver. This antenna is mounted to the loop antenna bracket, and is connected to the receiver through BNC connectors and a coaxial cable.

2.2.3 Receiver

The stationary mounted receiver collects the data from the rotor mounted transmitter through the dipole antenna. The radio operates at 418MHz. The DSP based receiver is able to translate this data and can indicate the status of the ground fault and diode fault (optional) detectors. Utilizing the on board communications, the end-user can also collect data for diagnostic purposes.

2.2.4 Power Supply

The power supply provides 24 Vdc regulated power to the KRM2000™ receiver. The input power range is 85 Vac to 263 Vac (50-60Hz), making it suitable for applications worldwide.

2.2.5 Transmitter

The transmitter is mounted on the shaft of the rotor, and is capable of monitoring the insulation resistance between the brushless exciter, generator field, and the rotor shaft (ground). It also measures the main field voltage and has an optional auxiliary channel for monitoring an optional rotating diode fault detector. This data is transmitted wirelessly to the stationary receiver. The transmitter is powered through the inductive loop antenna.

3 Specifications

This section contains all of the dimensional, electrical, and environmental specifications, as well as the certifications for the KRM2000™.

3.1 Dimensions

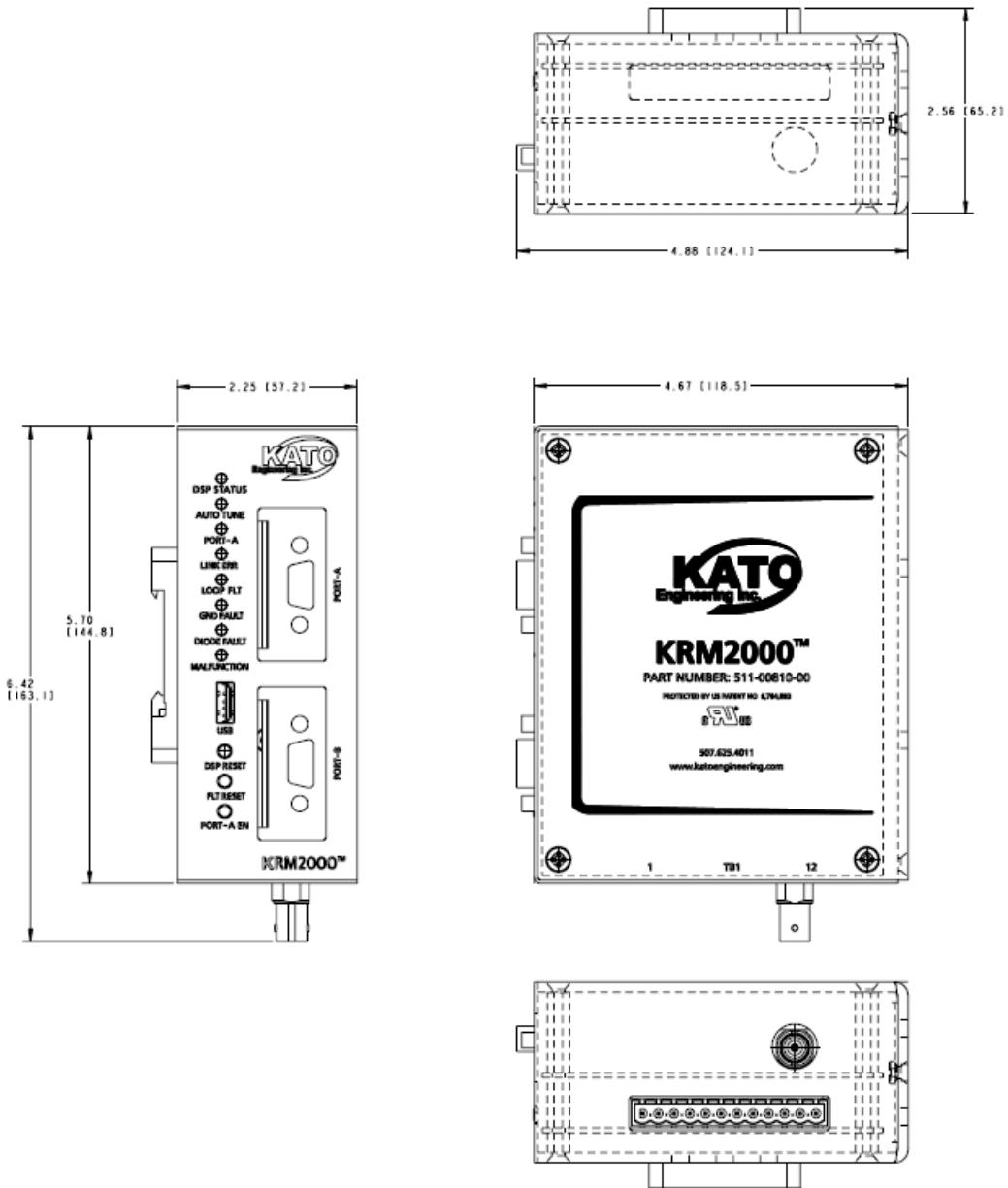

Figure 2 Receiver Dimensions

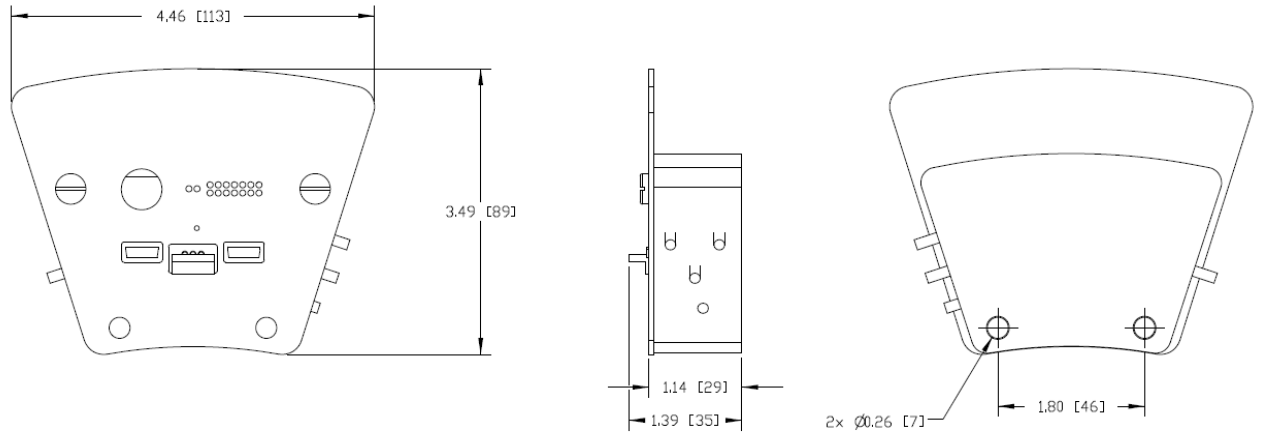

Figure 3 Transmitter Dimensions

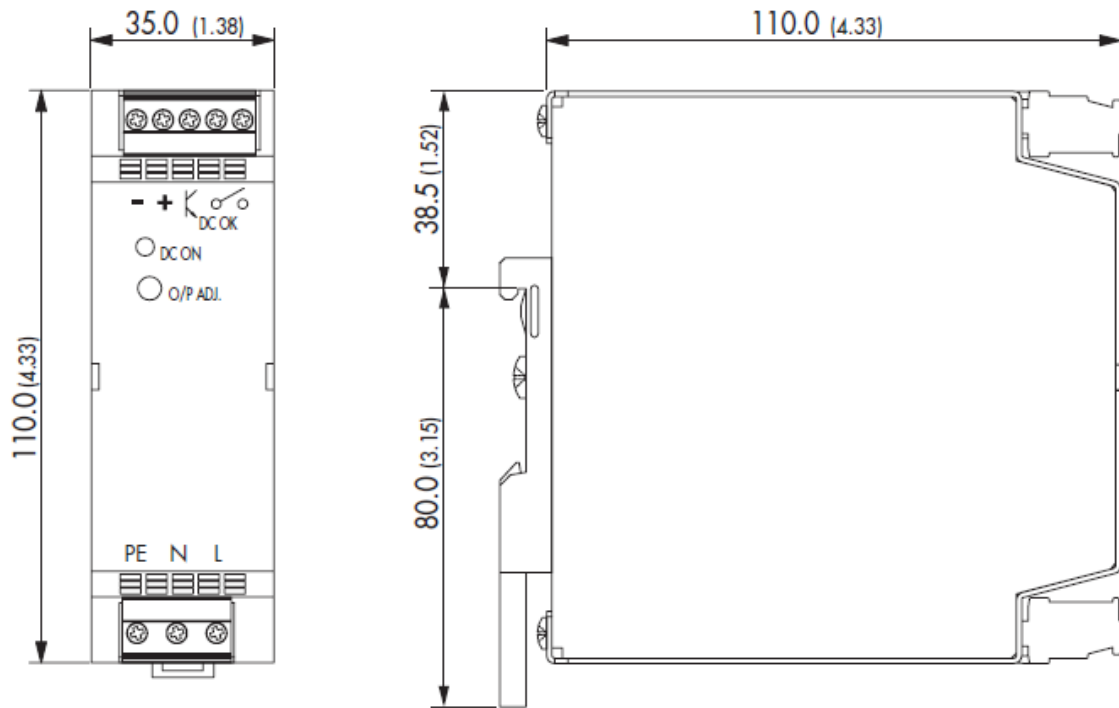

Figure 4 Power Supply Dimensions

3.2 Electrical

CONTROL POWER (RECEIVER)

DC Voltage:	18 – 31V
DC Burden:	12.5W
Polarity Protected:	No

RELAY OUTPUTS (RECEIVER)

Type:	Form A x 3 Sealed
Contact Material:	AgSnO ₂
Operate Time:	10ms
Release Time:	10ms
Minimum Load:	100mA@5VDC
Maximum Load:	2A@250VAC Resistive (120000 Operations)

DIGITAL OUTPUTS (RECEIVER)

Type:	Source/Sink x 3
Internal Source Resistance:	Open Drain with internal pull up resistance of 10kΩ to V+
Maximum Sink Current:	250mA

3.3 Environmental

TEMPERATURE

Operating:	-40 to +70°C
Storage:	-40 to +85°C

SHOCK

TBD

VIBRATION

MIL-STD-167-1A

3.4 Certifications

UL RECOGNITION

UL recognized under standard 508, UL file number E233284.

4 Installation

This section describes the mechanical and electrical installation requirements for the KRM2000™ rotor monitoring system.

4.1 Mounting

The mounting requirements for the transmitter, receiver, inductive power loop antenna, power supply, and the dipole antenna are described in this section.

4.1.1 Receiver

The KRM2000™ receiver can be DIN rail mounted in the horizontal direction, with a minimum of 3" of space from the terminal blocks to allow for easy removal. There are two optional locations for the DIN rail mount, as shown in Figure 5 and 6.

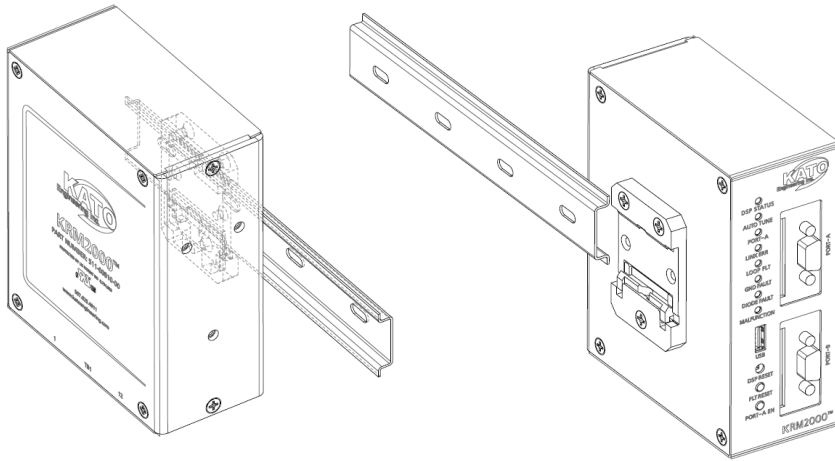

Figure 5 Receiver DIN Rail Mounting Provision Option 1

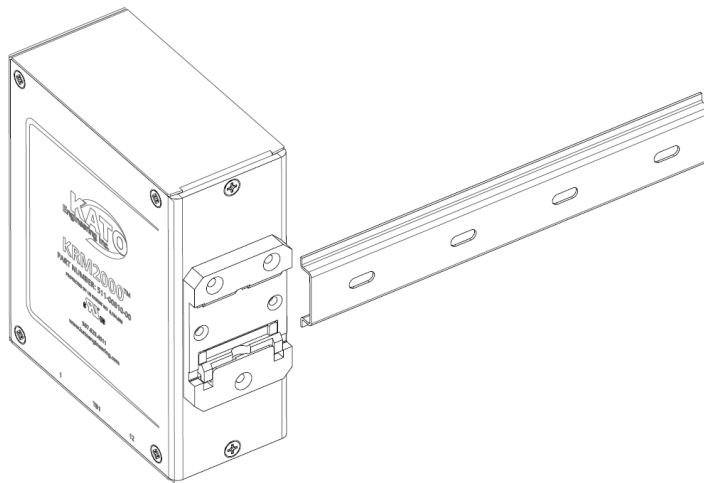

Figure 6 Receiver DIN Rail Mounting Provision Option 2

4.1.2 Transmitter

The transmitter is typically mounted on the diode wheel at the end of the shaft on the rotor. The figure below shows the typical mounting requirements.

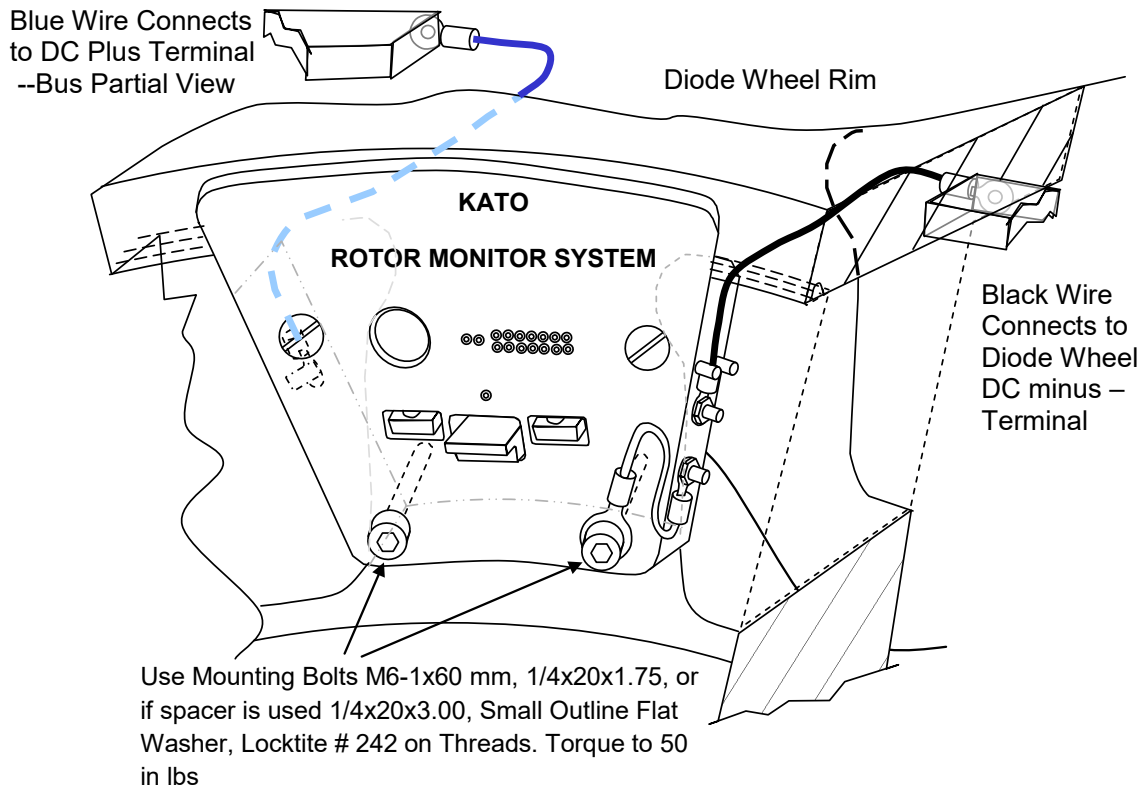

Figure 7 Transmitter Mounting

4.1.3 Inductive Power Loop Antenna

The inductive power loop antenna is mounted to a loop antenna bracket, which is typically located on the end frame at the exciter end of the generator. Various loops sizes are available to best fit the application.

4.1.4 Dipole Antenna

The dipole antenna is mounted to the antenna bracket through a BNC connector. The antenna bracket is found on the loop antenna bracket.

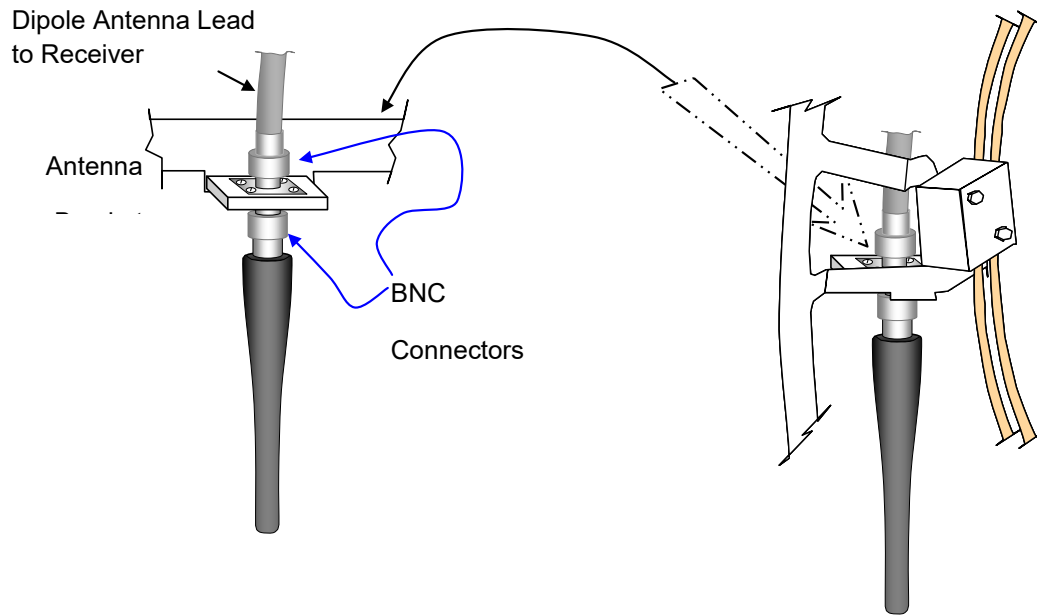

Figure 8 Dipole Antenna Mounting

4.1.5 Power Supply

The power supply is DIN rail mountable. For proper cooling of the power supply, there must be 3.15 inches of space above and below the power supply, and 1.97 inches for both of the sides.

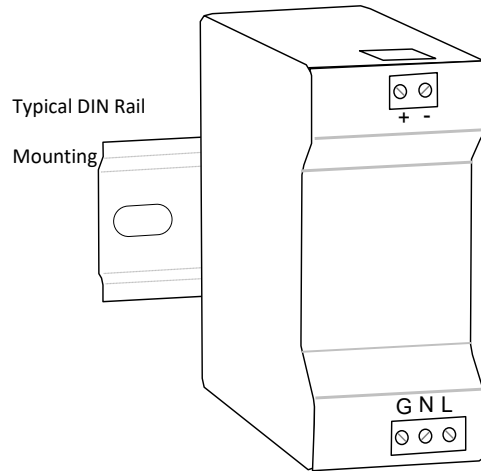

Figure 9 Power Supply Mounting

4.2 System Connections

The following section demonstrates the terminal requirements as well as overall system connections required for the KRM2000™ rotor monitoring system. Connections are to be made as instructed in this manual and/or by any outside system drawings as governed by Kato Engineering only.

4.2.1 Receiver

Table 2 Terminal Connection Descriptions, Receiver

TERMINAL NAME	TERMINAL #	DESCRIPTION
+24V	TB1-1	+24V power supply input
COM	TB1-2	Power supply common
MF RLY	TB1-3	Malfunction relay
GF RLY	TB1-4	Ground fault relay
SERVICE RLY	TB1-5	Service relay
RLY COM	TB1-6	Relay common
GF OUT	TB1-7	Ground fault signal output (source/sink)
DF OUT	TB1-8	Diode fault signal output (source/sink)
MF OUT	TB1-9	Malfunction signal output (source/sink)
N/C	TB1-10	No connect
ANT-H	TB1-11	Loop antenna driver high
ANT-L	TB1-12	Loop antenna driver low
ANTENNA	BNC CONNECTOR	Coax connector for receiver antenna
PORT-A	-	Communications port (Bluetooth)
PORT-B	-	Communications port (USB, see Note 1)

Note 1: See Kato Engineering for supported communication options.



Figure 10 Terminal Connections, Receiver

4.2.2 Transmitter

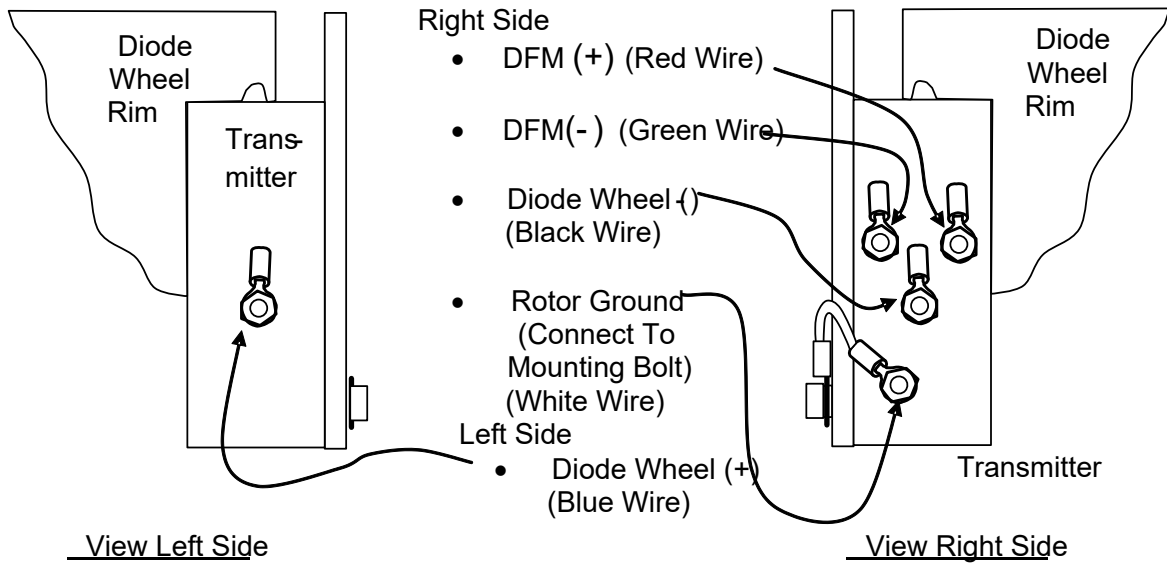

Figure 11 Terminal Connections, Transmitter

4.2.3 Loop Antenna

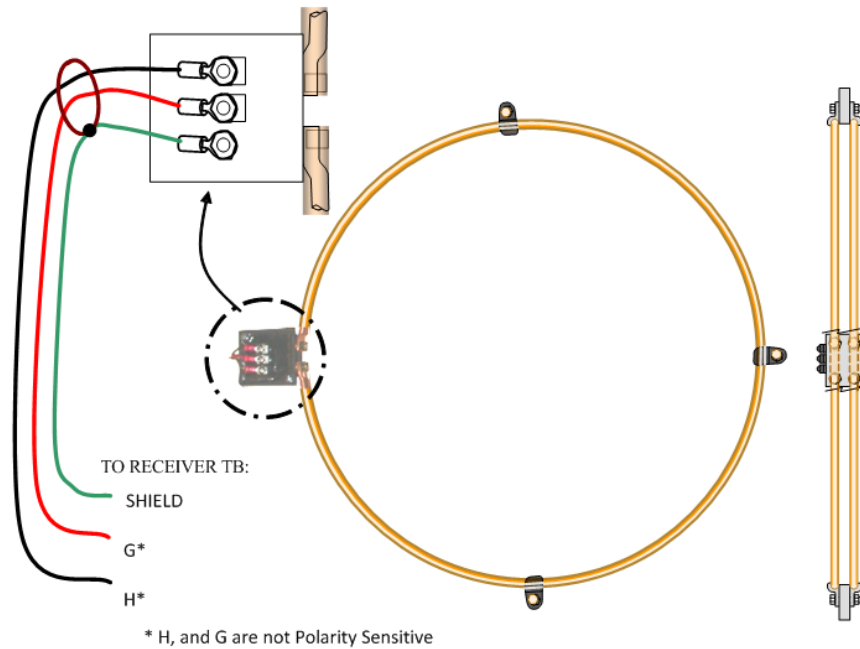

Figure 12 Terminal Connections, Loop Antenna

4.2.4 Power Supply

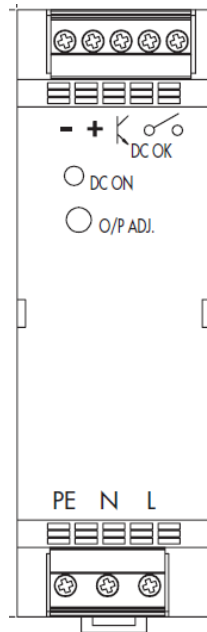

Figure 13 Terminal Connections, Power Supply

4.2.5 System Diagram

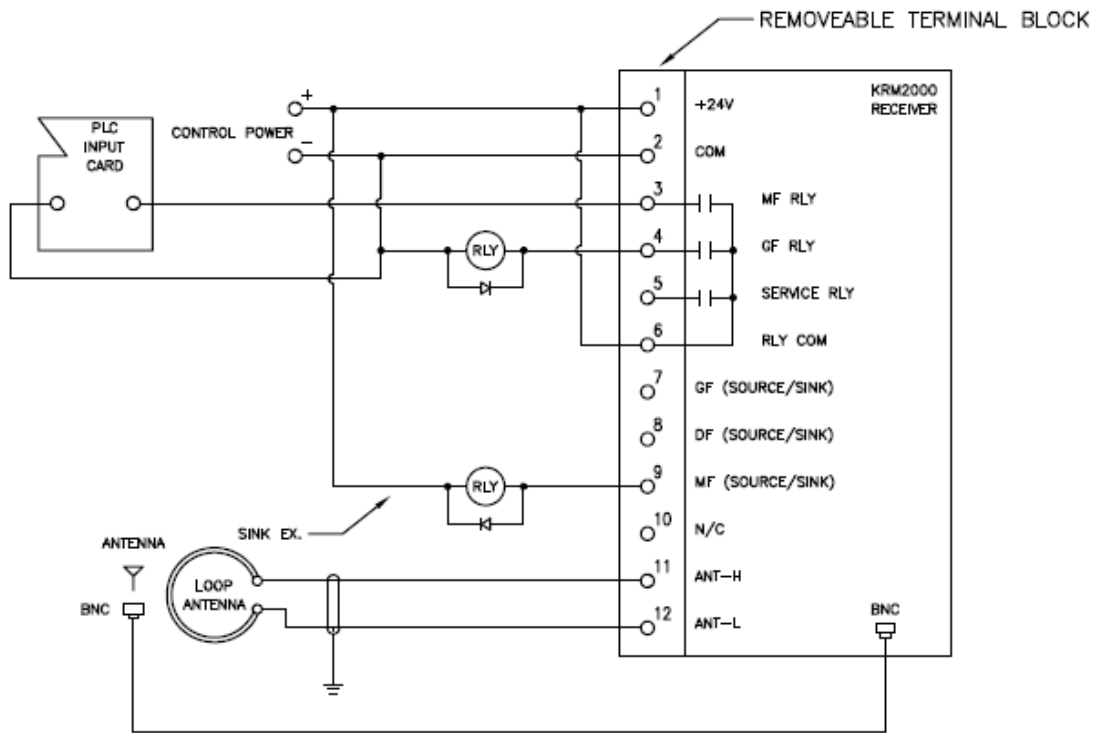

Figure 14 System Diagram, Example

4.3 Electrical Installation

This section provides in more detail the proper electrical installation procedure for the KRM2000™. The intent of this section is to provide the user/installer with the most typical connection schemes available to this device. It is not possible to present all of the available connection types in this manual.

NOTICE: INSTALLATION OF THIS PRODUCT SHOULD BE DONE BY QUALIFIED PERSONNEL ONLY. ALL LOCAL AND NATIONAL ELECTRICAL CODES THAT APPLY SHALL BE FOLLOWED. FAILURE TO DO SO MAY RESULT IN EQUIPMENT DAMAGE.

CAUTION: TO PREVENT DAMAGE OR INJURY, IT IS IMPORTANT THAT ALL PROCEDURES ARE FOLLOWED AS STATED IN THIS MANUAL DURING THE INSTALLATION/OPERATION OF THIS PRODUCT.

4.3.1 Relay Outputs, Receiver

There are three relay outputs that can be utilized for status indication. The Malfunction (MF) and Ground Fault (GF) relays are Form A (NO) style contacts. The Service relay is also a Form A contact, but is operated as a NC contact. When power is applied, the contact will close during normal operation. If power is removed or an internal error has been found, then the contact will open.

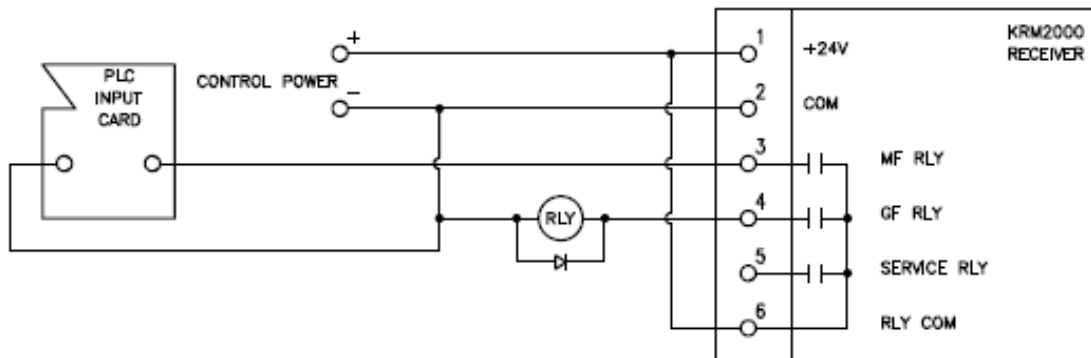

Figure 15 Receiver Relay Outputs Wiring Detail

4.3.2 Digital Outputs, Receiver

The KRM2000 receiver has three digital outputs that can be utilized in either a source or sink configuration. The output source current is limited by an internal 10kΩ resistor, while the input sink current is limited to 250mA per input. If more current is required, slave relays can be added to increase the current capabilities.

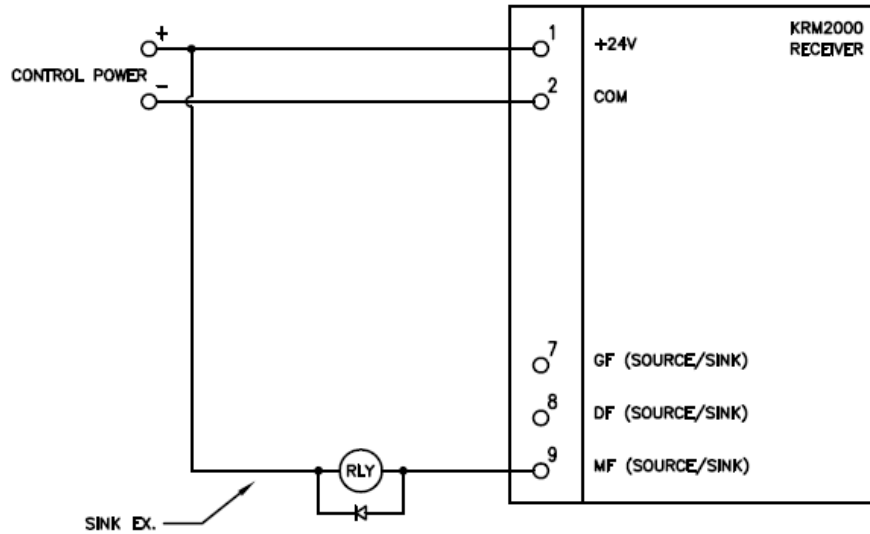

Figure 16 Receiver Digital Outputs Wiring Detail

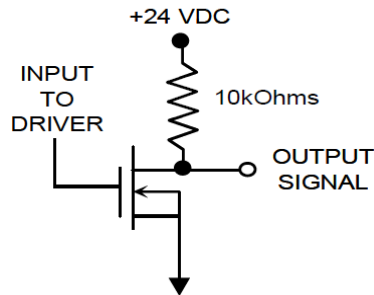

Figure 17 Receiver Digital Output Internal Circuit

4.3.3 Loop Antenna Output, Receiver

The loop antenna output of the receiver is an AC output that connects to the antenna bracket. This output is not polarity sensitive. The maximum cable length that can be utilized for this connection is 20ft, and can actually be shorter depending on the installation.

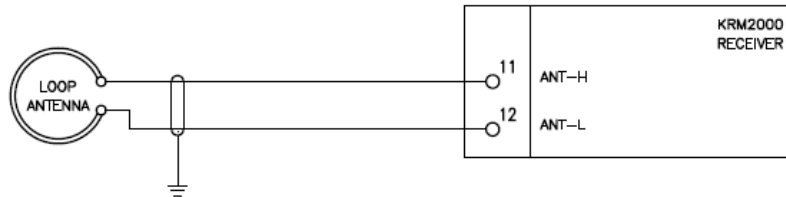

Figure 18 Receiver Loop Antenna Wiring Detail

4.3.4 Communication Interfaces, Receiver

The KRM2000™ provides tremendous flexibility through its communication interface. There currently are three connections provided for communication: Serial USB, and two custom ports that can be interchanged with various communication protocols. The USB input provides the ability to perform firmware upgrades. The custom port connections provide a host of protocol options for the user when connecting to other outside devices as well as the GUI, with some of the more common types shown below:

- CANopen
- DeviceNet
- Modbus RTU & TCP
- Profibus
- RS232/RS422/RS485
- USB
- Ethernet/IP
- Bluetooth
- ControlNet

Other protocol options are available, and can be inquired about through Kato Engineering. The standard options provided with the KRM2000™ are USB and Bluetooth.

4.3.5 Transmitter

The transmitter provides the ground fault protection through the generator field connections and the connection to the rotor itself (ground). Verify all connections are in place and secure before operation.

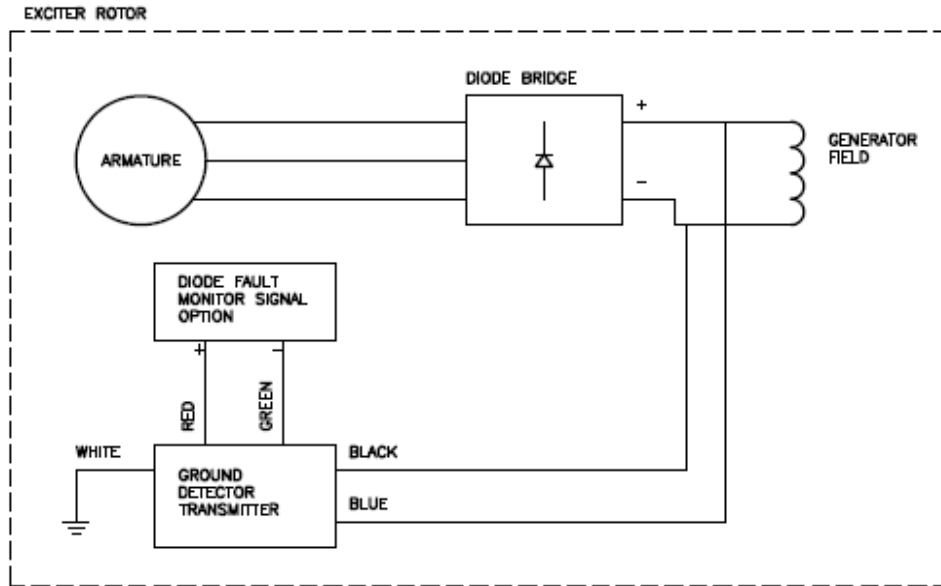

Figure 19 Transmitter Wiring Detail

4.3.6 Power Supply

The 24VDC power supply provides control power to the KRM2000 receiver.

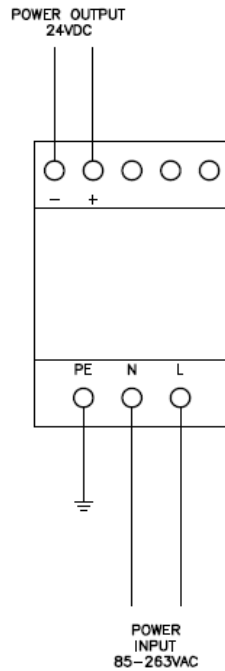

Figure 20 24VDC Power Supply Wiring Detail

5 Feature Description

This section will describe all of the functional features and parameters provided with the KRM2000™ system. All programmable features are done through the KRM2000™ receiver.

5.1 Functional Block Diagram

The KRM2000™ provides flexibility in communications, allowing for the user to collect data and make settings adjustments through many different protocols. The stationary receiver contains a DSP that does all of the conversion of data that was collected over the air from the rotating transmitter.

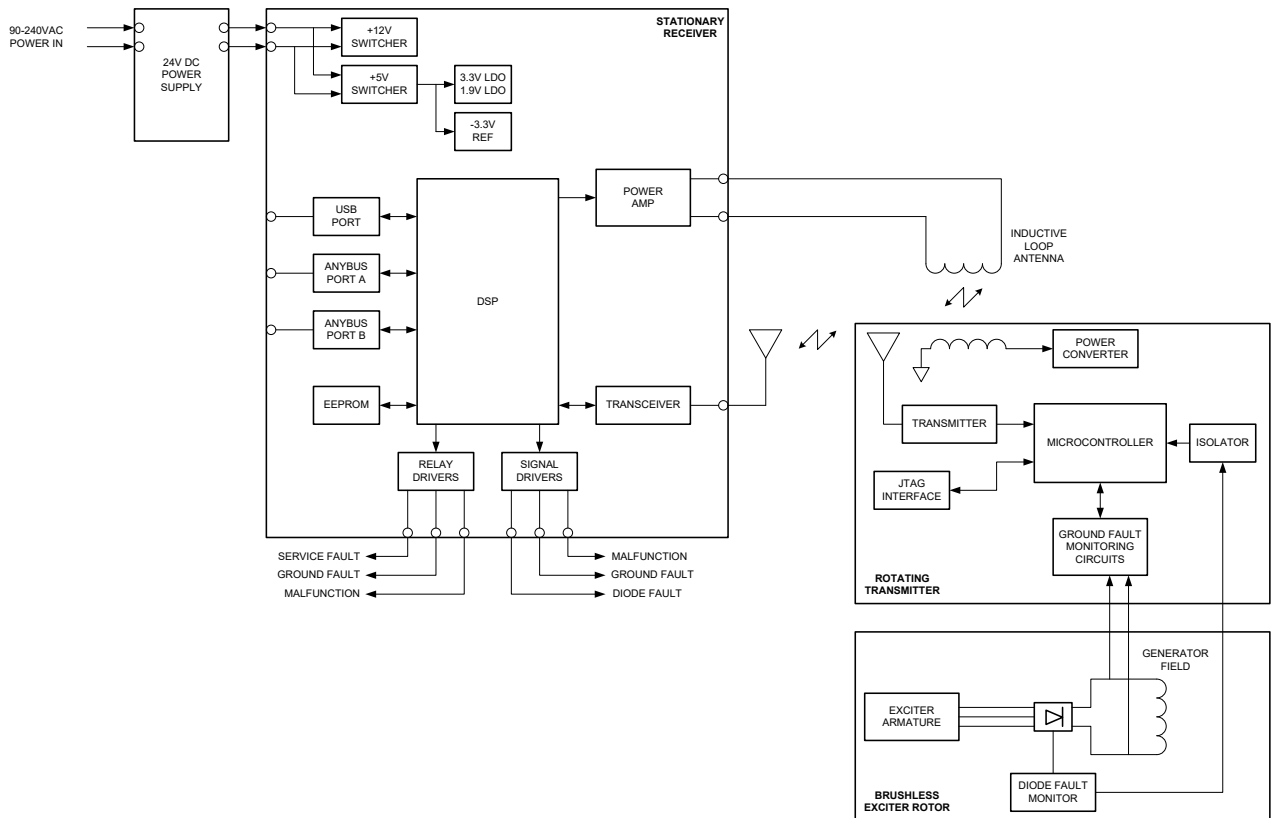

Figure 21 KRM2000™ Functional Block Diagram

5.2 Theory of Operation

The rotating transmitter module contains circuitry capable of detecting the occurrence of a generator ground fault condition. In this case the ground fault condition is defined as an electrical leakage path modeled as a resistance that may exist from any point along the field winding to the rotor shaft (ground). An effective ground fault detector must respond to ground faults at any location on the field winding. The ground fault detection circuitry makes an electrical connection between the rotor ground and the generator field introducing a small DC voltage that floats the field above ground. The transmitter monitoring circuits sense leakage currents to ground by using a pulsed DC bias voltage method. Using this method, the transmitter detector determines the actual field leakage resistance to ground and not just the leakage current. The leakage current to ground is dependent not only on the value of field leakage resistance to ground, but also on the magnitude

of field excitation voltage and also the location of the ground fault. Thus an alarm based on the leakage current only would result in a ground fault alarm threshold that varies significantly with field voltage/fault location. Monitoring the actual field leakage resistance eliminates this variation resulting in an alarm point, which is much more predictable, thus reducing the possibility of premature or intermittent ground fault alarms.

The ground detector transmitter sends ground fault leakage resistance parameter measurements to the stationary receiver. When the generator field to ground fault leakage resistance falls below a programmable threshold (nominally 10K Ω), the receiver activates the GROUND FAULT alarm signal. The receiver performs the ground resistance calculations based on the data it receives from the rotor monitor/transmitter.

The rotating transmitter monitors the leakage to ground resistance by injecting a one-to-two pulse-per-second square wave between the shaft (ground) and the negative rotating field lead. The connection of the ground fault detection circuits of the transmitter to ground is via a resistor, two diodes, and terminals. The voltage rating of the diodes is sufficient to withstand a 500 Volt leakage test ("megger") of the rotor with a 2 X safety factor. Incorrect polarization of the "megger" will result in an indication of excessive leakage but will not damage the ground detector circuitry. The detector connects to both the positive and the negative field leads. The leakage current that flows during each half of the square wave is measured by monitoring the voltage across the sensing resistor. This sensed voltage plus the field voltage is sampled by a microprocessor.

The digitized data is transmitted in "packets" at a carrier frequency of approximately 418 MHz to the receiver. A dipole antenna is used to transmit this signal to the receiver. The data "packets" are of short duration so the same data will be transmitted several times during each transmit cycle.

The receiver loop antenna is the inductive power loop. This antenna powers the transmitter via an RF link thereby allowing the transmitter to be operational at all speeds with or without excitation. Power for the rotating element is supplied through this inductive loop antenna. This power transmission antenna consists of two series-connected loops, spatially parallel, circumferentially located just outside the path followed by the rotating element. The frequency of this power is approximately 100 KHz.

The loops are secured somewhat away from the frame steel on insulated standoffs at eight equally spaced locations. The two parallel loops are necessary because the rotor assembly can move up to approximately one inch axially between cold and full operating temperature. The dual loop system allows for a larger axial misalignment. Tuning of the power transmitter (in the stationary element) is not required. A dynamic tuning process is being used in this application, using a Digital Signal Processor for control. The KRM2000™ receiver currently has the capability of tuning utilizing two different methods. The first and default method is to continuously step the loop frequency to maintain the maximum loop voltage, with the step size being programmable. The second method is to do a sweep and hold. The frequency is swept from 95 to 130 kHz and the peak voltage is recorded during that sweep. The loop frequency is then set based on the peak value found through the sweep. The loop is swept from 3.5 kHz below resonant frequency to 3.5 kHz above resonant frequency every 10 seconds to account for variations in resonant frequency. Both methods help optimize the transmission efficiency to the loop and help account for loop mis-alignment, which ultimately means more power available to the rotating transmitter.

5.3 Setup Features

The initial setup for the KRM2000™ allows the user to configure the device to their system. This section details this function.

5.3.1 Loop Tuning Type

The KRM2000™ receiver has the ability to tune the inductive loop antenna utilizing one of two methods. One method is to continuously step the loop frequency (either up or down) in order to maintain a maximum loop voltage. Another method is to do a periodic sweep and hold on the loop voltage. This method will do a sweep from 95 to 130 kHz and hold on the peak value of the voltage. Thereafter, “mini-sweeps” are performed approximately every 10 seconds to account for variations in the resonant frequency. The default method is to continuously step the loop frequency, while either method is selectable through the user interface.

5.3.2 Loop Tuning Step Size

When the receiver is utilizing the continuous step method, the tuning step size needs to be considered. The programmable element for this feature is simply the tuning step size.

5.3.3 Communications Setup

The KRM2000™ is capable of communications using various different protocols that can be selected either at the time of the order or by contacting the Kato Engineering Support or Sales group directly.

The KRM2000™ is equipped with 3 different communications port. A factory USB port, and several selectable communications module ports labeled as Port A and Port B. By default these ports come with a Bluetooth module installed on Port A and a USB module installed on Port B. Please reference the relevant sections below for a detailed description of each port. If your KRM2000™ has been configured with different modules please see the *Appendix* section of this manual for the particular module present on the device.

See the below table for a list of the currently supported active network modules. These network modules can be used in either Port A or B and can be requested at the time of purchase. If a different network is required per the application please contact Kato Engineering sales or support staff to request that network be added.

Table 3 Supported Active Network Modules

Module Name
Ethernet/IP 1 Port
Ethernet/IP 2 Port

5.3.3.1 Factory USB Port

The factory USB port is a type A female USB port that is used exclusively for the purpose of downloading firmware to the KRM2000™. Please see the *Appendix* section of this manual for instructions for downloading new firmware to the KRM2000™ in the event that a firmware upgrade is required in the field. Each time a connection is made to a new KRM2000™ a driver will have to be downloaded and installed. This driver is used to create a Virtual Com Port (VCP) which allows the

connecting device to view the KRM2000™ as a serial port. Generally the operating system of the connecting device will handle the device driver installation and port binding. However it is recommended that prior to connecting to the device the relevant driver be downloaded from this link in order to insure the latest driver is always being used for the desired operating system.

<http://www.ftdichip.com/Drivers/VCP.htm>

5.3.3.2 Port A (Bluetooth)

The Bluetooth module is provided as a cable replacement for device communications in the event the KRM2000™ is located in a hard to reach location.

In order to connect the KRM2000™ to a device (computer, phone, etc.) the KRM2000™ needs to be paired to the device. To pair to a device follow the steps provided below:

1. Press and hold the “Port-A EN” button located on the front panel of the KRM2000™ until the “Port-A” LED becomes illuminated.
2. When this LED is illuminated it indicates that the Bluetooth module in Port-A is in discoverable mode and can be paired to a device. Once the KRM2000™ has been put into discoverable mode a user will have 30 minutes to pair to a device before it is removed from discoverable mode.
3. Depending on device and operating system this step will vary depending on application. At this time follow the Bluetooth pairing procedure for the particular device.
4. The KRM2000™ will show up as an “Anybus-CC Passive Bluetooth” device.
5. If a password or key is prompted use “0”.
6. The device should now be paired to the KRM2000™ and show up in the list of paired Bluetooth devices of the device.

Please make note that immediately after pairing to the device it is possible to make a connection to the KRM2000™ however making a connection to a already previously paired device requires that the “Port-A EN” button be pressed.

To connect to a previously paired device, one will need to press and release the “Port-A EN” button. The “Port-A” LED will flash to indicate the Bluetooth module is in connectable-only mode, the KRM2000™ will disable the Bluetooth module after a period of 60 minutes (if NO connections are communicating with the Bluetooth module).

Press and release the “Port-A EN” button while in discoverable, or connectable-only mode, to remove the Bluetooth module from either of these modes. Note that the “Port-A EN” LED will stop illuminating after a short delay but the Bluetooth module will **only** be removed from its operating mode if NO connections were communicating with the Bluetooth module while the button was pushed. If a connection was communicating with the Bluetooth module while the button was pushed the Bluetooth module will remain in its operating state (discoverable or connectable-only mode) until one of the following occurs:

1. The KRM is powered down.
2. The DSP is reset via the reset button.

3. The Bluetooth module is placed back into discoverable, or connectable-only, mode and then removed from this mode by button push, or timeout, while no connection is communicating with the Bluetooth module.

5.3.3.3 Port B (USB)

The KRM2000™ is provided with a USB module which requires a connection using a type B USB connection to allow for communication with external devices. Each time a connection is made to a new KRM2000™ a driver will have to be downloaded and installed. This driver is used to create a Virtual Com Port (VCP) which allows the connecting device to view the KRM2000™ as a serial port. Generally the operating system of the connecting device will handle the device driver installation and port binding. However it is recommended that prior to connecting to the device the relevant driver be downloaded from this link in order to insure the latest driver is always being used for the required operating system. The most recent drivers are located at the following link and labeled as the Anybus Transport Providers package

<http://www.hms.se/support/support.asp?PID=333&ProductType=Anybus-CompactCom>.

5.3.4 EEPROM

The KRM2000™ receiver contains 256k of internal memory allocated for set point storage. It is important that after every change to either the system or protection, that the user performs an EEPROM write.

5.4 Protection Features

The KRM2000™ receiver contains multiple protection features, and of these protection features some are provided to be configured by the user. This section will describe each feature as well as the programming limits, if available.

5.4.1 Service Fault

The KRM2000™ receiver has the capability of indicating whether an internal hardware and/or software failure has occurred. This will activate a service fault. A service fault will open up the service fault relay contact during this condition. The service fault contact output is operated as a normally closed contact, and will operate upon removal of power from the receiver.

5.4.2 Malfunction

The malfunction indicates when there is a failure within the system itself. This will include loop undervoltage, loop tuning malfunction, radio link error, and loop short circuit failure. When this condition occurs, the malfunction relay contact output will close while the digital output will go high (+24V).

<p>IMPORTANT: THE KRM2000™ RECEIVERS HAVE BEEN CAREFULLY DESIGNED TO NOT ISSUE A “GROUND FAULT” OUTPUT IF ANY SYSTEM PARAMETER IS OUT OF TOLERANCE.</p>
--

THIS IS TO ENSURE THAT FALSE DETECTION/FALSE TRIPPING DOES NOT OCCUR WHICH IS VITAL FOR APPLICATIONS WHERE IT IS IMPARATIVE THAT THE GENERATOR SET DOES NOT SHUT DOWN. BECAUSE OF THIS FEATURE/DESIGN PHILOSOPHY, THE RECEIVERS MAY ON OCCASION ISSUE A “MALFUNCTION”. THERE IS NO NEED TO SHUTDOWN OR BE ALARMED WITH THIS CONDITION. THIS IS ONLY TO ALERT THE USER THAT THEY SHOULD MONITOR/CHECK THE GENERATOR SET FOR ABNORMAL OPERATING CONDITIONS OR POTENTIAL KRM SYSTEM ISSUES.

5.4.3 Ground Fault

Ground fault protection can be set up help alarm during a rotor ground fault condition. The programmable element for this feature is the ground fault resistance level (in k Ω). When this condition occurs, the ground fault relay contact will close while the digital output will go low (~0V).

5.4.4 PWM Re-enable Time Limit

PWM signals are utilized from the controller by the inductive loop power amp stage in the receiver. During a detected short circuit condition, the PWM signals are disabled for a period of time before they are re-enabled. The programmable element for this is time (in seconds).

5.4.5 Loop Undervoltage

The loop undervoltage can be set to indicate a malfunction with either the loop driver or induction loop antenna itself. If the loop voltage drops below the configured set point, the transmitter may not have enough power available to operate properly. This failure will activate the malfunction feature. The programmable elements for this fault are the loop undervoltage level (in volts) and time limit (in seconds).

5.4.6 Loop Overcurrent

Loop overcurrent can be set to help protect the loop drivers located in the receiver. This failure will activate the malfunction feature. The programmable element for this fault is the loop overcurrent level (in amps).

5.4.7 Radio Link Error

The receiver has the ability to detect a link error when receiving data from the transmitter. This is done by monitoring the number of bytes that should be received during the receive time. If too many or too little bytes are detected, a radio link error will occur. This failure will activate the malfunction feature.

5.4.8 Diode Fault

Diode fault monitoring is an optional feature that is accomplished through a rotor add-on diode fault detector (DFD) device that monitors the rotating rectifier diodes. Under normal operating conditions, with the rotating diodes and DFD functional, the DFD LED and DFD open-drain output will toggle at about a 1 Hz rate. If the DFD indicates a diode fault, the DFD LED will stay on continuously and the DFD open-drain output will be pulled low. If the DFD is not powered, not installed, or has malfunctioned in some way, the DFD LED will remain off and the DFD open-drain output will be pulled high (+24V).

5.5 *Monitoring Features*

This section describes all of the monitoring features provided in the KRM2000™.

5.5.1 *Data Points*

The KRM2000™ Receiver provides monitoring of the following data points:

- Loop Voltage (V)
- Loop Current (I)
- Loop Frequency (kHz)
- RSSI Level
- Board Temperature (°C)
- PWM Duty Cycle
- Transmitter TX Count
- Ground Fault Resistance (Ohms)
- Generator Field Voltage (V)
- Diode Fault Detector Count
- Low Square Wave Voltage (V)
- High Square Wave Voltage (V)

6 Maintenance

No specific maintenance is required for the KRM2000™ system beyond what is required for the exciter. During exciter maintenance, inspect all wiring between the receiver, transmitter, and inductive loop antenna to verify proper connections are maintained and ensure they are free of corrosion. If replacement of wiring is needed for the rotating transmitter connections, be sure to re-apply a good quality, air drying insulating varnish.

For long term storage of the KRM2000™, it is recommended that it be powered up once per year for no less than one hour. This will ensure the life and help prevent the deterioration of the electrolytic capacitors.

The following table defines the replacement/spare parts:

Table 4 Replacement/Spare Parts

KATO PART NUMBER	GE PART NUMBER (REFERENCY ONLY)	DESCRIPTION
511-00810-00		KRM2000™ Receiver
844-69611-00	373A4740P0003	+24Vdc Power Supply
508-00622-00	373A4740P0004	Power Loop Antenna for GE 6A6, LM6000, 6A8, 7A6, 6FA Kato Exciters
514-13000-99	373A4740P0005	Signal Antenna
508-00622-10	373A4740P0006	Power Loop Antenna for GE 9A5 Kato Exciters
508-00615-00	373A4740P0007	Transmitter
499-00146-68	373A4740P0008	Retrofit Kit for GE 7A6
499-00146-69	373A4740P0009	Retrofit Kit for GE 9A4, 7A7
508-00622-20	373A4740P0010	Power Loop Antenna for GE 9A4 Kato Exciters
499-00146-67	373A4740P0011	Retrofit Kit for GE 6A6, LM6000
558-99489-00	373A4740P1001	Bulk Head Connector
514-06767-00		Coaxial Cable
903-14140-15		Shielded Cable
153-01201-05		Loop Bracket for GE 7A6
153-01201-03		Loop Bracket for GE 6A6, LM6000
153-01201-01		Loop Bracket for GE 6A8
153-01324-02		Loop Bracket for GE 9A4
153-01201-02		Loop Bracket for GE 9A5
508-00632-03		Loop Bracket + Loops & Resonator (7A6)
508-00632-04		Loop Bracket + Loops & Resonator (9A4)
508-00632-01		Loop Bracket + Loops & Resonator (6A8)
508-00247-20		Sensing Filter Module for 9A5 Exciters
508-00247-25		Sensing Filter Kit for 9A5 Exciters (includes 508-00247-20 sensing filter module)
508-00247-88		Capacitor Snubber Module for 6A6/7A6/LM6000
508-00247-89		-88 Snubber w/ Connection Leads 6A6/7A6/LM6000
508-00247-87		Complete Snubber Kit for 6A6/7A6/LM6000 (2 pcs)
840-08001-03		Bluetooth Communication Module
840-08001-02		USB Communication Module

7 Troubleshooting

This section provides the basic troubleshooting detail to follow if any issues occur during operation. It should be noted that not all possible scenarios can be documented here, and if at any point the issue can't be resolved by the detail provided, please consult with the Kato Engineering service department.

Table 5 Troubleshooting Guide

SYMPTOM	CAUSE	SOLUTION
Link Error LED Illuminated	No data is being received from the transmitter	Check inductive loop connections, verify that there is loop voltage (>4Vrms)
		Check radio dipole antenna connections
		Check location of transmitter relative to the inductive power loop
		Re-power the receiver
Loop Fault LED Illuminated	Short circuit between loop antenna pins of terminal block	If Link Error persists, replace transmitter
		Inspect the terminal block for a short
		Disconnect inductive loop antenna leads from KRM2000™ receiver and check resistance between the leads
Ground Fault LED Illuminated	Generator rotor has a ground fault	Check resistance between generator field (-) and ground (disconnect transmitter)
	Ground fault resistance trip level is set too high	Use GUI to monitor and/or change the ground fault resistance trip level
	Transmitter is malfunctioning	Test by placing resistor between generator field (-) and ground, then use GUI to monitor the ground fault resistance value
Diode Fault LED Not Illuminated	Diode fault detector malfunction	Use GUI to look at diode fault detector count 10 second average, if equal to, or below 5 then diode fault detector is malfunctioning. Check connection between diode fault detector and KRM transmitter, check rotating rectifier diodes and replace diode fault detector
Diode Fault LED Illuminated	Diode fault has occurred	Use GUI to look at diode fault detector count 10 second average, if above 60 then diode fault detector is indicating a diode fault. So, check rotating rectifier diodes NOTE: Diode fault LED flashing at a rate of 1 Hz is the normal state of operation when a diode fault detector is connected to the KRM transmitter and no fault is present
Malfunction Digital Output Active (High) and/or Ground Fault Relay Output Active (Closed)	Excessive loop antenna current	Check causes listed for Loop Fault LED Illuminated
	Radio Link Error	Check causes listed for Link Error LED Illuminated
	DSP unable to tune loop antenna	Check connection for open circuit between KRM2000™ receiver and loop antenna
	Loop antenna voltage is too low	Check loop for short circuit between loop antenna and receiver
		Monitor loop antenna voltage and loop under-voltage set point with GUI
	Bad connection between KRM2000™ receiver and external monitoring system	Check connections

	Board Failure (digital output failed high and/or relay output failed closed)	Replace board
Ground Fault Digital Output Active (Low) and/or Ground Fault Relay Output Active (Closed)	See Ground Fault LED Illuminated	See Ground Fault LED Illuminated
	Bad connection between KRM2000™ receiver and external monitoring system	Check connections
	Board Failure (digital output failed low and/or relay output failed closed)	Replace board
Diode Fault Digital Output Not Active (High)	See Diode Fault LED Not Illuminated	See Diode Fault LED Not Illuminated
Diode Fault Digital Output Active (Low)	See Diode Fault LED Illuminated	See Diode Fault LED Illuminated
	Bad connection between KRM2000™ receiver and external monitoring system	Check connections
	Board Failure (digital output failed high)	Replace board

8 Appendix

This section provides instruction and description of many of the optional features of the KRM2000™ as well as procedural instructions as needed.

8.1 *Configure TCP/IP Settings of Communication Modules*

If a KRM2000™ has been ordered with a communication module that supports Ethernet communications (Ethernet/IP, BACnet/IP, EtherCAT, Modbus TCP, Powerlink, Profinet, Sercos III) more times than not a static IP address will be required. As the module comes defaulted with DHCP enabled in order to configure this Anybus provides a tool to configure the IP Address and other network components of the module. This section will go through the steps for configuring these devices.

In this example we will show how to configure an Ethernet/IP Module.

1. Go to the following link and download the latest “Anybus IPconfig – Utility for module TCP/IP configuration.”
<http://www.anybus.com/support/support.asp?PID=509&ProductType=Support%20Tools>.

2. Ensure that you are on the same LAN as the connected module and start the Anybus IPconfig utility and press the “Scan” button. The Anybus modules connected to the network will now appear in the window as shown in the figure below.

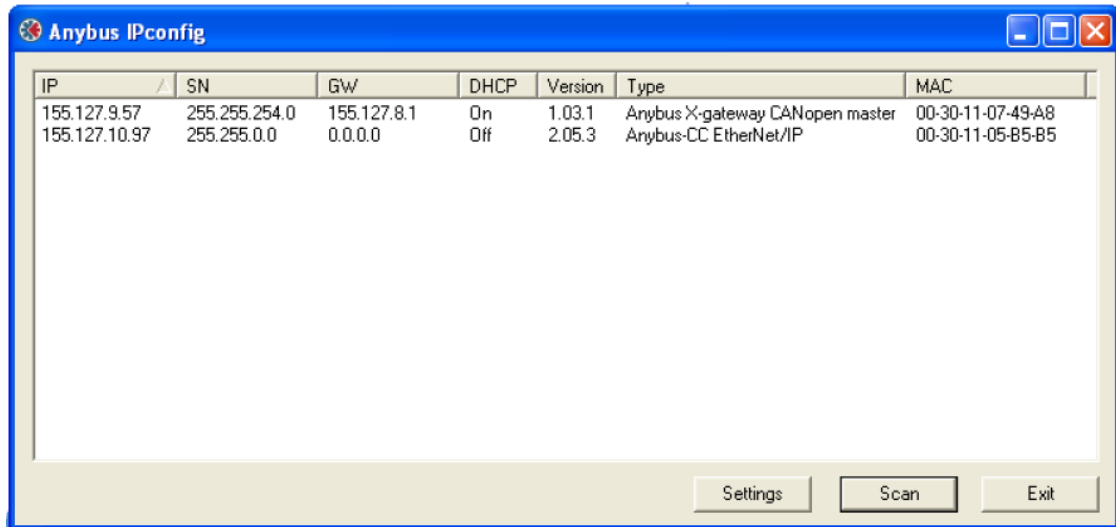

3.

Figure 22 Anybus IPConfig Scan Example

4. In this example we want to modify the settings of the module which “Type” is described as “Anybus-CC Ethernet/IP”. Double click on the module. The window shown in the below figure should appear.

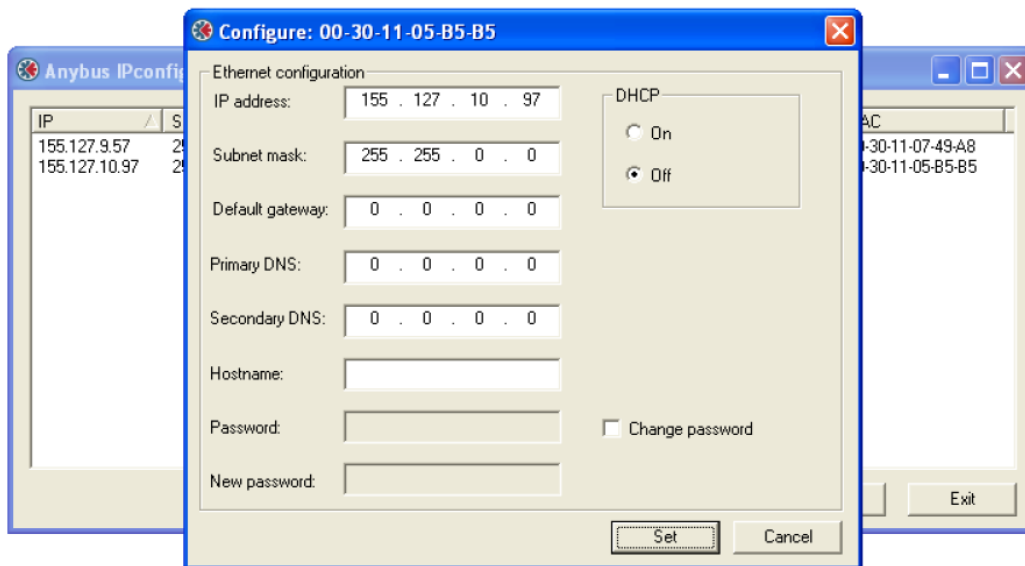

Figure 23 TCP/IP Configurable Settings

5. Configure the module to the settings required for your application. Pressing the “Set” button stores these settings in the module itself so that they are retained in non-volatile memory.

8.2 Ethernet/IP

The KRM2000™ is capable of being integrated to an Ethernet/IP network which allows for monitoring data by a Programmable Logic Controller (PLC) or other Distributed Control System (DCS) when an Ethernet/IP module is ordered with the KRM2000™. For specific information to other CIP objects available with the Ethernet/IP module please refer to the specific module documentation available at <http://www.anybus.com/>.

8.2.1 CIP Object Dictionary

The CIP object where KRM2000™ data is available is object 162 (0xA2). All messages should be sent to this object referencing the desired instance of which the data will come in accordance with the below CIP Instance Attribute Model table provided below.

Each object instance will have attributes in accordance with the below table.

Table 6 CIP Instance Attributes Model

Attribute	Name	Access	Type	Description
1	Name	Get	String	Parameter Name
2	Data Type	Get	8 Bit Integer	Data type of instance value
3	No. of elements	Get	8 Bit Integer	Number of elements of the specified data type
4	Access Descriptor	Get	8 Bit Integer	Bit : Value = Meaning 0 : 1 = Get Access 1 : 1 = Set Access
5	Value	Get/Set	Determined by attribute 2	Instance value
6	Max value	Get	Determined by attribute 2	The maximum permitted parameter value
7	Min value	Get	Determined by attribute 2	The minimum permitted parameter value
8	Default value	Get	Determined by attribute 2	The default parameter value

Use the below table for reference of all the data available via Ethernet/IP on the KRM2000™.

Table 7 Ethernet/IP CIP Object Dictionary

Instance	Attribute	Value
1	Name	General Control Reg 1
	Data Type	Unsigned 32 bit integer
	No. of elements	1
	Access Descriptor	Get/Set
	Value	-
	Max value	4294967295
	Min value	0
	Default value	0
2	Name	General Control Reg 2
	Data Type	Unsigned 32 bit integer
	No. of elements	1
	Access Descriptor	Get/Set
	Value	-
	Max value	4294967295

	Min value	0
	Default value	0
3	Name	Gnd Fit Trip Count
	Data Type	Unsigned 32 bit integer
	No. of elements	1
	Access Descriptor	Get/Set
	Value	-
	Max value	100
	Min value	0
	Default value	0
4	Name	Trip Zone Count
	Data Type	Unsigned 32 bit integer
	No. of elements	1
	Access Descriptor	Get/Set
	Value	-
	Max value	100
	Min value	1
	Default value	0
5	Name	Trip Zone Retry Count
	Data Type	Unsigned 32 bit integer
	No. of elements	1
	Access Descriptor	Get/Set
	Value	-
	Max value	100
	Min value	1
	Default value	0
5	Name	Reserved
	Data Type	-
	No. of elements	-
	Access Descriptor	-
	Value	-
	Max value	-
	Min value	-
	Default value	-
6	Name	Reserved
	Data Type	-
	No. of elements	-
	Access Descriptor	-
	Value	-
	Max value	-
	Min value	-
	Default value	-
7	Name	Reserved
	Data Type	-
	No. of elements	-
	Access Descriptor	-
	Value	-
	Max value	-
	Min value	-
	Default value	-

8	Name	Reserved
	Data Type	-
	No. of elements	-
	Access Descriptor	-
	Value	-
	Max value	-
	Min value	-
	Default value	-
9	Name	Reserved
	Data Type	-
	No. of elements	-
	Access Descriptor	-
	Value	-
	Max value	-
	Min value	-
	Default value	-
10	Name	Gnd Flt Trip Lvl (Kohms)
	Data Type	Float
	No. of elements	1
	Access Descriptor	Get/Set
	Value	-
	Max value	10000.0
	Min value	1.0
	Default value	1.0
11	Name	Loop Tuning Step Size
	Data Type	Float
	No. of elements	1
	Access Descriptor	Get/Set
	Value	-
	Max value	100.00
	Min value	0.00001
	Default value	0.0
12	Name	Trip Zone Re-enable Time
	Data Type	Float
	No. of elements	1
	Access Descriptor	Get/Set
	Value	-
	Max value	100.00
	Min value	0.05
	Default value	0.05
13	Name	Loop Under Voltage Mal.
	Data Type	Float
	No. of elements	1
	Access Descriptor	Get/Set
	Value	-
	Max value	24.0
	Min value	1.0
	Default value	0.0
14	Name	Loop Under Voltage Time Lim
	Data Type	Float

	No. of elements	1
	Access Descriptor	Get/Set
	Value	-
	Max value	60.0
	Min value	0.1
	Default value	0.1
15	Name	Loop Current Fault (Amps)
	Data Type	Float
	No. of elements	1
	Access Descriptor	Get/Set
	Value	-
	Max value	20.0
	Min value	0.1
	Default value	0.1
16	Name	Reserved
	Data Type	-
	No. of elements	-
	Access Descriptor	-
	Value	-
	Max value	-
	Min value	-
	Default value	-
17	Name	Reserved
	Data Type	-
	No. of elements	-
	Access Descriptor	-
	Value	-
	Max value	-
	Min value	-
	Default value	-
18	Name	Reserved
	Data Type	-
	No. of elements	-
	Access Descriptor	-
	Value	-
	Max value	-
	Min value	-
	Default value	-
19	Name	Reserved
	Data Type	-
	No. of elements	-
	Access Descriptor	-
	Value	-
	Max value	-
	Min value	-
	Default value	-
20	Name	Loop Voltage
	Data Type	Float
	No. of elements	1
	Access Descriptor	Get

	Value	-
	Max value	30.0
	Min value	0.0
	Default value	0.0
21	Name	Loop Current
	Data Type	Float
	No. of elements	1
	Access Descriptor	Get
	Value	-
	Max value	30.0
	Min value	0.0
	Default value	0.0
22	Name	Linx RSSI Level (V)
	Data Type	Float
	No. of elements	1
	Access Descriptor	Get
	Value	-
	Max value	3.3
	Min value	0.0
	Default value	0.0
23	Name	Board Temp (C)
	Data Type	Float
	No. of elements	1
	Access Descriptor	Get
	Value	-
	Max value	125.0
	Min value	0.0
	Default value	0.0
24	Name	PWM Duty Cycle
	Data Type	Float
	No. of elements	1
	Access Descriptor	Get
	Value	-
	Max value	100.0
	Min value	0.0
	Default value	0.0
25	Name	Loop Frequency (KHz)
	Data Type	Float
	No. of elements	1
	Access Descriptor	Get
	Value	-
	Max value	150.0
	Min value	0.0
	Default value	0.0
26	Name	Transmitter Tx Count
	Data Type	Unsigned 16 bit integer
	No. of elements	1
	Access Descriptor	Get
	Value	-
	Max value	65535

	Min value	0
	Default value	0
27	Name	Ground Fault Resistance (Kohms)
	Data Type	Unsigned 16 bit integer
	No. of elements	1
	Access Descriptor	Get
	Value	-
	Max value	65535
	Min value	0
	Default value	0
28	Name	Generator Field Voltage
	Data Type	Unsigned 16 bit integer
	No. of elements	1
	Access Descriptor	Get
	Value	-
	Max value	65535
	Min value	0
	Default value	0
29	Name	Diode Fault Detector Count
	Data Type	Unsigned 16 bit integer
	No. of elements	1
	Access Descriptor	Get
	Value	-
	Max value	65535
	Min value	0
	Default value	0
30	Name	Low Square Wave Voltage
	Data Type	Unsigned 16 bit integer
	No. of elements	1
	Access Descriptor	Get
	Value	-
	Max value	65535
	Min value	0
	Default value	0
31	Name	High Square Wave Voltage
	Data Type	Unsigned 16 bit integer
	No. of elements	1
	Access Descriptor	Get
	Value	-
	Max value	65535
	Min value	0
	Default value	0
32	Name	Reserved
	Data Type	-
	No. of elements	-
	Access Descriptor	-
	Value	-
	Max value	-
	Min value	-
	Default value	-

33	Name	Reserved
	Data Type	-
	No. of elements	-
	Access Descriptor	-
	Value	-
	Max value	-
	Min value	-
	Default value	-
34	Name	Reserved
	Data Type	-
	No. of elements	-
	Access Descriptor	-
	Value	-
	Max value	-
	Min value	-
	Default value	-
35	Name	GPIO A0 Test Mode Enable
	Data Type	Unsigned 32 bit integer
	No. of elements	1
	Access Descriptor	Get/Set
	Value	-
	Max value	4294967295
	Min value	0
	Default value	0
36	Name	GPIO A1 Test Mode Enable
	Data Type	Unsigned 32 bit integer
	No. of elements	1
	Access Descriptor	Get/Set
	Value	-
	Max value	4294967295
	Min value	0
	Default value	0
37	Name	GPIO B0 Test Mode Enable
	Data Type	Unsigned 32 bit integer
	No. of elements	1
	Access Descriptor	Get/Set
	Value	-
	Max value	4294967295
	Min value	0
	Default value	0
38	Name	GPIO B1 Test Mode Enable
	Data Type	Unsigned 32 bit integer
	No. of elements	1
	Access Descriptor	Get/Set
	Value	-
	Max value	4294967295
	Min value	0
	Default value	0
39	Name	GPIO C0 Test Mode Enable
	Data Type	Unsigned 32 bit integer

	No. of elements	1
	Access Descriptor	Get/Set
	Value	-
	Max value	4294967295
	Min value	0
	Default value	0
40	Name	GPIO C1 Test Mode Enable
	Data Type	Unsigned 32 bit integer
	No. of elements	1
	Access Descriptor	Get/Set
	Value	-
	Max value	4294967295
	Min value	0
	Default value	0
41	Name	GPIO A0 Test Mode Data
	Data Type	Unsigned 32 bit integer
	No. of elements	1
	Access Descriptor	Get/Set
	Value	-
	Max value	4294967295
	Min value	0
	Default value	0
42	Name	GPIO A1 Test Mode Data
	Data Type	Unsigned 32 bit integer
	No. of elements	1
	Access Descriptor	Get/Set
	Value	-
	Max value	4294967295
	Min value	0
	Default value	0
43	Name	GPIO B0 Test Mode Data
	Data Type	Unsigned 32 bit integer
	No. of elements	1
	Access Descriptor	Get/Set
	Value	-
	Max value	4294967295
	Min value	0
	Default value	0
44	Name	GPIO B1 Test Mode Data
	Data Type	Unsigned 32 bit integer
	No. of elements	1
	Access Descriptor	Get/Set
	Value	-
	Max value	4294967295
	Min value	0
	Default value	0
45	Name	GPIO C0 Test Mode Data
	Data Type	Unsigned 32 bit integer
	No. of elements	1
	Access Descriptor	Get/Set

	Value	-
	Max value	4294967295
	Min value	0
	Default value	0
46	Name	GPIO C1 Test Mode Data
	Data Type	Unsigned 32 bit integer
	No. of elements	1
	Access Descriptor	Get/Set
	Value	-
	Max value	4294967295
	Min value	0
	Default value	0
47	Name	GPIO A0 Test Display Data
	Data Type	Unsigned 32 bit integer
	No. of elements	1
	Access Descriptor	Get/Set
	Value	-
	Max value	4294967295
	Min value	0
	Default value	0
48	Name	GPIO A1 Test Display Data
	Data Type	Unsigned 32 bit integer
	No. of elements	1
	Access Descriptor	Get/Set
	Value	-
	Max value	4294967295
	Min value	0
	Default value	0
49	Name	GPIO B0 Test Display Data
	Data Type	Unsigned 32 bit integer
	No. of elements	1
	Access Descriptor	Get/Set
	Value	-
	Max value	4294967295
	Min value	0
	Default value	0
50	Name	GPIO B1 Test Display Data
	Data Type	Unsigned 32 bit integer
	No. of elements	1
	Access Descriptor	Get/Set
	Value	-
	Max value	4294967295
	Min value	0
	Default value	0
51	Name	GPIO C0 Test Display Data
	Data Type	Unsigned 32 bit integer
	No. of elements	1
	Access Descriptor	Get/Set
	Value	-
	Max value	4294967295

	Min value	0
	Default value	0
52	Name	GPIO C1 Test Display Data
	Data Type	Unsigned 32 bit integer
	No. of elements	1
	Access Descriptor	Get/Set
	Value	-
	Max value	4294967295
	Min value	0
	Default value	0
53	Name	Reserved
	Data Type	-
	No. of elements	-
	Access Descriptor	-
	Value	-
	Max value	-
	Min value	-
	Default value	-
54	Name	Reserved
	Data Type	-
	No. of elements	-
	Access Descriptor	-
	Value	-
	Max value	-
	Min value	-
	Default value	-
55	Name	Product ID
	Data Type	Unsigned 32 bit integer
	No. of elements	1
	Access Descriptor	Get
	Value	-
	Max value	10
	Min value	1
	Default value	4
56	Name	DSP Uptime
	Data Type	Unsigned 32 bit integer
	No. of elements	1
	Access Descriptor	Get
	Value	-
	Max value	4294967295
	Min value	0
	Default value	0
57	Name	DSP Reboot Count
	Data Type	Unsigned 32 bit integer
	No. of elements	1
	Access Descriptor	Get
	Value	-
	Max value	4294967295
	Min value	0
	Default value	0

58	Name	Anybus Control Register
	Data Type	Unsigned 32 bit integer
	No. of elements	1
	Access Descriptor	Get
	Value	-
	Max value	4294967295
	Min value	0
	Default value	0
59	Name	Connected Port
	Data Type	Unsigned 16 bit integer
	No. of elements	1
	Access Descriptor	Get
	Value	-
	Max value	65535
	Min value	0
	Default value	0
60	Name	DSP Software Version
	Data Type	Unsigned 32 bit integer
	No. of elements	1
	Access Descriptor	Get
	Value	-
	Max value	4294967295
	Min value	0
	Default value	0
61	Name	Hardware Serial Number
	Data Type	Character (String)
	No. of elements	10
	Access Descriptor	Get
	Value	-
	Max value	255 (0xFF)
	Min value	0
	Default value	'0'
62	Name	Hardware Part Number
	Data Type	Character (String)
	No. of elements	12
	Access Descriptor	Get
	Value	-
	Max value	255 (0xFF)
	Min value	0
	Default value	-
63	Name	Hardware Revision
	Data Type	Character (String)
	No. of elements	1
	Access Descriptor	Get
	Value	-
	Max value	255 (0xFF)
	Min value	0
	Default value	'.'
64	Name	Software Part Number
	Data Type	Character (String)
	No. of elements	12

	Access Descriptor	Get
	Value	-
	Max value	255 (0xFF)
	Min value	0
	Default value	'.'
65	Name	DSP Software Revision
	Data Type	Character (String)
	No. of elements	5
	Access Descriptor	Get
	Value	-
	Max value	255 (0xFF)
	Min value	0
	Default value	'.'
66	Name	Part Numbers
	Data Type	Character (String)
	No. of elements	40 (See applicable table key)
	Access Descriptor	Get
	Value	-
	Max value	255 (0xFF)
	Min value	0
	Default value	'.'
67	Name	Op_vars Uint32 Min/Max Data
	Data Type	Unsigned 32 bit integer
	No. of elements	20 (See applicable table key)
	Access Descriptor	Get
	Value	-
	Max value	4294967295
	Min value	0
	Default value	0
68	Name	Op_vars float Min/Max Data
	Data Type	Float
	No. of elements	20 (See applicable table key)
	Access Descriptor	Get
	Value	-
	Max value	4294967295
	Min value	0
	Default value	0
69	Name	Gen vars Test En Min/Max
	Data Type	Unsigned 32 bit integer
	No. of elements	22 (See applicable table key)
	Access Descriptor	Get
	Value	-
	Max value	4294967295
	Min value	0
	Default value	0
70	Name	Gen vars Test Data Min/Max
	Data Type	Unsigned 32 bit integer
	No. of elements	22 (See applicable table key)
	Access Descriptor	Get
	Value	-

Max value	4294967295
Min value	0
Default value	0

Table 8 General Control Register

Bit	Name	Description	Default
1	Rsvd	N/A	N/A
2	External Filter Present	40Kohm external filter is present on the rotor.	0
3	Reset to Defaults	Reset KRM2000™ set points to the factory defaults.	0
4	Rsvd	N/A	N/A
5	Tune loop voltage	Tune loop antenna for maximum loop voltage. Set to 0 to tune for minimum loop current.	1
6	Mini Sweep Tuning Method	Tune loop antenna via “mini-sweep” method. Set to 0 to use Loop Tuning Step Size to continuously modify loop frequency.	0

8.3 Data Tables

This section provides an index of what values are available in the different data tables available over the network interface.

Table 9 Part Numbers Table Index

Part Numbers Table
Hardware Serial Number
Hardware Part Number
Hardware Revision
Software Part Number
DSP Software Revision

Table 10 Unsigned 32 Bit Integer Min/Max Value Table

Op_vars Uint32 Min/Max Data Table
General Control Reg 1 Max
General Control Reg 1 Min
General Control Reg 2 Max
General Control Reg 2 Min
Gnd Flt Trip Count Max
Gnd Flt Trip Count Min
Trip Zone Count Max
Trip Zone Count Min
Trip Zone Retry Count Max
Trip Zone Retry Count Min

Table 11 Floating Point Min/Max Value Table

Op_vars float Min/Max Data Table
Gnd Flt Trip Lvl (Kohms) Max
Gnd Flt Trip Lvl (Kohms) Min
Loop Tuning Step Size Max
Loop Tuning Step Size Min
Trip Zone Re-enable Time Max
Trip Zone Re-enable Time Min
Loop Under Voltage Mal. Max
Loop Under Voltage Mal. Min
Loop Under Voltage Time Lim Max
Loop Under Voltage Time Lim Min

Table 12 GPIO Test Mode Enable Min/Max Table

Gen vars Test En Min/Max Data Table
GPIO A0 Test Mode Enable Max
GPIO A0 Test Mode Enable Min
GPIO A1 Test Mode Enable Max
GPIO A1 Test Mode Enable Min
GPIO B0 Test Mode Enable Max
GPIO B0 Test Mode Enable Min
GPIO B1 Test Mode Enable Max
GPIO B1 Test Mode Enable Min
GPIO C0 Test Mode Enable Max
GPIO C0 Test Mode Enable Min
GPIO C1 Test Mode Enable Max
GPIO C1 Test Mode Enable Min

Table 13 GPIO Test Mode Data Min/Max Table

Gen vars Test Data Min/Max Data Table
GPIO A0 Test Mode Data Max
GPIO A0 Test Mode Data Min
GPIO A1 Test Mode Data Max
GPIO A1 Test Mode Data Min
GPIO B0 Test Mode Data Max
GPIO B0 Test Mode Data Min
GPIO B1 Test Mode Data Max
GPIO B1 Test Mode Data Min
GPIO C0 Test Mode Data Max
GPIO C0 Test Mode Data Min
GPIO C1 Test Mode Data Max
GPIO C1 Test Mode Data Min

8.4 Flash Programming Updates

The KRM2000™ receiver can be updated through the front USB port utilizing a cable with a type A connector. Refer to section 5.3.3 for the latest driver updates.

Open up C2Prog.exe, which can be downloaded from <http://www.codeskin.com/programmer>. Once opened, select the appropriate .hex file, as shown below.

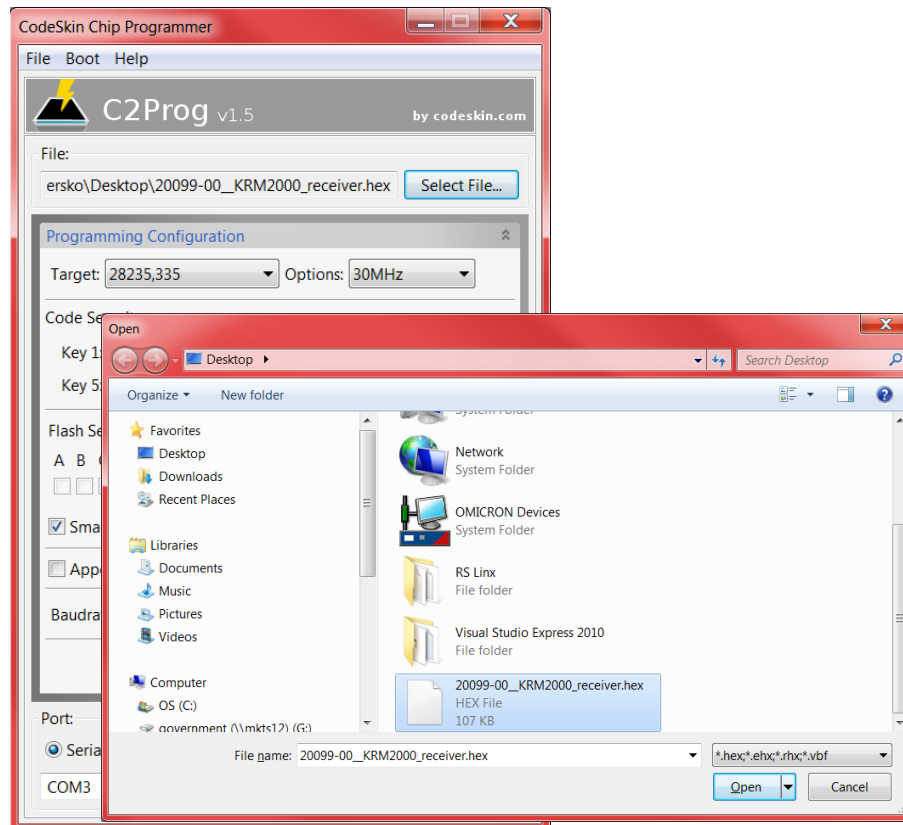

Figure 24 Flash File Selection

Set the *Target* to “28235,335” and for *Options*, select 30MHz. Connect the USB cable to the front port. Properly configure the port to the one that is connected to the receiver. Once the port has been properly configured, press the ‘Reset’ button on the front of the receiver. This will put the receiver into a reset mode. Select Program and the boot loader will begin downloading the firmware. Once the download is complete, disconnect the USB cable and reboot the receiver.

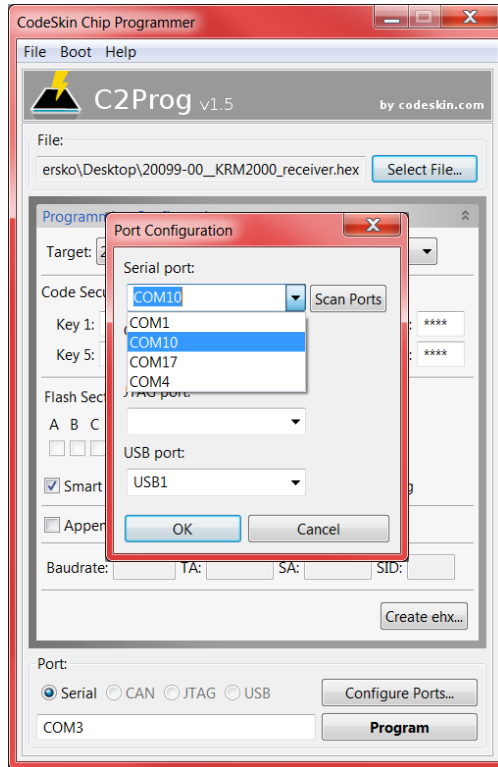

Figure 25 Flash Port Configuration

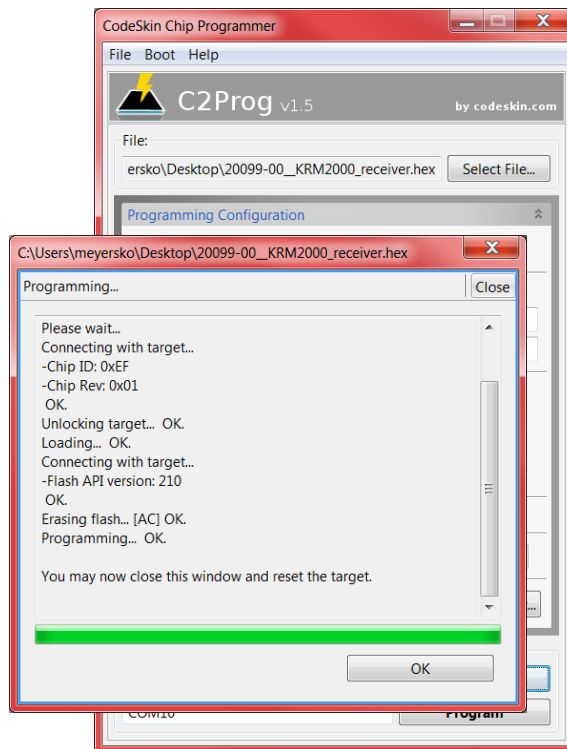

Figure 26 Flash Download Window

8.5 Sensing Filter Option

For special legacy products, such as the 9A5 exciter, a sensing filter is required for the transmitter. This sensing filter helps mitigate high voltage spikes that can be seen in certain applications. The figure below demonstrates the wiring of the sensing filter to the transmitter. When utilizing the sensing filter, a 40k Ω offset needs to be set in the receiver.

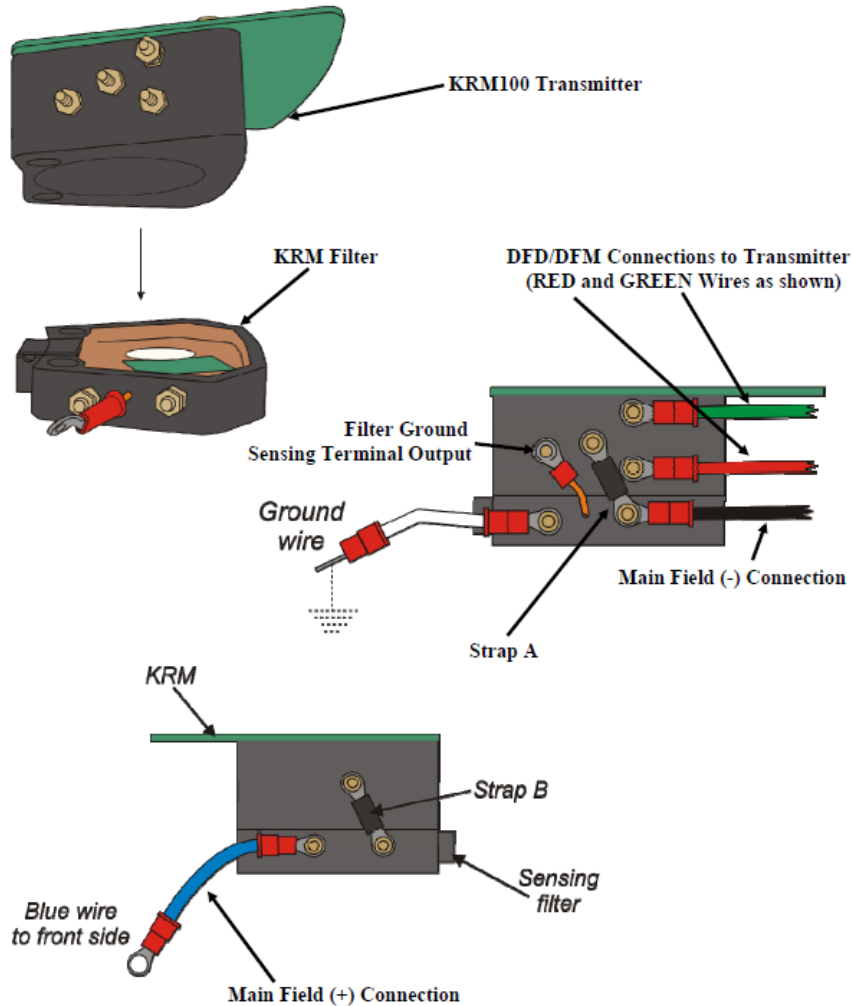

Figure 27 Sensing Filter Wiring/Installation Detail