

Instruction Manual

Installation
Operation
Maintenance

Voltage Regulator
KCR 760

Publication
351-01002-00A (09/23/2005)



Nidec
KATO ENGINEERING™

Kato Engineering, Inc. | P.O. Box 8447 | Mankato, MN USA 56002-8447 | Tel: 507-625-4011
KatoEngineering@mail.nidec.com | www.KatoEngineering.com | Fax: 507-345-2798

Table of Contents

Note: Because of rapid changes in designs and processes and the variability of Kato Engineering's products, information in this manual must not be regarded as binding and is subject to change without notice.

Introduction.....	4
Foreword.....	4
Safety instructions.....	4
Ratings/description.....	4
Features, options and specifications.....	4
Overview.....	4
Standard features and options.....	5
Specifications.....	7
Operating principles.....	10
Installation.....	16
Mounting.....	16
Interconnection.....	16
Single phase 100 to 600 Vac sensing.....	16
Three-phase 100 to 600 Vac sensing.....	16
Input power.....	20
Output power.....	20
Grounding.....	20
External voltage adjust rheostat.....	20
Connection to reactive voltage droop.....	21
UFL circuit 50/60 and 400 Hz selector J1.....	25
Voltage regulator fuse.....	25
Accessory items.....	25
Operation.....	30
Adjustments.....	30
Field flashing.....	30
Single unit initial operation.....	32
Parallel operation.....	34
Maintenance.....	37
Preventive maintenance.....	37
Corrective maintenance.....	37
Operational test.....	38
Troubleshooting.....	38

Figures and Tables

Figure 1: Standard UFL operational threshold for 50/60 Hz system.....	9
Figure 2: Effect of timed gating signal on SCR phase angle.....	13
Figure 3: Outline drawing.....	17
Figure 4: Single phase sensing schematic.....	18
Figure 5: Three-phase sensing schematic.....	19
Figure 6: Interconnection.....	22
Figure 7: Parallel operation, reactive voltage droop mode.....	23
Figure 8: Parallel operation, cross-current compensation mode.....	24
Figure 9: Circuit board schematic (with UFL or volts-per-Hz).....	26
Figure 10: Circuit board schematic (with flat regulation option).....	27
Figure 11: UFL electrical schematic.....	28
Figure 12: Operational test.....	39
Table 1: Voltage across under frequency limit terminals TP1-TP2, 60 Hz..	31
Table 2: Voltage across under frequency limit terminals TP1-TP2, 50 Hz..	31
Table 3: Replacement parts list.....	37
Table 4: Troubleshooting.....	40

Introduction

Foreword

This manual contains instructions for installing, operating and maintaining Kato Engineering KCR 760 voltage regulators.

Please read this manual in its entirety before installing, operating, and servicing your regulator.

Safety instructions

In order to prevent injury or equipment damage, everyone involved in installation, operating and maintenance of the equipment described in this manual must be qualified and informed of the current safety standards that govern his or her work.

While “common-sense” prevention of injury or equipment damage cannot be completely defined by any manual (nor built into any piece of equipment), the following paragraphs define warnings, cautions, and notes as they are used in this manual:

Warning: Warnings identify an installation, operating or maintenance procedure, practice, condition, or statement that, if not strictly followed, could result in death or serious injury to personnel.

Caution: Cautions identify an installation, operating or maintenance procedure, practice, condition, or statement that, if not strictly followed, could result in destruction of or damage to equipment or serious impairment of system operation.

Note: Notes highlight an installation, operating or maintenance procedure, condition, or statement and are essential or helpful but are not of known hazardous nature as indicated by warnings and cautions.

Features options and specifications

Overview

The KCR 760 voltage regulator is designed for operation with brushless synchronous generators. The voltage regulator controls generator voltage by regulating the amount of current it supplies the exciter field.

The KCR 760 voltage regulator consists of transformers, transistors, silicon diodes, silicon controlled rectifiers (SCRs), integrated circuits, resistors, and capacitors. The regulators is relatively unaffected by humidity, temperature, vibration, or shock and is not subject to wear from moving parts. Solid-state field flashing components rather than relays are used in the field flashing and underfrequency circuits, eliminating the possibility of contact arcing or contact failure.

Standard features and options

Features provided in standard KCR 760 voltage regulators, options available in this series, and various accessories that can be supplied with the generator set voltage regulating system are described in the paragraphs that follow. Where options are specified in the purchase order, the required circuitry changes are made within the regulator at the factory while accessories are parts that mount external to the regulator.

Standard sensing: The basic KCR 760 regulator uses single phase 50/60 Hz sensing. The sensing transformer has a multi-tap primary permitting operation at sensing voltages of 100 to 600 Vac. The standard regulator includes an underfrequency limit circuit that decreases voltage in proportion to the decrease in frequency when speed drops below the UFL operational threshold. The UFL in standard 50/60 Hz sensing regulators is adjusted with an operational threshold of 48 Hz for a 50 Hz application and 58 Hz for a 60 Hz application.

Optional sensing: When specified in the purchase order the regulator can be supplied with the following variations in sensing circuitry:

- Three phase 50/60 Hz, 100 to 600 Vac sensing.
- UFL set 49.5/59.5 Hz for use with turbocharged engines.
- Volts-per-hertz circuitry in place of UFL for applications where voltage must be proportional to frequency over a speed range from rated rpm down to approximately 1/2 rated speed.
- 400 Hz, single or three-phase, 100 to 600 Vac with 385 Hz UFL operational threshold.
- 400 Hz with UFL threshold higher or lower than 385 Hz.
- 50/60 Hz or 400 Hz, single or three-phase 100 to 600 Vac with flat regulation for a motor-generator set or variable frequency/constant voltage applications. Regulators with flat regulation will not include UFL or V/Hz circuitry.

Standard input power and dc output: Standard KCR 760 regulator uses single-phase, 120 Vac $\pm 10\%$ input power and has rated maximum continuous output of 65 Vdc, 10 A; 90 Vdc, 15 A one-minute field forcing.

Optional input power and dc output: When specified in the purchase order, the KCR 760 regulator may be modified to operate from single phase, 240 Vac $\pm 10\%$ input power and thereby have rated maximum continuous output of 125 Vdc, 10 A; 180 Vdc, 15 A one-minute field forcing.

Field flashing: KCR 760 voltage regulators include solid-state field flashing circuitry.

Standard fuse: Standard KCR 760 regulators are supplied with a 15 A normal blow fuse in the input power circuitry within the regulator. This fuse provides voltage regulator overload protection.

Optional fuse: In applications where the system does not include a field circuit breaker and generator field protection is required, a smaller fuse may be used. For generator field protection, fuse amperage should be one and a half to two times the exciter field current with rated load connected to the generator. Fuse amperage must not exceed 15 A or two thirds open circuit forcing. The fuse must be normal blow type. Do not install a time-delay type fuse.

Standard voltage adjust: KCR 760 voltage regulators are provided with an internal voltage range adjust potentiometer and an auto voltage adjust rheostat for remote mounting. The auto voltage adjust rheostat permits adjustment of generator voltage approximately $\pm 10\%$ from the nominal sensing voltage.

Wide-range voltage adjust: For applications where voltage must be adjusted more than $\pm 10\%$ from nominal, wide range voltage adjust circuitry can be provided with the generator set. This accessory is designed for remote mounting and is electrically connected between the generator sensing lines and the regulator sensing terminals.

Parallel operation components: KCR 760 voltage regulators include a parallel operation reactive voltage droop transformer (T2) and a parallel voltage droop potentiometer (R4). For parallel operation each generator must be equipped with a current transformer for sensing reactive current. The transformer may have either a 1 A or 5 A secondary. When a 1 A current transformer is used, the secondary leads connect to regulator terminals CT• and CT1. When a 5 A current transformer is used, the secondary connects to regulator terminals CT• and CT5.

Electromagnetic interference filters: When specified in the purchase order the KCR 760 regulator can be supplied with EMI filters as an external accessory.

Input power load isolation or voltage matching transformers: Load isolation and voltage matching transformers are accessory items that mount external to the voltage regulator. Load isolation transformers are available with 120 V primary/120 V secondary (for use with standard 120 Vac input power voltage regulators), or 240 Vac primary/240 Vac secondary (for use with 240 Vac input power regulators). Load isolation transformers are recommended for any application where frequency of the input power to the regulator is different from the sensing frequency,

such as 400 Hz motor-generator applications where regulator input power is taken from 50/60 Hz motor-generator set input power lines. Voltage matching transformers are available for applications where available voltage is different from the voltage regulator rated input voltage.

Field circuit breaker: When specified in the purchase order, the generating system can be provided with a field circuit breaker for generator field protection.

Voltage shutdown switch: When specified in the purchase order, the generating system can be supplied with a switch that electrically connects in the line that supplies input power to the regulator. This protective device is recommended for engine driven generator applications not provided with field circuit breaker or underfrequency protection.

Automatic/manual voltage control: When specified in the purchase order, the generating system can be supplied with an automatic/manual voltage control module. This accessory includes a full wave rectifier and a variable transformer (variac) for manual voltage control and a three-position switch. The switch allows the generator to be controlled either automatically by the voltage regulator or manually. The OFF position provides voltage shut-down by de-energizing both the voltage regulator and the manual voltage control rectifier.

Specifications

Power output:

- 65 Vdc, 10 A; maximum continuous output; 90 Vdc, 15 A one-minute field forcing where the regulator is constructed for 120 Vac input.
- 125 Vdc, 10 A; maximum continuous output; 180 Vdc, 15 A one-minute field forcing where the regulator is constructed for 240 Vac input.

Power input: Single phase, 50/60 Hz, 120 Vac $\pm 10\%$; or single phase, 50/60 Hz, 240 Vac $\pm 10\%$.

Sensing: Standard regulators are constructed for single phase 100 Vac to 600 Vac sensing. Three phase 100 Vac to 600 Vac available as optional feature. Special voltage or frequency is available as an optional feature. V/Hz sensing available as optional feature.

Voltage adjustment range: $\pm 10\%$ is standard. Wide-range voltage adjust is available as an optional accessory.

Field resistance:

- 6.5 Ω minimum, 100 Ω maximum for a standard 65 Vdc regulator.
- 12.5 Ω minimum, 200 Ω maximum for an optional 125 Vdc regulator.

Burden resistance: Sensing: 6 VA maximum. Input power: 2400 VA maximum for 240 Vac input; 1200 VA maximum for 120 Vac input. Paralleling: 10 VA maximum.

Paralleling: 1 A for 6% droop or 5 A for 6% droop on current transformer. For 1 A, connect to terminals CT• common and CT1; for 5 A connect to terminal CT• common and CT5. Factory adjusted 4% droop.

Fuse: 15 A maximum, ABC type fuse for voltage regulator protection.

Underfrequency protection: Except where flat regulation, V/Hz sensing or UFL with special operational threshold is specified in the purchase order, the underfrequency limit (UFL) circuit will provide underfrequency protection by reducing voltage in proportion to frequency. The UFL operational threshold where limiting starts is as follows (see also Figure 1):

- Standard:
 - 58 Hz for 60 Hz system
 - 48 Hz for 50 Hz system
 - 385 Hz for 400 Hz system
- Optional for use with generator driven by turbocharged engine:
 - 59.5 Hz for 60 Hz system
 - 49.5 Hz for 50 Hz system
 - 395 Hz for 400 Hz system

Regulator accuracy: Voltage regulation is maintained within $\pm 0.5\%$ over full range of generator loading and for generator speed variations of up to 5%.

Regulator response: Less than 17 milliseconds.

Thermal stability: Less than ± 0.5 percent for 40° change in ambient temperature.

Operating temperature: -40° C to 60° C.

Storage temperature: -60° C to +85° C.

Power dissipation: Less than 35 W at maximum continuous rating during single generator operation; less than 45 W at maximum continuous rating during parallel generator operation.

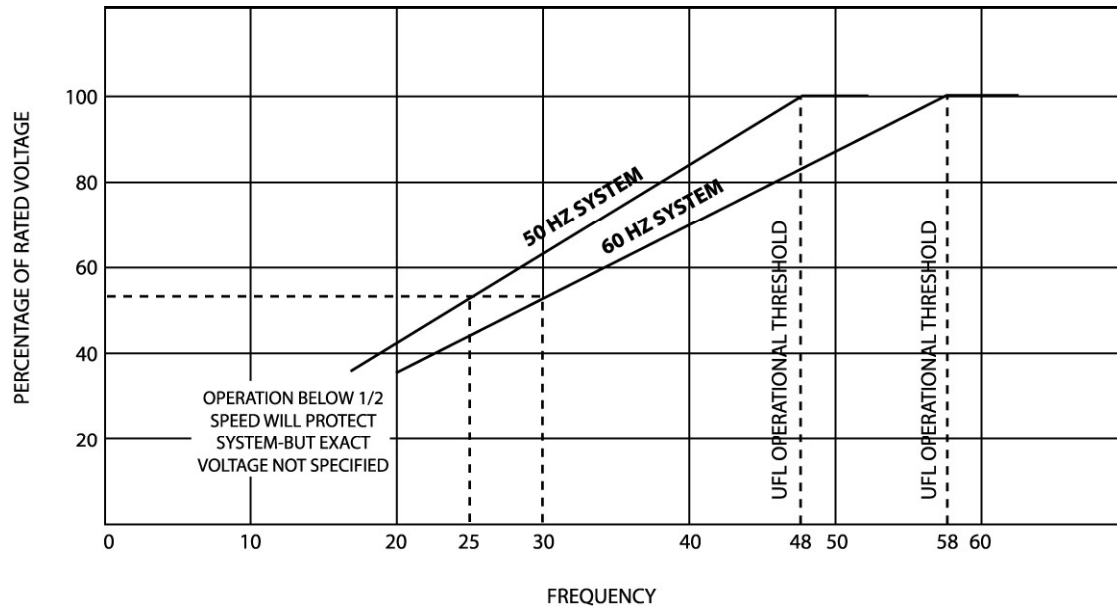

Figure 1: Standard UFL operational threshold for 50/60 Hz system

Shock: Tested to withstand up to 20 gs in each axis.

Vibration: Tested to withstand 1.2 gs from 6 to 26 Hz; 0.32 in. double amplitude from 26 to 52 Hz; 5 gs from 53 to 150 Hz.

Construction: Steel chassis with welded seams; zinc plated according to specification QQ-2-325, Type 11, Class 2; circuit board is silicon resin conformal coated.

Dimensions: 11.5 in. (292 millimeters) x 8.5 in. (216 millimeters) x 4.75 in. (121 millimeters).

Weight: 13 pounds (5.9 kilograms).

Mounting: The voltage regulator may be mounted in any position providing that sufficient space is retained about the unit for satisfactory cooling, and shock and vibration do not exceed regulator specifications.

Operating Principles

General: Parts comprising the KCR 760 voltage regulator are shown on the electrical schematics.

A standard single-phase sensing KCR 760 voltage regulator with underfrequency limit or V/Hz sensing circuitry is described in the paragraphs that follow. When the regulator has either three-phase sensing or is designed for flat regulation the following difference will apply:

- When the three-phase sensing option is included the regulator will have two sensing transformers (T1 and T3) with interconnected primary windings and interconnected secondary winding.
- When the regulator is designed for flat regulation the regulator will not have the UFL or V/Hz circuitry and the voltage applied to the reference side of the first stage differential amplifier in the error detector will be the voltage across Zener diode Z1.

Voltage regulator circuits: The voltage regulator senses the generator voltage, compares a rectified sample of that voltage with a reference voltage, and supplies the field current required to maintain the predetermined ratio between the generator voltage and the reference voltage. Transformer T1 is the sensing transformer in a standard single-phase sensing KCR 760 voltage regulator while a KCR 760 voltage regulator designed for three-phase sensing includes two sensing transformers (T1 and T3). The sensing circuitry also includes a transformer (T2) and potentiometer (R4). Transformer T2, potentiometer R4, and an external current transformer provide means of attaining reactive kVA load sharing during parallel generator operation. The parallel operation components do not affect voltage regulator operation when the generator is operated singly.

On regulators equipped with underfrequency limit (UFL) or V/Hz option, this circuitry interacts with the regulator sensing and error detector in a manner that decreases voltage during underspeed operation. A solid-state flashing circuit operates each time the generator is started. The flashing circuit de-energizes when generator voltage has built up to about 70% of rated voltage output. Most of the circuits are contained on a printed circuit board. Parts that are individually mounted on the regulator case are the sensing transformer(s), parallel operation transformer T2, choke L1, nominal voltage range set adjust R2, stability adjustment R6, capacitors C32, C33, & C34, parallel voltage droop potentiometer R4, the power stage, and a fuse. External voltage adjust rheostat VAR is provided for installation on a control panel.

Sensing circuit during single generator operation: The voltage sensing transformer(s) provides a voltage proportional to the generator voltage output. This voltage is fed across the primary of T2 to a full-wave rectifier comprised of silicon diodes D3, D4, D17, D18, D23, and D24.

The rectified voltage is filtered by resistor R3, choke L1, and capacitor C1. The dc signal from the filter is applied to the error detector and the underfrequency limit.

Shorting the secondary parallel operation transformer T2, either by using the jumper bar across CT• and CT1, or turning R4 to its full counterclockwise position or setting the UNIT/PARALLEL switch to UNIT, eliminates the effect of T2 during single generator operation.

Sensing circuit during parallel generator operation in reactive voltage droop compensation mode: Generators interconnected for reactive voltage droop compensation will proportionally share inductive reactive loads during parallel operation by a decrease in generator system voltage. This method of kVAR load sharing is described in the paragraphs that follow.

The sensing transformer(s) provides a voltage proportional to the sensing voltage. A current transformer (CT) installed in line two of the generator develops a signal that is proportional in amplitude and phase to the line current. This signal develops a voltage across the slide-wire parallel voltage droop adjust potentiometer R4. The setting R4 determines how much of this voltage is applied to the primary transformer T2.

The voltage developed in the secondary of the sensing transformer(s) and the voltage developed in the secondary of T2 add vectorially. This action provides a voltage to the sensing diodes that is the vector sum of the stepped down sensing voltage and the parallel current transformer signal through T2. The sensing rectifier dc output is filtered and applied to the error detector and underfrequency limit.

When a resistive (unity power factor) load is connected to the generator, the voltage that appears across the droop potentiometer leads the sensing voltage by 90 degrees, and the vector sum of the two voltages is nearly the same as the original sensing voltage; consequently, almost no change occurs in generator output voltage.

When lagging power factor (inductive) load is connected to the generator, the voltage across the droop potentiometer becomes more in phase with the sensing voltage, and the combined vectors of the two voltages result in a larger voltage being applied to the sensing rectifiers. Since the action of the regulator is to maintain a constant voltage at the sensing rectifiers, the regulator reacts by decreasing the generator output voltage.

When a leading power factor (capacitive) load is connected to the generator, the voltage across the droop potentiometer becomes out of phase with the sensing voltage, and the combined vectors of the two voltages result in a smaller voltage being applied to the sensing rectifiers. Then the regulator reacts by increasing the generator voltage.

During parallel operation of two or more generators interconnected for reactive voltage droop, if field excitation on one of the generators becomes excessive and causes a circulating current to flow between the generators, the circulating current will appear as an inductive load to the generator with excessive excitation and a capacitive load to the other generator(s). The parallel components R4 and T2 will cause the voltage regulator of the generator with excessive field excitation to decrease the generator voltage while the voltage regulators of the other generator(s) will increase the generator voltage.

Sensing circuit during parallel generator operation in parallel cross-current compensation mode: Parallel cross-current compensation allows two or more paralleled generators to share inductive reactive loads with no droop or decrease in the generator system output voltage when the line currents are proportional and in phase. This is accomplished by the action and circuitry described previously for parallel reactive voltage droop compensation and the interconnection of the current transformer secondaries in a closed series loop. Circulating currents cause the system to react as described previously for parallel voltage droop compensation.

A unit/parallel switch connected in each generator system eliminates the series resistance of the CTs in the generator sets that are shut down from the CTs of the generator sets that are operating.

Error detector: The error detector circuitry consists of a voltage adjust circuit, a voltage divider, a two-stage differential amplifier, and an internal minor feedback filter. The voltage adjust circuit consists of an external voltage adjust rheostat VAR, a voltage range adjustment R2, and fixed resistor R1. Full travel of the external voltage adjust provides $\pm 10\%$ adjustment of the generator output voltage from nominal. The voltage range adjustment R2 establishes the maximum and/or minimum voltage adjust limit of VAR. The voltage adjust circuit and a voltage divider consisting of resistors R5 and R71 determine the input signal to the first differential amplifier.

The first differential stage is comprised of transistors Q1, Q2, & Q12, resistors R9 through R18, R21, R22, R23, R83, & R93, capacitors C3, C23, C30, & C31, ferrite beads L2 & L3, Zener diode Z1, and the circuitry within the underfrequency limit. Underfrequency limit (UFL) provides a reference voltage to the base of transistor Q2 as described in the UFL circuit description. During generator operation at rated frequency the reference signal is constant and identical to the Zener voltage. Voltage from the sensing circuit, which is proportional to the generator voltage, is applied to the base of transistor Q1. When Q1 base voltage is different from the reference voltage applied to the base of Q2, there will be a difference in Q1 collector current with respect to Q2 collector current.

The current from the collector of transistor Q1 is divided by resistors R9 and R16 and injected into the base of the second stage differential amplifier transistor Q3. Similarly, the current from the collector of

transistor Q2 is divided by resistors R14 and R15 and injected into the second stage differential amplifier transistor Q4. Resistors R10 and C3 help to prevent oscillations at high frequencies. The second stage differential amplifier amplifies the output of the first stage differential amplifier. Components included in the second stage differential amplifier are transistors Q3 and Q4, and resistors R24 through R27. The collector voltage of transistor Q3 controls the phase control circuit. The minor feedback filter consists of resistor R8 and capacitor C2. The filter removes any remaining ac from the dc signal.

Phase control circuit: One of T1's secondary windings, diodes D1, D2, D21 & D22, resistors R87 & R88, capacitors C20, C21, & C22, supply power to the first and second differential stage and the underfrequency limit stage. The phase control circuit consists of diodes D5 and D6, resistors R28 through R32, & R80, capacitors C20, C21, & C22, Zener diode Z2, and programmable unijunction transistor (PUT) Q5.

The phase control circuit is a "ramp-and-pedestal" control that regulates the phase angle of the power controller circuit SCRs by controlling the "turn on" signal it supplies to the gate of the SCRs. An exponential ramp voltage that starts from a voltage pedestal provides the "turn on" gating signal. Because the ramp voltage starts from the voltage pedestal, a small change in the amplitude of the pedestal voltage results in a large change in SCR phase angle as shown in Figure 2.

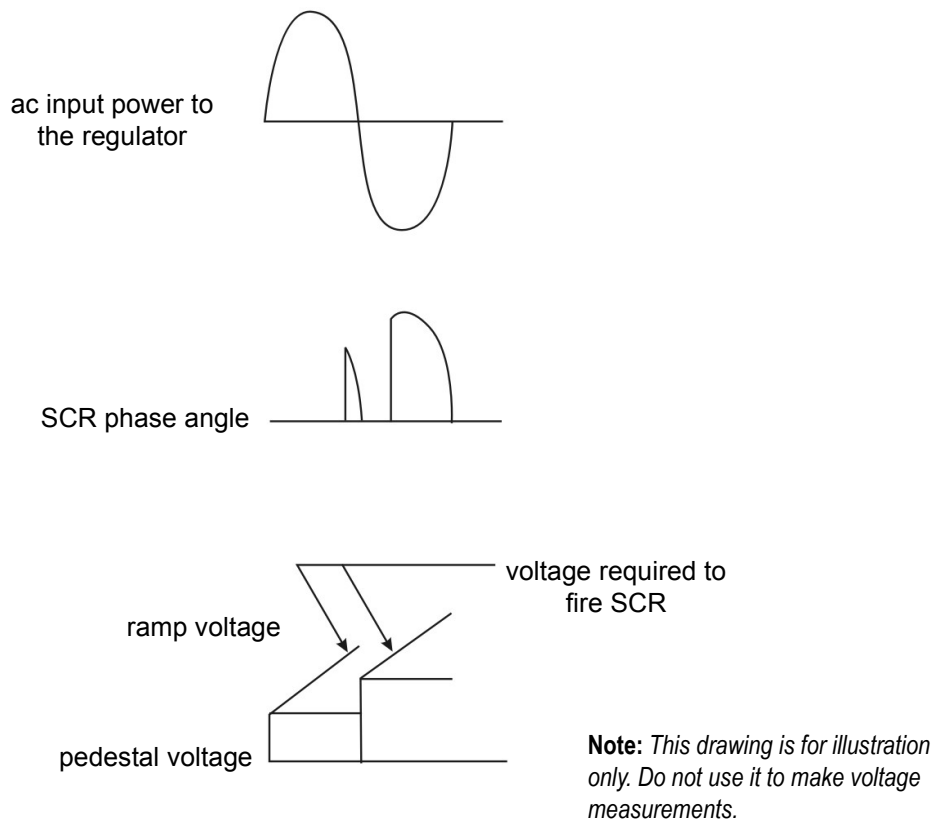

Figure 2: Effect of timed gating signal on SCR phase angle

The amplitude of the pedestal voltage is determined by the collector current of second stage differential amplifier transistor Q3. Zener diode Z2 serves as a voltage clamp and resistors R31 and R32 are a voltage divider, which determines the threshold of the programmable unijunction transistor Q5. The output of PUT Q5 is applied to the gate of the power controller SCRs through resistors R43 & R44 and diodes D15 & D16 and an amplifying stage that is comprised of transistor Q11, diode D10, resistors R46 & R81, and capacitor C24.

Power stage (power controller): The power stage supplies the generator exciter field current. The power stage consists of an SCR/diode bridge rectifier. The power stage input is either single phase 120 Vac or single phase 240 Vac depending on regulator design. The output of the power stage is regulated by the “turn on” gating signal that its SCRs receive from the phase control circuit. The circuit includes a free wheeling diode for field discharge of the inductive exciter field load and a fuse (F1) in its input power line.

Field flashing circuit: The field flashing circuit includes SCR1, field effect transistor (FET) Q6, transistors Q7 through Q10, resistors R34 through R42, R82, and R85, Diodes D7, D11, & D29, and capacitors C25 & C27. Transistors Q8 and Q9, diode D7, and resistors R36, R37, R38, R40, & R41 comprise a Schmidt trigger circuit. The Schmidt trigger turns on when an increasing voltage is present with magnitude approximately 70% of the nominal 24 Vdc output of the sensing rectifiers, and turns off when a decreasing voltage is present with magnitude of approximately 30% of the nominal output of the sensing rectifier.

When the Schmidt trigger is off, FET Q6 is on. This action turns on transistors Q10 and Q7, which supply current to fire slave SCR1 located on the circuit board. Slave SCR1 fires the silicon controlled rectifiers SCR1 and SCR2 in the regulator power controller circuit which, when on, supply current to the exciter field. When the Schmidt trigger turns on, FET Q6 turns off. This action turns off transistors Q10 and Q7, which removes the gating signal to slave SCR1 and in turn the gating signal of the flashing circuit from the power controller SCRs.

Resistor R70 and capacitor C19 provide assistance in the firing of the power stage SCRs. Capacitor C8 and resistor R45 assist in limiting conducted EMI. Diodes D8, D9 and those in the power stage supply power to the flashing and phase control circuits.

Stability control: The stability circuit is a rate feedback RC network. It consists of capacitors C4 and C5, resistors R7, R19, and R20, and stability adjust potentiometer R6. This RC network injects a stabilizing signal from the regulator output which helps to prevent generator voltage oscillation.

Underfrequency limit (UFL): The UFL provides a reference voltage to the error detector which is constant when the generator output frequency

is higher than a predetermined limiting frequency. When the generator is operating slower than the predetermined UFL operational threshold, the UFL will provide the error detector with a reference voltage that is proportionally lower.

The reference voltage to the UFL is supplied by Zener diode Z1. The UFL operational threshold for standard 50 Hz, 60 Hz, and 400 Hz KCR 760 regulators are given above. The operation of the various components comprising the UFL assembly is described in the paragraphs that follow.

The voltage from the sensing transformer is rectified by diodes D19 and D21, and the rectified signal is applied to a Schmidt trigger consisting of operational amplifier IC2A, resistors R47 through R51, and capacitor C29. A 24 Vdc peak-to-peak square wave is generated at the output of IC2A at double the frequency of the sensing voltage.

The 24 Vdc square wave from the Schmidt trigger is fed to the first stage of a two-stage monostable multivibrator IC1 and associated parts, where it is decreased to a 5 Vdc peak-to-peak square wave at double the frequency of the sensing voltage. The 5 Vdc square wave is applied to the second stage of the monostable multivibrator. The monostable multivibrator output pulse is uniform in amplitude and duration for each input pulse. Thus, the average voltage level of the collective pulses at the output of the monostable multivibrator is directly proportional to the frequency of the pulses. The monostable multivibrator output is fed into a four-pole Butterworth low pass filter comprised of operational amplifier IC2B and IC2C, resistors R60 through R66, and capacitors C13 through C18. This filtering circuit does the actual averaging of the collective pulses from the monostable multivibrator. Amplifier gain is set at level where its output equals the Zener reference at rated 60 Hz or 400 Hz operation by resistors R65, R66, and capacitor C16. When operated at rated frequency of 50 Hz, the circuit is set for 50 Hz operation by removing jumper J1. This action adds R57 to the circuit.

Diode D12 and integrated circuit IC2D form a voltage clamping circuit. If the voltage from the Butterworth filter is equal to that of the Zener reference, the UFL output to the error detector will be the same as the Zener reference and the UFL will have no effect on regulator operation. However, when the voltage from the filter decreases as occurs during underspeed operation of the generator, the reference voltage applied to the error detector is less than the Zener reference. This action will cause the error detector differential signal to proportionally increase in a manner that results in a proportionally later turn-on signal to the regulator output SCRs. The regulator then decreases excitation and a lowering of generator output voltage occurs.

Resistors R54 & R56, potentiometer R55, and capacitor C12 determine the underfrequency limit operational threshold. Zener diode Z3 and capacitors C9 and C10 protect the integrated circuits from damage should excessive voltage spikes occur.

Note: *The underfrequency limit circuitry is not included when the regulator includes the flat regulation option. Where regulator is supplied with the V/Hz sensing option, operation and construction of the V/Hz circuitry is similar to the underfrequency limit.*

Installation

Mounting: The voltage regulator can be mounted in any position without affecting its operating characteristics. The voltage regulator is convection cooled. Retain sufficient space around the regulator for heat dissipation and for making electrical connections and controls adjustments. Mount the voltage regulator in any location where shock and vibration are not excessive and the ambient temperature does not exceed its ambient operational limits.

Warning: *De-energize the generator set starting circuit before making repairs, connecting test instruments or removing or making connections to or within the voltage regulator. Dangerous voltages are present at the voltage regulator terminal boards and within the voltage regulator when the generator set is running. These include the sensing voltage, power to the voltage regulator, and the voltage regulator output. Accidental contact with live conductors could result in serious electrical shock or electrocution.*

Caution: *Do not use a megger or high potential test equipment when testing the voltage regulator. Disconnect interconnecting conductors between the generator and voltage regulator when testing the generator or exciter with a megger or high potential test equipment. The high voltage developed by megger or high potential test equipment will destroy the solid state components within the voltage regulator.*

Caution: *Never open the regulator sensing circuit while power is applied to the regulator input power terminals. Loss of sensing voltage will result in maximum regulator output.*

Interconnection: Connect the regulator to the generator system as instructed in this section and as shown in the connection diagram provided with the generator set. See Figure 3 for an overall outline drawing that shows the location of regulator mounting provision and parts of the voltage regulator. See Figures 4 to 11 for a typical interconnection diagrams and electrical schematics of the voltage regulator. Use 14 gauge or larger wire for connections to the voltage regulator.

Single-phase 100 to 600 Vac sensing (terminals E1 and E3): The standard KCR 760 voltage regulator designed for single phase sensing has an internal sensing transformer (T1) as shown in Figure 4. This transformer is provided with taps on the primary winding for sensing voltages of 100 to 139, 200 to 228, 216 to 265, 375 to 458, 432 to 528, and 540 to 600 Vac. The transformer primary winding taps are identified with the corresponding nominal voltages, which are 120, 208, 240, 416, 480, and 600. Vac. To obtain proper operation the internal wire from voltage regulator terminal E3 must be connected onto the correct primary tap on transformer T1. Electrical wires within the regulator connect to the sensing transformer secondary winding as shown in Figure 4.

Three-phase 100 to 600 Vac sensing (terminals E1, E2, and E3): When the regulator is designed for three-phase sensing, it includes two sensing transformers (T1 and T3) as shown in Figure 5.

Except when otherwise specified in the purchase order, the regulator sensing transformers will both include multi-tap primary winding for use with the sensing voltages described in the single phase 100 to 600 Vac sensing procedure.

To properly operate, connect the internal wire from voltage regulator terminal E3 to the correct primary winding tap on transformer T1, and connect the internal wire from voltage regulator terminal E2 to the corresponding primary winding tap on transformer T3. Connect electrical wires within the regulator to the sensing transformer's secondary winding as shown in Figure 5.

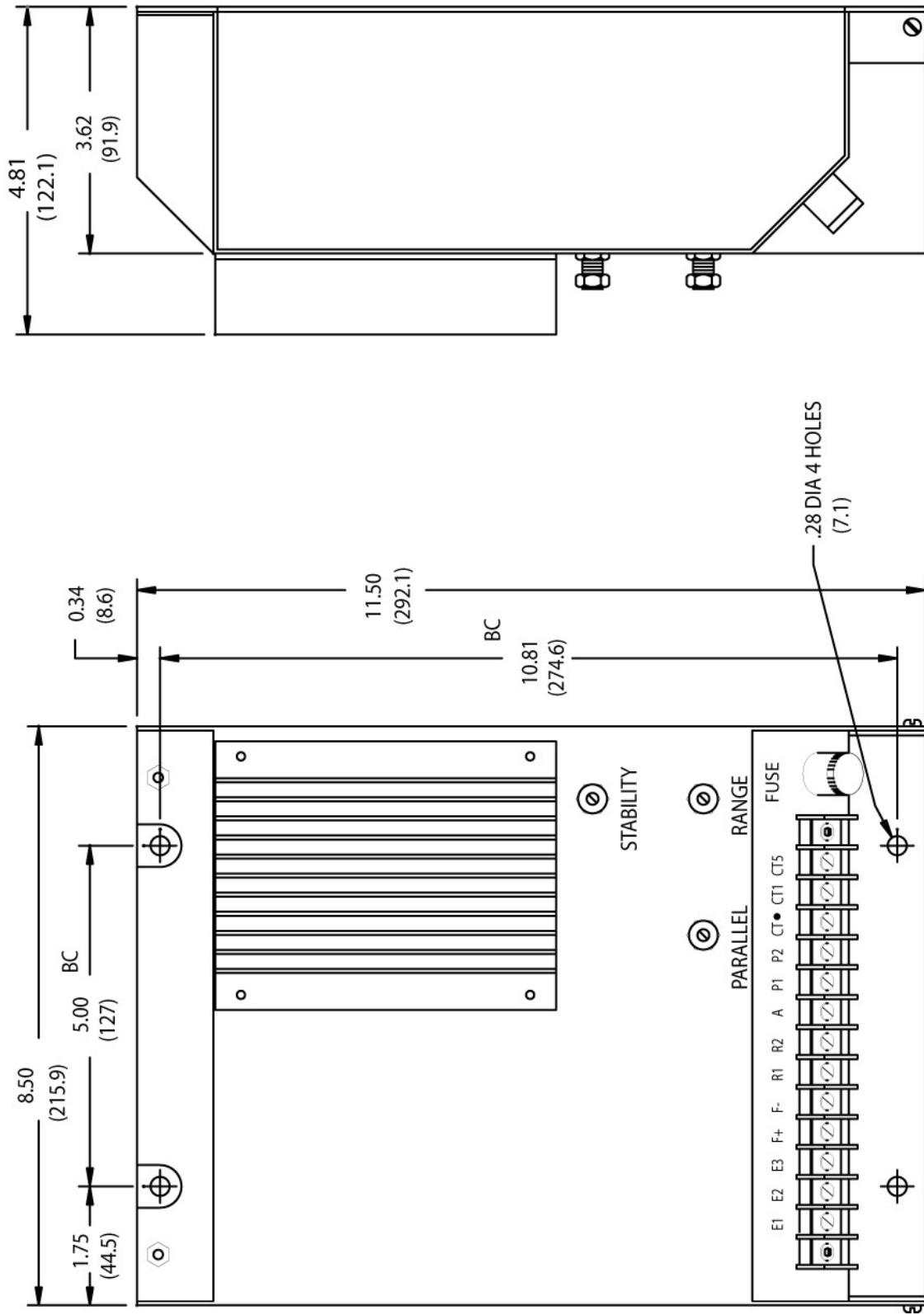

Figure 3: KCR 760 outline drawing

Notes:

Sensing: Using sensing terminals E1 and E3, the internal wire form E3 must connect to the tap on T1 that matches the generator voltage.

Parallel operation: An external current transformer is required for parallel operation. Where the current transformer has a 1 A secondary, connect to terminals CT• and CT1. Where the current transformer has a 5 A secondary, connect to terminals CT• and CT5. For single generator operation, remove the droop signal by adjusting R4 to 0 resistance measured across terminals CT• and CT1.

Fuse F1: Has normal blow: 15 A maximum for voltage regulator protection.

Input power: For 120 Vac input with 65 Vdc output: install circuit board jumper J3. For 240 Vac input with 125 Vdc output, remove the circuit board jumper J3.

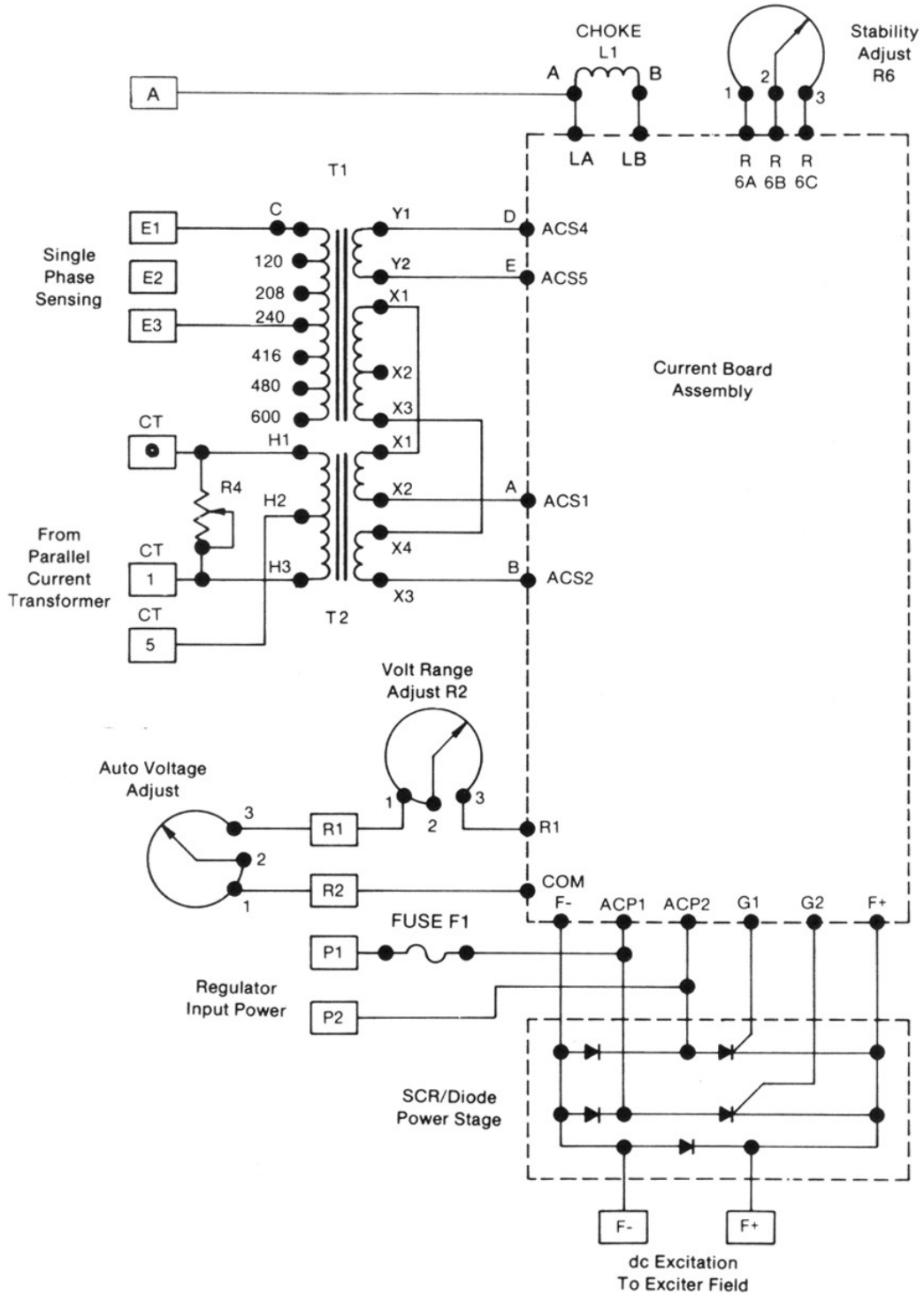
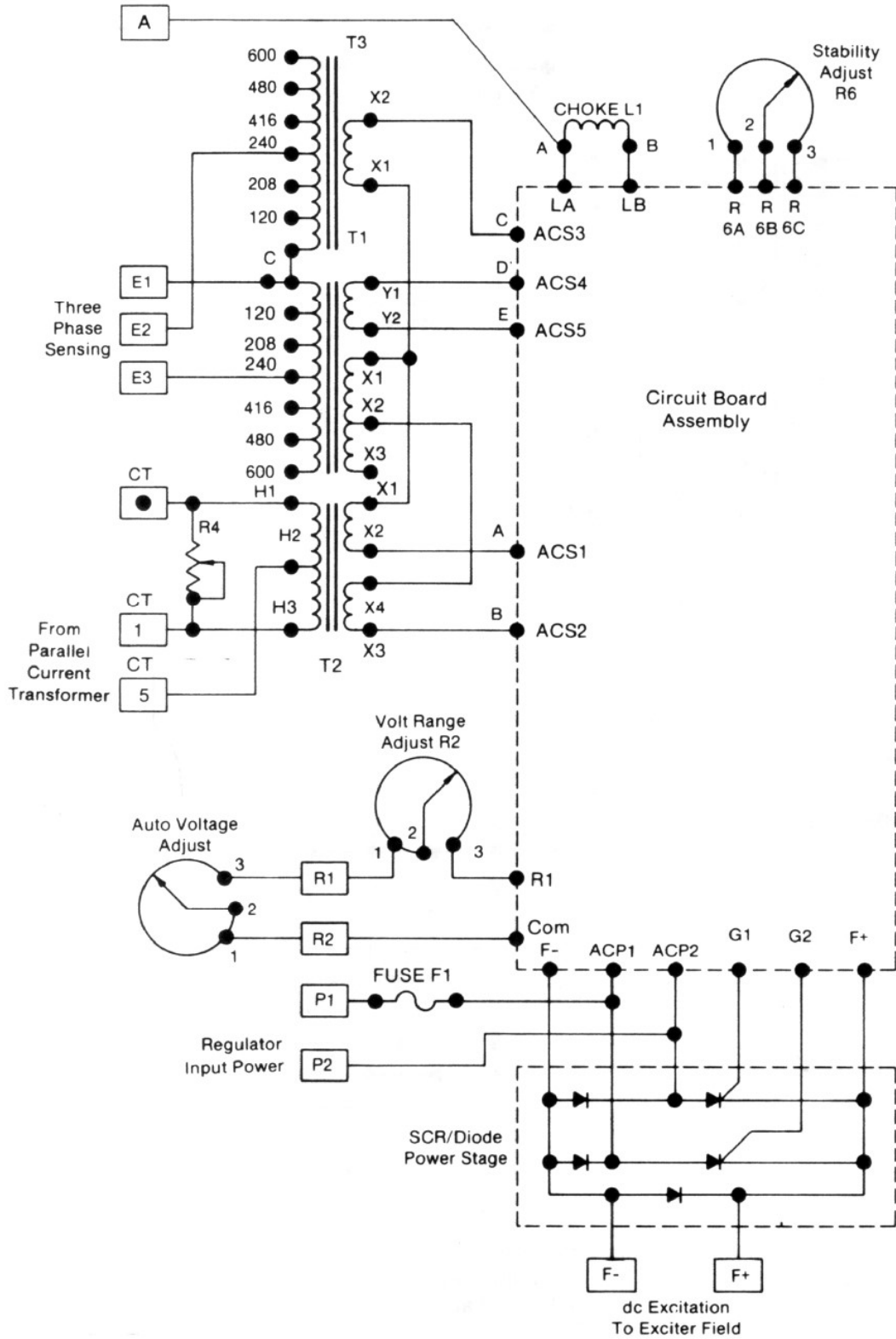

Figure 4: KCR 760 single-phase sensing schematic



Notes:

Sensing: Uses terminals E1, E2, E3 and sensing transformers T1 and T3. The wire from E2 must connect to the tap on T3 that matches the generator voltage. The wire from E3 must connect to the tap on T1 that matches the generator voltage.

Parallel operation: An external current transformer is required for parallel operation. Where the current transformer has a 1 A secondary, connect to terminals CT• and CT1. Where the current transformer has a 5 A secondary, connect to terminals CT• and CT5. For single generator operation, remove the droop signal by adjusting R4 to 0 resistance measured across terminals CT• and CT1.

Fuse F1: Has normal blow: 15 A maximum for voltage regulator protection.

Input power: For 120 Vac input with 65 Vdc output: install circuit board jumper J3. For 240 Vac input with 125 Vdc output, remove the circuit board jumper J3.

Figure 5: KCR 760 three-phase sensing

Note: Jumper wire J3 on the regulator circuit board is installed when regulator input power is 120 Vac \pm 10% and removed when input power is 240 Vac \pm 10%.

Input power (terminal P1 and P2): Before making electrical connections, refer to the wiring diagram provided with the generator. Connect input power as follows.

- When the regulator is designed for 120 Vac \pm 10% input power and 65 Vdc maximum continuous output, connect single-phase 120 Vac power to terminals P1 and P2. Refer above for recommended use of load isolation and voltage matching transformers.
- When the regulator is designed for 240 V ac \pm 10% input power and 125 Vdc maximum continuous output, connect single-phase 240 Vac power to terminals P1 and P2. Refer above for recommended use of load isolation and voltage matching transformers.
- When the regulating system is supplied with electromagnetic interference filters, connect as shown on the wiring diagram provided with the generator set.

Output power (terminals F+ and F-): Be sure regulator output matches the generator exciter rating. The KCR 760 voltage regulator designed for 120 Vac input is designed for 65 Vdc maximum continuous output. The KCR 760 voltage regulator designed for 240 Vac input is designed for 125 Vdc maximum continuous output.

Maintain correct polarity between the regulator output and exciter field.

Make sure field resistance for the 65 Vdc regulator is not less than 6.5 Ω and field resistance for the 125 Vdc regulator is not less than 12.5 Ω .

Make sure the field circuit is not grounded and/or opened or shorted during operation of the generator set.

Because the regulator output leads are not connected to any part of the system except the exciter field, they are not filtered. To minimize conducted EMI the keep the leads as short as possible and shielded. Effective shielding can be attained by routing both leads through 0.5 inch conduit. In general, do not leave unshielded more than 1 to 2 feet of field leads. If the voltage regulator is installed within the generator outlet box, it is possible to achieve satisfactory results with short unshielded leads.

Grounding: A good electrical power ground is not necessarily a good electromagnetic interference ground. Make the ground leads as short as possible, preferably of copper strap with a width of 1/5 the length. Grounding the chassis to earth ground makes all grounds common.

External voltage adjust rheostat (terminals R1 and R2): Terminals R1 and R2 are provided for connection of the voltage adjust rheostat. The rheostat provides adjustment of the regulated generator voltage \pm 10% of

nominal. It is provided as a separate item for panel mounting. Connecting wires from the rheostat attach to terminals R1 and R2. A jumper wire must be connected between rheostat terminal 2 and rheostat terminal 1 as shown in Figure 6.

Connection to reactive voltage droop terminals CT•, CT1, and CT5

Parallel operation: When generators will be operating in parallel, install the current transformer in Phase B from each generator and connect as follows:

- Current transformer (1 A secondary): Connect secondary leads to CT• common and CT1. Be sure to maintain correct polarity. Make certain the jumper, when supplied, is removed from across CT• and CT1.
- Current Transformer (5 A secondary): Connect secondary leads to CT• common and CT5. Be sure to maintain correct polarity. Make certain the jumper, when supplied, is removed from across CT• and CT1.

Reactive voltage droop or cross-current compensation: The regulating system may be connected for parallel operation in either the reactive voltage droop or cross-current compensation mode. Connect according to either reactive voltage droop or cross-current compensation.

- Reactive voltage droop: Connect the current transformer to the respective regulator (see Figure 7).
- Cross-current compensation: For cross-current, connect each CT to its respective regulator. Then connect the finish of the first CT to the start of the third CT, etc. Continue until all CTs are connected in series and connect the finish of the last CT to the start of the first CT (see Figure 8).
- On parallel cross-current compensation applications consisting of two or more generators, use a unit/parallel switch if all the generators are not always on the bus. If the switch is not used, a voltage droop will be introduced into the system, which will cause the voltage of the incoming generator to fluctuate prior to paralleling. This is due to the unloaded generator parallel CT not supplying its compensating signal, but allowing a voltage drop to occur across it. Ideally, the switch is an auxiliary on the generator output circuit breaker that opens when the breaker is closed.

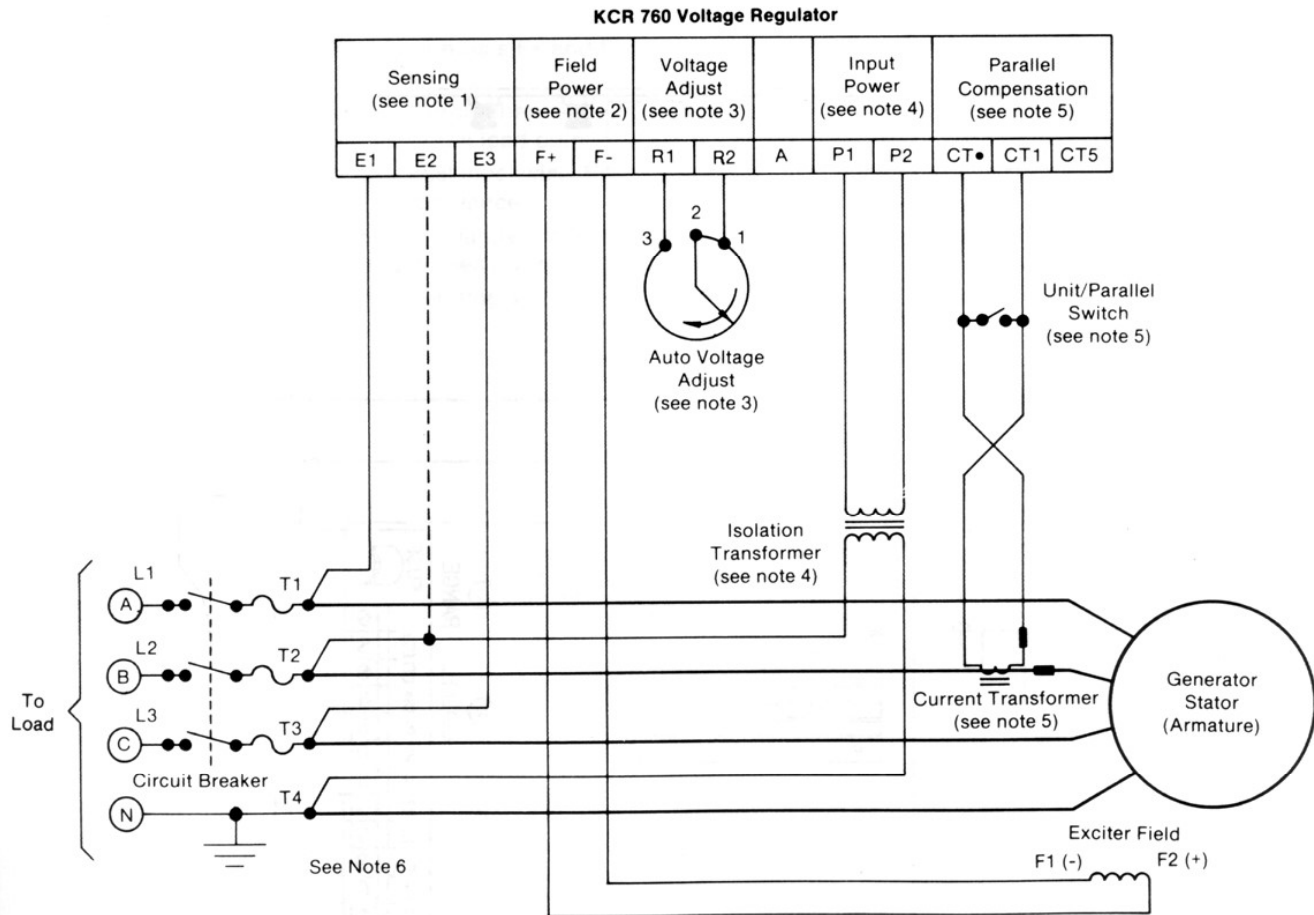

Notes:

- 1) For single-phase sensing, terminals are E1 and E3. See Figures 2 and 3.
- 2) The field must not be opened, shorted or grounded while the generator is operating.
- 3) The external voltage adjust must have a jumper across its terminals 1 and 2.
- 4) Input power standard KCR 760 voltage is 120 Vac; optional 240 Vac. Maximum continuous output is 65 Vdc for a 120 Vac input and 125 Vdc for a 240 Vac input. See Figures 4 and 5.
- 5) A current transformer is required for generators operating in parallel. The connection is shown on this drawing: 1 A current transformer and reactive voltage droop compensation. See Figures 2 and 3.
- 6) Ground the neutral in accordance with applicable electrical codes.

Figure 6: KCR-760 interconnection

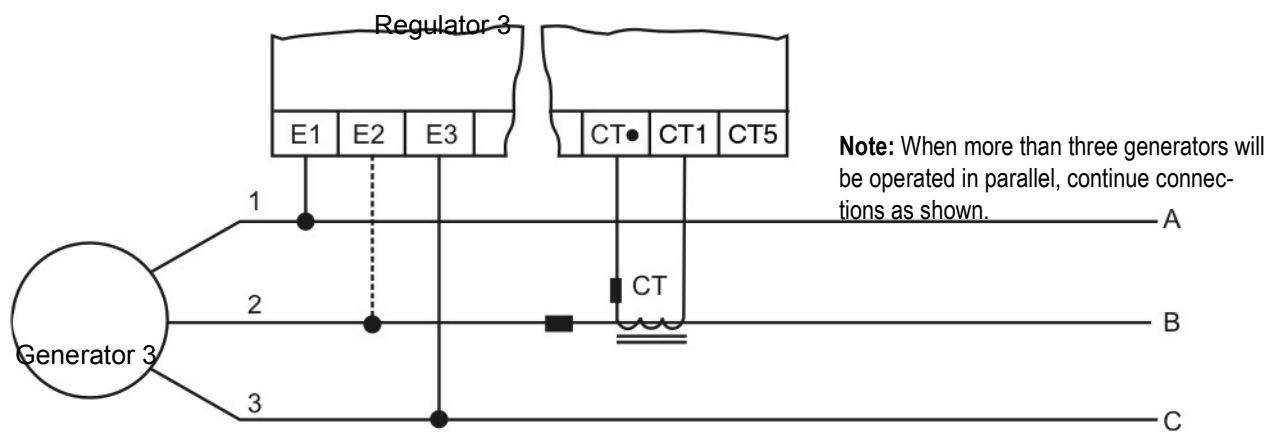
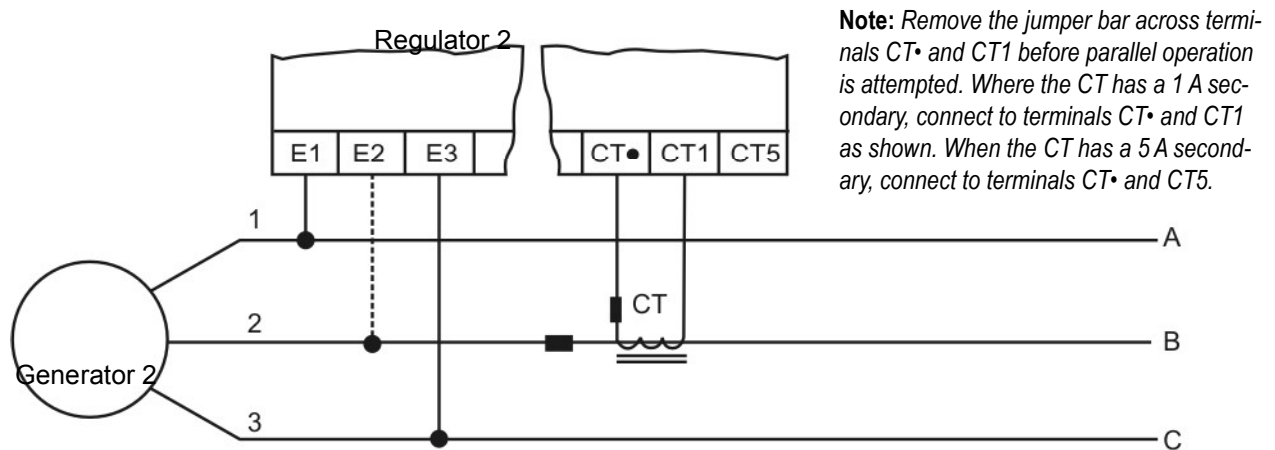
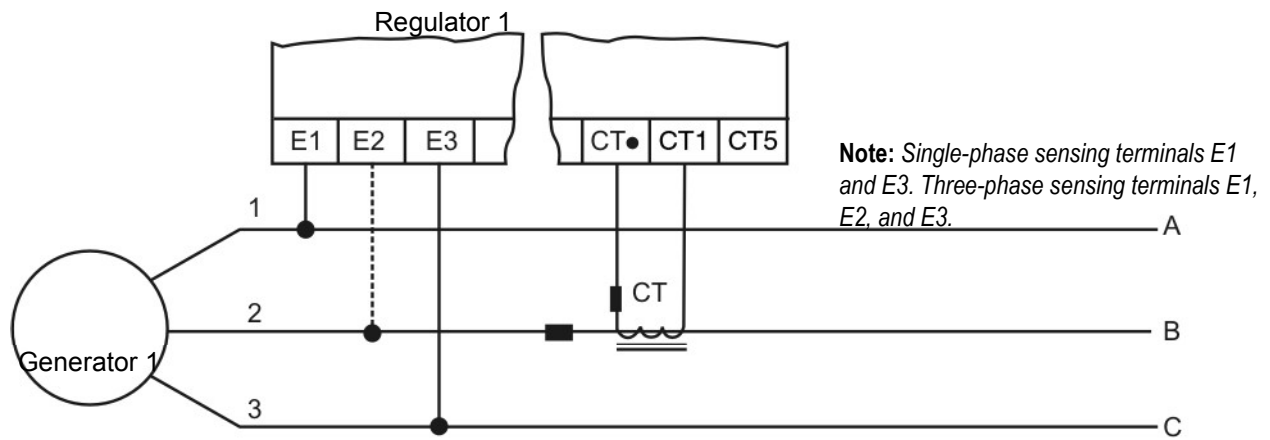

Figure 7: Parallel operation, reactive voltage droop mode

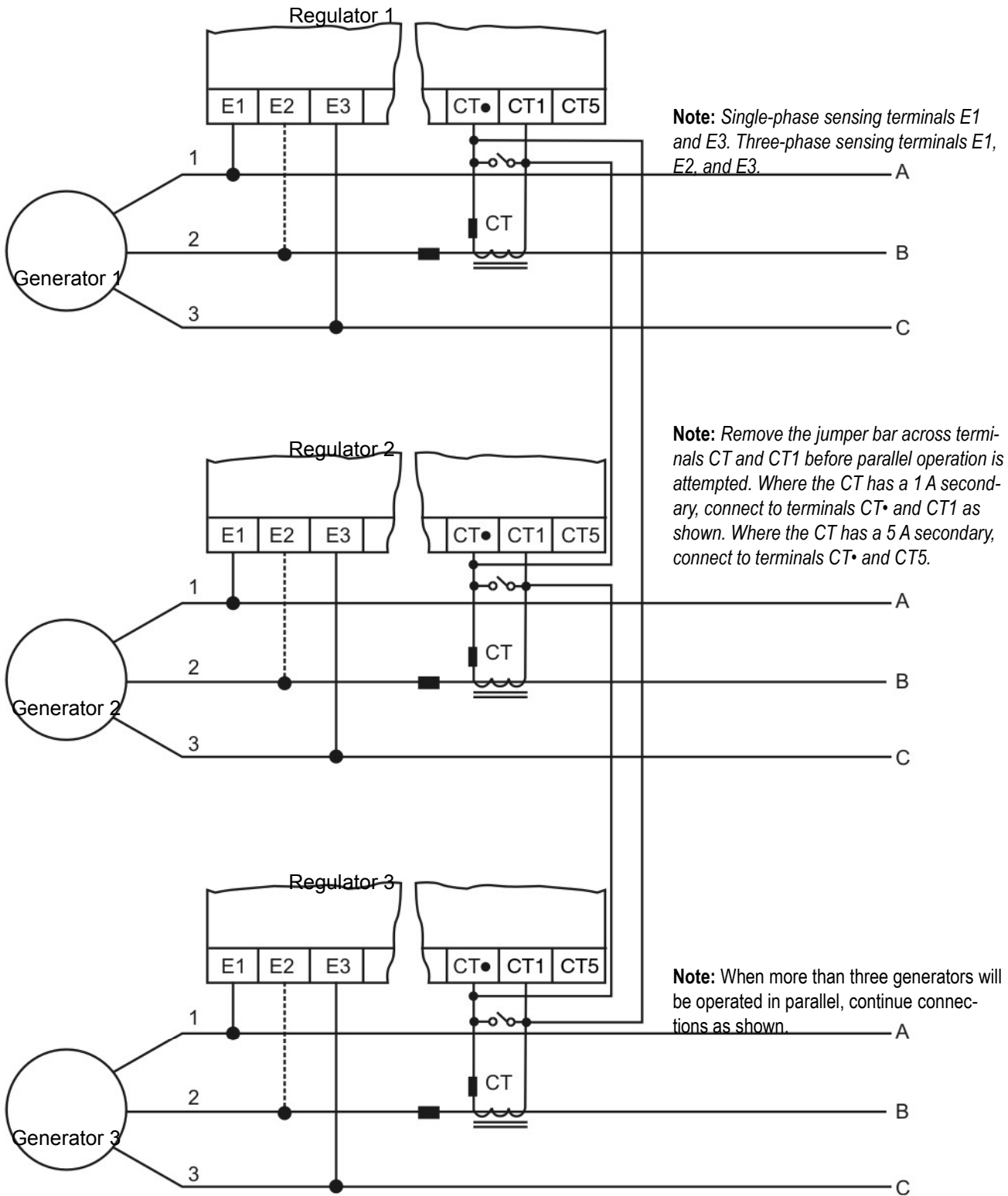

Figure 8: Parallel operation, cross-current compensation mode

Generator operating singly: When generators are not operating parallel and reactive voltage droop is not required, use one of the following methods to eliminate the effect of the parallel operation transformer within the voltage regulator.

- Install a unit/parallel switch across the current transformer secondary, and close switch during single generator operation.
- Set the voltage droop resistor R4 to its minimum droop position.
- Where the generator will be operating singly, install a jumper across terminals CT• and CT1.

UFL circuit 50/60 and 400 Hz selector J1: The underfrequency limit components or V/Hz components are located on the voltage regulator circuit board (see Figure 9). Parts comprising the UFL or V/Hz components are shown in Figure 11. A jumper wire J1 eliminates the effect of resistor R57. Removing the jumper J1 places R57 in the circuit.

60 or 400 Hz operation: Make certain the jumper wire is installed across area marked J1. Wire is mounted on component side of circuit board and ends of jumper wire are soldered on foil side of the circuit board.

50 Hz operation: Make certain the jumper wire is removed from across area marked J1. Remove J1 by cutting each end of the jumper wire.

Voltage regulator fuse: The voltage regulator contains a 15 A normal blow fuse in the voltage regulator input power circuit (see Fig. 1, 2 and 3). In applications where voltage regulator power requirements are reduced, as when used with small generators where excitation is less than given, a smaller fuse may be used. Never install a fuse larger than 15 A and never install a delay-type fuse.

Accessory items: Accessory items provided with the generator system must be connected as shown on the wiring diagram provided with the generator set and the accessory item drawing or instruction. Observe the precautions and general procedures that follow when connecting accessory items.

Voltage shutdown (engine idle switch): The system can be equipped with a switch to allow removal of excitation in an emergency or when the prime mover must be operated at reduced speeds. This switch must be placed in the input power line to the regulator (terminal P1 or P2).

Field circuit breaker: The field circuit breaker must be of the type that has separate terminals for the thermal element and the contacts. The circuit breaker thermal element receives heat from either the field current or generator line current. Where it is heated by field current, the thermal element connects between the voltage regulator output and the

Warning: A fire hazard can exist if the voltage regulator fuse is larger than 15 A or if a delay-type fuse is used.

Note: On generator systems that include the auto/manual voltage control option, the OFF position on the AUTO/OFF/MANUAL selector switch provides voltage shutdown. On generator systems that include a field circuit breaker, manually tripping the circuit breaker OFF provides voltage shutdown.

Caution: Never install the voltage shutdown switch in the exciter field circuit as the voltage regulator dc output (terminals F+ and F-) must not be opened during operation. To do so would produce inductive arcing that could destroy the exciter or voltage regulator output power bridge.

Caution: Never open the dc output (terminals F+ and F-) during operation. To do so would produce inductive arcing that could destroy the exciter or voltage regulator. Therefore, never place circuit breaker contacts in the exciter field circuit.

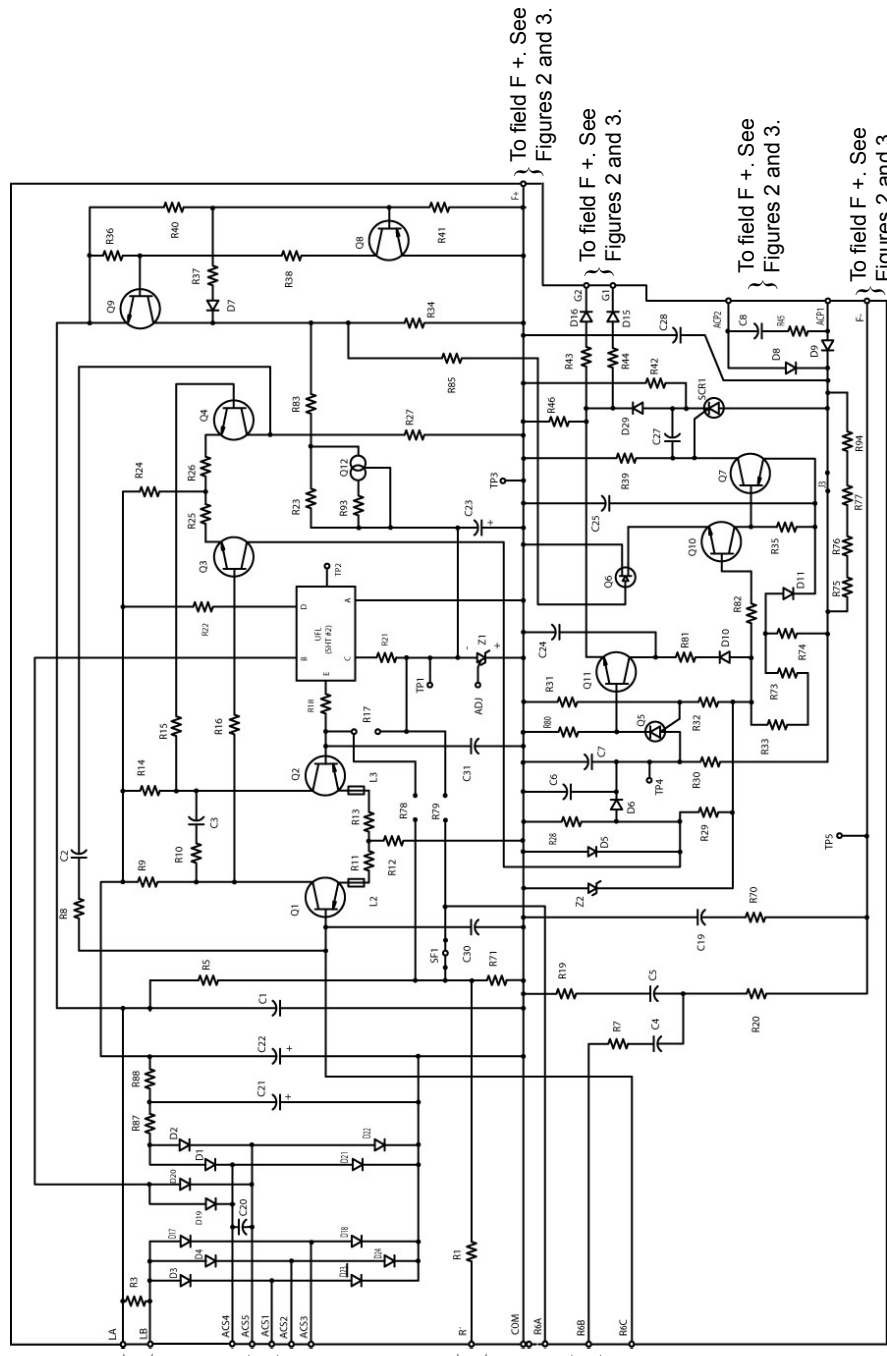

Note: Install jumper J3 when input is 120 Vac, and remove it when input is 240 Vac.

Note: For a schematic of UFL circuitry, see Figure 11.

From sensing transformers. See Figures 2 and 3.

To voltage range adjust and voltage adjust. See Figures 2 and 3.

From stability control. See Figures 2 and 3.

From sensing choke. See Figures 2 and 3.

To field F+. See Figures 2 and 3.

To field F+. See Figures 2 and 3.

To field F+. See Figures 2 and 3.

To field F+. See Figures 2 and 3.

Figure 9: KCR 760 (with UFL or volts-per Hz) circuit board schematic

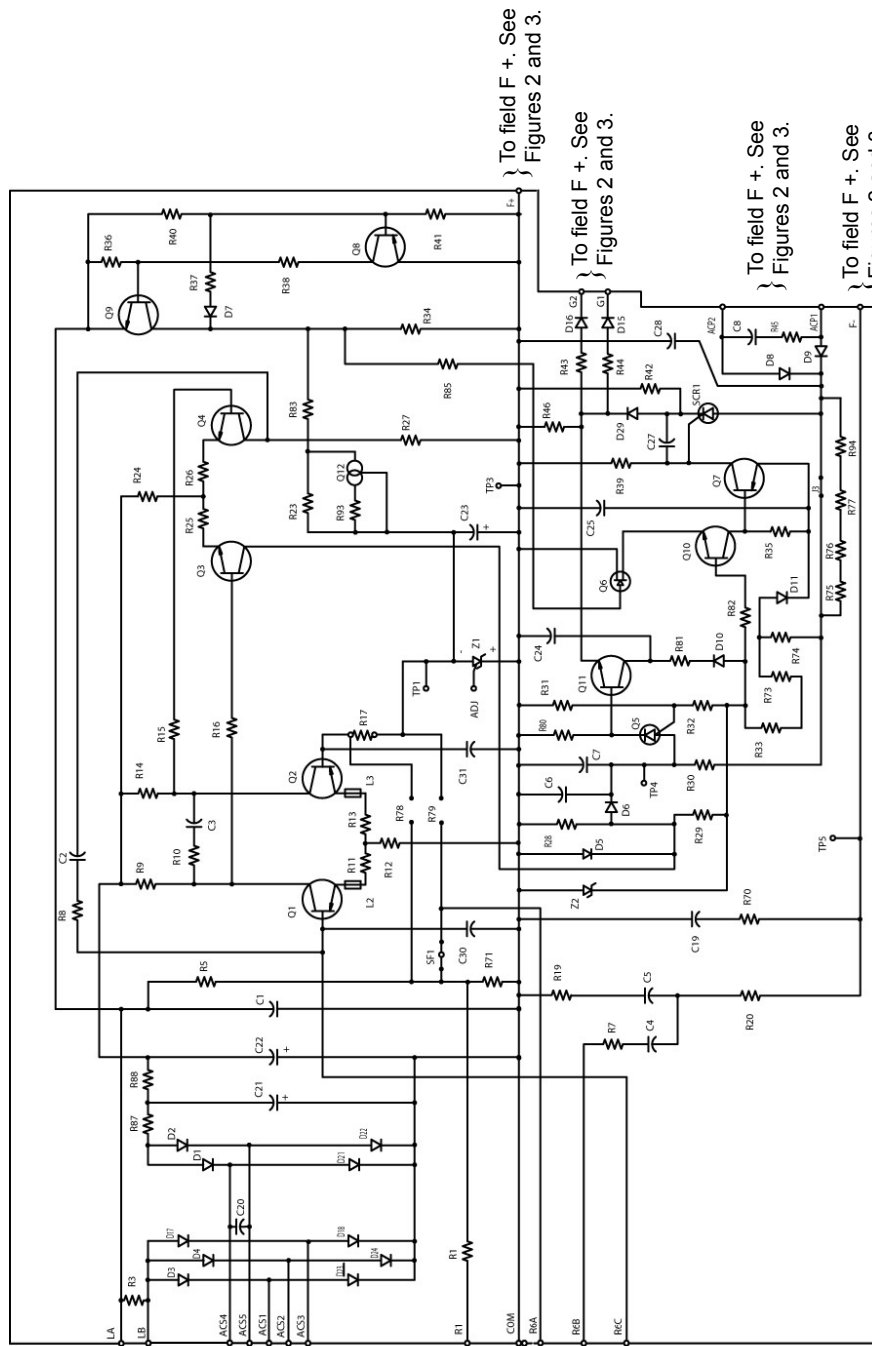

From sensing transformers. See Figures 2 and 3.

To voltage range adjust and voltage adjust. See Figures 2 and 3.

From stability control. See Figures 2 and 3.

From sensing choke. See Figures 2 and 3.

Note: With jumper J3, install when input is 120 Vac, and remove when input is 240 Vac.

Figure 10: KCR 760 (with flat regulation option) circuit board schematic

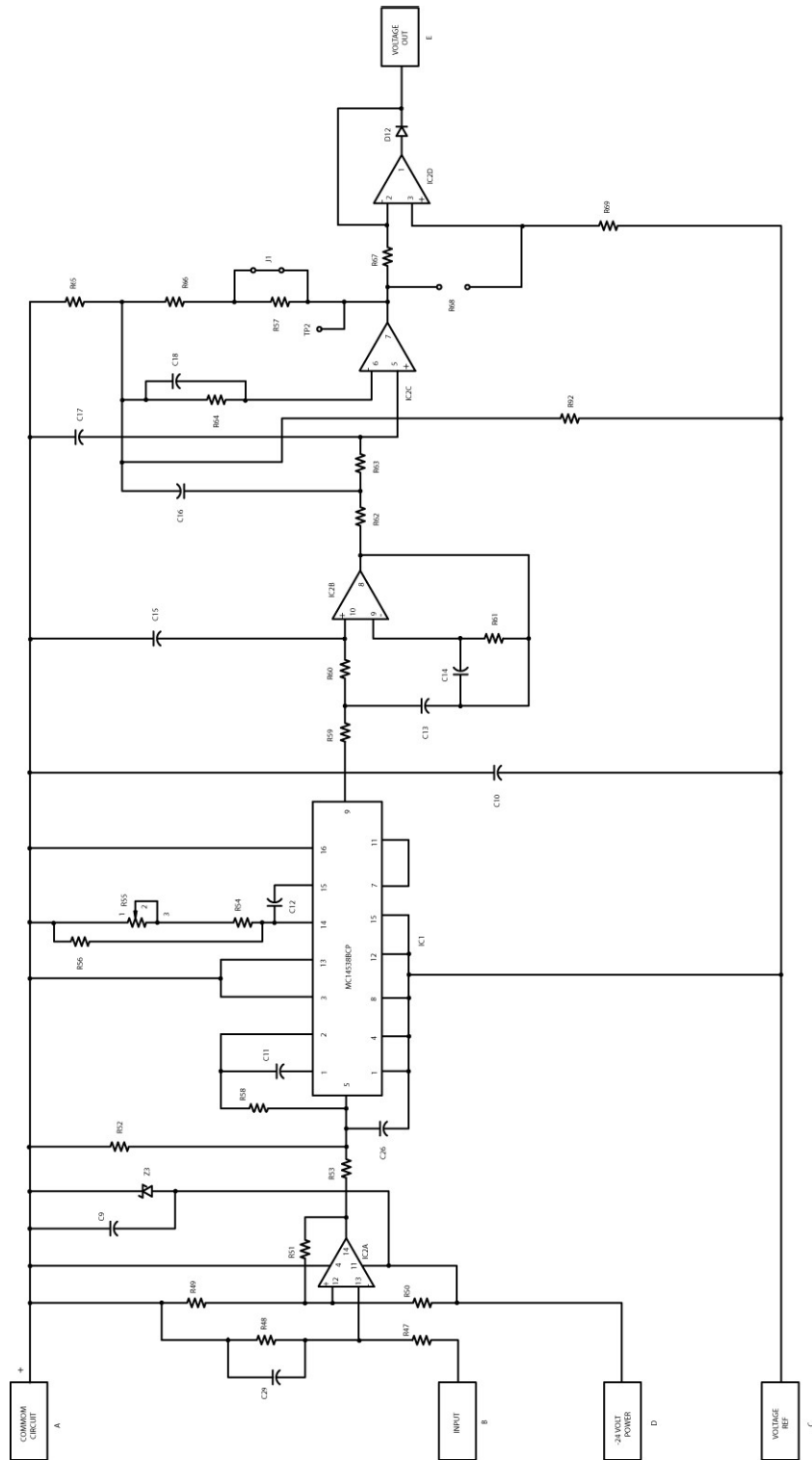

Figure 11: UFL electrical schematic

exciter field. Where it is heated by generator line current, the thermal element connects to a current transformer located in one of the generator load lines.

Auto/manual voltage control: The auto/manual voltage control option includes the components described below. Connect the auto/manual voltage control module as shown on the wiring diagram provided with the generator.

- Three-position selector switch: When this switch is set to the AUTO, power is fed across the switch contacts to the regulator input power terminal P1 and P2. When the switch is set to MAN, power is fed across the switch contacts to the manual voltage control circuit rectifiers. OFF position opens input power to both the voltage regulator and the manual voltage control rectifiers.
- Manual voltage control circuit: The manual voltage control circuit consists of a full wave rectifier assembly and a manual voltage control variac. The manual voltage control variac controls generator output whenever the generator set is operated in the manual voltage control mode of operation.

Operation

Caution: Before initial operation, verify that the regulator is connected for the application. See wiring diagram provided with the generator set and review the procedures given above.

Adjustments: The adjustments pertaining to the voltage regulator and system operation are described in the paragraphs that follow and, except where noted, adjustment is made during initial operation and normally does not have to be repeated during the life of the voltage regulator.

Generator voltage adjust rheostat (VAR): This adjustment is provided to control the generator voltage. When set to its maximum counterclockwise position, minimum generator voltage is obtained. Maximum generator voltage is obtained when the rheostat is set to its maximum clockwise position.

Nominal voltage range set adjust (R2): This adjustment is provided to extend the limits of the generator voltage adjust rheostat (VAR). Normally R2 is set to provide the generator voltage adjust rheostat with an adjustment range of $\pm 10\%$ of rated voltage. R2 is located on the regulator. Loosen the 1/2 inch locknut before attempting to adjust R2 (with a small screwdriver). Retighten the locknut after adjustment is complete.

Stability adjustment (R6): Stability control R6 provides for stable regulating operation by controlling the amount of feedback that is applied to the error detector stage. Turning the control counterclockwise decreases the amount of the stability feedback, making the regulator respond faster.

This control is located on top of the cover, mounted below the heat sink and above the RANGE adjust. Loosen the 9/16 inch hex-head locknut that keeps the control shaft from turning due to vibration before attempting to adjust R6 (with a screwdriver). Retighten the locknut after adjustment is complete.

Operate the generator at rated frequency, no load, the point at which the stability adjustment is most critical. Adjust STABILITY by first rotating the control fully clockwise with screwdriver. One end of the screwdriver slot will point to 2 o'clock; this end is the pointer. Set the STABILITY by rotating pointer counterclockwise to 10 o'clock. This setting normally ensures good stability, but may not provide optimum response time for the generator.

If the generator voltage oscillates (hunts), turn the control clockwise past the point where oscillation stops. If faster response is required, rotate the control counterclockwise until the voltage becomes unstable, and then rotate clockwise until the voltage is stable. Optimum adjustment is attained when generator voltage is stable and response is satisfactory at no-load and also during operation under any load up to the full load rating of the generator.

Parallel voltage droop potentiometer (R4): This adjustment is provided to control the voltage droop signal of generators operating parallel. It is located on the regulator chassis. Maximum voltage droop is attained when the potentiometer is set to its maximum clockwise position. Adjust each generator that will be operated parallel for identical voltage droop as described in the parallel operation procedure that follows. Make the adjustment by loosening the locknut with a 1/2 inch wrench, adjusting the droop with a screwdriver and then tightening the locknut after the adjustment has been made.

Underfrequency Adjustment (R55): This adjustment is included in voltage regulators provided with the underfrequency limit option. R55 is adjusted at the factory as listed above or as requested in the generator purchase order.

- Adjusting the underfrequency limit when the generator frequency can be set to the desired breakpoint:
 1. Connect a voltmeter between the circuit board terminals TP1 and TP2.
 2. Run generator at the desired underfrequency limit set point (for example 58 Hz).
 3. Adjust R55 for 0 volts as indicated on the meter.

- Adjusting the underfrequency limit when generator frequency can not be adjusted.
 1. Connect a voltmeter between the circuit board terminals TP1 (negative) and TP2 (positive).
 2. Run the generator at rated speed and voltage.
 3. Determine the desired underfrequency limit setting voltage from Table 1 for 60 Hz generators or Table 2 for 50 Hz generators.
 4. Adjust R55 until the voltage between TP1-TP2 equals the test voltage given in the appropriate table. EXAMPLE: With unit running at 60 Hz and where limiting is desired at about 55 Hz, the voltage across TP1-TP2 should be -0.438 Vdc.

Manual voltage control variac: This control is included in generators equipped with the automatic/manual voltage control option. During generator operation using the manual voltage control mode, the mode selector is set to MAN and generator voltage output is controlled by the manual voltage control variac. In order to maintain generator output voltage at a constant level during operation in the manual voltage control mode, adjust the manual voltage control variac each time a change in load occurs (either added or shed).

Note: Where the generator will be operating singly and use of reactive voltage droop circuitry is not desired, either set R4 to the minimum droop position or install a jumper or unit/parallel switch across terminals CT• and CT1.

Operational threshold	dc voltage TP1-TP2
60 Hz	0.000
59 Hz	-0.087
58 Hz	-0.169
57 Hz	-0.265
56 Hz	-0.350
55 Hz	-0.438

Table 1: Voltage across under-frequency limit terminals TP1-TP2 with a 60 Hz generator and rated sensing voltage

Note: The jumper wire must be across J1 on a 60 Hz system. Measured voltage must be negative. Slight variation in operating threshold may exist due to circuit and meter tolerances.

Operational threshold	dc voltage TP1-TP2
50 Hz	0.000
49 Hz	-0.107
48 Hz	-0.210
47 Hz	-0.315
46 Hz	-0.425
45 Hz	-0.553

Table 2: Voltage across under-frequency limit terminals TP1-TP2 with a 50 Hz generator and rated sensing voltage

Note: The jumper wire J1 must be removed during 50 Hz operation. Measured voltage must be negative. Slight variation in operating threshold may exist due to circuit and meter tolerances.

Caution: Do not attempt to flash the exciter field while the generator set is running. Be careful to observe polarity when connecting flashing source. Accidental polarity reversal will destroy the voltage regulator power stage.

Caution: Before operating the generator for the first time, double check to make certain all wiring connections are made correctly. Review the wiring diagrams provided with the generator set, the installation instructions above and the preceding adjustment procedures.

Note: Deviation in generator output voltage approximately $\pm 10\%$ of rated can be corrected by adjusting the voltage adjust rheostat and if necessary, the voltage range set adjust.

Field flashing: The voltage regulator contains an internal solid state field flashing circuit. A minimum of about 6 Vac at the regulator input power terminals is required for operation of the flashing circuit. Usually the exciter field poles retain sufficient magnetism to allow circuit operation and generator voltage buildup. However, if flashing is required, stop the generator, and then flash the field as given in the procedure that follows:

1. Connect the negative lead of a 12 or 24 Vdc flashing source onto regulator terminal F-. Do not remove any other wires from terminal F-.
2. Slide the positive lead of the flashing source onto the regulator terminal F+. Only a few seconds flashing should be necessary.
3. Slide the flashing source positive lead off terminal F+. Then remove the flashing source negative lead from terminal F-, and tighten the terminal.
4. Start the generator, and check for satisfactory voltage buildup.

Single unit initial operation: When the generator set is equipped with the automatic/manual voltage control option, normal operation of the generator set is the automatic voltage control mode. During generator set operation in the automatic voltage control mode, generator output voltage is pre-established during no-load operation by adjustment of the external voltage adjust rheostat and automatically maintained at the amplitude under all load conditions from no-load to full rated load by the voltage regulator.

Automatic mode operation: Review the preceding adjustment and single unit operation procedures. The general procedure for single unit automatic mode operation is as given in the procedure that follows:

1. If the generator set is equipped with the auto/manual control option, set the selector switch to AUTO.
2. Turn the voltage adjust rheostat to about one-half of the way between the maximum counterclockwise and maximum clockwise positions.
3. Open the output circuit breaker. Do not apply load until satisfactory no-load operation is attained.
4. If a voltage shutdown switch or field circuit breaker is used, close the switch to connect input power to the voltage regulator.
5. On generators that will be operated parallel and if the sets are equipped with unit/parallel switches, close the switch on all generators.
6. Start the prime mover and bring up to rated speed.
7. Verify generator voltage. Any of the following conditions can occur.
 - No voltage buildup: If this condition exists, the exciter may not have sufficient residual magnetism. Residual magnetism may be restored by flashing the field as described in the "Field Flashing" instructions.
 - Overvoltage (+15% or more): If this condition occurs, open the shutdown switch immediately and/or stop the prime mover. Determine the cause of overvoltage.

- Undervoltage (-15% or more): If this condition occurs, open the shutdown switch immediately and/or shut down the prime mover. Determine the cause of undervoltage.
 - Undervoltage by operation of the underfrequency limit circuit (UFL): Undervoltage by operation of the underfrequency limit circuit can occur if the prime mover governor is not adjusted to maintain rated speed or when the underfrequency limit circuit is adjusted to operate at a frequency that is very close to the rated frequency of the generator.
 - Voltage begins to build up and then collapses: If this condition exists, stop the prime mover and determine the cause of collapse. If necessary refer to troubleshooting procedure.
 - Oscillating voltage (hunting): If this condition occurs, be sure prime mover speed is not fluctuating. Then, if this condition persists, adjust the stability adjust (R6) as given in the stability adjustment section above.
8. Operate the generator set for about 1/2 hour.
 9. After about 1/2 hour of satisfactory operation, close the output circuit breaker and connect the load.
 10. Be sure the generator output voltage is correct and stable. Verify that steady voltage regulation is satisfactory.
 11. Remove the load.
 12. If the generator will be operating parallel, adjust the parallel operation potentiometer R4 as given in the steps that follow. To stop the unit see step 19.
 13. If the generator set is equipped with a unit/parallel switch, open the switch.
 14. Monitor no-load voltage.
 15. Apply inductive load, and note the droop in generator voltage. A droop of about 6% is attained when R4 is turned to complete clockwise position for maximum resistance and the current transformer secondary current is one ampere connected to terminals CT• and CT1 or 5 amperes connected to terminals CT• and CT5.
 16. If droop is more than is required, turn R4 counterclockwise. If droop is less than is required, turn R4 clockwise.
 17. Repeat steps 14 through 16 as necessary to obtain required droop signal.
 18. To stop the unit, remove the load, open the output circuit breaker, and then stop the prime mover.

Manual mode operation: This test applies only to generator sets equipped with the auto/manual voltage control option. Normal operation of the generator set is in the automatic voltage control mode. The manual voltage control mode provides a means of operating the set should the voltage regulator fail. Test the manual control for proper operation during the initial operation of the set and determine whether cause of system malfunctions is due to a faulty generator or a faulty voltage regulator as follows:

1. Perform the preceding automatic mode operating procedure.
2. Open the output circuit breaker and, if it is running, stop the prime mover.
3. If it is included, close the unit/parallel switch.
4. Set the auto/off/manual selector switch to MAN.
5. Set manual voltage adjust variac to the complete counterclockwise position.
6. Start the prime mover, and bring it up to rated speed.
7. Turn the manual voltage adjust variac to the position where the correct generator voltage is measured by the generator voltmeter.
8. Turn the manual voltage adjust variac to the position where voltmeter indicates generator voltage is about 5% higher than rated.
9. Close the output circuit breaker, and apply load.
10. Measure the output voltage. If it is not correct, adjust the manual voltage adjust variac.
11. Repeat steps 8 and 10 each time the load is increased.
12. Before shedding load, decrease generator voltage about 5% below rated.
13. Adjust manual voltage adjust variac to position where the voltmeter indicates generator is producing required voltage.
14. Repeat steps 12 and 13 each time any part of the load is shed.
15. Remove the load and open generator circuit breaker.
16. Set voltage adjust rheostat for rated generator output voltage.
17. Stop the prime mover.
18. Set the auto/off/manual switch to AUTO.

Caution: *In generating systems equipped with the automatic/manual voltage control option, always make parallel operation in the automatic voltage control mode. Never attempt to parallel generators when the mode switch is set to MAN.*

Parallel operation: The paragraphs that follow describe the procedures to operate two or more generators in parallel.

Metering: In order to attain satisfactory paralleling and to check for proper parallel operation all generators should be equipped with the following monitoring equipment:

1. ac voltmeter to measure generator output voltage (one per set)
2. ac voltmeter to measure bus voltage (one per system)
3. ac ammeter (one per set)
4. Power factor or kVAR meter (one per set)
5. kW meter (one per set)
6. Exciter field current dc ammeters (one per set)
7. Synchroscope or a set of lights to indicate when units are in phase

Checks before initial parallel operation: Before initial parallel operation, review the procedures and checks that follow:

1. Verify that each generator is connected to the bus with the same phase rotation as that of the bus. Use a phase rotation test instrument or an induction motor of known rotation during the initial single unit operation procedure.
2. Verify that the voltage regulating system of each generator is equipped with the parallel signal sensing transformer.
3. Make certain the paralleling signal at regulator terminals CT• and CT1 or CT5 have the proper phase rotation with that of the sensing

voltage at terminals E1 and E3. In applications where units are connected for reactive voltage droop, verify that the connection is made as shown in Figure 7. Cross-current compensation application requires interconnection of the system as shown in Figure 8.

4. Prior to operation, set the parallel voltage droop potentiometer R4 on all regulators for identical droop. This can be accomplished by individually testing each generator set, one at a time, as given in the single unit initial operation procedure.

Preliminary parallel operation: Before attempting to parallel two or more generator sets, test individual sets to ensure that paralleling features function properly. The test that follows may be used.

1. On generating systems equipped with the auto/manual control option, verify that the switch is set to AUTO.
2. Verify that the jumper bar has been removed from across the regulator terminals CT• and CT1.
3. On generating systems equipped with unit/parallel switches, verify that the switch on the generator set being tested is set to PAR (open), and be sure that the switch for each remaining generator is set to UNIT (closed).
4. Place the generator in operation as described in the section single unit initial operation.
5. Apply 25% to 100% unity power factor load to the set under test. The generator voltage should change less than 1%, and the frequency should decrease if the governor is set for droop operation.
6. Apply a 25% to 100% 0.8 P.F. inductive load. Voltage should droop. If the voltage rises instead of drooping, reverse the CT leads. If droop is not correct adjust parallel droop resistor R4 as described in the parallel voltage droop resistor adjustment procedure at the beginning of this section.

Paralleling generators: Review and understand these instructions and those contained in preceding paragraphs before attempting to parallel.

1. Set auto/off/manual switch on all generators to AUTO (generator set equipped with automatic/ manual voltage control option).
2. On generating systems equipped with unit/parallel switches, set the switch on unit being started (generator set No. 1) to PARALLEL (open). Set the switch on the remaining generator sets to UNIT (closed).
3. Start generator set No. 1.
4. Adjust the generator voltage and frequency to nominal.
5. Apply the load.
6. Verify satisfactory voltage regulation, and make certain frequency is not fluctuating.
7. Repeat steps 1 and 2 on generator set No. 2.
8. Start generator set No. 2.
9. Adjust generator set No. 2 frequency and voltage to nominal.
10. Adjust the speed of generator set No. 2 slightly higher than that of generator set No. 1.

11. Observing the synchroscope (or lights), when generator No. 2 is in phase with generator No. 1, close the circuit breaker for generator No. 2.
12. Immediately after closing the circuit breaker, measure the line current of generator No. 2. It should be well within the rating of the generator. Also, immediately after closing the circuit breaker, observe the kW or power factor meters. The following conditions could occur:
 - A high ammeter reading accompanied by a large kW unbalance: When this condition exists, the speed governor is either not adjusted correctly or is faulty.
 - A high ammeter reading accompanied by a large kVAR unbalance: When this condition exists, the voltage regulating system is either not adjusted correctly or is faulty.
13. Adjust the speed of generator set No. 2 to the point where each generator is carrying the desired share of kW load.
14. Adjust the voltage of generator No. 2 until the ammeter readings of both generators are near minimum.
15. With full load applied, readjust the speed and voltage of generator No. 2 until the desired load division is obtained.
16. In applications where three or more generators are to be operated parallel, repeat preceding steps 7 through 15 for generator set No. 3, then No. 4, etc.

Note: If kVAR or power factor meters are available, adjust the voltage adjust rheostats for equal or proportional kVAR or power factor readings. If the generators are equipped with power factor meters, alternately adjust the speed and voltage on No. 2 until the ammeter readings are proportional and the power factor readings are equal.

Note: To obtain best results, make final adjustments with full load on the bus.

Note: The best adjustment is obtained when each generator supplies the same percent of its rated current, the power factor readings are equal, or the sum of the ammeter currents is minimum.

Shutting down one or more generators operating in parallel: Before dropping one or more generators operating parallel from the line bus, reduce the total load on the bus to equal to or less than the combined capacity of the generators remaining on the bus. Shut down one or more of generator sets operating parallel as follows:

1. Reduce load to combined capacity of generators remaining on the bus.
2. On systems where the prime mover governor is equipped with a manual speed adjust, shift the load to generators remaining on the bus by reducing the speed of the generator set being dropped from the bus.
3. Close its unit/parallel switch (on generator sets equipped with a unit/parallel switch).
4. Shutdown the prime mover.
5. In applications where three or more generators are operated parallel, repeat preceding steps 1 through 4 for each generator set being taken off the bus.

Maintenance

Preventive maintenance: Inspect the regulator periodically to ensure that air flow is not restricted. Dirt, dust, and other foreign material may be removed using low pressure (25 to 50 PSI) compressed air. Check the connections between the regulator and system periodically to ensure they are tight and free of corrosion.

Corrective maintenance: Make repairs to the regulator by following the figures in this manual. Due to a protective conformal coating, do not attempt repairs on the printed circuit board.

Refer to Table 3 for a list of replacement parts.

On generator sets equipped with the auto/manual voltage control option, operation of the generator set in the automatic voltage control mode can be compared to how well it operates in the manual voltage control mode. Faulty operation in the automatic mode and satisfactory operation in the manual mode indicates a problem in the voltage regulator while, if faulty operation in both the automatic and manual voltage control mode occurs, the problem is probably within the exciter or generator.

Key No.	Description	Part number	Qty
	Circuit board (It is better to replace the entire AVR)	Contact the factory	1
	Terminal strip	531-30311-13	1
	Fuse holder	516-10035-00	1
	Fuse, ABC 15 A	515-01215-31	1
R2	Potentiometer 500 Ω , 25 W, wire wound	867-35075-09	1
R4	Potentiometer 5 Ω , 25 W, wire wound	867-15075-29	1
R6	Potentiometer, 5000 Ω , 25 W, wire wound	867-45075-79	1
T1, T3	Transformer (sensing)	855-63619-02	1
L1	Filter choke	859-61010-00	1
T2	Cross-current transformer	855-11610-02	1
	Power block 600 V, 25 A	851-33620-70	1
VAR	External voltage adjust potentiometer, 250 Ω	867-32522-80	1

Table 3: Replacement parts list

Voltage regulator operational test: Use the following test procedure to determine if the regulator is basically operational:

1. Connect regulator as shown in Figure 12.
2. Connect internal wire from terminal E3 to the tap on the sensing transformer T1 that matches the input power described in step 6.
3. Connect jumper across terminals CT• and CT1.
4. Adjust the external voltage adjust for maximum resistance (complete counterclockwise position). If the light is on when voltage adjust is turned to its complete counterclockwise position, the problem is likely in the regulator.
5. Connect light bulb across terminals F+ and F- and wires to terminals E1, E3, P1, and P2 as shown in Figure 12.
6. Connect to 120 Vac power source when regulator full load output rating is 65 Vdc. Connect to 240 Vac power source when regulator full load output rating is 125 Vdc.
7. Turn the external voltage adjust clockwise. Before reaching the maximum clockwise position, the bulb should come on to near full brilliance.
8. At the regulating point a small change in adjustment of the external voltage adjust rheostat should turn the light on or off. If the light does not come on, the problem is likely in the regulator.
9. Before installing back in the generating system, connect the regulator as it was before steps 2 through 7.

Note: *Incorrect electrical connections between the generator system and the regulator and poor electrical connections are often the cause of system malfunction. Before assuming a failure of the generator or regulator has occurred, check wiring against the wiring diagrams provided with the generator set and the instructions given above. Also make certain all connections are tight and free of corrosion.*

Troubleshooting: Between regular preventive maintenance inspections, be alert for any signs of trouble. Correct any trouble immediately. See Table 4 for typical symptoms, causes, and remedies.

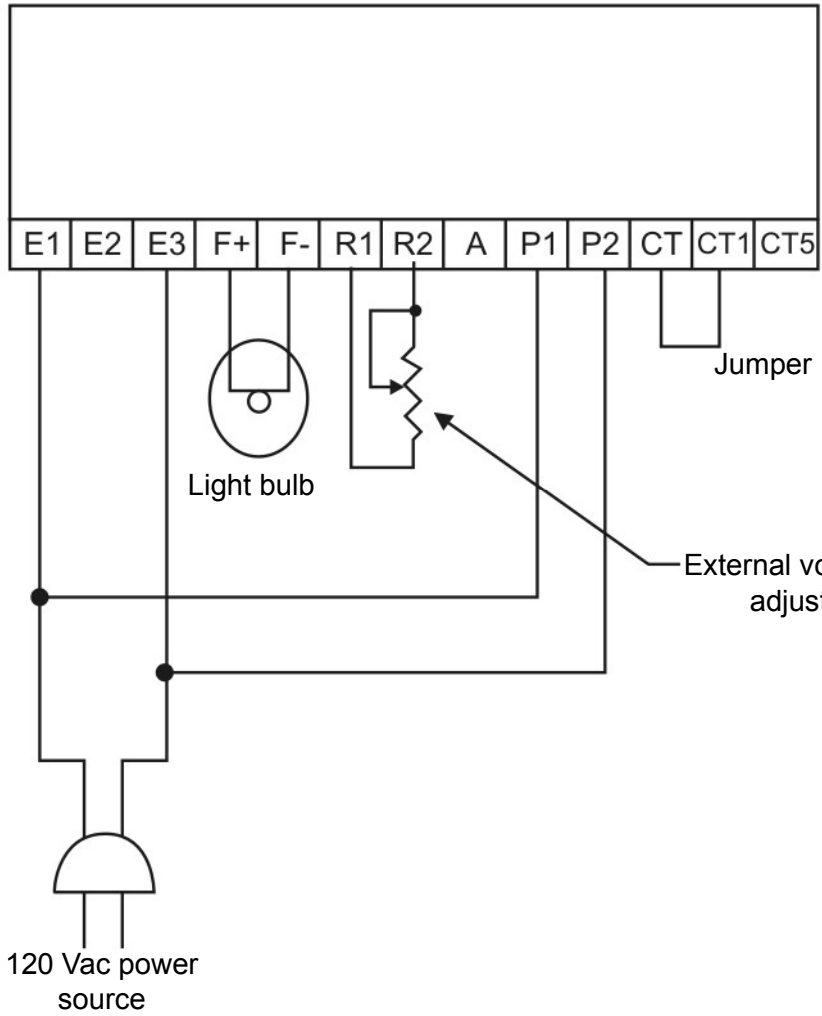

Note: The internal wire from E3 must connect to the 120 Vac tap on transformer T1.

Note: 120 Vac may be used to test voltage regulators designed for 120 Vac or 240 Vac input power.

Figure 12: KCR 760 operational test

Symptom	Cause	Remedy
Voltage does not build up to rated value	Shutdown switch is open	Close the switch.
	Fuse is blown	Replace the fuse. If the fuse blows repeatedly, determine the cause of the overload.
	Auto/off/manual switch is on OFF	Set to the switch to AUTO.
	Field circuit breaker is open	Close the circuit breaker.
	No input power to terminals P1 and P2	Verify wiring.
	Inaccurate generator voltmeter	Verify using a test voltmeter. Calibrate or replace a faulty meter.
	Voltage too low at terminals P1 and P2	Verify wiring.
	Low residual voltage (or reverse residual)	Flash the field per the procedure.
	Internal wire from the sensing terminals on the regulator is not connected to the correct tap on the sensing transformer(s)	Verify wiring.
	No connection or poor connection between the exciter field and the regulator terminals F+ and F-	Correct the wiring, and check the connections.
	Prime mover not up to rated speed	Bring the prime mover up to rated speed.
	Open or incorrectly connected external voltage adjust rheostat	Verify wiring.
	Voltage range adjust R2 is set too low	Refer to the setting procedure.
	Potentiometer R89 out of adjustment	The adjustment is factory set. If it is accidentally adjusted during operation, contact Kato Engineering.
	Faulty regulator power stage	Test. If it is faulty, replace the voltage regulator or power module.
	Faulty printed circuit board	Replace the voltage regulator.
	Voltage builds up until flashing circuitry operates and then oscillates between approximately 1/3 to 2/3 rated voltage	Defective rectifiers in the exciter, defective exciter windings, or defective generator
Generator output heavily loaded		Remove excessive load.
Faulty printed circuit board		Replace voltage regulator.
Voltage is high and not controllable with the voltage adjust rheostat	No voltage to sensing terminals on the regulator	Verify wiring.

Voltage is high and not controllable with the voltage adjust rheostat (cont.)	Open sensing transformer	Verify wiring, and check for open windings.
	Automatic/off/manual switch set to MAN	Set to Auto for automatic voltage regulation.
	External voltage adjust rheostat shorted	Verify wiring. Use an ohmmeter to test resistance across the rheostat. Replace shorted rheostat.
	Internal wire from sensing terminals on the regulator is not connected to the correct tap on the sensing transformer(s)	Verify the nominal sensing voltage from the generator and wiring to the sensing transformers.
	Faulty regulator circuit board	Replace the voltage regulator.
	Faulty regulator power stage SCRs or diodes	Replace the power module or the voltage regulator.
Voltage high, controllable with voltage adjust rheostat	Internal wire from terminals) E2 and E3 to the wrong tap on the sensing transformer(s) T1 and T3	Verify the nominal generator voltage. Correct the wiring.
	Improper connection of the sensing to the regulator sensing terminals	Verify wiring to the voltage regulator.
	Single-phase sensing applied to a regulator designed for three-phase sensing	Connect three-phase sensing.
	Voltage range adjust R2 set too high	Adjust R2 per the procedure.
	R89 adjustment is off	Factory set. If accidentally turned, contact Kato Engineering.
	Generator voltmeter is inaccurate	Connect a test voltmeter to check operation of the generator output. Calibrate or replace the meter.
	Faulty regulator power stage	Replace the voltage regulator or power module.
	Faulty regulator circuit board	Replace the voltage regulator.
Poor regulation	Voltage at regulator terminals P1 and P2 are too low at the nominal generator voltage	Input voltage for standard KCR 760 voltage regulators is 100 to 139 Vac for a unit with 65 Vdc output and 200 to 240 Vac for a unit with 125 Vdc output.
	Jumper not installed across terminals CT• and CT1 while the generator is operating singly	Install a jumper.
	Unit/parallel switch in PARALLEL during single generator operation	Switch to UNIT.
	Unit/parallel switch of the generator not on the bus set to PAR position	Set the switch of the generators not on the bus to UNIT.
	The prime mover is not up to rated speed, or the prime mover speed is fluctuating	Bring the prime mover up to rated speed and/or adjust the governor.
	Unbalanced load	Balance the load.
	Exciter field resistance is too low and /or the exciter field volts are too low	Add a series resistor. Resistance must not be less than 6.5 Ω for a 65 Vdc continuous full-load rated regulator or 12.5 Ω for a 125 Vdc regulator. The voltage applied to the exciter field at no load must not be less than 10 Vdc. Best operation occurs when the voltage is about 20 Vdc during no-load operation. The resistor must not limit regulator output during full load operation.

Poor regulation (cont.)	Faulty regulator circuit board	Replace the circuit board.
	Faulty regulator power stage diodes or SCRs	Replace the voltage regulator or power module.
Poor voltage stability	Stability adjust R6 not adjusted to provide sufficient stabilizing signal.	Adjust R6 per the procedure.
	Frequency unstable.	Adjust the prime mover or the governor.
	No-load field voltage and/or resistance is too low	Add a series resistor. Resistance must not be less than 6.5 Ω for a 65 Vdc continuous full-load rated regulator or 12.5 Ω for a 125 Vdc regulator. The voltage applied to the exciter field at no load must not be less than 10 Vdc. Best operation occurs when the voltage is about 20 Vdc during no-load operation. The resistor must not limit regulator output during full-load operation.
	Voltage at regulator input power terminals P1 and P2 is too low	Input voltage for standard KCR 760 voltage regulators is 100 to 139 Vac for a unit with 65 Vdc output and 200 to 240 Vac for a unit with 125 Vdc output.
	Voltage fluctuated to a point where flashing circuit energizes or de-energizes	Replace the circuit board or the voltage regulator.
	Fault in the exciter or generator	Verify the exciter and generator operation.
Voltage recovery slow on load change	Stability adjust R6 maladjusted	Adjust R6 per procedure.
	Slow prime mover response	Check the speed governor operation, and adjust as necessary.
	Exciter field resistance too high	Refer to the specifications given. Resistance must not limit regulator output.
	Voltage regulator capacity is less than exciter requirements	Refer to the regulator specifications.
	Generator and/or prime mover are overloaded	Reduce load to rated.
Underfrequency limit (UFL) operates at too high or too low of a frequency	Prime mover needs adjustment.	Verify governor operation, and adjust as required.
	Incorrect use of 50/60 or 400 Hz selector J1	Correct the use of jumper J1 per procedure.
	Wrong voltage regulator	Contact Kato Engineering.
	UFL threshold adjust (R55) not adjusted correctly	Adjust R55 per procedure.
No droop compensation can be obtained for parallel generators	Jumper across terminals CT• and CT1	Remove the jumper.

No droop compensation can be obtained for parallel generators (cont.)	Unit/parallel switch closed (set to UNIT)	Set the switch on the generator sets to PAR. Leave the switch on UNIT on any generators that will remain shutdown.
	Parallel droop adjust R4 set to minimum droop	Turn R4 clockwise to increase droop.
	Parallel CT does not supply the correct secondary current	When a 1 A CT is used, connect to the regulator terminals CT• and CT1. Terminals CT• and CT5 are for use with a 5 A CT. Determine rated line current and voltage, and consult the factory. Verify the number of turns on the generator line through transformer are correct.
Voltage rises instead of droops on application of inductive load	Wrong polarity between the parallel CT secondary leads and the regulator terminals	Interchange leads at terminals CT• and CT1. Where a 5 A CT is used, terminals will be CT• and CT5.
Parallel generators do not divide reactive kVAR load equally resulting in circulating reactive current between generators	Terminals CT• and CT1 or CT5 shorted by jumper or unit/parallel switch	Remove the jumper. Set the unit/parallel switch to PAR.
	Unequal adjustment of voltage droop potentiometers	Adjust for equal droop
	Droop potentiometers on generators operating parallel are set at different droop positions	Adjust R4 on all generators for identical droop per the procedure.
	Wrong parallel CT or wrong ampere turns through the CT primary	Consult Kato Engineering.
	Parallel CT is not in the correct generator line	Verify the wiring.
	Parallel CT polarity is reversed	Interchange the CT secondary leads at the regulators terminals. CT• and CT1 are for use with a 1 A CT. CT• and CT5 are for use with a 5 A CT.
Parallel generators do not evenly divide kW load	Improper setting of the governor power sensing	Adjust the governor.

Table 3: Troubleshooting

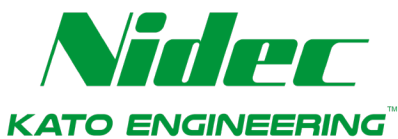

Kato Engineering Support

The brand you trust, the power you depend on. Include the serial number and model number for your machine in the email subject line.

Field Service

KatoService@mail.nidec.com

Parts

KatoParts@mail.nidec.com

Remanufacturing

KatoRemanufacturing@mail.nidec.com

Warranty/Quality Assurance

KatoWarranty@mail.nidec.com

Kato Engineering, Inc. | P.O. Box 8447 | Mankato, MN USA 56002-8447 | Tel: 507-625-4011
KatoEngineering@mail.nidec.com | www.KatoEngineering.com | Fax: 507-345-2798