

6 TROUS Ø9 SUR Ø200,02 EQUIDISTANT
6 HOLES Ø9 ON Ø200,02 EQUID.

Ø 361,95 ± 0,127

8 TROUS Ø11 SUR Ø381
8 HOLES Ø11 ON Ø381

(c)

TYPE	Xg	Masse Kg Weight	J Kgm ²
LSA40 S3 / LL & LLD III4H	204	87	0.0936
LSA40 S4 / LL & LLB III4L	221	92	0.1004

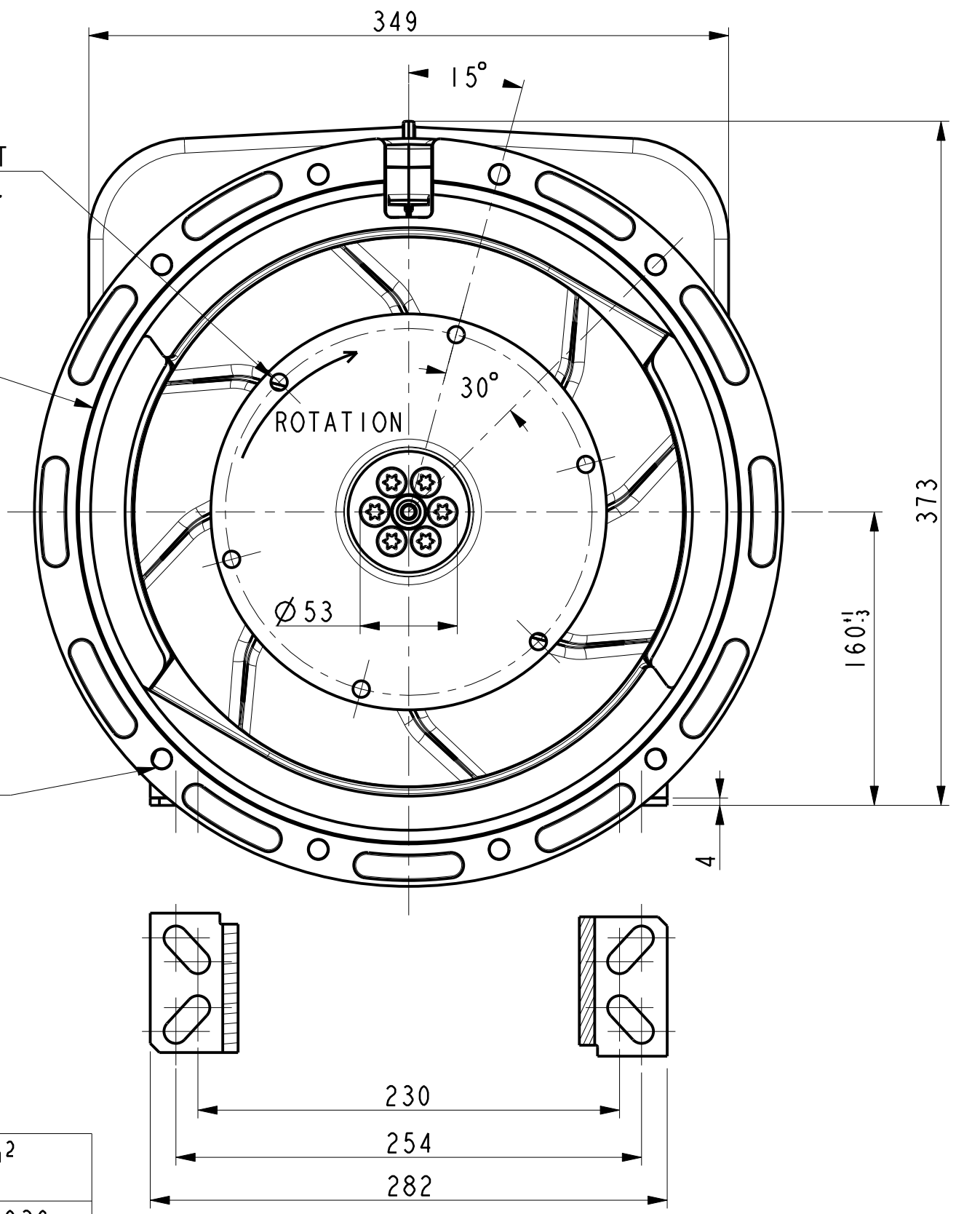

Pre perçage Ø17 Ø21 Ø25 Ø32 Ø37
Pre-drilling

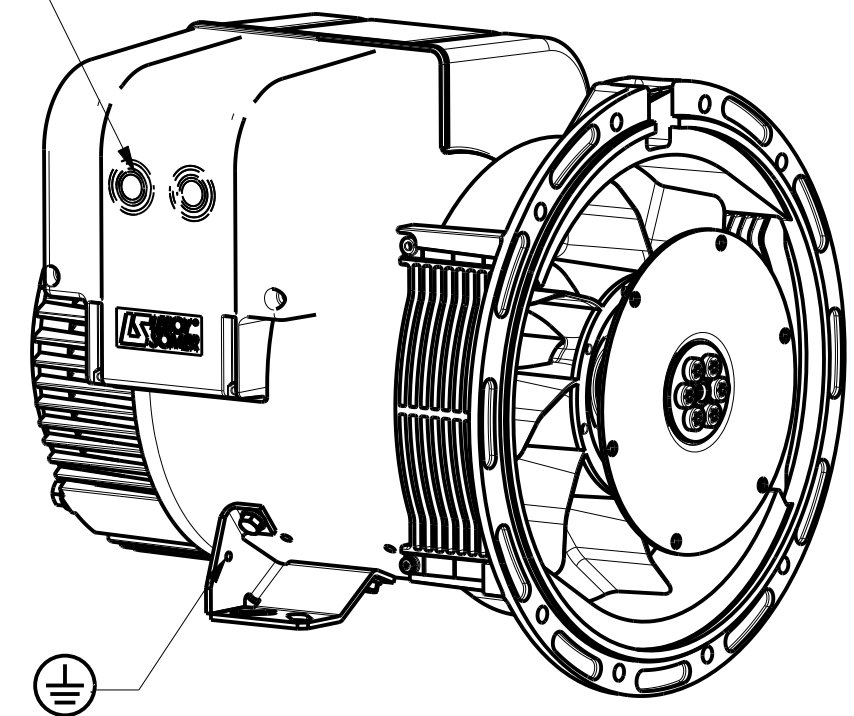

ECHELLE 0,200

Sortie des cables Gauche vue bout d'arbre en STD
Acces regulateur Droite vue bout d'arbre en STD
Output power on left hand side view DE standard
Access to regulator on right hand side view DE standard

-	-	-	-	-	-	-
C	16/09/15	Nombre de trous SAE, 12 devient 8	15-561	HAMPL	-	-
b	30-09-2009	Mise à jour cotation	09-372	G.Rabel	-	-
a	X	X	-	X	X	X
INDICE	DATE	NATURE DE LA MODIFICATION	N° C.T.	NOM	VERIF B.E.	VERIF METH
Tolerances generales:			Etats de surfaces (NFE 05-016) Ra: - partout sauf indications			
Ref: -			Echelle Machine: ALTERNATEUR ALTERNATOR			
Obs: SAE 4 - 6 1/2			0,333 LSA40			
Matiere:			Designation: ENCOMBREMENT			
Modele de base: -			OUTLINE			
Variante: -						
Composant: -			LEROY SOMER MOTEURS LEROY-SOMER			
Compose: -			16015 ANGOULEME - FRANCE			
Dessine: Broussard		Verif methodes				
Verifie: -						
Date: 21/04/09						
				A2		LSA40-8-002