

TYPE	Xg	Masse Kg Weight	J Kgm ²
LSA40 L7 / LL & LLD 1114N	236	114	0,1538

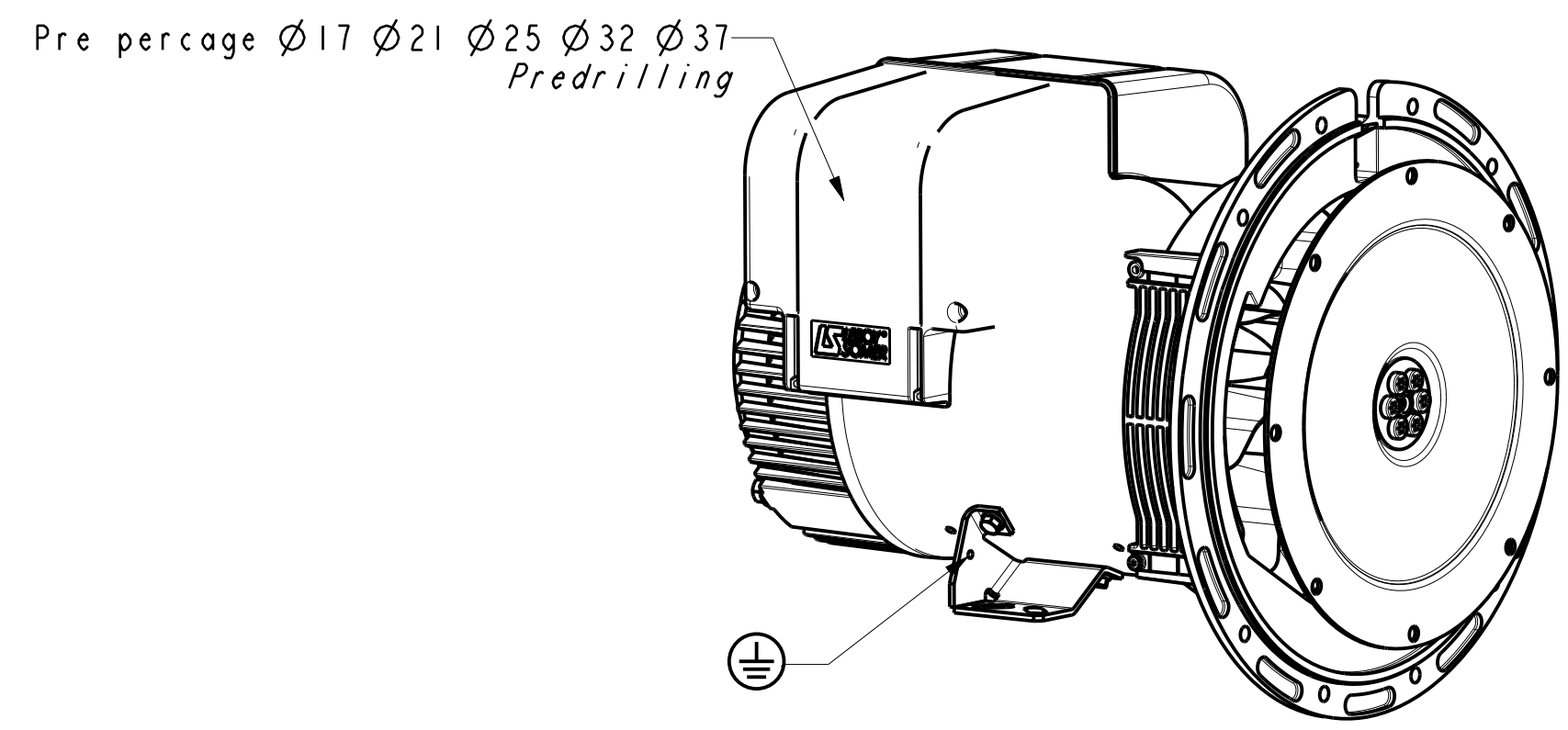

Sortie des cables Gauche vue bout d'arbre en STD
 Acces regulateur Droite vue bout d'arbre en STD
*Output power on left hand side view DE standard
 Access to regulator on right hand side view DE standard*

-	-	-	-	-	-	-
b	10/09/2015	Nombre de trous SAE, 12 devient 8	15-544	Truksa	-	-
a	07-10-2009	Création	09-372	G.Rabel	X	X
INDICE	DATE	NATURE DE LA MODIFICATION	N° C.T.	NOM	VERIF B.E.	VERIF METH
Tolerances generales:			Etats de surfaces (NFE 05-016) Ra: - partout sauf indications			
Ref: -			Echelle Machine: ALTERNATEUR ALTERNATOR			
Obs: SAE 3 - 11 1/2 - STANDARD			0,333 LSA40			
Matiere:			Designation: ENCOMBREMENT			
Modele de base: -			OUTLINE			
Variante: -			MOTEURS LEROY-SOMER 16015 ANGOULEME - FRANCE			
Composant: -						
Compose: -						
Dessine: G.Rabel		Verif methodes				
Verifie: P.V						
Date: 07-10-2009				A2		B
				LSA40-8-017		