

8 TROUS Ø11 SUR Ø295,28 EQUIDISTANT  
8 HOLES Ø11 ON Ø295,28 EQUID.

8 TROUS Ø11 SUR Ø381  
8 HOLES Ø11 ON Ø381  
(b)

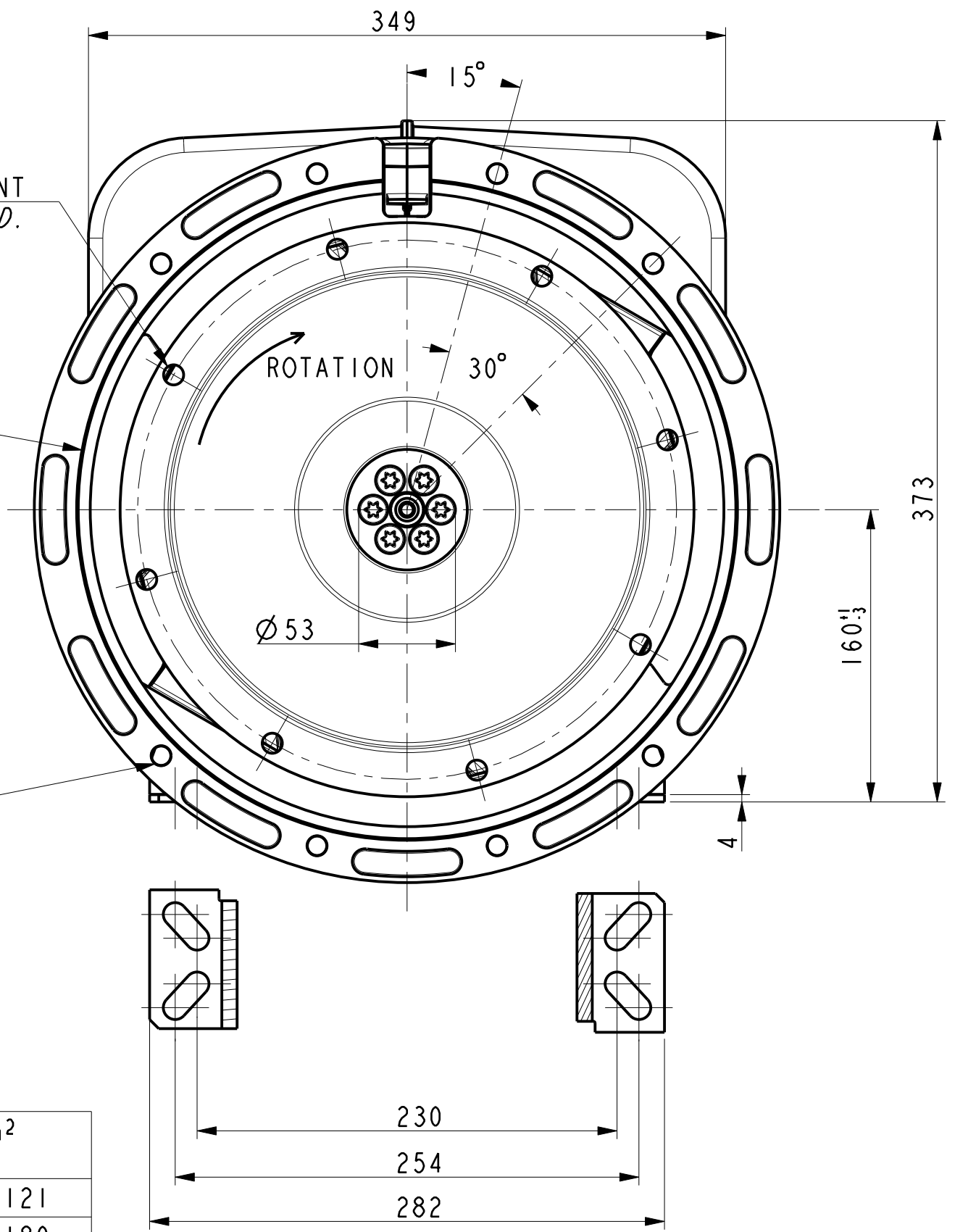

TYPE	Xg	Masse Kg Weight	J Kgm <sup>2</sup>
LSA40 S3 / LL & LLD III4H	204	88	0.1121
LSA40 S4 / LL & LLB III4L	221	93	0.1189

Pre perçage Ø17 Ø21 Ø25 Ø32 Ø37  
Predrilling

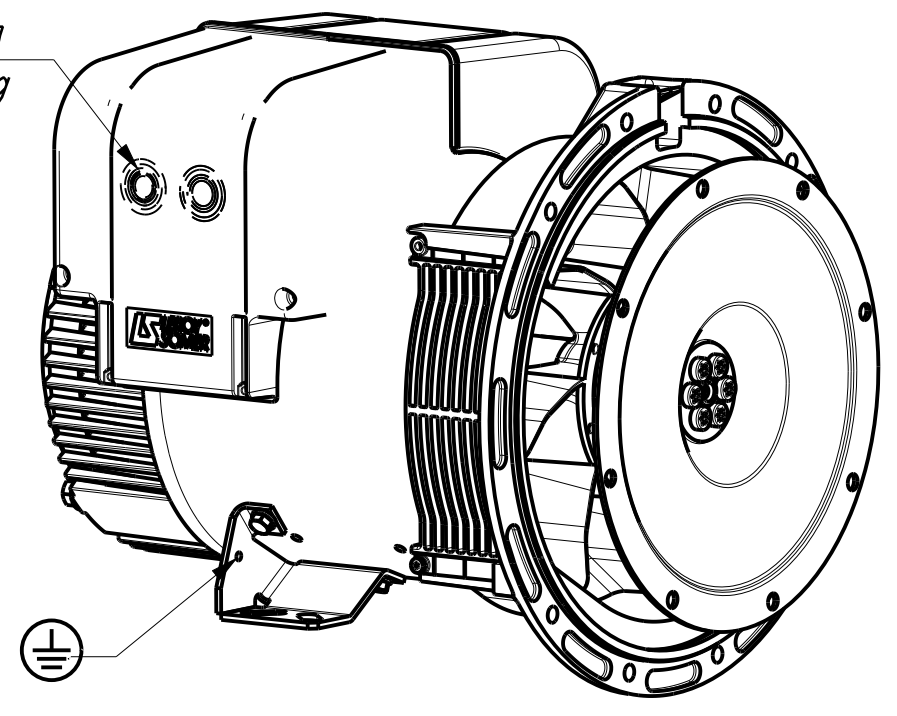

ECHELLE 0,200

Sortie des cables Gauche vue bout d'arbre en STD  
Acces regulateur Droite vue bout d'arbre en STD  
Output power on left hand side view DE standard  
Access to regulator on right hand side view DE standard

-	-	-	-	-	-	-
b	24/09/15	Nombre de trous SAE, 12 devient 8	15-584	HAMPL	-	-
a	18-11-2009	Création	09-372	G.Rabel	X	X
INDICE	DATE	NATURE DE LA MODIFICATION	N° C.T.	NOM	VERIF B.E.	VERIF METH
Tolerances generales:			Etats de surfaces (NFE 05-016) Ra: - partout sauf indications			
Ref: -			Echelle Machine: ALTERNATEUR ALTERNATOR			
Obs: SAE 4 - 10			0,333 LSA40			
Matiere:			Designation: ENCOMBREMENT			
Modele de base: -			OUTLINE			
Variante: -			<b>LEROY-SOMER</b> MOTEURS LEROY-SOMER 16015 ANGOULEME - FRANCE			
Composant: -						
Compose: -						
Dessine: G.Rabel		Verif methodes				
Verifie: -						
Date: 18-11-2009						
			<b>A2</b>		<b>LSA40-8-036</b>	