

6 trous Ø11 sur Ø244,48
6 holes Ø11 on Ø244,48

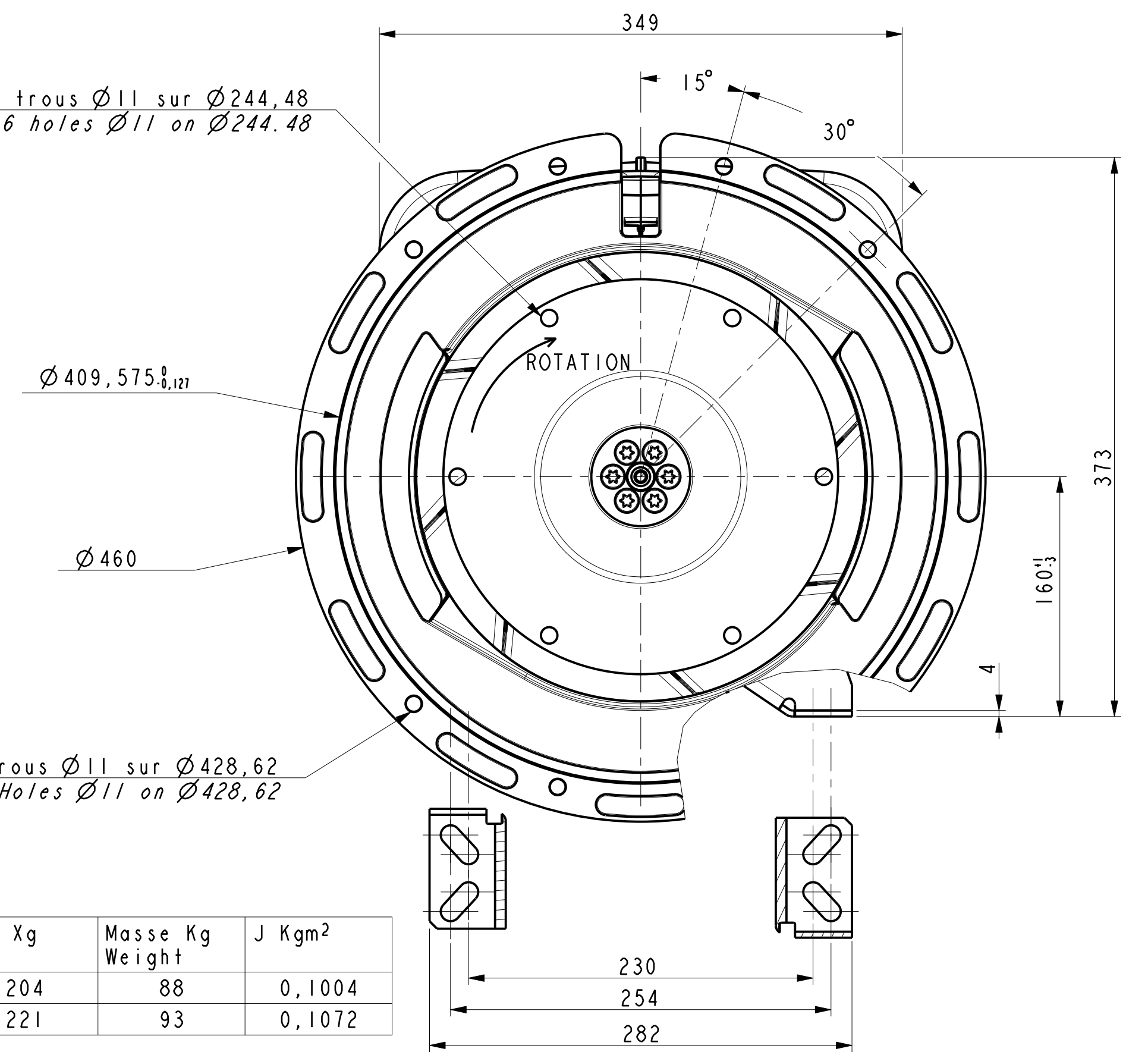

(b)
8 Trous Ø11 sur Ø428,62
8 Holes Ø11 on Ø428,62

TYPE	Xg	Masse Kg Weight	J Kg ²
LSA40 S3 / LL & LLD IIII4H	204	88	0,1004
LSA40 S4 / LL & LLB IIII4L	221	93	0,1072

Pre perçage Ø17 Ø21 Ø25 Ø32 Ø37
Predrilling

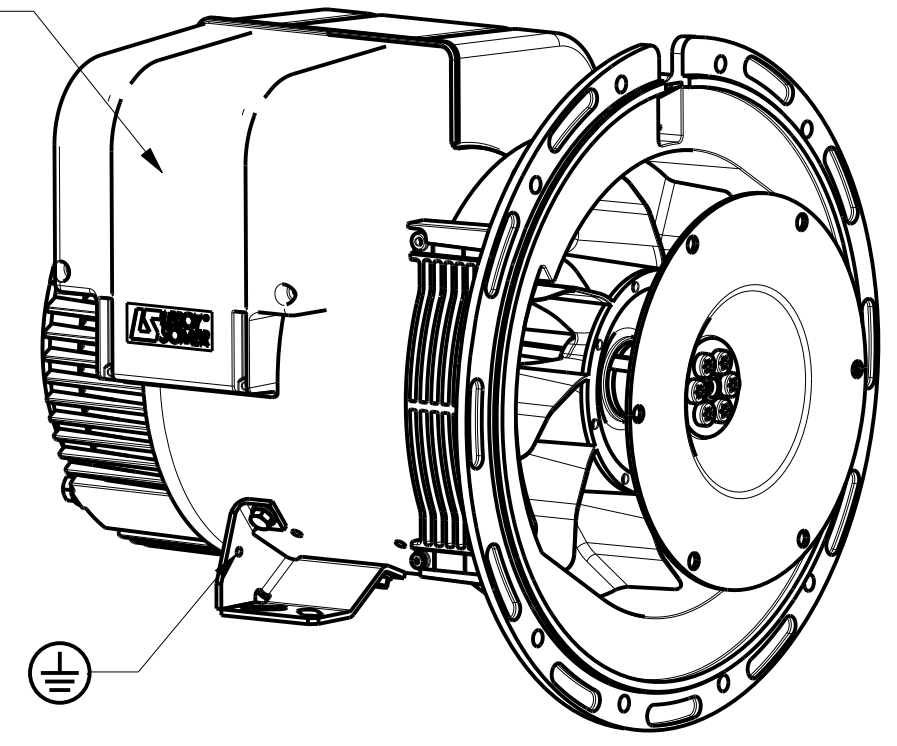

ECHELLE 0,200

Sortie des cables Gauche vue bout d'arbre en STD
Acces regulateur Droite vue bout d'arbre en STD
Output power on left hand side view DE standard
Access to regulator on right hand side view DE standard

-	-	-	-	-	-	-
b	11/09/2015	Nombre de trous SAE, 12 devient 8	15-544	Truksa	-	-
a	18-11-2009	Création	09-372	G.Rabel	X	X
INDICE	DATE	NATURE DE LA MODIFICATION	N° C.T.	NOM	VERIF B.E.	VERIF METH
Tolerances generales:			Etats de surfaces (NFE 05-016) Ra: - partout sauf indications			
Ref: -			Echelle Machine: ALTERNATEUR ALTERNATOR			
Obs: SAE 3 - 8			0,333 LSA40			
Matiere:			Designation: ENCOMBREMENT			
Modele de base: -			OUTLINE			
Variante: -			MOTEURS LEROY-SOMER 16015 ANGOULEME - FRANCE			
Composant: -						
Compose: -						
Dessine: G.Rabel		Verif methodes				
Verifie: P.V						
Date: 18-11-2009				A2		B
				LSA40-8-040		