

8 Trous Ø11 sur Ø295.28
8 Holes Ø11 on Ø295.28

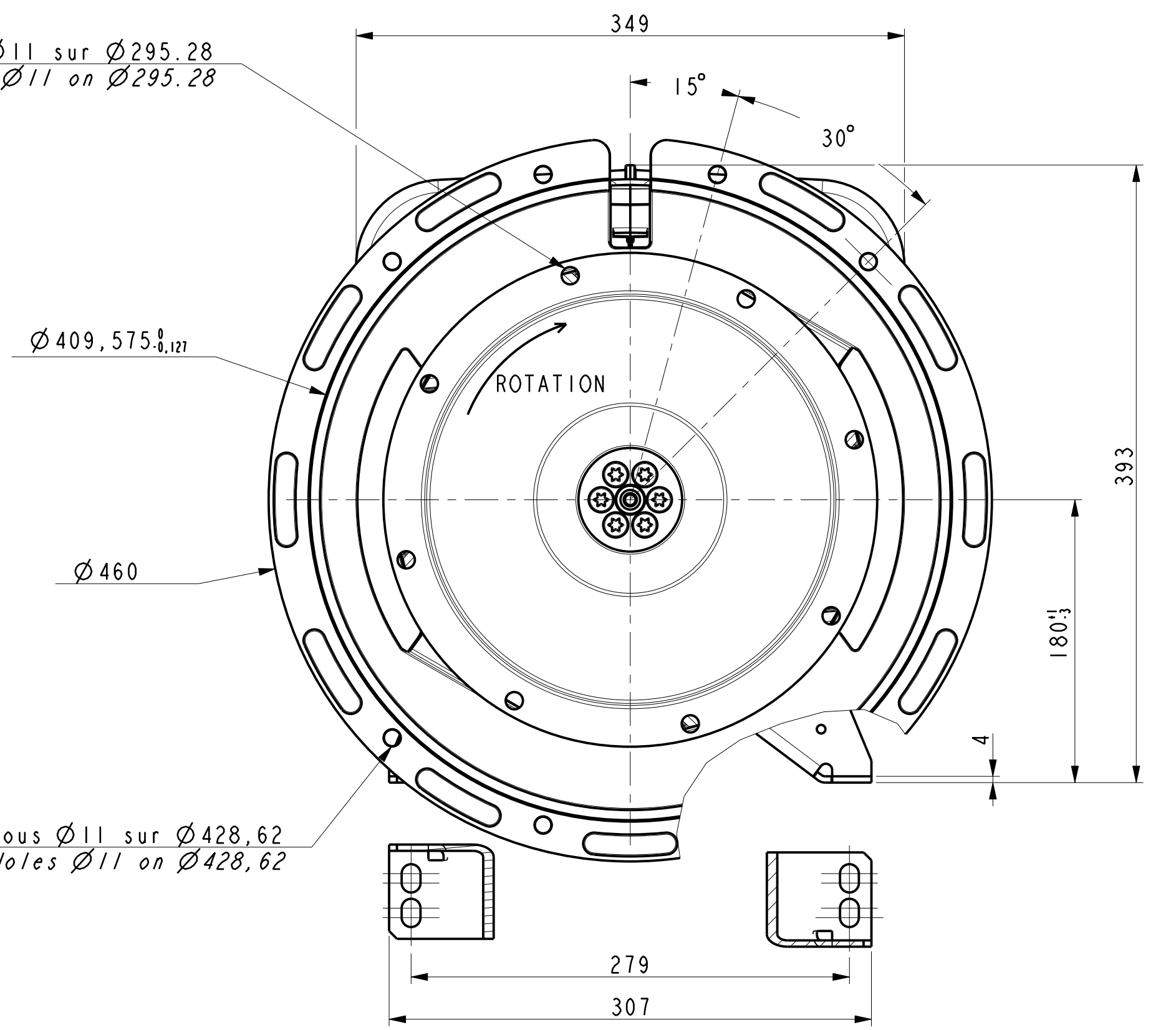

(b)
8 Trous Ø11 sur Ø428,62
8 Holes Ø11 on Ø428,62

TYPE	Xg	Masse Kg Weight	J Kg ²
LSA40 VSI / LL & LLD III4D	186	75	0,0964
LSA40 VS2 / LL & LLB III4F	196	82	0,1052

Pre perçage Ø17 Ø21 Ø25 Ø32 Ø37
Predrilling

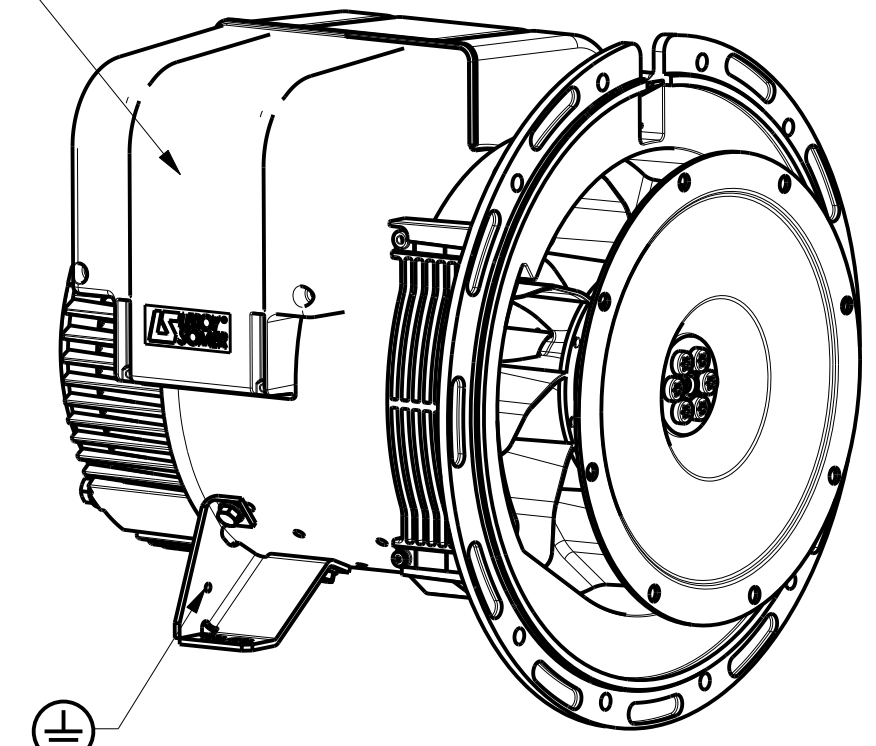

ECHELLE 0,200

Sortie des cables Gauche vue bout d'arbre en STD
Acces regulateur Droite vue bout d'arbre en STD
Output power on left hand side view DE standard
Access to regulator on right hand side view DE standard

-	-	-	-	-	-	-
-	-	-	-	-	-	-
b	10/09/2015	Nombre de trous SAE, 12 devient 8	15-535	Truksa	-	-
a	18-11-2009	Création	09-372	G.Rabel	X	X
INDICE	DATE	NATURE DE LA MODIFICATION	N° C.T.	NOM	VERIF B.E.	VERIF METH
Tolerances generales:			Etats de surfaces (NFE 05-016) Ra: - partout sauf indications			
Ref: -			Echelle Machine: ALTERNATEUR ALTERNATOR			
Obs: SAE 3 - 10 + H=180mm			0,333 LSA40			
Matiere:			Designation: ENCOMBREMENT			
Modele de base: -			OUTLINE			
Variante: -			MOTEURS LEROY-SOMER 16015 ANGOULEME - FRANCE			
Composant: -						
Compose: -						
Dessine: G.Rabel		Verif methodes				
Verifie: P.V						
Date: 18-11-2009						
				A2		LSA40-8-047