

TYPE	Xg	Masse Kg Weight	J Kg ²
LSA40 M5 / LL & LLD IIII4M	221	100	0.1102

Pre perçage $\phi 17$ $\phi 21$ $\phi 25$ $\phi 32$ $\phi 37$
 Predrilling

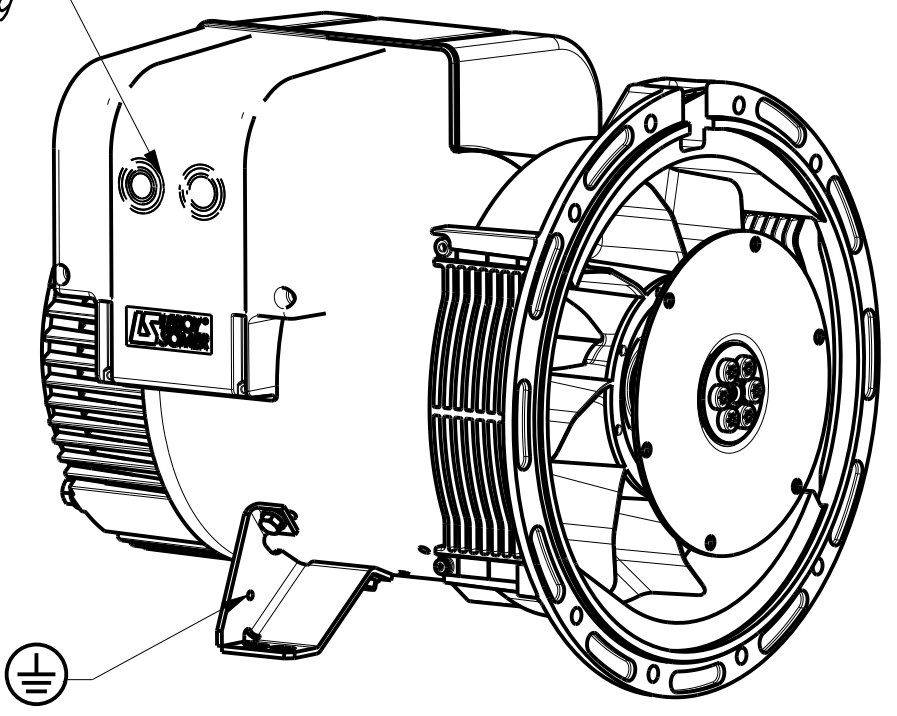

ECHELLE 0,200

Sortie des cables Gauche vue bout d'arbre en STD
 Acces regulateur Droite vue bout d'arbre en STD
 Output power on left hand side view DE standard
 Access to regulator on right hand side view DE standard

-	-	-	-	-	-	-
-	-	-	-	-	-	-
b	15/09/15	Nombre de trous SAE, 12 devient 8	15-561	HAMPL	-	-
a	20-11-2009	Création	09-372	G.Rabel	X	X
INDICE	DATE	NATURE DE LA MODIFICATION	N° C.T.	NOM	VERIF B.E.	VERIF METH
Tolerances generales:			Etats de surfaces (NFE 05-016) Ra: - partout sauf indications			
Ref: -			Echelle Machine: ALTERNATEUR ALTERNATOR			
Obs: SAE 4 - 6 1/2 + H=180mm			0,333 LSA40			
Matiere:			Designation: ENCOMBREMENT			
Modele de base: -			OUTLINE			
Variante: -			LEROY-SOMER MOTEURS LEROY-SOMER 16015 ANGOULEME - FRANCE			
Composant: -						
Compose: -						
Dessine: G.Rabel		Verif methodes				
Verifie: -						
Date: 20-11-2009						
			A2		LSA40-8-065	