

Sortie des cables Gauche vue bout d'arbre en STD
Acces regulateur Droite vue bout d'arbre en STD
Output power on left hand side view DE standard
Access to regulator on right hand side view DE standard

Pre percage $\varnothing 21 \varnothing 25 \varnothing 32 \varnothing 40 \varnothing 50$
Predrilling

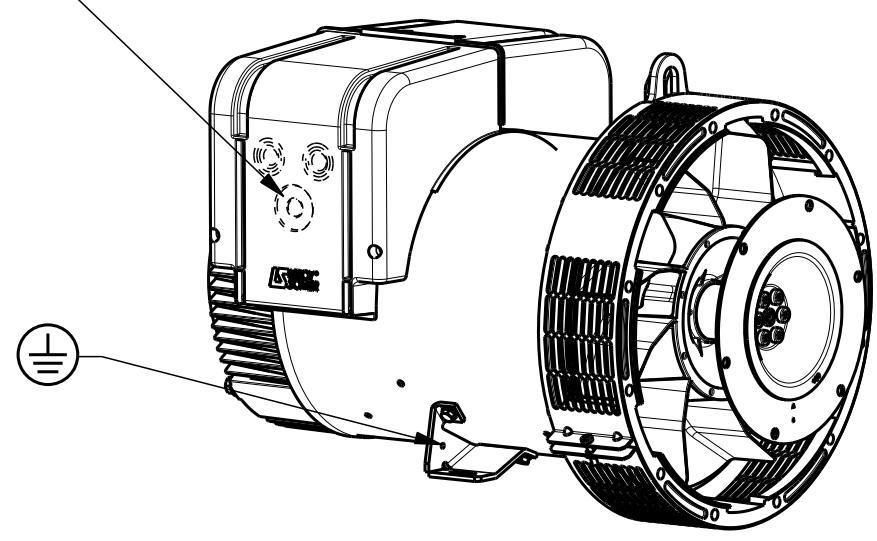

ECHELLE 0,125

Acces regulateur
Access to regulator

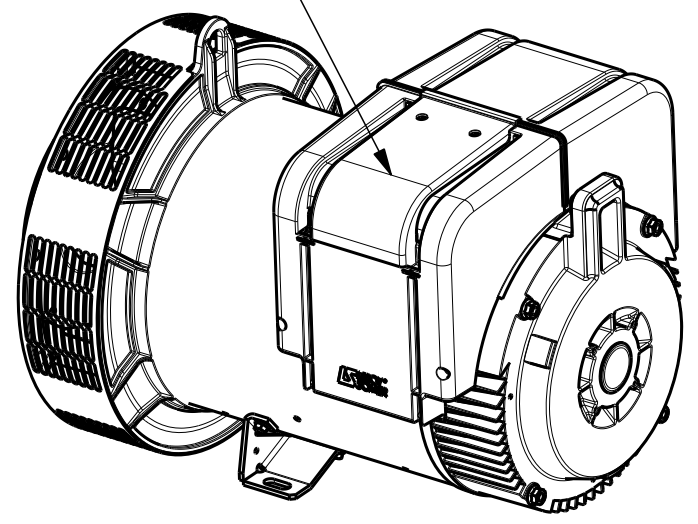

ECHELLE 0,125

e	14/03/2013	Modification dimension	13-179	Veselský		
d	14/12/2011	cote 618 ==> 618	11-586	JMD	AR	SM
c	10/10/2011	Ajout tolérances sur $\varnothing 409.58$	11-453	JMD	AR	SM
b	19/09/2011	Turbine 11 pales ==> 8 pales	11-412	JMD	AR	SM
a	X	X	11-346	X	X	X
INDICE	DATE	NATURE DE LA MODIFICATION	N° C.T.	NOM	VERIF B.E.	VERIF METH
Tolerances generales: - generale			Etats de surfaces (NFE 05-016) Ra: - partout sauf indications			
Ref: -			Echelle Machine: ALTERNATEUR ALTERNATOR			
Obs: SAE 3 - 8 H=180 - L9			0,250 LSA423			
Matiere:			Designation: ENCOMBREMENT			
Modele de base: -			OUTLINE			
Variante: -			MOTEURS LEROY-SOMER 16015 ANGOULEME - FRANCE			
Composant: -						
Compose: -						
Dessine: Debord		Verif methodes				
Verifie: AR		S MAROT				
Date: 25/07/11		25/07/2011				
			A2		LSA423-8-062	