

12 trous $\varnothing 12$ équidistants sur $\varnothing 530.22$
 12 holes $\varnothing 12$ equidistant on $\varnothing 530.22$

8 trous $\varnothing 14$ équidistants sur $\varnothing 438.15$
 8 holes $\varnothing 14$ equidistant on $\varnothing 438.15$

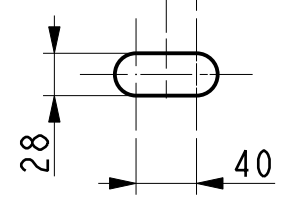
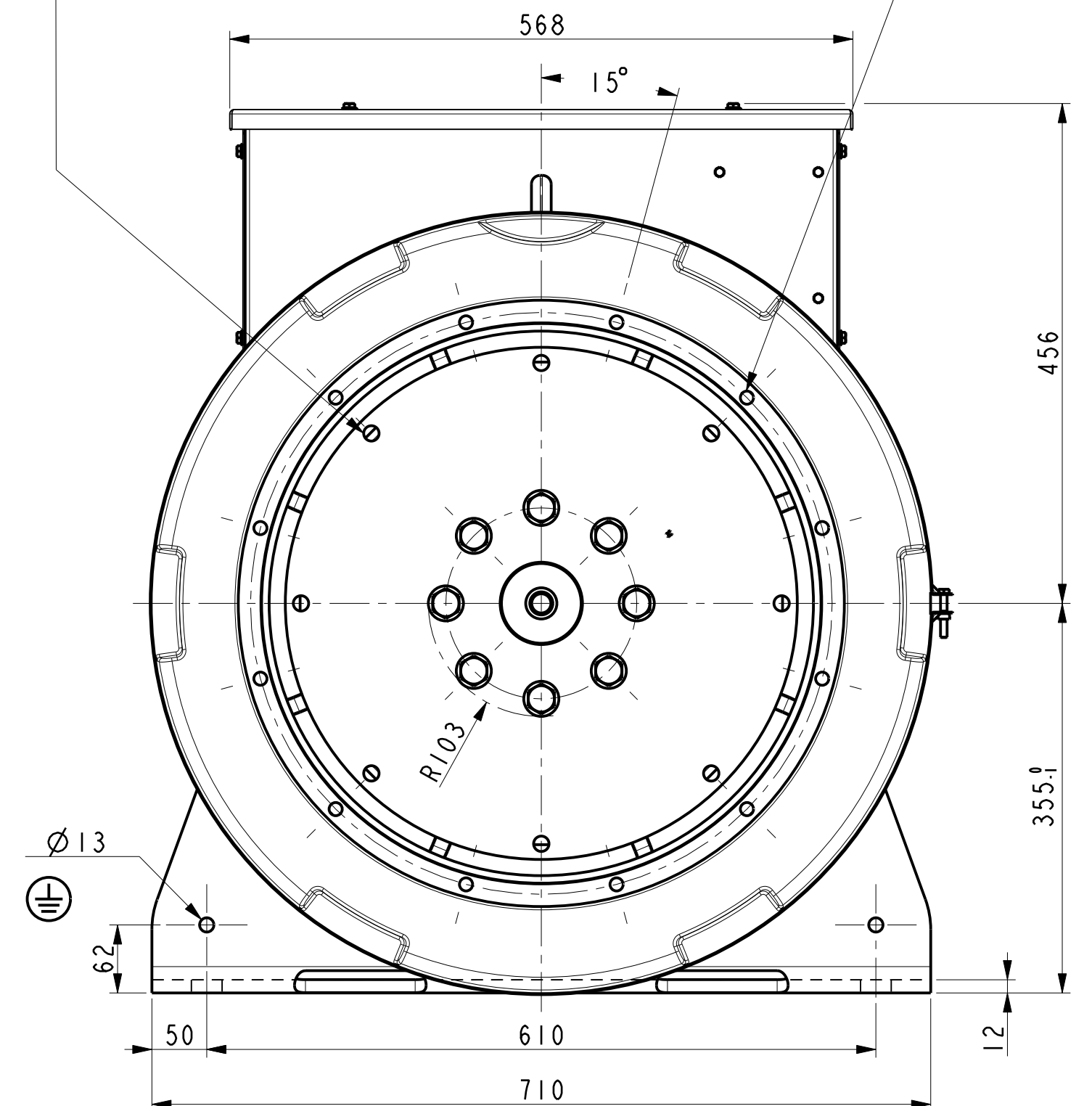

ACCES AUX DIODES
 ACCESS TO RECTIFIERS

-	-	-	-	-	-	-
-	-	-	-	-	-	-
b	27/01/2016	Mise à jour sangle arrière	15-854	PRIKRYL	-	-
a	X	X	15-771	X	X	X
INDICE	DATE	NATURE DE LA MODIFICATION	N° C.T.	NOM	VERIF B.E.	VERIF METH
Tolerances generales:			Etats de surfaces (NFE 05-016) Ra: partout sauf indications			
Ref: -			Echelle Machine: ALTERNATEUR ALTERNATOR			
Obs: -			0,200 TAL 047			
Matiere:			Designation: ENCOMBREMENT TAL D-E SAE 1-14			
Modele de base:			OUTLINE			
Variante:						
Composant:			LEROY SOMER MOTEURS LEROY-SOMER 16015 ANGOULEME - FRANCE			
Compose:						
Dessine: PRIKRYL		Verif methodes				
Verifie:						
Date: 15/12/2015				A2 TAL047-8-007		B